

# SPECIFICATIONS

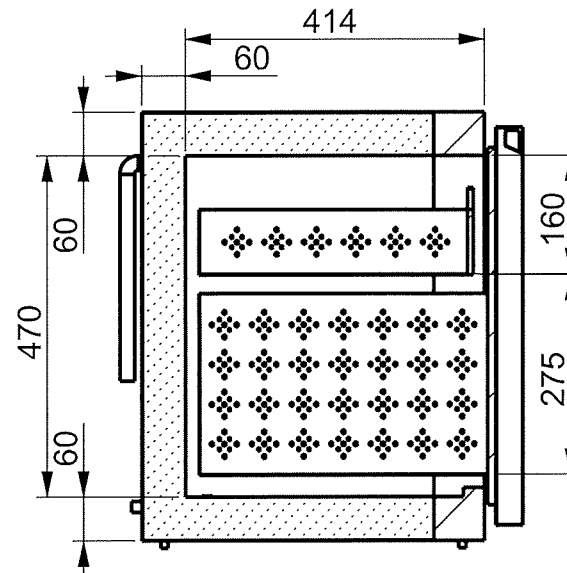
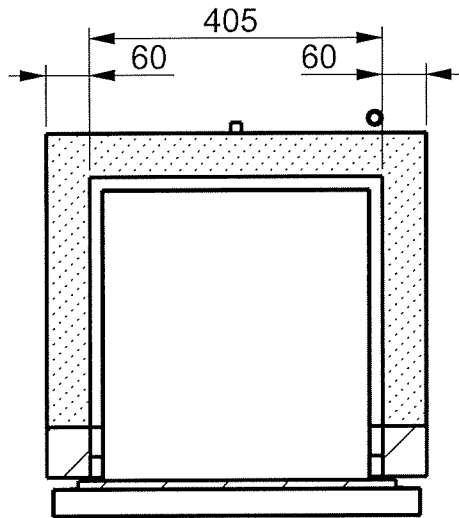
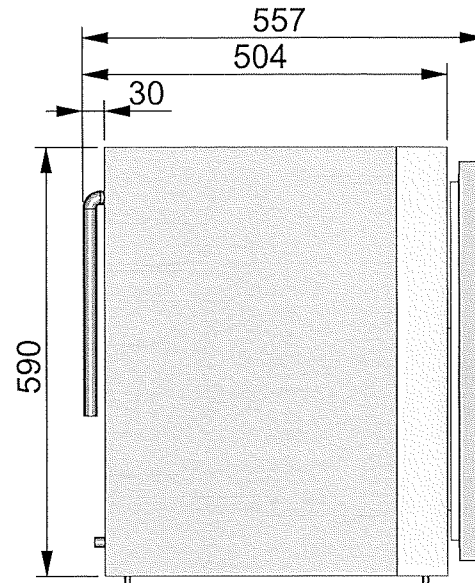
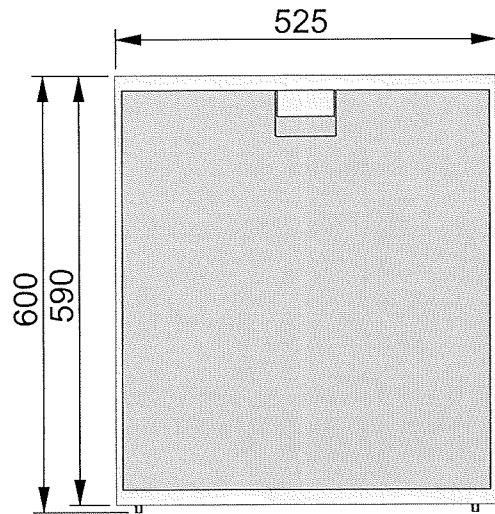

## FEATURES CABINET CC1

- W525xD557xH590 capacity of the freezer 75Lt;
- Range of temperature from -10°C to -20°C;
- External plasticized galvanized metal sheet;
- Internal walls in polished stainless steel 304BA;
- External front and door in stainless steel 316SB;
- Polyurethane foam insulation thickness 60mm;
- Condensate drainage connected by ¼ coupling;
- Internal dimension drawer 01: L360 x D380 x H160
- Internal dimension drawer 02: L360 x D400 x H275
- Integrated copper tube evaporator;
- Gas expansion by capillary pipe;
- Mechanical thermostat for temperature control;
- External compressor (pipe length 2,5m);
- Do not place the refrigerator directly to atmospheric agents, but cover it with proper protections.

CODICE PRODOTTO / PRODUCT CODE	REVISIONE / REVISION:
mod. CC1	R02
	DATA / DATE:
	04/04/2018



Via Confin 64, 30020 Torre di Mosto (Venezia) Italia Tel: +39 0421.325214 - Fax: +39 0421.325343  
 E-Mail: info@frigonautica.it - P.IVA: 03687150270  
 www.frigonautica.it

PROPRIETA' DI FRIGONAUTICA srl  
 Senza autorizzazione scritta della stessa il presente disegno non potrà essere utilizzato per la costruzione dell'oggetto rappresentato, né venire comunicato a terzi o riprodotto anche parzialmente. La società proprietaria tutela i propri diritti a rigor di legge.  
 ALL PROPRIETARY RIGHT RESERVED BY FRIGONAUTICA srl  
 This drawing shall not be reproduced also partially or in any way utilized for the manufacture of the component or unit herein illustrated and must not be released to other parties without written consent. Any infringement will be legally pursued.