



SpecSeal® 1000EX Intumescent Wrap Strip

SpecSeal® 1000EX Wrap Strips are highly flexible, elastomeric strips designed to firestop combustible penetrations in fire-rated floors, floor/ceilings, and walls.

These products utilize STI's fast responding intumescent technology, providing very responsive and highly directionalized expansion. Rapid expansion provides quick closure for burning combustible penetrants.

When exposed to temperatures in excess of 250°F (121°C), the SpecSeal® Wrap Strip begins to expand (intumesce) rapidly to form a dense, highly insulative char. Free expansion varies according to the grade utilized (See Table A). Expansion continues up to temperatures of 1,000°F (538°C).

Applications

SpecSeal® Wrap Strips are used for firestopping combustible penetrants such as nonmetallic pipes or pipe insulation. Installations were developed for restraining collar assemblies (for surface mounting). For larger openings or complex penetrant configurations, systems were developed utilizing wrap strips in conjunction with other SpecSeal® products. SpecSeal® Wrap Strips are suitable for use in all common forms of construction including concrete floors, concrete walls, concrete block walls, and concrete block walls.

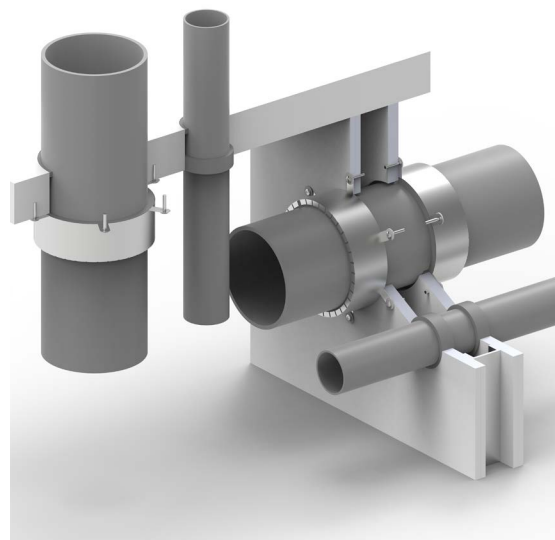

Specifications

The wrap strip material shall be a highly flexible, intumescent material. The wrap strip shall contain no water soluble expansion ingredients and provide a minimum of 30x free expansion. The intumescent wrap strip shall be faced on each side with plastic. The specified material shall be approved for a wide range of applications including combustible and noncombustible penetrants when used by itself or in combination with other products from the same manufacturer. The wrap strip shall be UL Certified and tested to the requirements of and CAN/ULC-S115.

Specified Divisions

Division 7	07 84 13	Penetration Firestopping
Division 22	22 00 00	Firestopping for Plumbing

Features & Benefits

- Rapid expansion - closes off burning penetrants faster
- High volume char - significant expansion seals off opening
- Water-resistant - no soluble or hygroscopic ingredients
- Highly flexible - no foil, easier to install
- Versatile - performer for a wide range of complex applications

Performance

SpecSeal® Wrap Strips are the basis for systems that meet the exacting criteria of and CAN/ULC-S115. Systems were tested for all common forms of construction and penetrants with ratings up to 4 hours (dependent upon grade of wrap strip utilized).



Limitations

This product has been designed to be safe with plastics. It has been used extensively and successfully with various types of plastic pipes, tubes, and plastic cable insulations. Variations in these materials, however, make it impossible to guarantee compatibility. STI strongly recommends that the user consults with the pipe, tubing, or cable manufacturer in question regarding any known sensitivities or potential restrictions before applying this product.

Maintenance

Inspection: Installations should be inspected periodically for subsequent damage. Any damage should be repaired using SpecSeal® products per the original approved design.

SpecSeal® 1000EX Intumescent Wrap Strip



System Selection

To find your firestop system or create a submittal, visit <https://systems.stifirestop.com/> to use System Search & Submittal Builder. You may also visit the [UL Online Certifications Directory/UL Product iQ™](#) for complete listings. (Firestop Systems).

Technical Service

Specified Technologies Inc. provides toll free technical support to assist in product selection and appropriate installation design. UL System designs suitable for submittal or specification purposes are available on request. A complete library of technical information is provided at the company's website www.stifirestop.com including Safety Data Sheets (SDS's).

Precautionary Information

Consult Safety Data Sheet (SDS) for additional information on the safe handling and disposal of this material. Wash areas of skin contact with soap and water. Avoid contact with eyes.

Availability

SpecSeal® Wrap Strips are available from Specified Technologies Inc. (STI) authorized distributors. For additional purchasing and technical information or for the names and locations of the nearest representative and/or distributor, regarding this and other Specified Technology products, please call 1-800-992-1180 or visit www.stifirestop.com.

TABLE A: PHYSICAL PROPERTIES	
Catalog Number	SSW1000EX
Color	Black
Thickness	3/16" (4.8 mm)
Width	2" (51 mm)
Length (min.)	30' (9.1 m)
Weight (min.)	4.275 lbs (1.93 kg)
Expansion System	Single-Stage
Expansion Begins	320°F (160°C)
Volume Expansion	30x to 60x
Mold & Fungus Growth Rating (ASTM G21)	0
In Service Temperature	Less than 130°F (54°C)
Storage Temperature	Less than 130°F (54°C)
Shelf Life	No Limit
Oven Aging	No Change 140°F (60°C)
Humidity Exposure	No Change 60°C (98% R.H.)
UL Accelerating Aging	Pass

SSW1000EX WRAP AND RESTRAINING COLLAR REQUIREMENTS

Trade Size (in.)	Pipe OD (in.)	1st Layer (in.)	2nd Layer (in.)	3rd Layer (in.)	Total Length (in.)	Collar Length (in.)
1.5	1.9	6.8	-	-	6.8	7.9
2.0	2.375	8.3	-	-	8.3	9.5
2.5	2.875	9.9	10.7	-	20.6	11.9
3.0	3.5	11.8	12.6	-	24.3	13.9
3.5	4	13.4	14.1	14.9	42.4	16.3

ORDERING INFORMATION

Catalog Number	UPC Number	Size	(UOM) Qty.	Case Qty.	Weight (Each)
SSW1000EX	730573950425	2" Wide x 3/16" Thick x 30ft Long	1	4	4.275 lbs (1.93 kg)
SSWRC	730573037508	2" (50.8 mm) width 30 Gauge sheet metal restraining collar for ≤4" (102 mm) trade size pipe, 25' (7.6 m) roll	1	1	6.47 lbs (2.93 kg)
WSC-8	730573037539	4" (101.6 mm)width preformed restraining collar for 6" (152 mm) and 8" (204 mm) trade size pipe	1	1	1.51 lbs (0.68 kg)
WSC-12	730573037607	5" (127 mm) width preformed restraining collar for 8" (204 mm) trade size pipe and larger	1	1	3.15 lbs (1.43 kg)

IMPORTANT NOTICE: ALL STATEMENTS, TECHNICAL INFORMATION, AND RECOMMENDATIONS CONTAINED HEREIN ARE BASED UPON TESTING BELIEVED TO BE RELIABLE, BUT THE ACCURACY AND COMPLETENESS THEREOF IS NOT GUARANTEED. STI TYPICALLY WARRANTS ITS PRODUCTS FOR ONE FULL YEAR. FOR COMPLETE DETAILS OF OUR STANDARD WARRANTY, PLEASE VISIT WWW.STIFIRESTOP.COM/LEGAL/WARRANTY. MADE IN THE USA - © 2021 SPECIFIED TECHNOLOGIES INC.

