



**Model: 122172-18**

**SPECIAL FEATURES**

- 1500+ hours life (Infinity Brush)
- 700 Peak Air Watts
- Up to 45% Overall Efficiency
- High efficient cooling system
- Lamb "Green Power Label"
- UL recognized, Category PRGY2 (E47185) and XEWR2 (E27701)
- CSA certification pending under Class 1611-30
- Same mounting pattern as Lamb's 7.2 tangential-bypass
- With locked-rotor, blocked cooling air and running overload protection
- With new patent-pending bearing protection for wet applications.

**DESCRIPTION**

- Single stage tapered fan
- 8.4" / 213mm diameter
- Improved sound quality
- "True" tangential discharge bracket
- 240 volts AC
- 3.5" High-Efficiency lamination
- Double ball bearings; 10mm output

**DESIGN APPLICATION**

- Commercial and Residential Central Cleaning Systems
- Car wash vac and blower systems
- Equipment operating in environments requiring separation of working air from motor ventilating air
- Designed to handle clean, dry, filtered air only

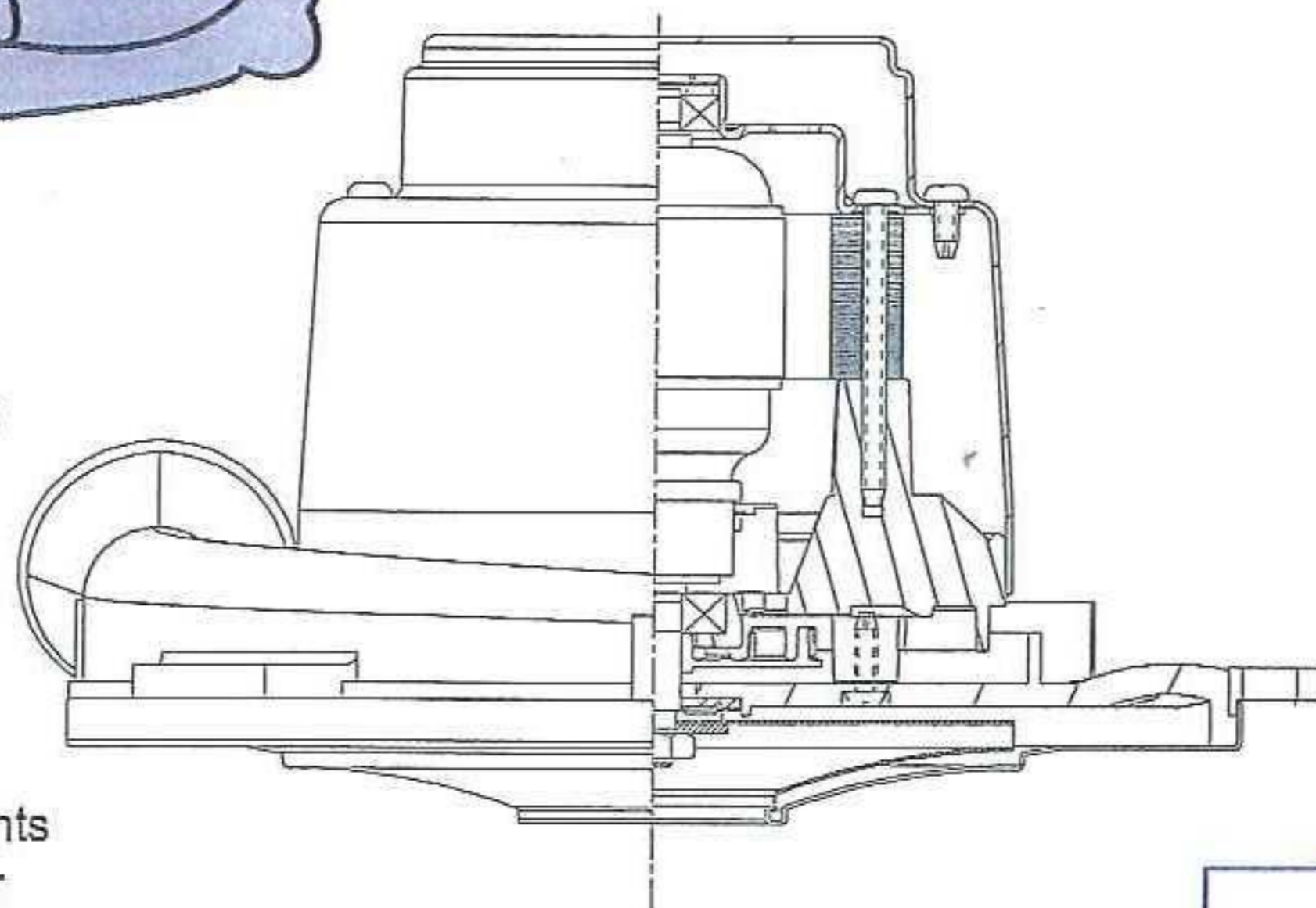

**PEAK AIRWATTS**

**706**

Calculated in accordance with ASTM F2105

**TYPICAL MOTOR PERFORMANCE.\***

(At 240 volts, 60Hz, test data is corrected to standard conditions of 29.92 Hg, 68° F.)

**ASTM DATA**

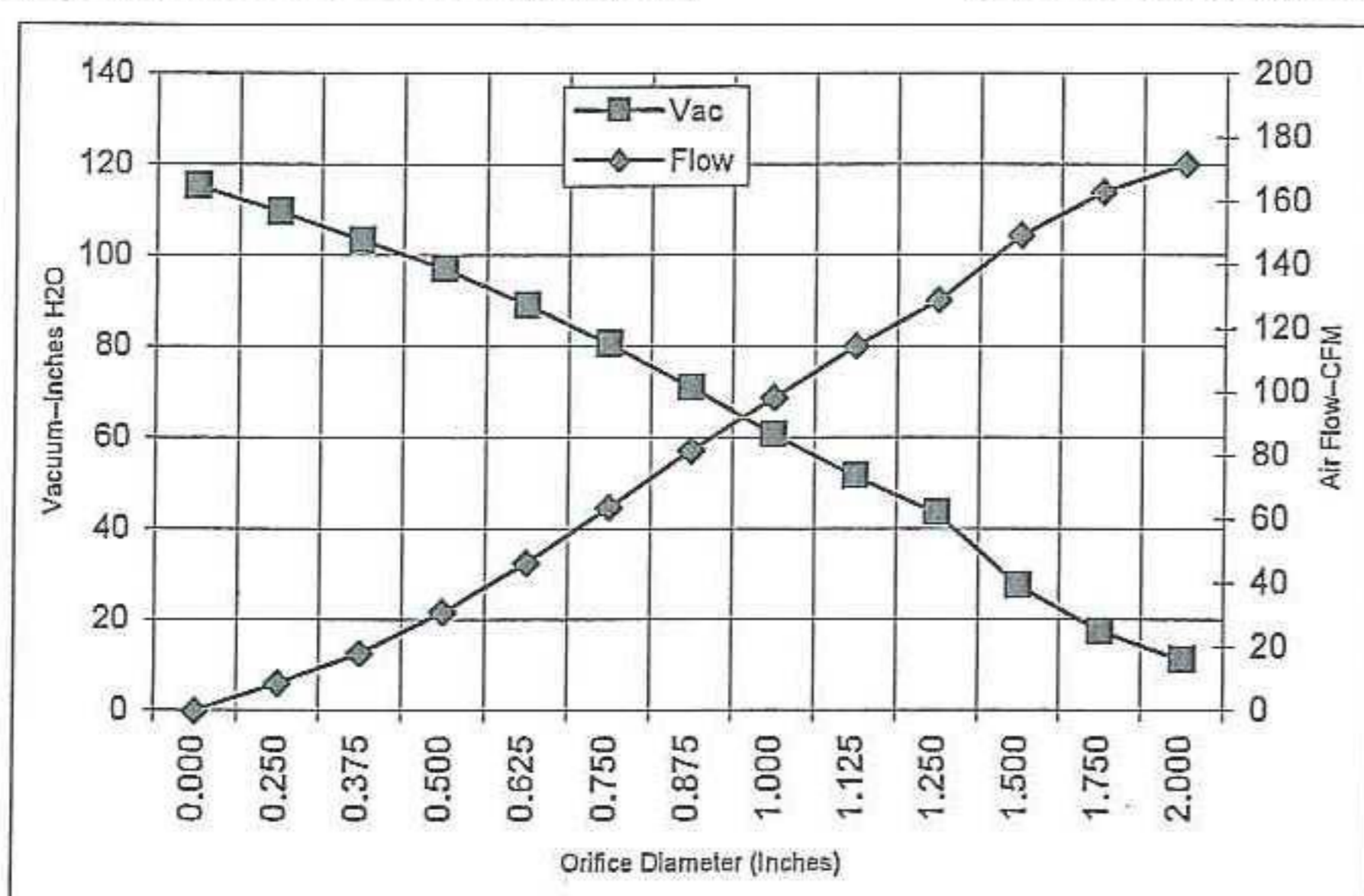

Orifice (Inches)	Amps	Watts (In)	RPM	Vac (In.H2O)	Flow (CFM)	Air Watts
2.000	7.8	1759	26910	11.2	171.7	225
1.750	7.8	1751	26910	17.3	162.9	332
1.500	7.8	1754	26910	27.5	149.4	483
1.250	7.7	1724	26910	43.4	128.9	642
1.125	7.5	1689	27300	51.4	114.7	693
1.000	7.2	1633	27690	60.6	98.3	701
0.875	8.9	1569	28080	71.0	81.7	682
0.750	6.5	1481	28880	80.7	63.8	605
0.625	6.0	1370	30070	89.1	46.4	487
0.500	5.3	1213	21260	97.1	31.0	354
0.375	4.8	1115	24450	103.4	18.0	219
0.250	4.5	1049	33640	109.7	8.6	110
0.000	4.5	973	34830	115.3	0.0	0

**METRIC DATA**

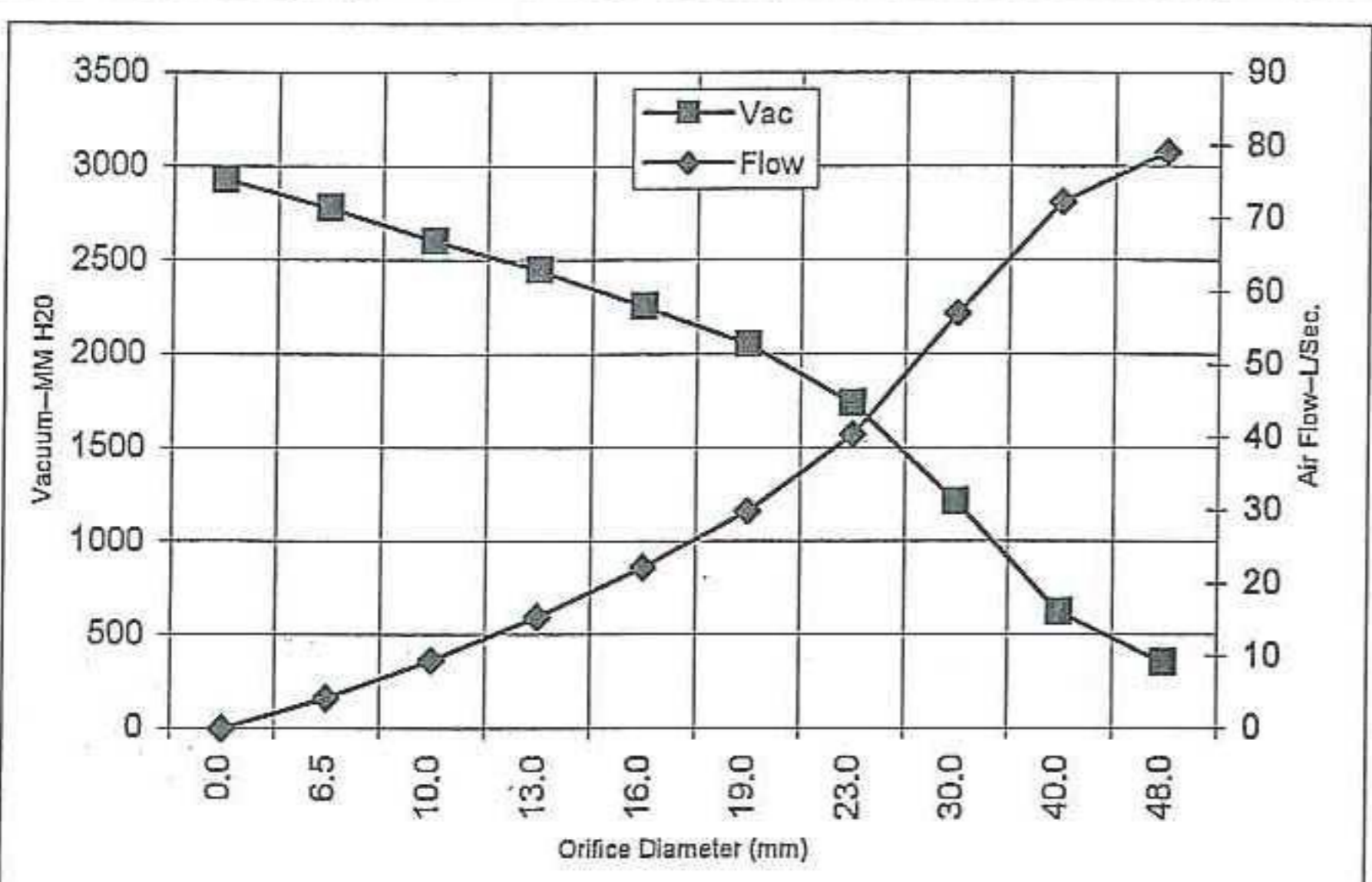

Orifice (mm)	Amps	Watts (In)	RPM	Vac (mm H2O)	Flow (L/Sec)	Air Watts
48.0	7.8	1755	26910	352	79.2	272
40.0	7.8	1753	26910	621	72.4	438
30.0	7.6	1705	27125	1214	57.1	670
23.0	8.5	1585	27983	1737	40.5	686
19.0	6.5	1479	28904	2053	29.9	603
16.0	6.0	1374	30022	2254	22.2	491
13.0	5.4	1229	22141	2446	15.3	367
10.0	4.9	1130	23972	2601	9.4	239
6.5	4.5	1052	33181	2779	4.3	116
0.0	4.5	973	34830	2928	0.0	0

Note: Metric Performance data is calculated from the ASTM data above.

\* Data represents performance of a typical motor sampled from a large production quantity. Individual motor data may vary due to normal manufacturing variations.

Test Specs:	240	Minimum Sealed Vacuum:	100"	ORIFICE:	7/8"	Minimum Vacuum:	65"	Maximum Watts:	1750
-------------	-----	------------------------	------	----------	------	-----------------	-----	----------------	------

DIMENSIONS



NOTES:

1. LEADS: 16GA, STRANDED.
2. MOTOR IDENTIFICATION: MANUFACTURER'S NAME, MODEL NUMBER, VOLTAGE, FREQUENCY, INSPECTOR'S CODE WITH "FF" SUFFIX, THERMALLY PROTECTED L, DATE OF MANUFACTURE, AGENCY RECOGNITION CODE, PLANT LOCATION CODE, PATENT PENDING AND COUNTRY OF ORIGIN.
3. MOUNTING MUST NOT RESTRICT THIS DIAMETER.
4. ALLOW [0.0026 SQ M]/4.0 SQ IN. (MIN.) FOR COOLING AIR INTAKE.
5. COOLING AIR INTAKE MUST BE SEPARATED FROM COOLING AIR EXHAUST.
6. COOLING AIR EXHAUST MUST BE SEPARATED FROM VACUUM EXHAUST.

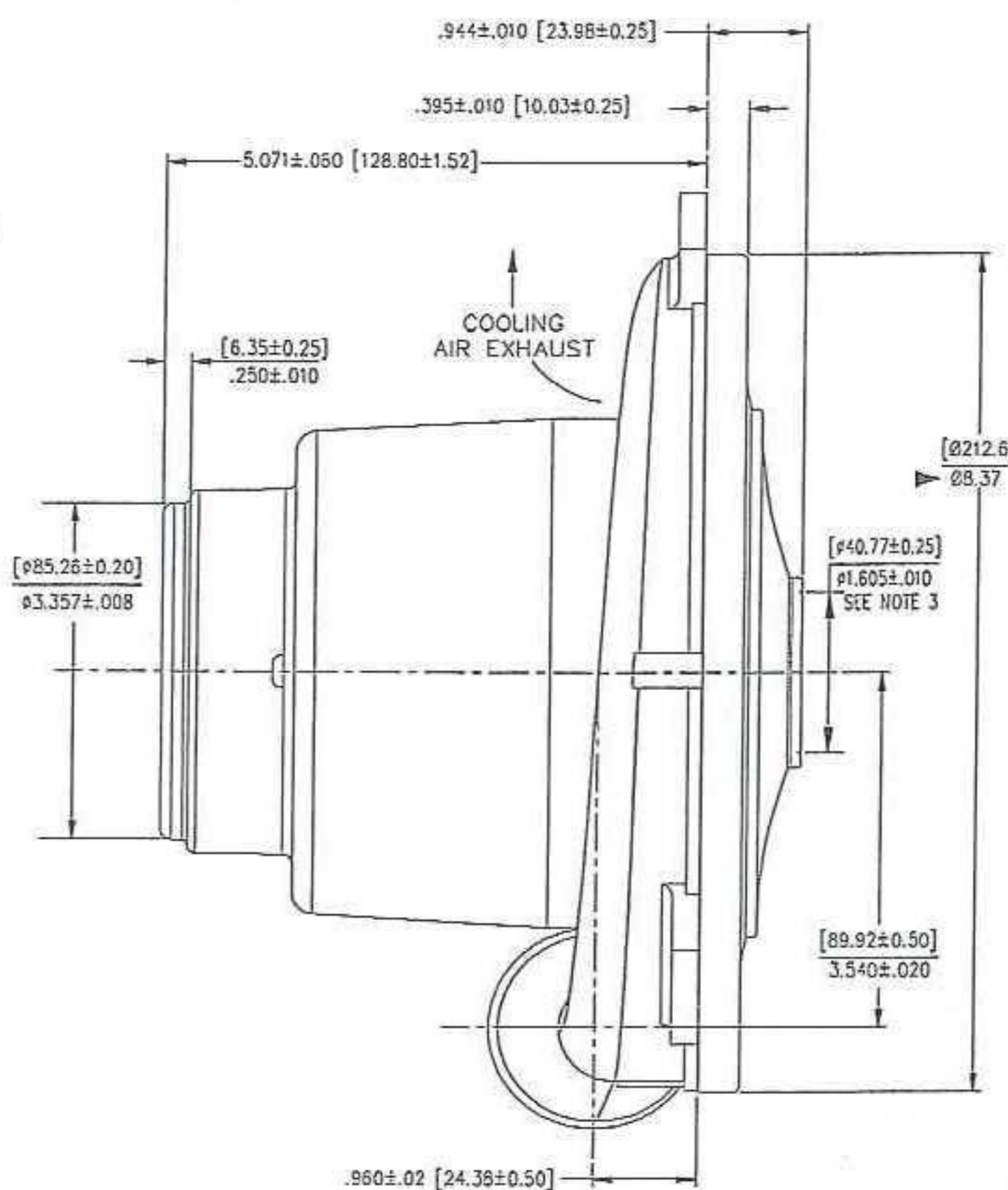
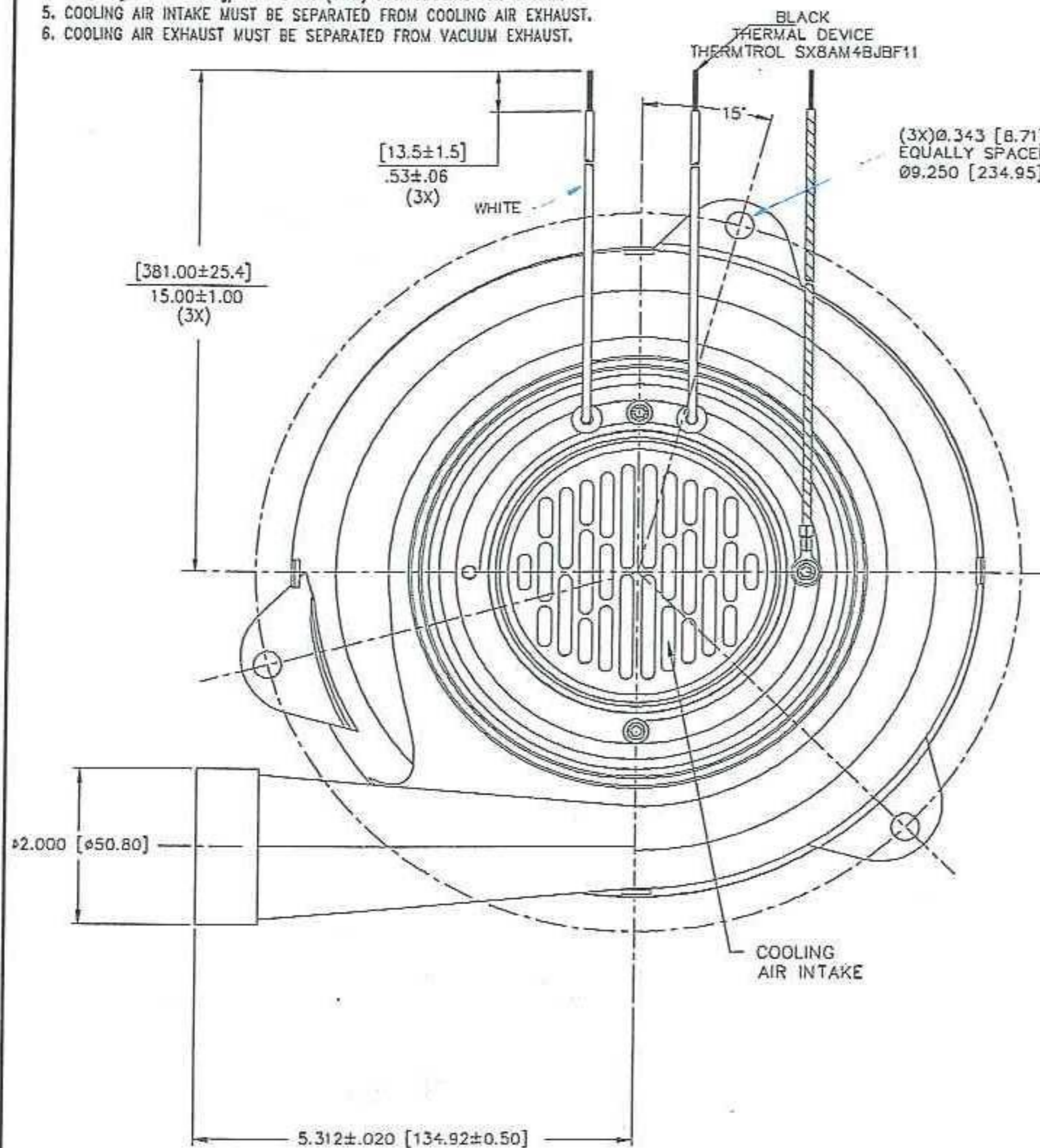

**IMPORTANT NOTE:** Pictorial and dimensional data are subject to change without notice. Contact factory for current revision levels.

**WARNING** - When using AMETEK Floorcare & Specialty Motors (F&SM) bypass motors in machines that come in contact with foam, liquid (including water), or other foreign substances, the machine must be designed and constructed to prevent those substances from reaching the fan system, motor housing, and electrical components. F&SM vacuum motors other than hazardous duty models should not be applied in machines that come in contact with dry chemicals or other volatile materials. Failure to observe these precautions could cause flashing (depending on volatility) or electrical shock which could result in property damage and severe bodily injury, including death in extreme cases. All applications incorporating F&SM motors should be submitted to appropriate organizations or agencies for testing specifically related to the safety of your equipment.

**AMETEK/Floorcare & Specialty Motors**  
**www.ametekfsm.com**

Issued: June, 2008