



**Model: 119656-00**

**DESCRIPTION**

- Two stage
- 240 volts
- 5.7"/145 mm diameter
- Double ball bearings
- Single speed
- Peripheral bypass discharge
- Thermoset fan end bracket
- Aluminum commutator bracket

**DESIGN APPLICATION**

- Equipment operating in environments requiring separation of working air from motor ventilating air
- Designed to handle clean, dry, filtered air only

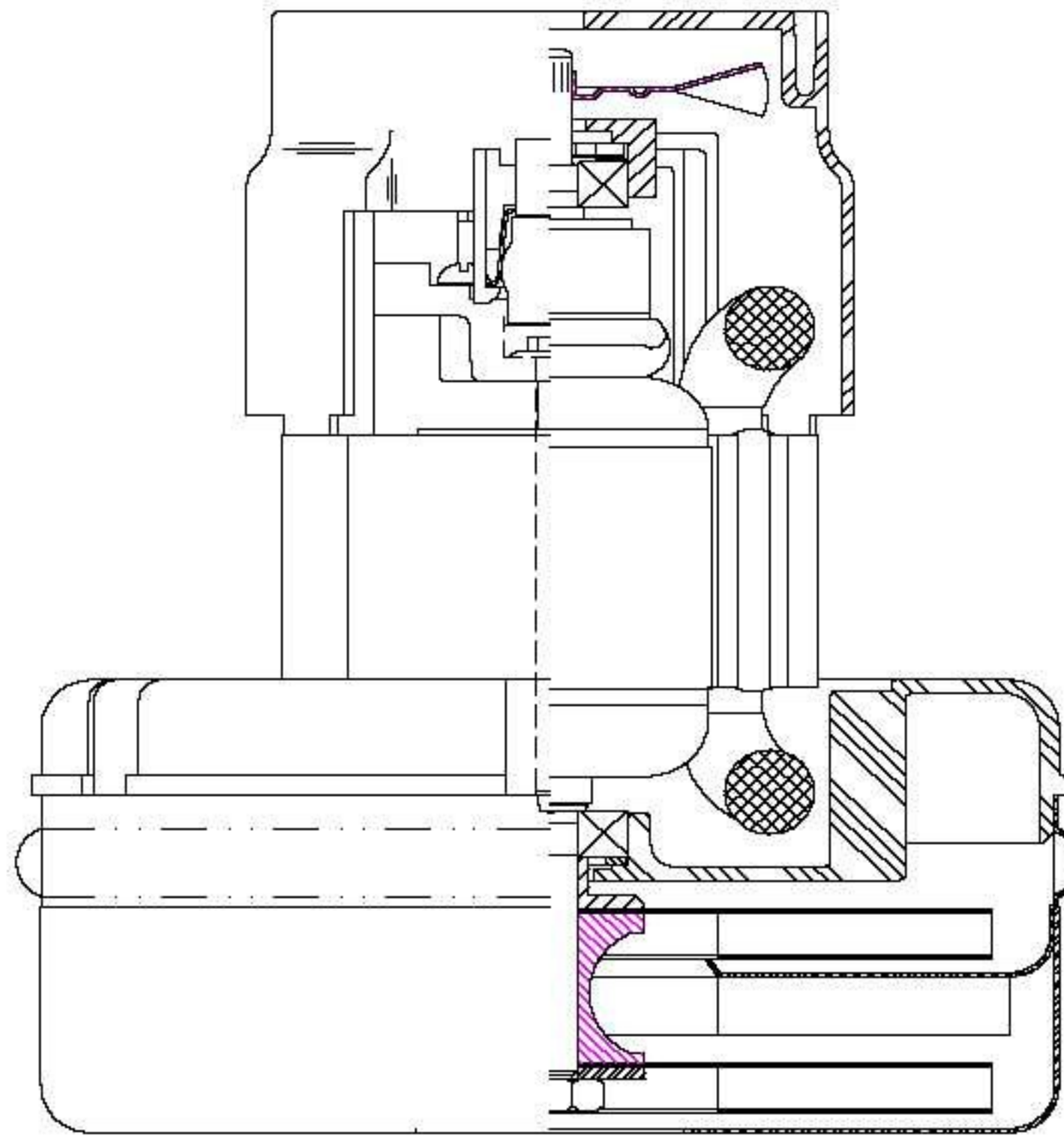

**SPECIAL FEATURES**

- Suitable for 240 volt AC operation, 50/60 Hz
- UL recognized, category PRGY2 (E47185)
- Provision for grounding
- Open frame design
- The Lamb Electric vacuum motor line offers a wide range of performance levels to meet design needs

**TYPICAL MOTOR PERFORMANCE.\***

(At 240 volts, 60Hz, test data is corrected to standard conditions of 29.92 Hg, 68° F.)

**ASTM DATA**

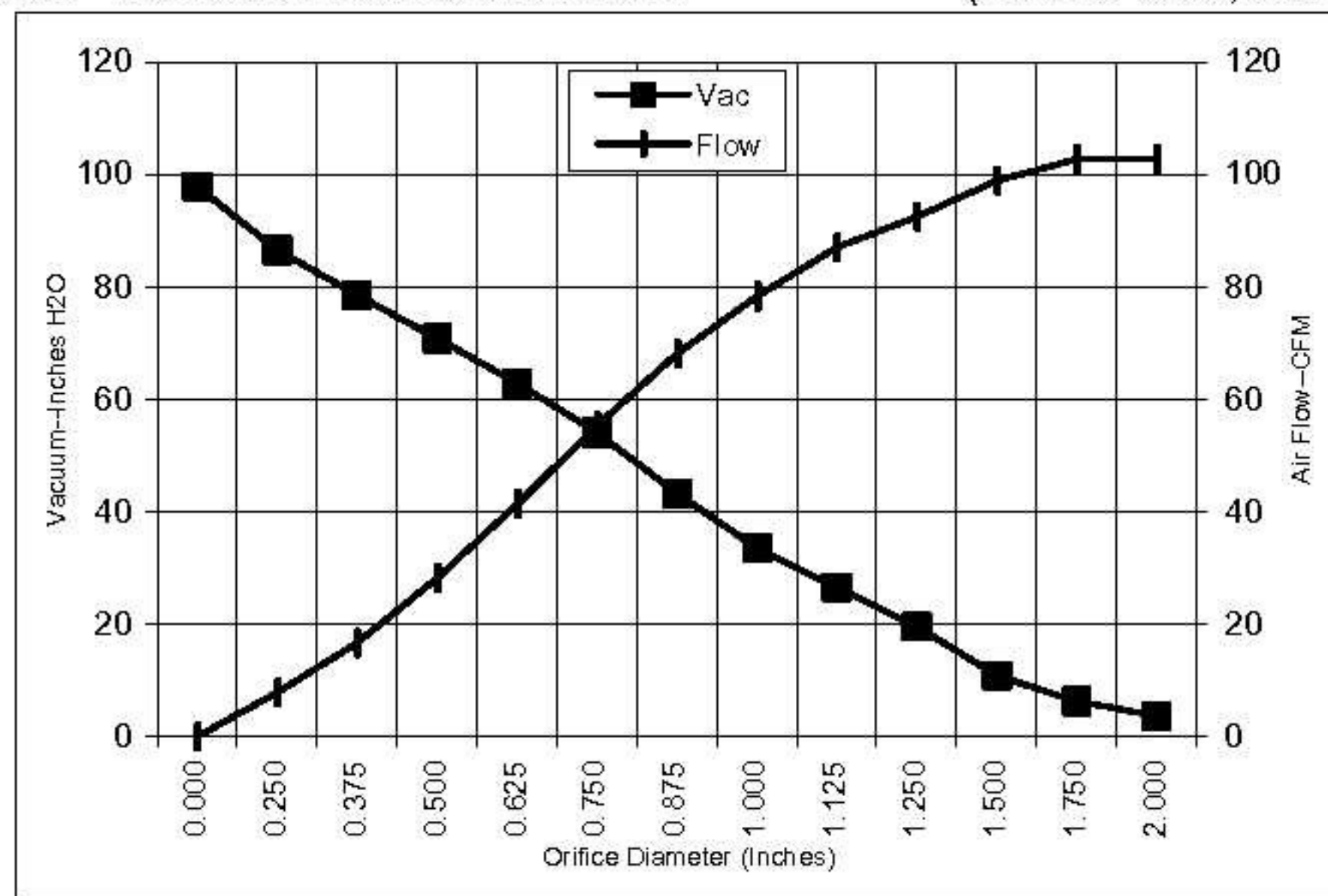

Orifice (Inches)	Amps	Watts (In)	RPM	Vac (In.H <sub>2</sub> O)	Flow (CFM)	Air Watts
2.000	4.9	1144	19217	3.7	102.7	44.6
1.750	4.9	1151	19183	6.3	102.6	75.9
1.500	5.0	1154	19083	10.8	98.8	125.5
1.250	5.0	1164	19050	19.6	92.4	212.8
1.125	5.0	1167	19033	26.5	87.0	270.6
1.000	5.0	1157	19150	33.5	78.3	316.4
0.875	4.9	1128	19358	43.3	68.1	355.1
0.750	4.7	1079	19767	54.1	55.3	351.1
0.625	4.4	1022	20442	62.8	41.3	304.7
0.500	4.1	952	21317	70.8	28.1	233.5
0.375	3.8	882	22367	78.5	16.6	153.2
0.250	3.4	810	23517	86.5	7.8	78.8
0.000	3.2	754	24400	97.8	0.0	0

**METRIC DATA**

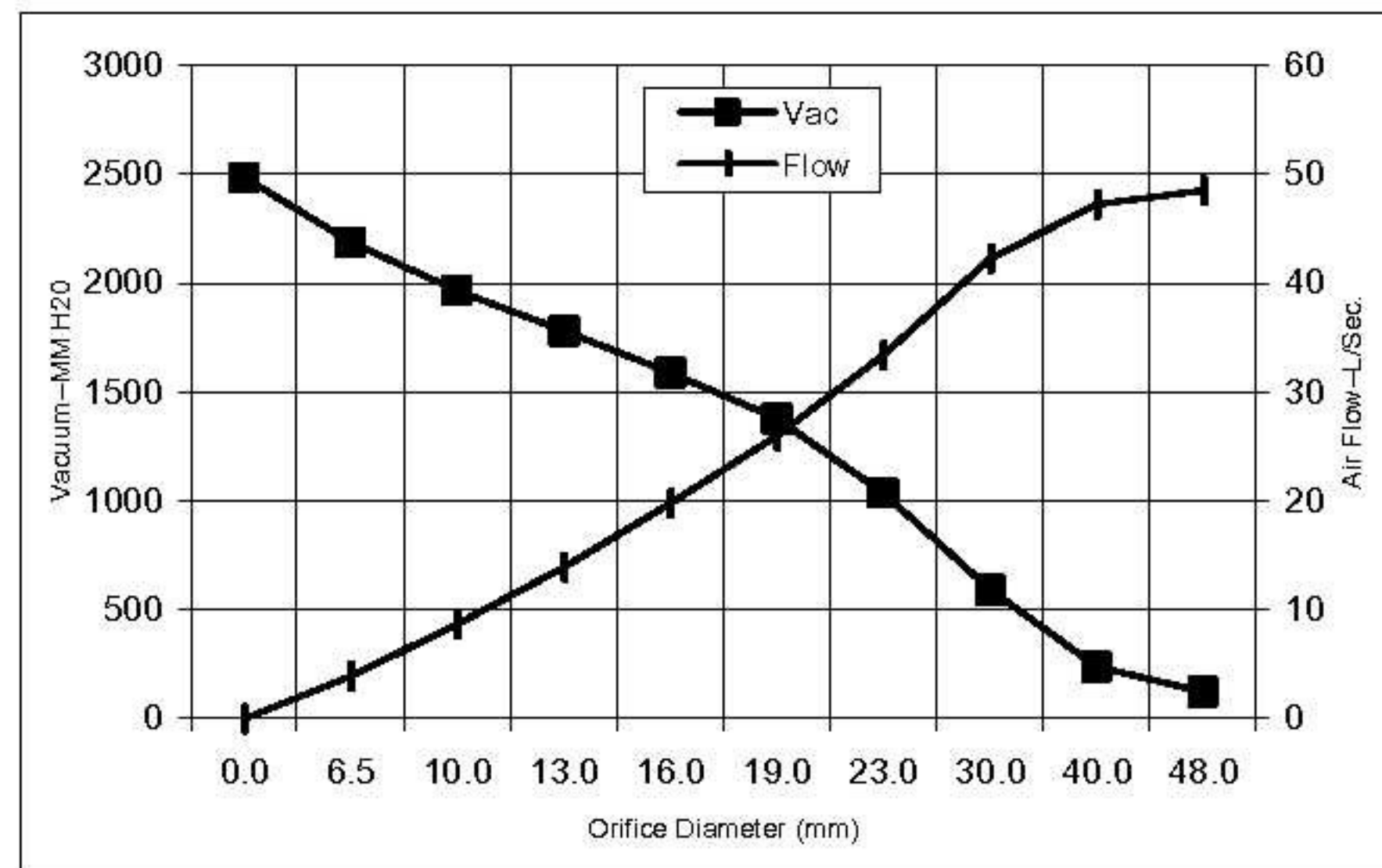

Orifice (mm)	Amps	Watts (In)	RPM	Vac (mm H <sub>2</sub> O)	Flow (L/Sec)	Air Watts
48.0	4.9	1147	19202	123	48.5	58
40.0	4.9	1153	19113	240	47.2	111
30.0	5.0	1166	19041	594	42.2	245
23.0	4.9	1135	19306	1037	33.3	345
19.0	4.7	1078	19781	1379	26.0	350
16.0	4.4	1024	20415	1586	19.8	307
13.0	4.1	959	21230	1778	13.9	241
10.0	3.8	893	22210	1965	8.6	165
6.5	3.4	814	23460	2187	3.9	83
0.0	3.2	754	24400	2484	0.0	0

Note: Metric performance data is calculated from the ASTM data above.

\* Data represents performance of a typical motor sampled from a large production quantity. Individual motor data may vary due to normal manufacturing variations.

<b>Test Specs:</b> 240 volts	<b>Minimum Sealed Vacuum:</b> 90.0"	<b>ORIFICE:</b> 13 mm	<b>Minimum Vacuum:</b> 66.0"	<b>Maximum Watts:</b> 1100
------------------------------	-------------------------------------	-----------------------	------------------------------	----------------------------



**DIMENSIONS**

NOTES:

1. LEADS: 18GA STRANDED. LEADS CAN BE ANY COLOR EXCEPT GREEN OR GREEN WITH YELLOW STRIPE.
2. GROUNDING OR EARTHING PROVISIONS: USE HOLES AS INDICATED FOR GROUNDING OR EARTHING. REFER TO APPROPRIATE LISTING OR REGULATORY AGENCY FOR PROPER METHOD OF GROUNDING OR EARTHING.
3. MOTOR IDENTIFICATION: MANUFACTURER'S NAME, MODEL NUMBER, VOLTAGE, FREQUENCY, INSPECTORS CODE, DATE OF MANUFACTURE, AGENCY RECOGNITION CODE, PLANT LOCATION CODE, PATENT INFORMATION. \*ONE OR MORE OF THE FOLLOWING PATENTS APPLY TO THIS MOTOR: 548237B; 5736805; 4669952; 4684835\*. AND COUNTRY OF ORIGIN.
4. ALLOW [0.0016 SQ M]/2.5 SQ IN. MIN. FOR COOLING AIR INTAKE.
5. COOLING AIR INTAKE MUST BE SEPERATED FROM COOLING AIR EXHAUST.
6. VACUUM EXHAUST MUST BE SEPERATED FROM COOLING AIR EXHAUST.
7. MOUNTING MUST NOT RESTRICT THIS DIAMETER.

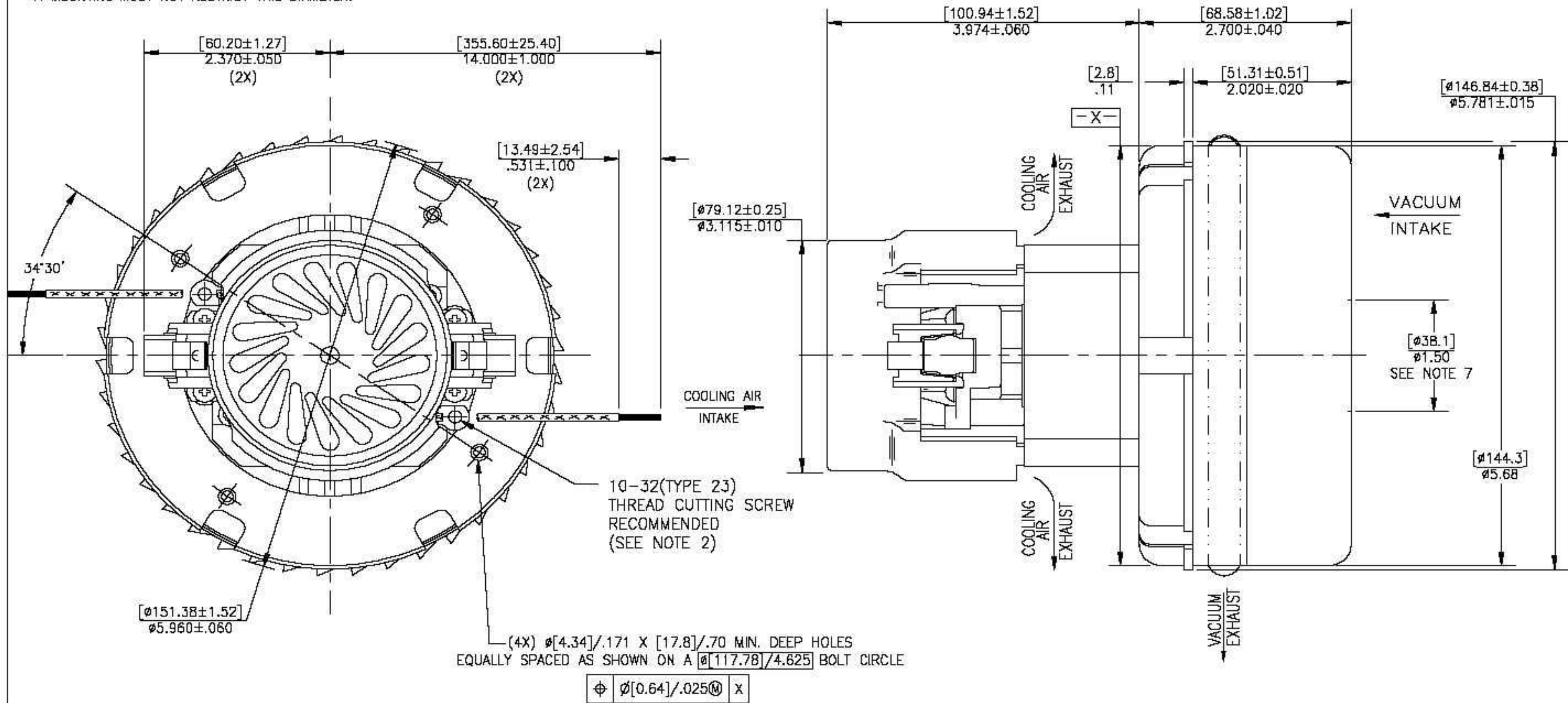

**IMPORTANT NOTE:** Pictorial and dimensional data are subject to change without notice. Contact factory for current revision levels.

**WARNING** - When using AMETEK Lamb Electric bypass motors in machines that come in contact with foam, liquid (including water), or other foreign substances, the machine must be designed and constructed to prevent those substances from reaching the fan system, motor housing, and electrical components. Lamb Electric vacuum motors other than hazardous duty models should not be applied in machines that come in contact with dry chemicals or other volatile materials. Failure to observe these precautions could cause flashing (depending on volatility) or electrical shock which could result in property damage and severe bodily injury, including death in extreme cases. All applications incorporating Lamb Electric motors should be submitted to appropriate organizations or agencies for testing specifically related to the safety of your equipment.

**AMETEK Lamb Electric**  
 627 Lake Street  
 Kent, Ohio 44240  
 U.S.A.  
 Tel: (330) 673-3451  
 Fax: (330) 673-8994

**AMETEK GmbH**  
 P. O. Box 1251  
 D-71667 Marbach  
 Germany  
 Tel: +49-0714-4849512  
 Fax: +49-0714-484-9513

**AMETEK Singapore Pvt. Ltd.**  
 10 Ang Mo Kio Street 65  
 # 05-12 Techpoint  
 Singapore 2056  
 Tel: + 65-484-2388  
 Fax: + 65-481-6588