



Model: 116296-00
116296-13*

DESCRIPTION

- Two stage
- 240 volts
- 5.7"/145 mm diameter
- Double ball bearings
- Single speed
- ACUSTEK® low-noise peripheral bypass discharge
- Thermoset fan end bracket
- Aluminum commutator bracket

DESIGN APPLICATION

- Equipment operating in environments requiring separation of working air from motor ventilating air
- Designed to handle clean, dry, filtered air only

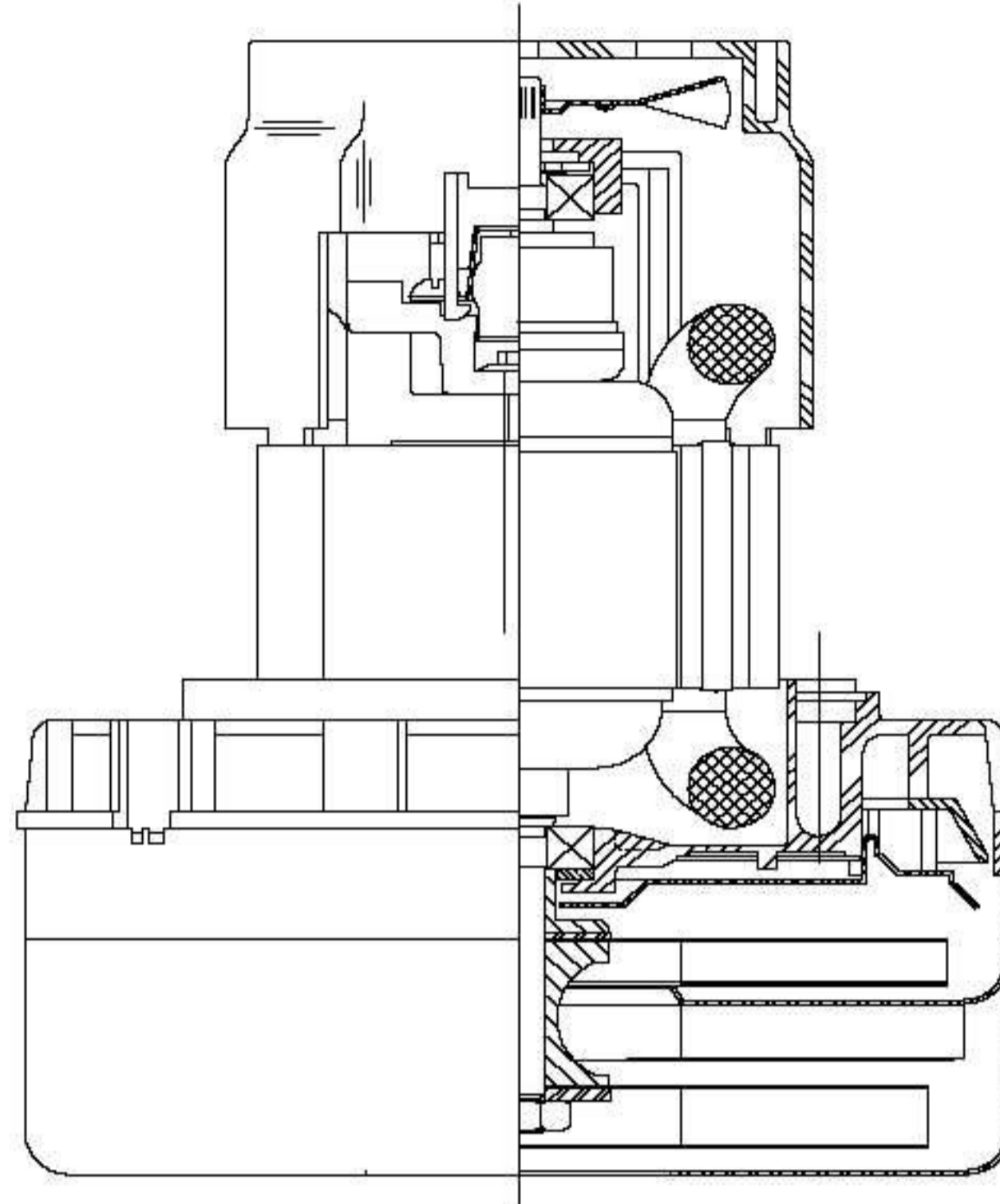

SPECIAL FEATURES

- Suitable for 240 volt AC operation, 50/60 Hz
- UL recognized, category PRGY2 (E47185)
- Provision for grounding
- Skeleton-frame design
- ACUSTEK® low-noise design, U.S. Patent #1,417,2000
- The Lamb Electric vacuum motor line offers a wide range of performance levels to meet design needs

***Model 116296-13 features patented air seal bearing construction. U.S. Patent #4,088,424 and epoxy painted fan case**

TYPICAL MOTOR PERFORMANCE.*

(At 240 volts, 60Hz, test data is corrected to standard conditions of 29.92 Hg, 68° F.)

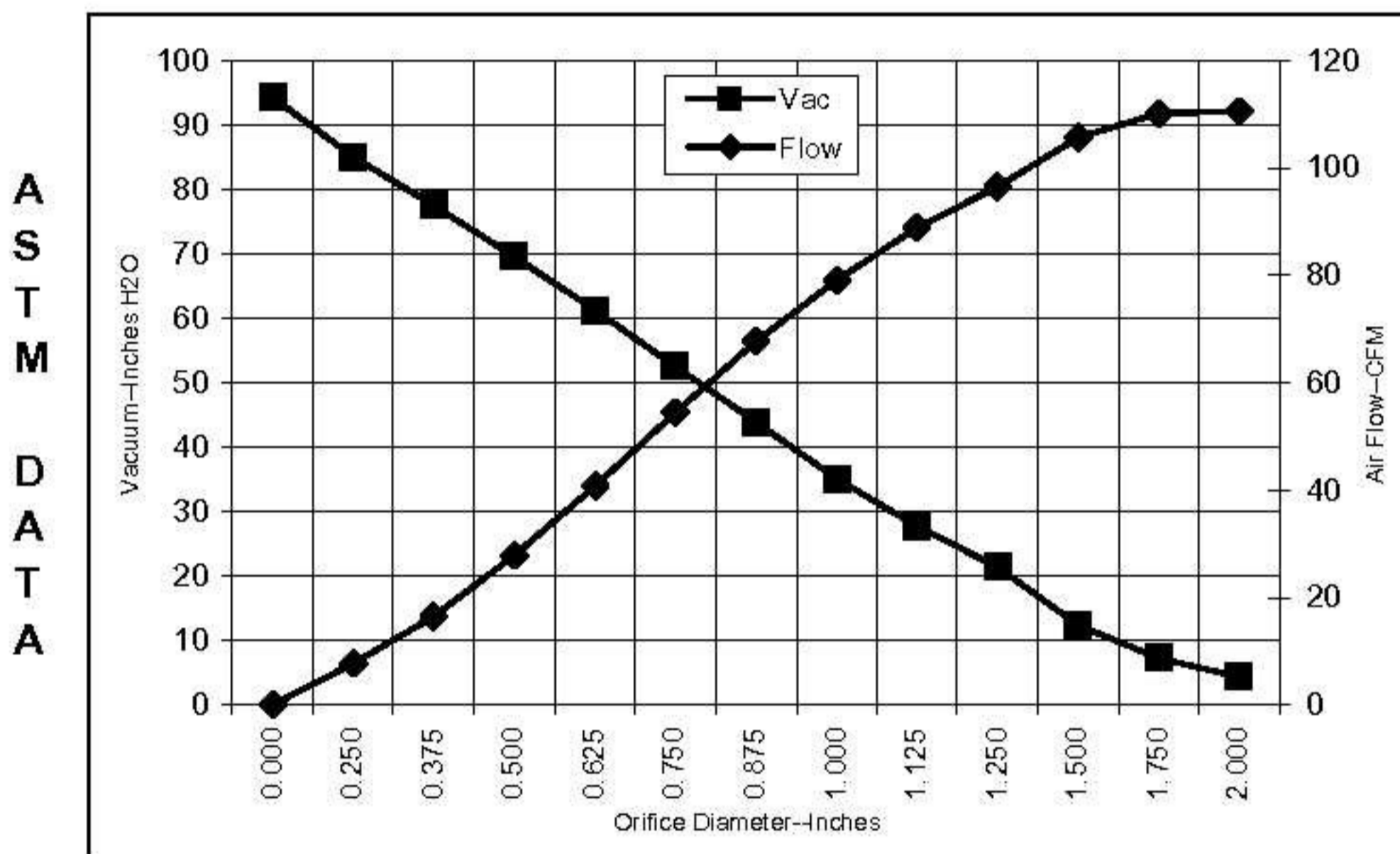

| Orifice (Inches) | Amps | Watts (In) | RPM | Vac (In.H2O) | Flow (CFM) | Air Watts |
|------------------|------|------------|-------|--------------|------------|-----------|
| 2.000 | 4.6 | 1064 | 19390 | 4.3 | 110.5 | 56 |
| 1.750 | 4.6 | 1071 | 19390 | 7.3 | 110.1 | 94 |
| 1.500 | 4.6 | 1077 | 19390 | 12.4 | 105.7 | 154 |
| 1.250 | 4.6 | 1077 | 19390 | 21.4 | 96.5 | 243 |
| 1.125 | 4.6 | 1073 | 19420 | 27.7 | 88.9 | 289 |
| 1.000 | 4.6 | 1067 | 19480 | 35.1 | 79.1 | 326 |
| 0.875 | 4.6 | 1049 | 19620 | 43.9 | 67.7 | 349 |
| 0.750 | 4.4 | 997 | 19990 | 52.5 | 54.4 | 335 |
| 0.625 | 4.1 | 959 | 20710 | 61.2 | 40.8 | 293 |
| 0.500 | 3.8 | 890 | 21600 | 69.5 | 27.8 | 227 |
| 0.375 | 3.5 | 818 | 22660 | 77.5 | 16.5 | 150 |
| 0.250 | 3.2 | 757 | 23730 | 85.0 | 7.7 | 77 |
| 0.000 | 3.0 | 702 | 24850 | 94.2 | 0.0 | 0 |

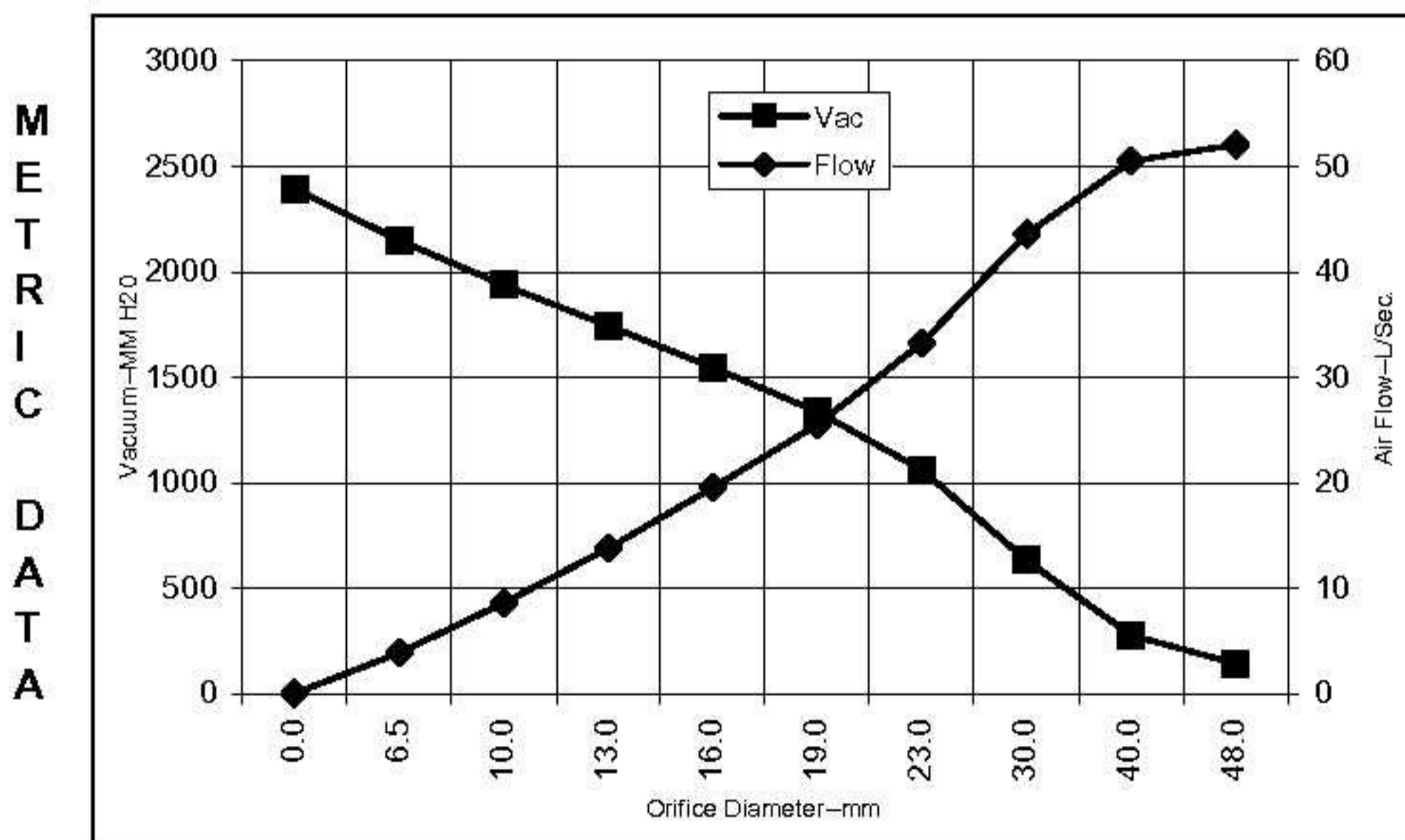

| Orifice (mm) | Amps | Watts (In) | RPM | Vac (mm H2O) | Flow (L/Sec) | Air Watts |
|--------------|------|------------|-------|--------------|--------------|-----------|
| 48.0 | 4.6 | 1067 | 19390 | 142 | 52.1 | 73 |
| 40.0 | 4.6 | 1075 | 19390 | 275 | 50.5 | 136 |
| 30.0 | 4.6 | 1075 | 19407 | 631 | 43.6 | 268 |
| 23.0 | 4.6 | 1054 | 19585 | 1059 | 33.3 | 343 |
| 19.0 | 4.4 | 996 | 20004 | 1337 | 25.5 | 334 |
| 16.0 | 4.1 | 961 | 20681 | 1546 | 19.5 | 295 |
| 13.0 | 3.8 | 897 | 21511 | 1745 | 13.7 | 234 |
| 10.0 | 3.5 | 829 | 22501 | 1938 | 8.6 | 162 |
| 6.5 | 3.2 | 760 | 23677 | 2149 | 3.8 | 81 |
| 0.0 | 3.0 | 702 | 24850 | 2392 | 0.0 | 0 |

Note: Metric performance data is calculated from the ASTM data above.

* Data represents performance of a typical motor sampled from a large production quantity. Individual motor data may vary due to normal manufacturing variations.

| | | | | |
|------------------------------|-------------------------------------|----------------------|------------------------------|----------------------------|
| Test Specs: 240 volts | Minimum Sealed Vacuum: 88.0" | ORIFICE: 13mm | Minimum Vacuum: 65.0" | Maximum Watts: 1000 |
|------------------------------|-------------------------------------|----------------------|------------------------------|----------------------------|

DIMENSIONS

NOTES:

1. LEADS: 18GA STRANDED, LEADS CAN BE ANY COLOR EXCEPT GREEN OR GREEN WITH YELLOW STRIPE.
2. GROUNDING OR EARTHING PROVISIONS: USE HOLES AS INDICATED FOR GROUNDING OR EARTHING. REFER TO APPROPRIATE LISTING OR REGULATORY AGENCY FOR PROPER METHOD OF GROUNDING OR EARTHING.
3. RECOMMENDED SCREW SIZE 10-16 TYPE BT OR 25 THREAD CUTTING SCREW. MAXIMUM PENETRATION 17.40/.685.

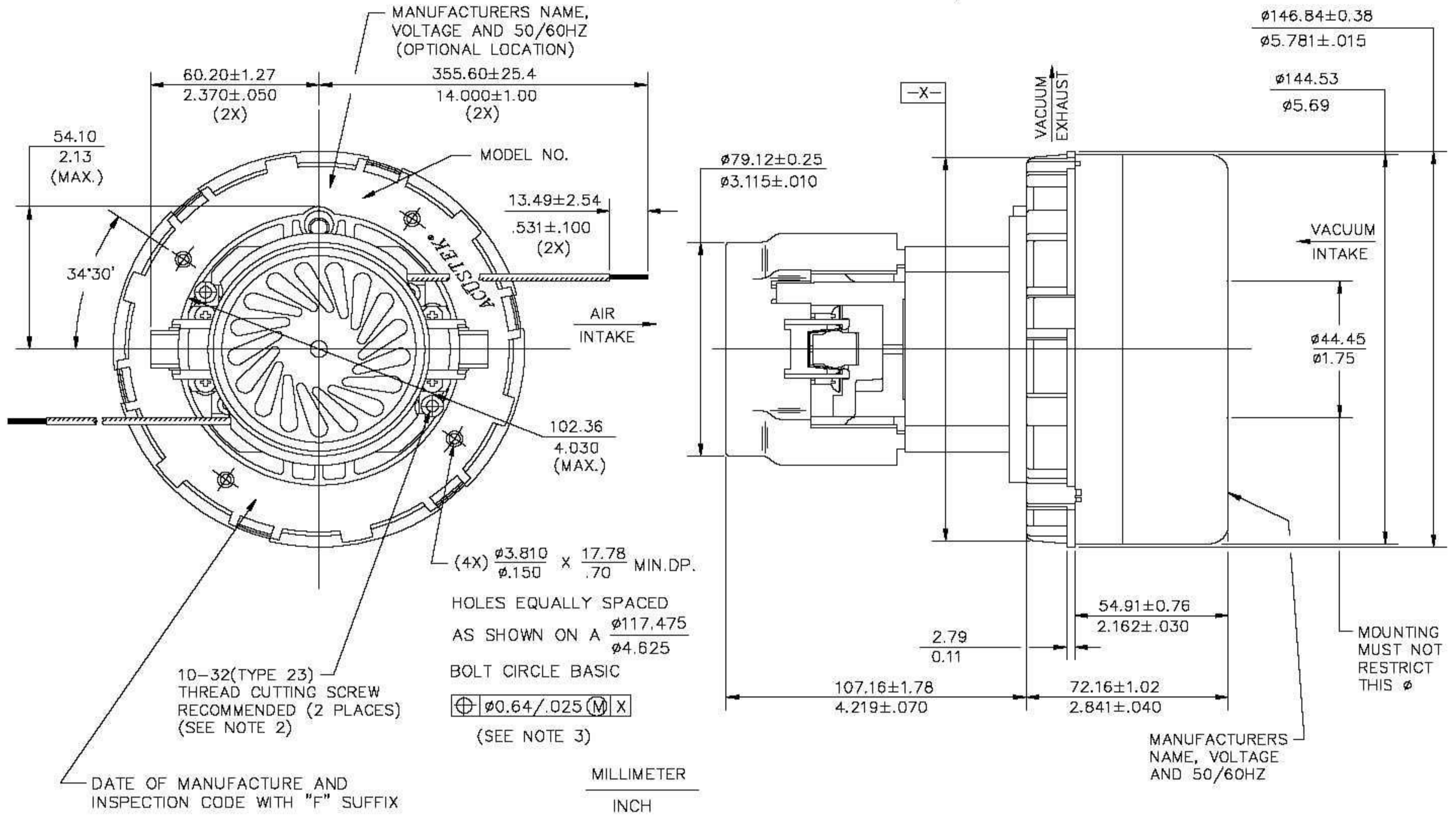

IMPORTANT NOTE: Pictorial and dimensional data are subject to change without notice. Contact factory for current revision levels.

WARNING - When using AMETEK Lamb Electric bypass motors in machines that come in contact with foam, liquid (including water), or other foreign substances, the machine must be designed and constructed to prevent those substances from reaching the fan system, motor housing, and electrical components. Lamb Electric vacuum motors other than hazardous duty models should not be applied in machines that come in contact with dry chemicals or other volatile materials. Failure to observe these precautions could cause flashing (depending on volatility) or electrical shock which could result in property damage and severe bodily injury, including death in extreme cases. All applications incorporating Lamb Electric motors should be submitted to appropriate organizations or agencies for testing specifically related to the safety of your equipment.