

Blackbird Raven Assembly Instructions

Call or text me if you need help:
Matthew Freed
214-918-5132
contact@blackbirdcarts.com

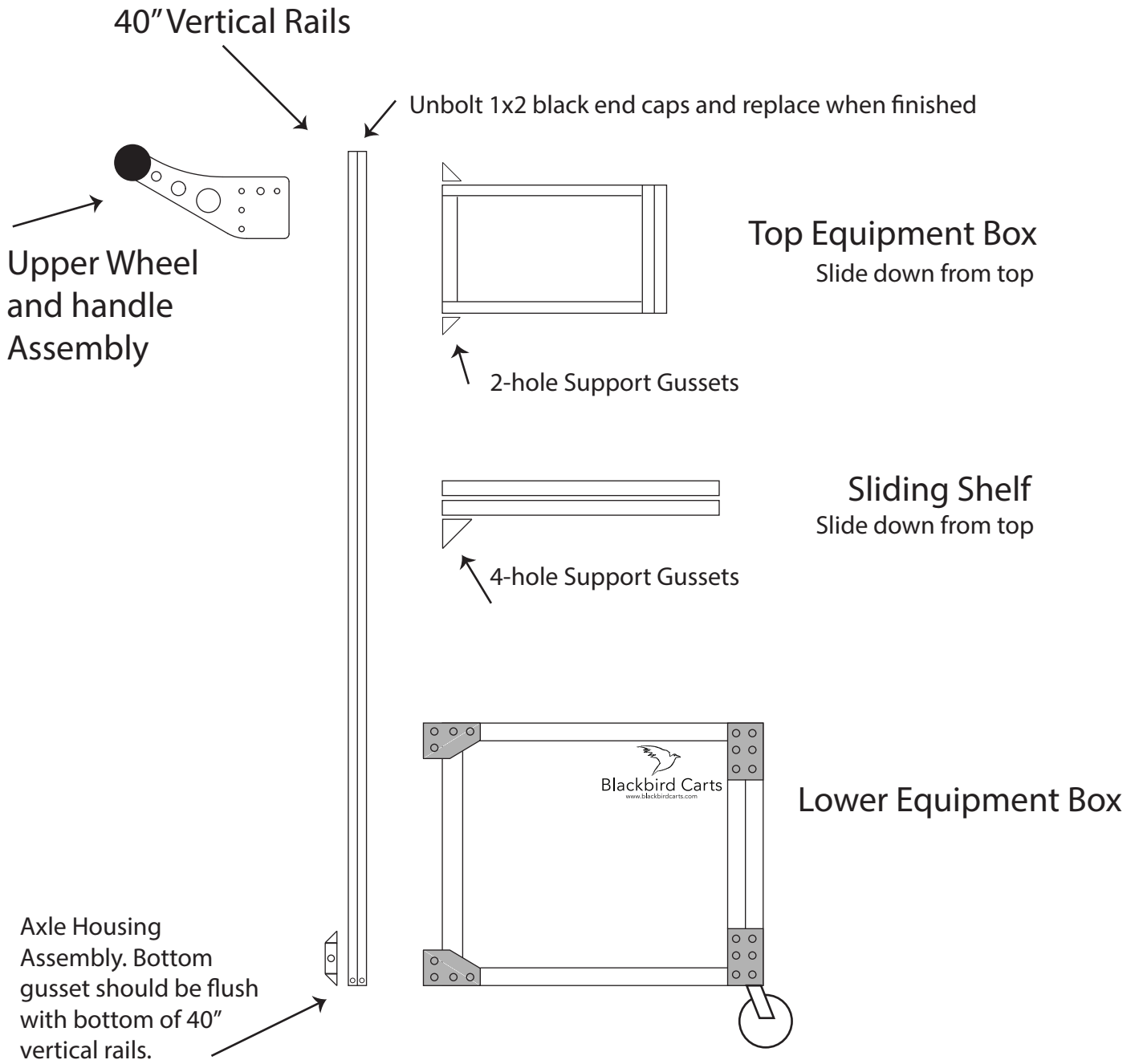

Blackbird Raven Assembly Instructions

Call or text me if you need help:
Matthew Freed
214-918-5132
contact@blackbirdcarts.com

1. Slide 90 degree brackets on to top, back side of Lower Equipment Box. Make flush with back of top rail.

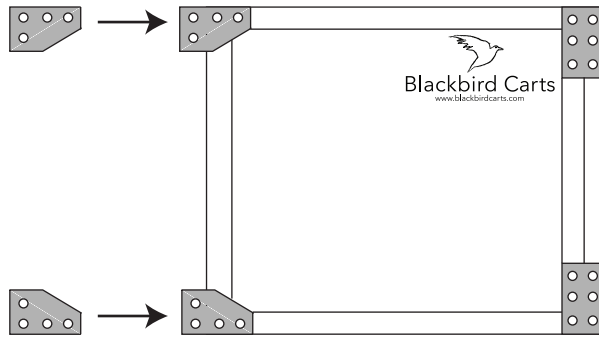

2. Lower 40-inch verticals on to back side of Equipment Box. Make bottom of Vertical Rail flush with bottom of box. Tighten Bolts A through D

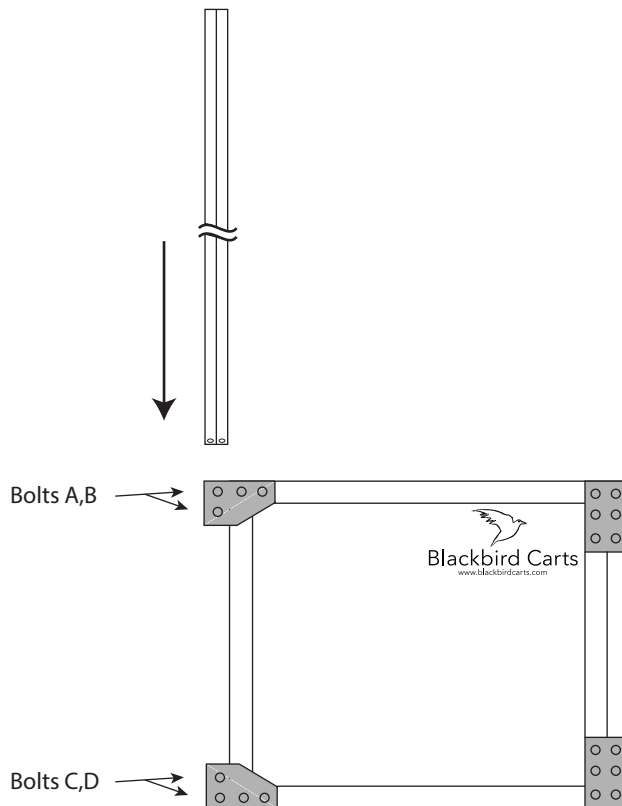

Blackbird Raven Assembly Instructions

Call or text me if you need help:
Matthew Freed
214-918-5132
contact@blackbirdcarts.com

3. Turn assembly upside down and place on a tabletop to install caster wheels and rear axle assembly.

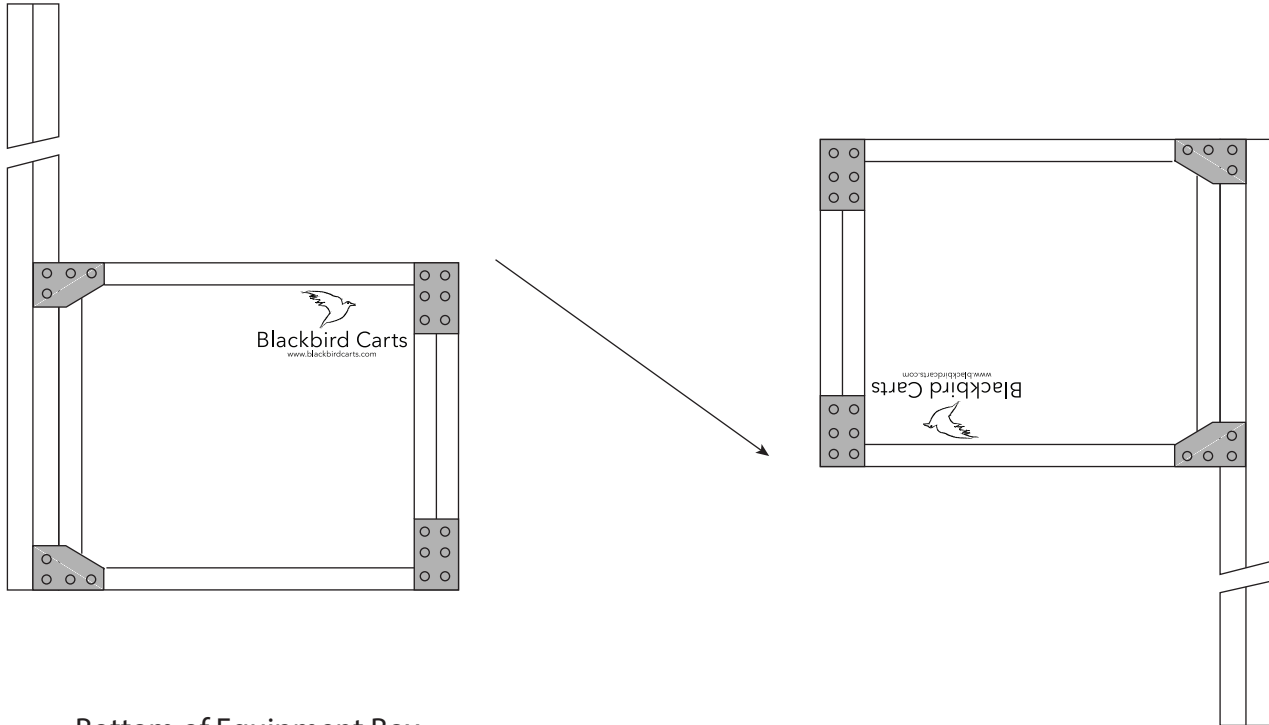

Bottom of Equipment Box

Install 3 washers and bolts into T-Nuts that have been pre-installed in rails.

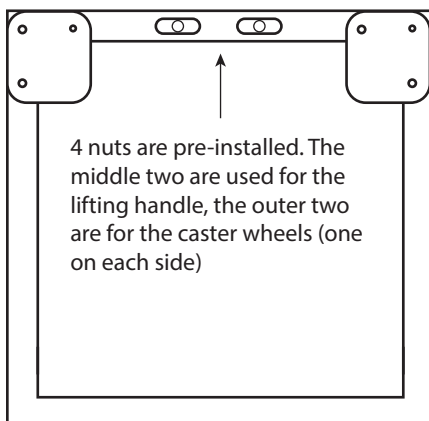

4 nuts are pre-installed. The middle two are used for the lifting handle, the outer two are for the caster wheels (one on each side)

Caster Wheel Plates

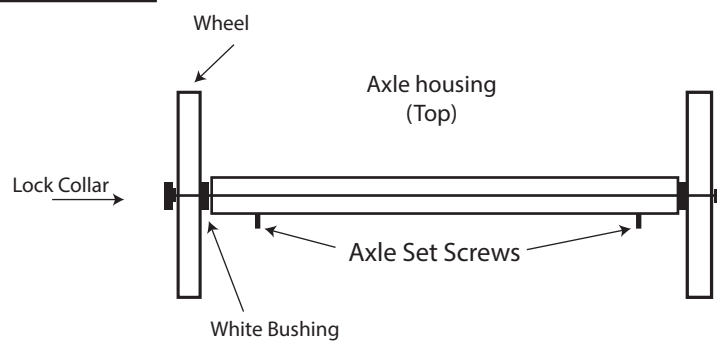
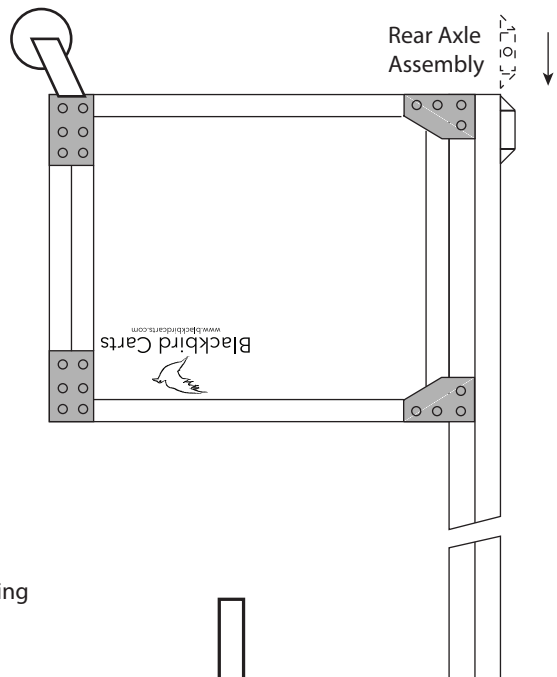

Blackbird Raven Assembly Instructions

Call or text me if you need help:
Matthew Freed
214-918-5132
contact@blackbirdcarts.com

4. Place assembly on all 4 wheels on the floor. Then, slide mixer shelf down from top and follow with Upper Monitor Box. Tighten bolts to secure in place.

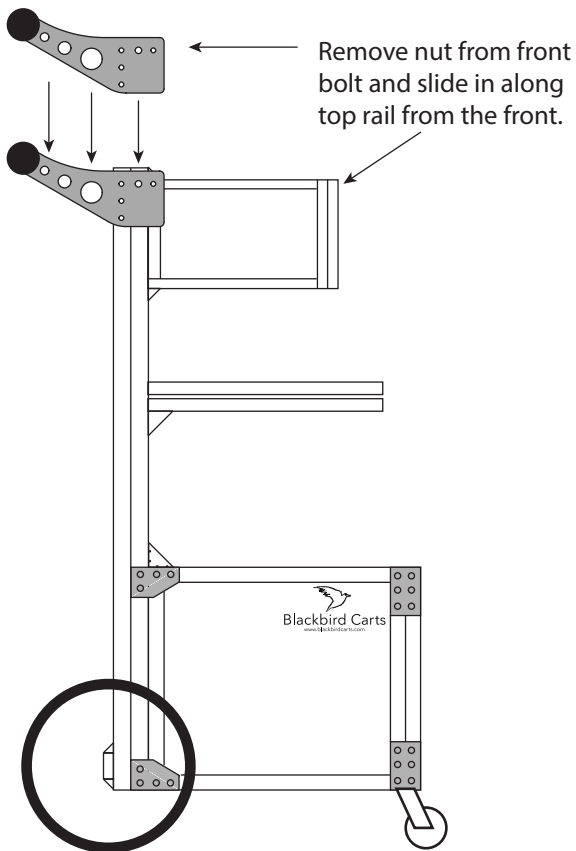
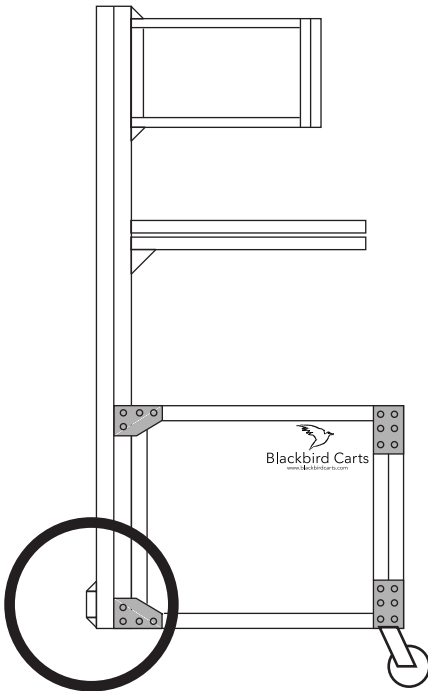

5. Slide Top Handle Assembly down onto outside of vertical rails and align top holes with top rails of the Monitor Box. A T-Nut has been pre-installed in top rail of Monitor Box for forward most bolt.

6. Replace any remaining end caps and bolts into extrusion ends. Check all bolts for tightness.