

Grackle Assembly Instructions

Call or Text me when/if you need help:
Matthew Freed
214-918-5132
contact@blackbirdcarts.com

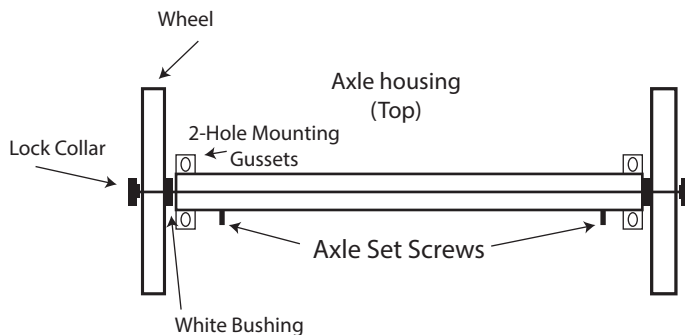

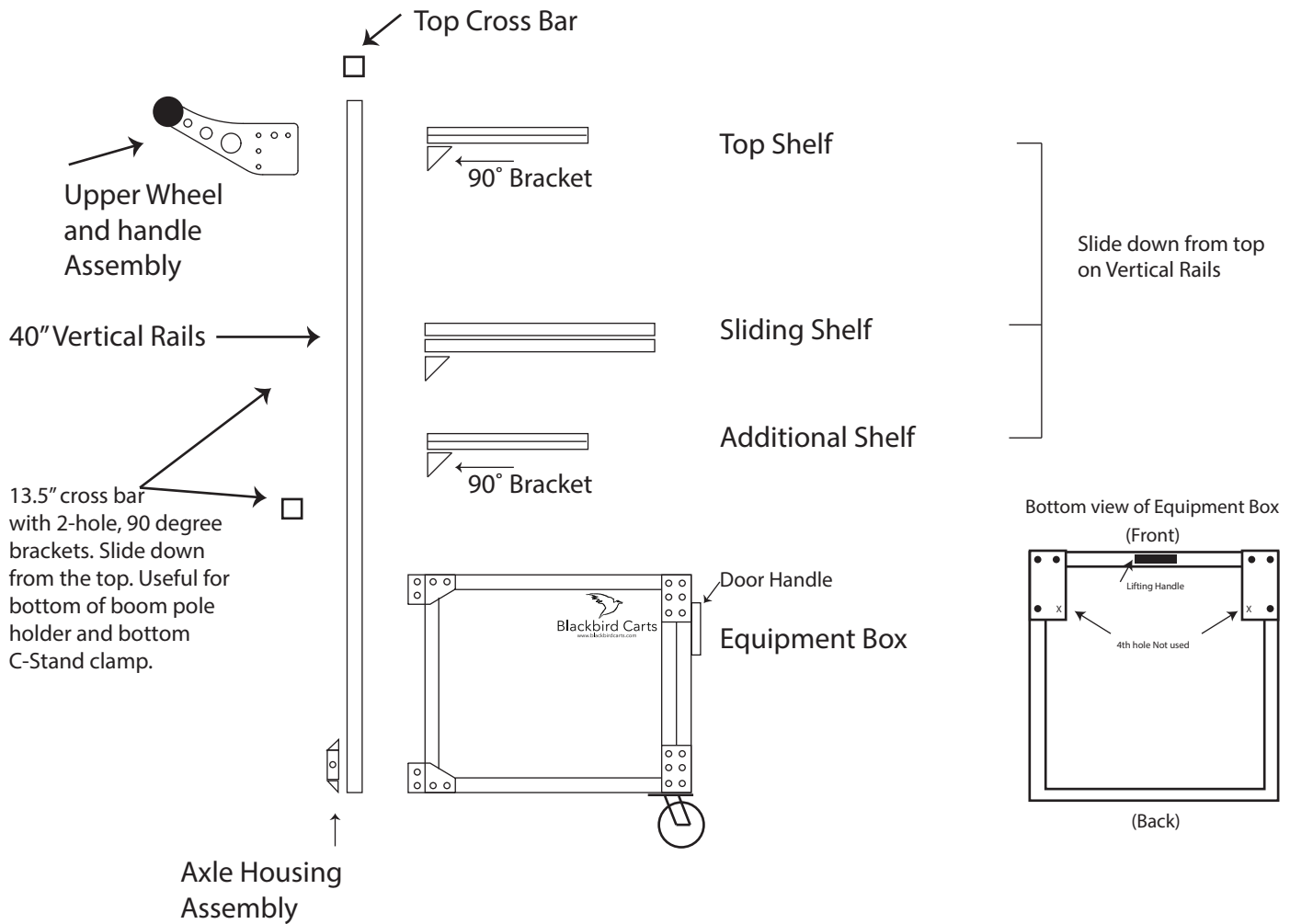

Grackle Assembly Instructions

Call or Text me when/if you need help:
Matthew Freed
214-918-5132
contact@blackbirdcarts.com

All bracket and mounting bolts are pre-assembled. All bolts/nuts were made snug for shipping purposes. Simply loosen them to assemble but do not remove the nuts entirely (it's easier to assemble with them on). When assembling, the bolts/nuts should be tightened down but they don't need to be cranked down hard to the point of stripping.

Assembly:

1. Slightly loosen the bolts/nuts on the rear blue brackets, but do not remove the nuts.
2. Remove black end caps from vertical rails and set aside. Replace when done. Position 40" vertical rails as shown on previous page and slide down onto the equipment box making the bottom of the rail flush with the bottom of the box. End Fastener Assemblies can be accessed via the holes in the rails.
3. Attach front caster wheels. The nuts for one of the front holes are already placed in the rails, bolts are in the bag labeled "Caster Hardware." Slide two T-Nuts into the bottom Z-Axis rails from the front and use these for the outer two holes on the caster wheels. Use one washer per bolt. Only 3 bolts are needed; the 4th hole on the caster wheel plate is not used.
4. Attach rear axle housing to back side of 40" rails. The two set screws are placed facing downward. Slide the entire housing up from the bottom and make just tight enough to hold it. You'll want to adjust it to level the cart later and tighten the screws at that point. Adjust height as needed to make cart level.
5. Attach sliding mixer shelf by sliding down from the top. The 90 degree brackets go on the bottom side. Loosen the bolts slightly but do not remove them. Slide the shelf down from the top of the vertical rails placing at desired height and tighten bolts to hold in place.
6. Install two 90 degree black brackets at the back side of the top shelf. Slide down from the top of the 40" vertical rails to desired height. Remove the 2-hole T-Nut from the blue brackets and slide along the outer slots on the top shelf with the little nubs facing inward. Take top handle/wheel assembly and slide down vertical rails so the top of the blue plate is about 3 inches from top of the vertical rail. Slide the 2-hole T-Nut back to the blue plate and align with front two bolts. Tighten bolts to hold in place.
10. Take the cross bar (the loose rail that is 13.5" long and has two 90 degree bracket assemblies attached). Slightly loosen the nuts from the end fasteners and slide the rail between the top end of the vertical rails. Place about 15" up from the floor. Slightly loosen outer bolts on blue plates to relieve the pressure on the vertical rails so the 13.5" piece slides down easier. Do the same with the top cross bar that has the two end fasteners.
11. Check all bolts to make sure they're tight and replace any end caps that were removed.