



PRIMA 16 INCH STEM HUNG PENDANT LIGHT

STB125

Stem hung pendants are UL wet rated for outdoor use. Choose from multiple vertical stem lengths to suit your application. Outdoor hanging pendant lights work well on a porch, in a garage or workshop. A secure mount for commercial as well as residential exterior locations. Our Prima shade is elegant and clean-lined, inspiring illumination of your beautiful view.



FEATURES + BENEFITS

- Metal RLM shades are spun from heavy duty aluminum.
- Dimmable with a dimmable bulb and compatible dimmer (not included).
- Polyester powder coat finish provides color retention and scratch resistance.
- White powder coat shade interior for maximum light output. Painted galvanized finish has painted galvanized shade interior.
- UL Listed for Wet Location.
- Warranty: Limited 1 Year.
- Made in USA.

SPECIFICATIONS

Product Dimensions:

Width 16", Shade Height 10 7/8", Canopy Dia. 4 1/8", Overall Height=Choice of Vertical Stem Length + 11 1/8"

Lamping:

Max Wattage: 100W per socket

Options:

- Finish: Slate Gray, Black, Forest Green, White Gloss, Sea Green, Painted Galvanized, Navy, Architectural Bronze, Light Blue, Barn Red
- Shade Size: 14 Inch, 16 inch
- Accessories: Choice of Vertical Stem Length, Decorative Ceiling Canopy, Weathertight Glass and Guard, Sloped Ceiling Mount, Integrated LED

Shipping:

At Montclair Light Works we proudly manufacture, assemble, and ship your lamp within 7-13 business days from our factory in Montclair CA.

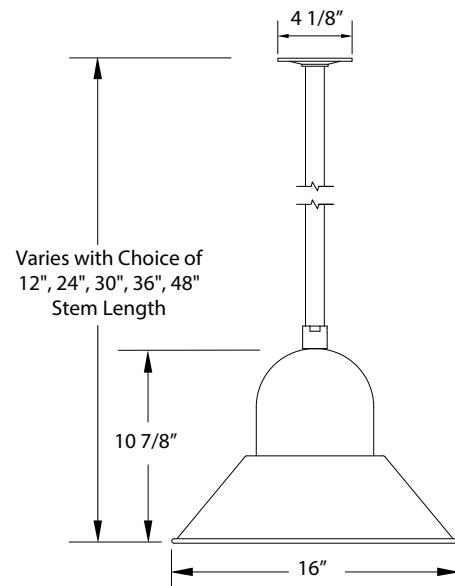

JOB/LOCATION

QUANTITY

DATE

NOTES