



## WAREHOUSE 4-LIGHT STEM HUNG PENDANT LIGHT

MSP181

Maximize your light output with our 4-Light Multi-Light Stem Hung Pendants. Illuminate an outdoor or indoor kitchen island or dining table, this industrial look works well in both commercial and residential applications.



### FEATURES + BENEFITS

- Metal RLM shades are spun from heavy duty aluminum.
- Dimmable with a dimmable bulb and compatible dimmer (not included).
- Polyester powder coat finish provides color retention and scratch resistance.
- White powder coat shade interior for maximum light output. Painted galvanized finish has painted galvanized shade interior.
- UL Listed for Wet Location.
- Warranty: Limited 1 Year.
- Made in USA.

## SPECIFICATIONS

### Product Dimensions:

Shade Width 10", Shade Height 6 1/4", Width 33", Length 33", Canopy Dia. 4 1/8", Overall Height=Choice of Vertical Stem Length + 9"

### Lamping:

Max Wattage: 100W per socket

### Options:

- Finish: Slate Gray, Black, Forest Green, White Gloss, Sea Green, Painted Galvanized, Navy, Architectural Bronze, Light Blue, Barn Red
- Accessories: Choice of Vertical Stem Length, Decorative Ceiling Canopy, Weathertight Glass and Guard, Wire Grill, Sloped Ceiling Mount, Integrated LED

### Shipping:

At Montclair Light Works we proudly manufacture, assemble, and ship your lamp within 7-13 business days from our factory in Montclair CA.

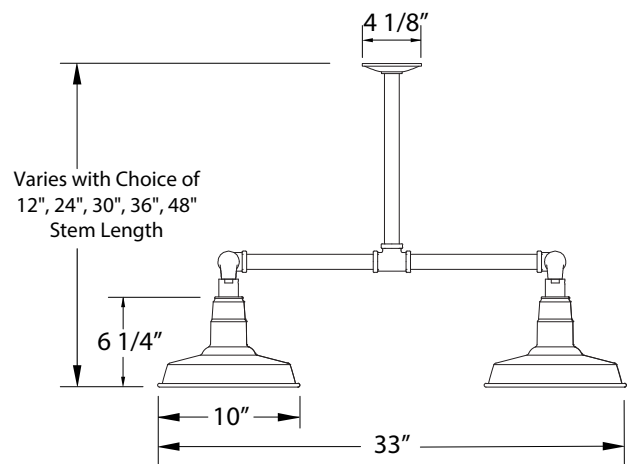

JOB/LOCATION

QUANTITY

DATE

NOTES