

SCHOOLHOUSE 2-LIGHT STEM HUNG PENDANT LIGHT

MSD021

Maximize your light output with our 2-Light Multi-Light Stem Hung Pendants. Illuminate a kitchen island or dining table, this industrial look works well in both commercial and residential applications. Our 12-inch glass Schoolhouse shade is made in the USA and will add a vintage flair to your space.



FEATURES + BENEFITS

- Opal glass Schoolhouse shade, made in the USA.
- Dimmable with a dimmable bulb and compatible dimmer (not included).
- Polyester powder coat finish provides color retention and scratch resistance.
- UL Listed for Dry Location.
- Warranty: Limited 1 Year.
- Made in USA.

SPECIFICATIONS

Product Dimensions:

Width 11 3/4", Shade Height 10 3/4", Length 34 3/4", Canopy Dia. 4 1/8", Overall Height=Choice of Vertical Stem Length + 13 1/2"

Lamping:

Max Wattage: 100W per socket

Options:

- Finish: Slate Gray, Black, Forest Green, White Gloss, Sea Green, Painted Galvanized, Navy, Architectural Bronze, Light Blue, Barn Red
- Accessories: Choice of Vertical Stem Length, Decorative Ceiling Canopy, Sloped Ceiling Mount

Shipping:

At Montclair Light Works we proudly manufacture, assemble, and ship your lamp within 7-13 business days from our factory in Montclair CA.

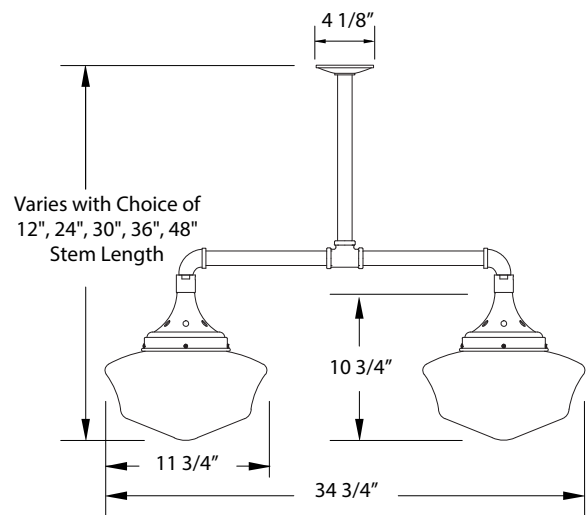

JOB/LOCATION

QUANTITY

DATE

NOTES