



CAFE 2-LIGHT STEM HUNG PENDANT LIGHT

MSB105

Maximize your light output with our 2-Light Multi-Light Stem Hung Pendants. Illuminate an outdoor or indoor kitchen island or dining table, this industrial look works well in both commercial and residential applications. Our Cafe shades will help transform your outdoor living area into a warm and intimate gathering space.



FEATURES + BENEFITS

- Metal RLM shades are spun from heavy duty aluminum.
- Dimmable with a dimmable bulb and compatible dimmer (not included).
- Polyester powder coat finish provides color retention and scratch resistance.
- White powder coat shade interior for maximum light output. Painted galvanized finish has painted galvanized shade interior.
- UL Listed for Wet Location.
- Warranty: Limited 1 Year.
- Made in USA.

SPECIFICATIONS

Product Dimensions:

Width 8", Shade Height 5 3/4", Length 22", Canopy Dia. 4 1/8", Overall Height=Choice of Vertical Stem Length + 8 1/2"

Lamping:

Max Wattage: 100W per socket

Options:

- Finish: Slate Gray, Black, Forest Green, White Gloss, Sea Green, Painted Galvanized, Navy, Architectural Bronze, Light Blue, Barn Red
- Shade Size: 8 Inch, 12 Inch, 16 Inch
- Accessories: Choice of Vertical Stem Length, Decorative Ceiling Canopy, Weathertight Glass and Guard, Wire Grill, Sloped Ceiling Mount, Integrated LED

Shipping:

At Montclair Light Works we proudly manufacture, assemble, and ship your lamp within 7-13 business days from our factory in Montclair CA.

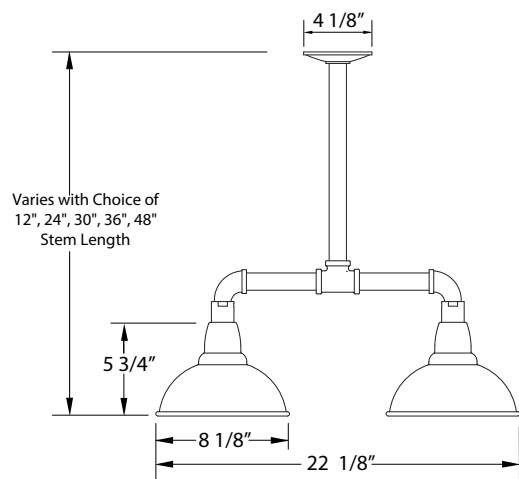

JOB/LOCATION

QUANTITY

DATE

NOTES