



VAPORTITE 2-LIGHT STEM HUNG PENDANT LIGHT

MSA050



Maximize your light output with our Multi-Light Stem Hung Pendants. Illuminate an outdoor or indoor kitchen island or dining table, hang over a sink or in the bath. The industrial look works well in both commercial and residential applications. Our weathertight glass and guard will protect your light source from damage in a storm, as well as light your way in great nautical style.

FEATURES + BENEFITS

- Metal RLM shades are spun from heavy duty aluminum.
- Weathertight Glass and Cast Aluminum Guard protect light source.
- Dimmable with a dimmable bulb and compatible dimmer (not included).
- Polyester powder coat finish provides color retention and scratch resistance.
- White powder coat shade interior for maximum light output. Painted galvanized finish has painted galvanized shade interior.
- UL Listed for Wet Location.
- Warranty: Limited 1 Year.
- Made in USA.

SPECIFICATIONS

Product Dimensions:

Width 4 1/8", Shade Height 9 7/8", Length 15 1/2", Canopy Dia. 4 5/8", Overall Height=Choice of Vertical Stem Length + 11 3/8"

Lamping:

Max Wattage: 100W per socket

Options:

- Finish: Slate Gray, Black, Forest Green, White Gloss, Sea Green, Painted Galvanized, Navy, Architectural Bronze, Light Blue, Barn Red
- Shade Style: No Shade, Angle Shade
- Accessories: Choice of Vertical Stem Length, Decorative Ceiling Canopy, Sloped Ceiling Mount

Shipping:

At Montclair Light Works we proudly manufacture, assemble, and ship your lamp within 7-13 business days from our factory in Montclair CA.

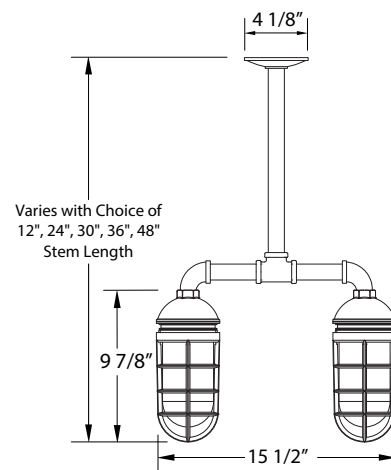

JOB/LOCATION

QUANTITY

DATE

NOTES