

CAFE 8 INCH CURVED ARM WALL LIGHT

GNT105

Our outdoor wall lights, inspired by 1920's industrial lighting, in curved arm styles are great for use as sign or awning lights, garage or barn lights. This vintage look works well indoors also, our smallest sizes will illuminate a restaurant menu board, bookcase, or shelving unit. Our Cafe shades will help transform your outdoor living area into a warm and intimate gathering space.



FEATURES + BENEFITS

- Metal RLM shades are spun from heavy duty aluminum.
- Dimmable with a dimmable bulb and compatible dimmer (not included).
- Polyester powder coat finish provides color retention and scratch resistance.
- White powder coat shade interior for maximum light output. Painted galvanized finish has painted galvanized shade interior.
- UL Listed for Wet Location.
- Warranty: Limited 1 Year.
- Made in USA.

SPECIFICATIONS

Product Dimensions:

Width 8 1/8", Height 15 1/8", Depth 12 3/4", Canopy Dia. 4 5/8"

Lamping:

Max Wattage: 100W per socket

Options:

- Finish: Slate Gray, Black, Forest Green, White Gloss, Sea Green, Painted Galvanized, Navy, Architectural Bronze, Light Blue, Barn Red
- Shade Size: 8 Inch, 12 Inch, 14 Inch, 16 Inch
- Accessories: Decorative Backplate Cover, Swivel, Weather-tight Glass and Cast Guard, Wire Grill, Integrated LED

Shipping:

At Montclair Light Works we proudly manufacture, assemble, and ship your lamp within 7-13 business days from our factory in Montclair CA.

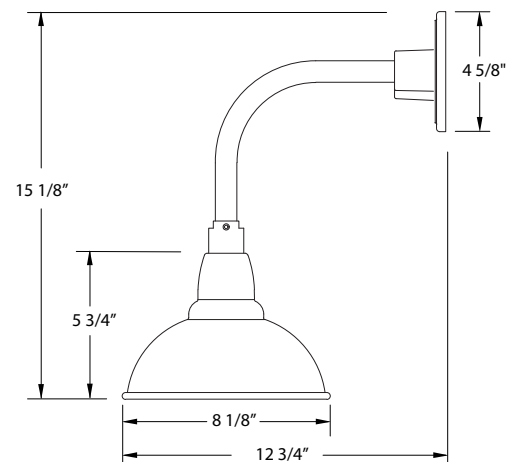

JOB/LOCATION

QUANTITY

DATE

NOTES