

	Press and display real height
	Press and display real height
	Press until 1 appears, release the button, it runs to corresponding height and displays current position.
	Press until 2 appears, release the button, it runs to corresponding height and displays current position.
	Press until 3 appears, release the button, it runs to corresponding height and displays current position.
	Press until 4 appears, release the button, it runs to corresponding height and displays current position.
	Save button, used to enter the save height function
Memory Position	After press , the interface flashes and set memory position, press until H1 appears, release button and it displays current height.
Reset	Long press for 5 seconds, display RES and press still, it goes down to the lowest and rebound certain height, reset finish and show basic height.

Protection mode (auto lock screen mode)	
Over-heating protection	Hot: it alarms when continuous working 2 minutes; clear automatically after resting 18 minutes.
Sensorless alarm	E10: It alarms when motor hall value cannot be inspected; clear it after press reset or re-power on.
Overload protection	E20: overload alarm when running up, clear automatically after 3 seconds; overload alarm when running down, clear it after press reset or re-power on.
Rebound protection	E02: it alarms in reversed compression when running; clear automatically after rebound 4cm; or press any button to clear when rebounding.
Overvoltage alarm	E32: it alarms when voltage is higher than limit value, clear automatically after voltage reduced to set value.
Undervoltage alarm	E31: it alarms when voltage is lower than limit value; clear automatically after voltage is higher than set value.
Step out alarm	E60: it alarms when height difference between left and right leg exceeds the set value; clear it after re-power on.
Breaking protection	It stops and enters protection state when motor lines or manual control lines are removed or disconnected accidentally; back to normal after reconnected and alarm cleared.
Conversion between metric and British system	Press button with 3 seconds, and the screen shows "M--" and flickers; Press M button again and functionality will be shown. Use and switch to () which will show the preset height data. Use to switch between options (). Press "M" button and keep 2 seconds to save current option.

DURONIC

www.duronic.com



EN-INSTRUCTION MANUAL
 ES-MANUAL DE INSTRUCCIONES
 FR-MANUEL D'INSTRUCTIONS
 DE-BENUTZERHANDBUCH
 IT -MANUALE DI ISTRUZIONI



TM23BK



TM23GY



TM23WE



Power Input
110V-240V



Speed
25 mm/s



Motion Noise
<55dB



Load Capability
220 lbs / 100 kg

CAUTION: DO NOT EXCEED
 MAXIMUM LISTED WEIGHT
 CAPACITY. SERIOUS INJURY
 OR PROPERTY DAMAGE MAY
 OCCUR!

► DISKONTRÓL

WARNING: FAILURE TO READ, THOROUGHLY UNDERSTAND, AND FOLLOW ALL INSTRUCTIONS CAN RESULT IN SERIOUS PERSONAL INJURY, DAMAGE TO PERSONAL PROPERTY, OR VOIDING OF FACTORY WARRANTY!

It is the responsibility of the installer to ensure all components are properly assembled and installed using the instructions provided. If you do not understand these instructions or have any questions or concerns, please contact customer service. Do not attempt to install or assemble this product if the product or hardware is damaged or missing. In the event that replacement parts or hardware are needed, please contact Customer Service. International customers requiring assistance should contact the Dealer from which they purchased the product.

► ESPAÑOL

ADVERTENCIA: NO LEER, ENTENDER CABALMENTE O SEGUIR TODAS LAS INSTRUCCIONES PUEDE DERIVAR EN LESIONES GRAVES, DAÑOS MATERIALES O LA NULIDAD DE LA GARANTÍA OTORGADA POR EL FABRICANTE.

Es responsabilidad del instalador comprobar que todos los componentes estén correctamente ensamblados e instalados según las instrucciones provistas. Si usted no entiende estas instrucciones o si tiene dudas o preguntas, comuníquese con Atención al Cliente.

No instale ni ensamble el producto si éste o las piezas suministradas presentaran daños o si faltara algún elemento. Si necesita repuestos o piezas, comuníquese con Atención al Cliente.

Si reside en otro país, comuníquese con la tienda donde compró el producto.

► FRANÇAIS

ATTENTION: SI VOUS NE LISEZ, NI NE COMPRENEZ, NI NE SUIVEZ SOIGNEUSEMENT TOUTES CES INSTRUCTIONS, IL POURRAIT S'ENSUIVRE DES BLESSURES GRAVES, DES DOMMAGES MATÉRIELS OU L'ANNULATION DE LA GARANTIE!

L'installateur est responsable de s'assurer de l'exactitude de l'assemblage et de l'installation de toutes les composantes, conformément aux instructions fournies. Si vous ne comprenez pas ces instructions ou pour toute question ou problème, veuillez contacter le service à la clientèle. Si le produit est endommagé ou que des fixations sont manquantes ou endommagées, n'installez pas le produit. Si vous avez besoin de pièces ou de quincaillerie de rechange, veuillez contacter le Service à la clientèle. Pour les clients internationaux, contactez le détaillant auprès duquel vous avez acheté le produit.

► DEUTSCH

WARNUNG: LESEN SIE DIESES HANDBUCH SORGFÄLTIG DURCH UND BEFOLGEN SIE DIE ANWEISUNGEN. EINE NICHTBEACHTUNG DERSELBEN KANN ZU SCHWEREN VERLETZUNGEN, SACHSCHADEN ODER ZUM ERLÖSCHEN DER WERKSGARANTIE FÜHREN!

Die Person, die die Montage vornimmt, hat sicherzustellen, dass alle Komponenten entsprechend den hierin bereitgestellten Anweisungen korrekt montiert und installiert werden. Sollten Sie diese Anweisungen nicht verstehen oder irgendwelche Fragen oder Zweifel diesbezüglich haben, kontaktieren Sie bitte unseren Kundendienst.

Versuchen Sie nicht, die Wandhalterung zu installieren oder montieren, wenn sie beschädigt ist oder ein Befestigungsteil fehlt. Bei Bedarf an Ersatz- oder Befestigungsteilen kontaktieren Sie bitte unseren Kundendienst. Kunden im Ausland sollten sich bei Bedarf an Hilfestellung an den Händler wenden, bei dem sie das Produkt erworben haben.

► ITALIANO

AVVERTENZA: LA MANCATA LETTURA, COMPRESIONE COMPLETA, OSSERVANZA DI TUTTE LE ISTRUZIONI PUÒ COMPORTARE GRAVI LESIONI PERSONALI, DANNI A COSE O INVALIDARE LA GARANZIA DI FABBRICA.

È responsabilità dell'installatore assicurare che tutti i componenti siano assemblati e installati correttamente, mediante l'utilizzo delle istruzioni a corredo. Nel caso in cui sorgessero incomprensioni in merito alle presenti istruzioni oppure per domande o problemi, si prega di contattare il servizio clienti al. Non tentare di installare o assemblare il prodotto se il prodotto stesso o i componenti risultano danneggiati o mancanti. Nel caso in cui fosse necessario sostituire parti o componenti, si prega di contattare il Servizio Clienti al

I Clienti internazionali che necessitano di assistenza possono rivolgersi al Rivenditore presso cui è stato acquistato il prodotto.

7

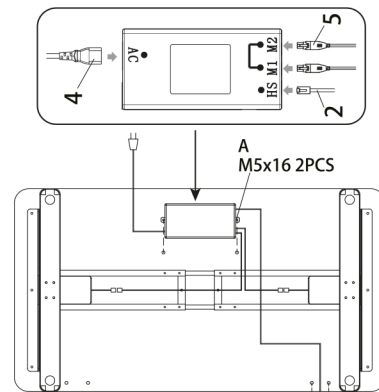

Rip the protective film off before the monitor is installed.
A M5x16 2PCS

Mount the control box(8) under desktop(1) with screws (A).
Use the screws (A) to install the controller panel(2) under the desktop (the left and right sides of the desktop can be chosen)

8

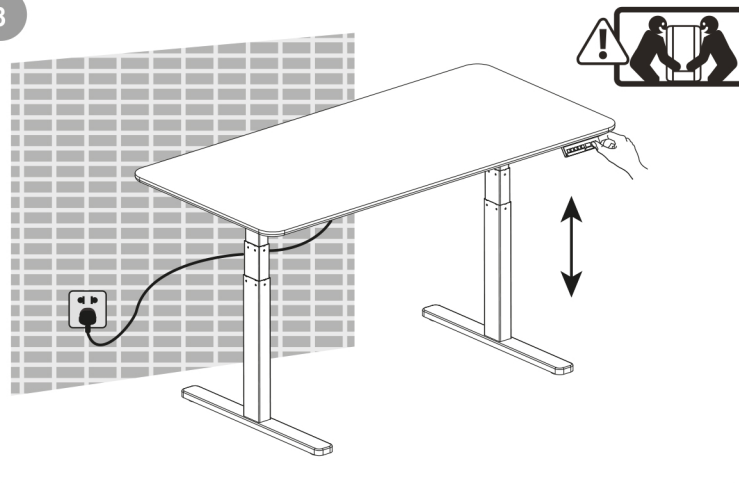

Turn the table over and turn on the power test.

5

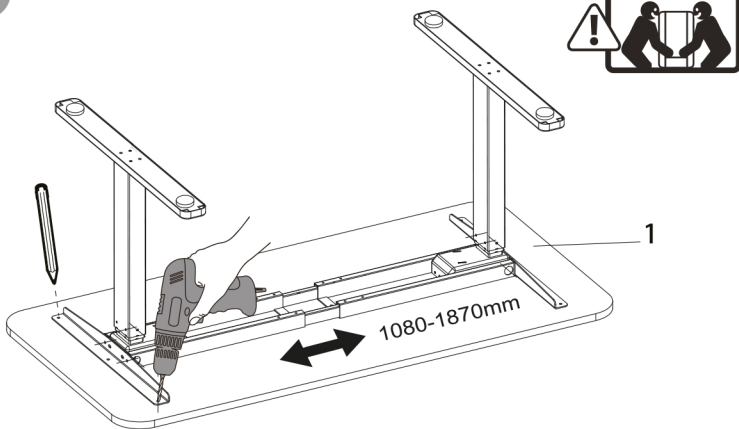

Adjust the distance according to the size of desktop.

6

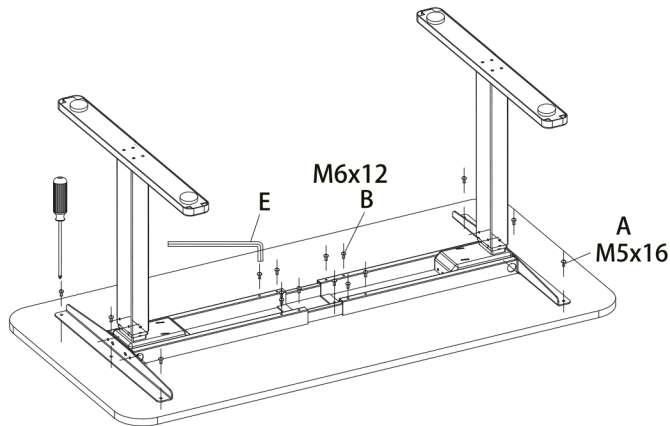

Fix legs on the back of desktop with screw (A).
Fix the frame with screw (B).

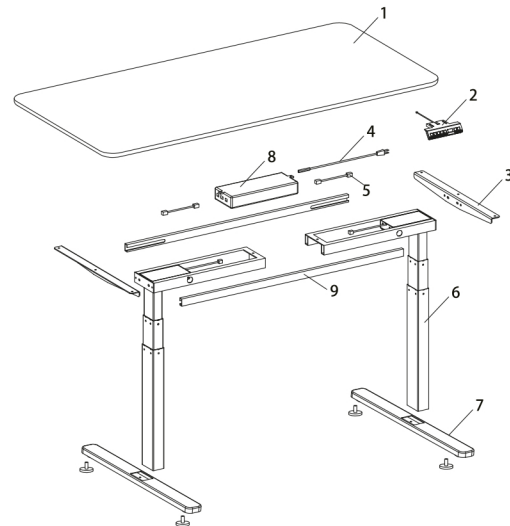

Desk Parts

1.	Desktop(Optional) (not included)		1pc
2.	Controller panel		1pc
3.	Side plates		2pcs
4.	Power cord		1pc
5.	Connection lines		2pcs
6.	Table legs		2pcs
7.	Feet		2pcs
8.	Controller box		1pc
9.	Connecting rods		2pcs

Screws/Fasteners (bag)

A	M5×16 screws (2pcs extra)		14pcs
B	M6×12 screws (2pcs extra)		18pcs
C	M6×16 screws		8pcs
D	Foot pads		4pcs
E	S=4mm		1pc
F	Adhesive clip		5pcs

1

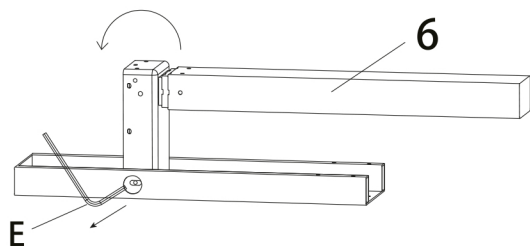

Loosen the screw but don't unscrew it. Then open the leg.

2

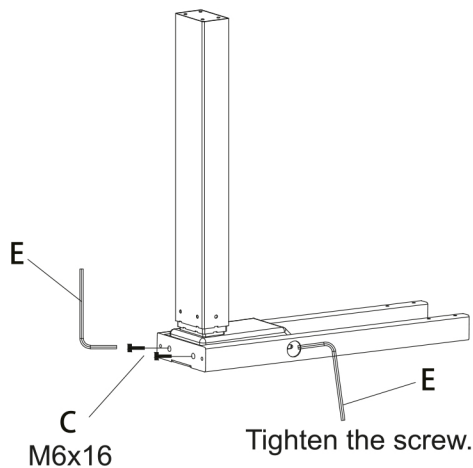

Tighten the screw.

3

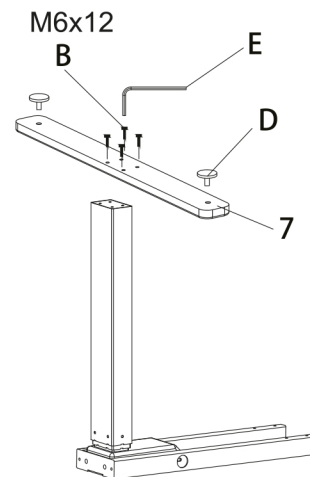

Screw foot pads (D) into the feet (7), then attach the feet (7) to the leg using screws (B) and tighten with the wrench (E).

4

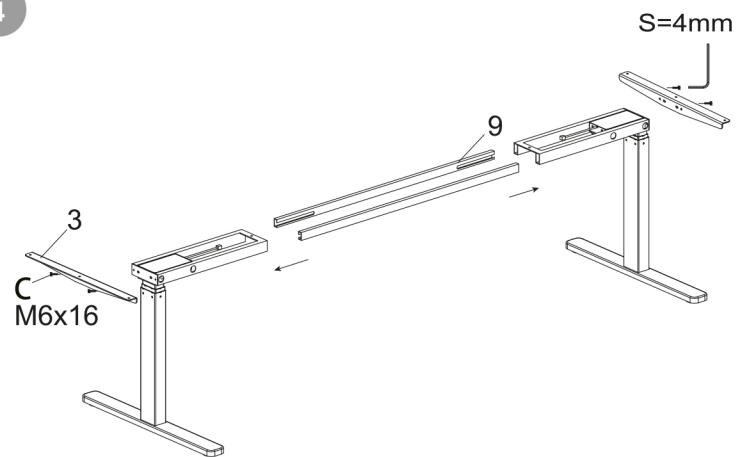

Install the side plate (3) and use the wrench (E) to lock the screw (C). Insert the connecting rod (9) into the frame.