



## RCD6200 Boombox

PLEASE READ ALL THE INSTRUCTIONS BEFORE USE



[duristic.com](http://duristic.com)



[duristic](https://www.youtube.com/duristic)



[@duristicmedia](https://www.instagram.com/duristicmedia)



[Duristic](https://www.facebook.com/Duristic)



[@duristicmedia](https://www.twitter.com/duristicmedia)



## Contents

<b>English Manual</b>	<b>5</b>
<b>Manuel d'utilisation en français</b>	<b>11</b>
<b>Gebrauchsanleitung auf Deutsch</b>	<b>17</b>
<b>Manual de Instrucciones en Español</b>	<b>23</b>
<b>Manuale D'istruzioni In Italiano</b>	<b>29</b>



**English Manual**

## Safety Information



The lightning flash and arrowhead within the triangle is a warning sign alerting you of “dangerous voltage” inside the product.



**WARNING:** To reduce the risk of an electric shock, do not remove the cover (or back). No user-serviceable parts inside. Refer servicing to qualified service personnel.



**CAUTION:** The exclamation point within the triangle is a warning sign, alerting you of important instructions accompanying the product.



**CAUTION:** To reduce the risk of fire or electric shock or damage, do not expose this appliance/ apparatus to dripping or splashing liquids. Also, make sure that no objects filled with liquids are placed on the appliance/ apparatus.

**Note:** The rating label for this product is located on the bottom of the unit.

**Caution:** Grounding or polarization: precautions should be taken so that the wider blade of the ac plug (of ac-adaptor) must match the slot in the outlet “wall socket”. (Only if your ac plug is polarized)

**Note:** Caution symbols are printed on the rear of the unit or accessories. Please refer to the instruction manual.

**Caution:** Danger of explosion if battery is incorrectly replaced. Replace only with the same or equivalent type. Battery replacement must only be done by a qualified professional technician.

- Keep minimum distance (5cm) around the apparatus for sufficient ventilation.
- The ventilation should not be impeded or covered with items such as newspaper, table-cloths, curtains etc.
- No naked flame sources such as lit candles should be placed on the apparatus.
- This appliance/ apparatus is intended domestic use only.

**Caution:** Invisible laser radiation is present when the appliance is open, avoid exposure to beam.

## Parts & Assembly

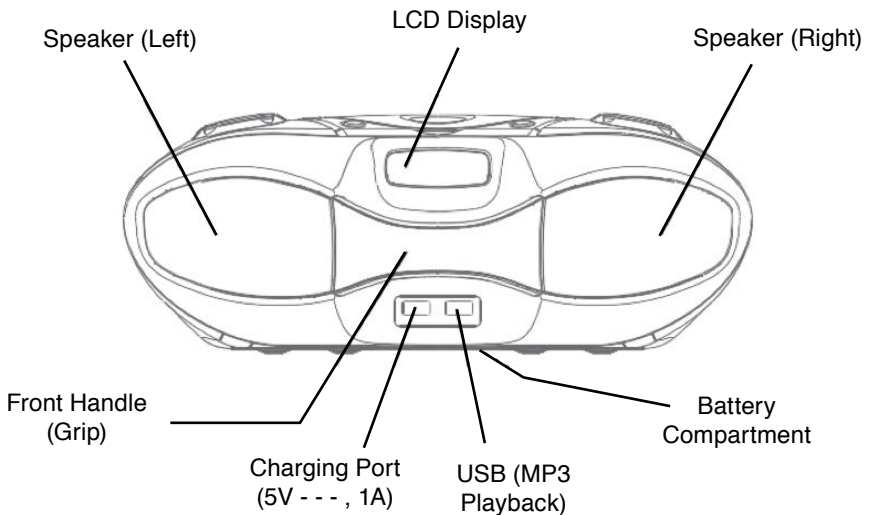
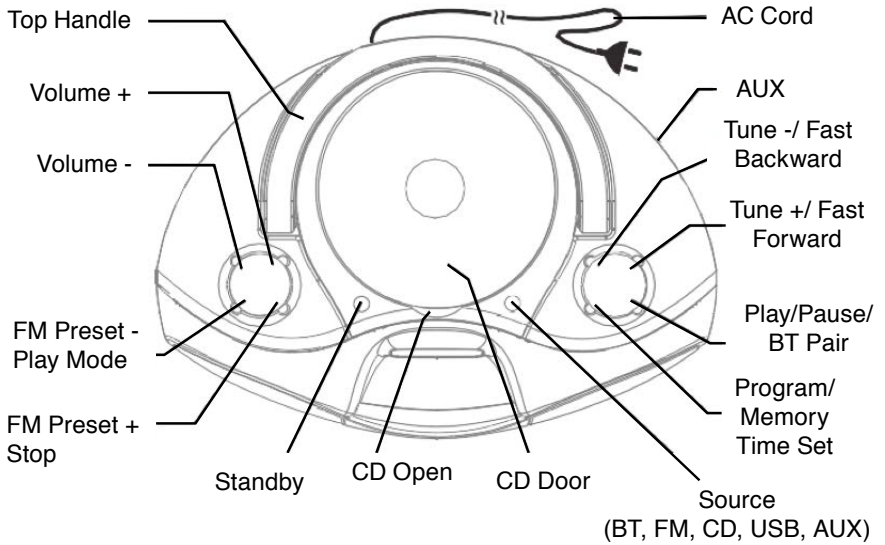

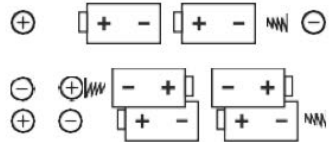
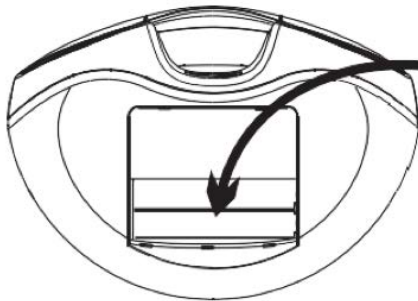
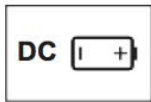

**1.5V x 6 PCS.**

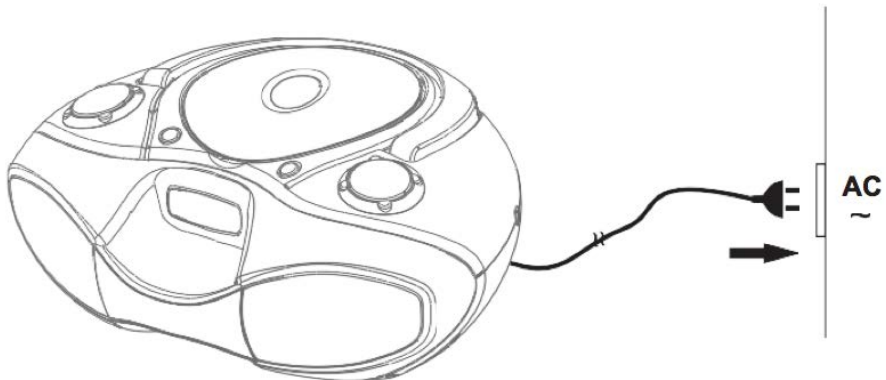





① "STAND-BY"



" ⌚ SET "



2 Seconds

Press

LCD:

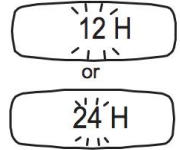

② 12H or 24H?

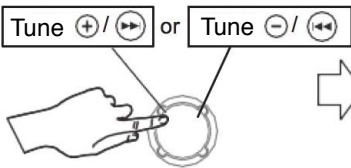

LCD:

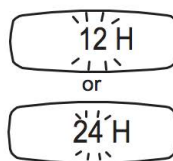

**OK!**



" ⌚ SET "

③ Hour Setting

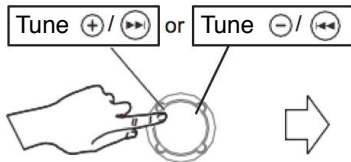

**OK!**

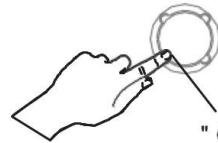

" ⌚ SET "

④ Minute Setting

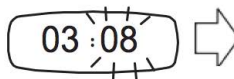
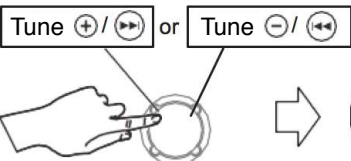

**OK!**



" ⌚ SET "

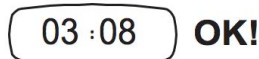



①

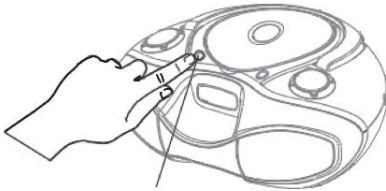

ON!



BT "ON" !

②

SOURCE = BT

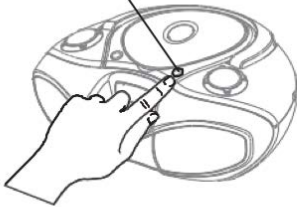

<b>BT</b>	Slow	=			Searching
<b>BT</b>	Fast	=	→		← Pairing (Code:0000)
<b>BT</b>	On	=			Connected

In order to avoid interference, please de-activate Wi-Fi on your device (smartphone, tablet, etc.) when playing music using Bluetooth®

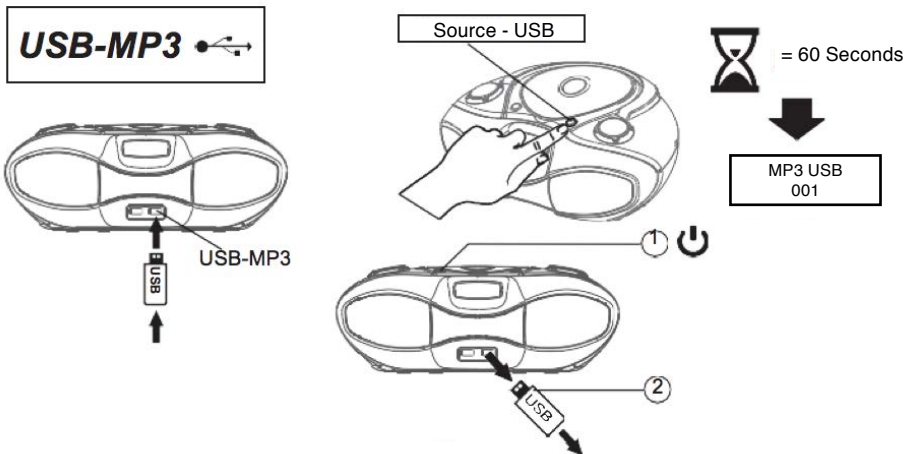
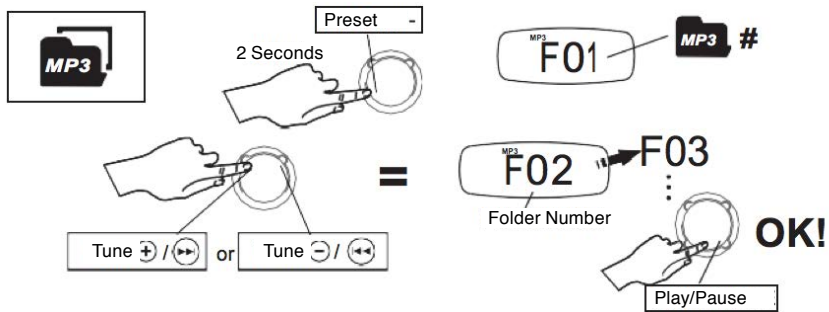
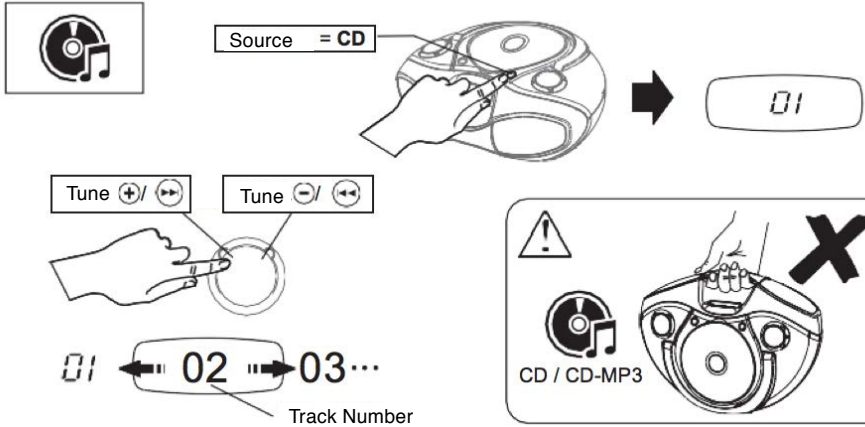

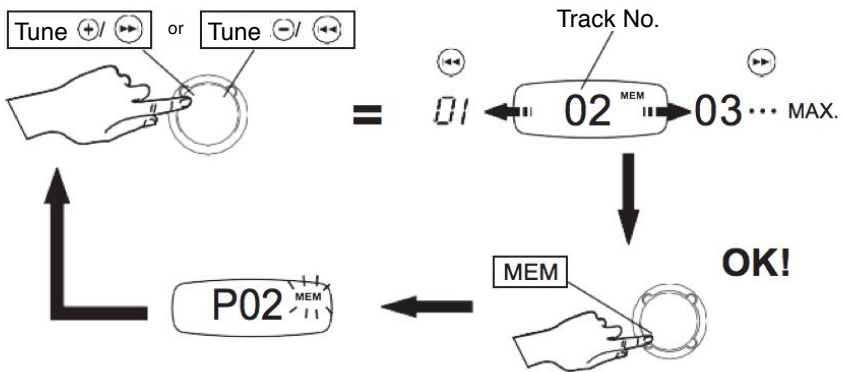
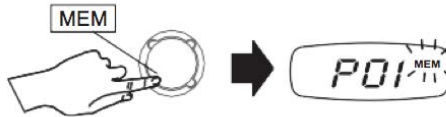
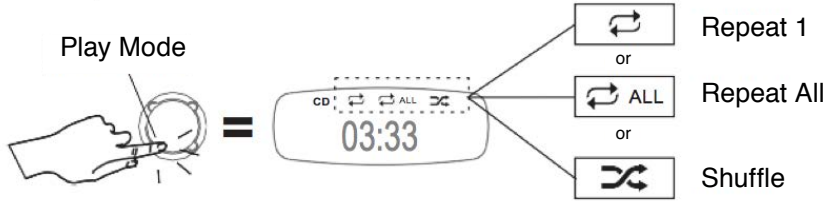
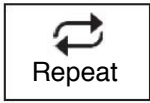

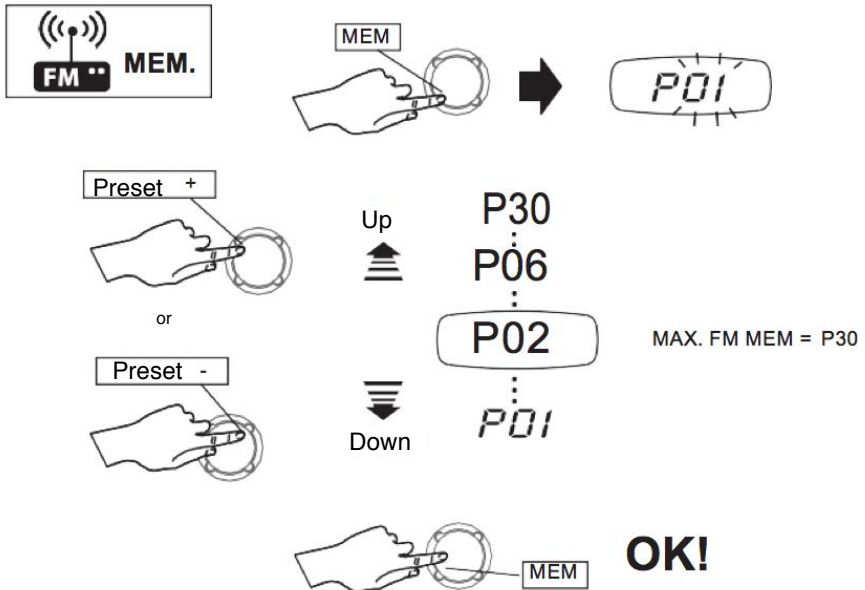
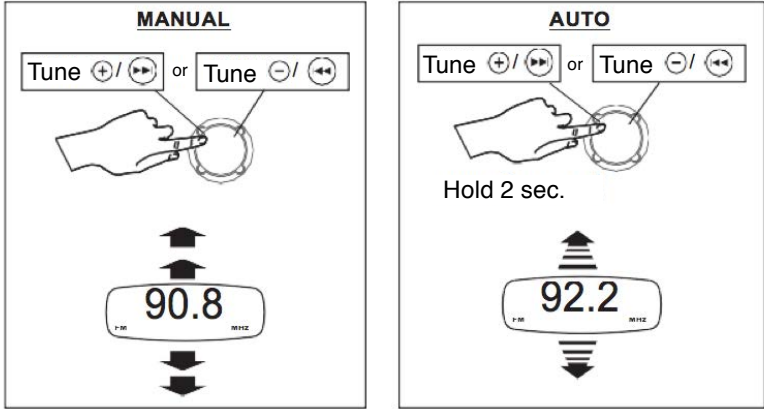
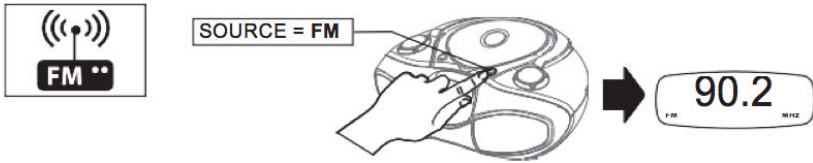

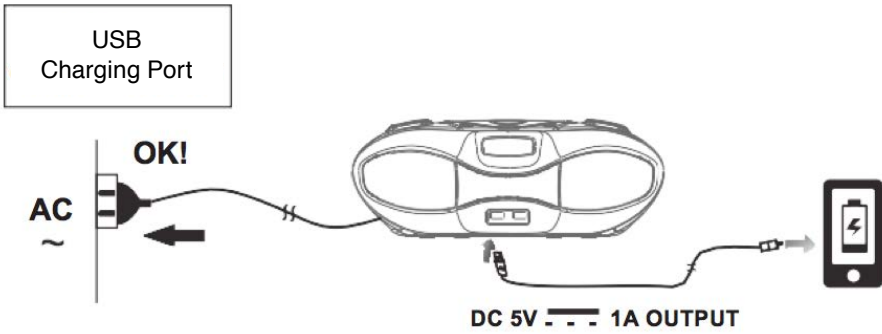
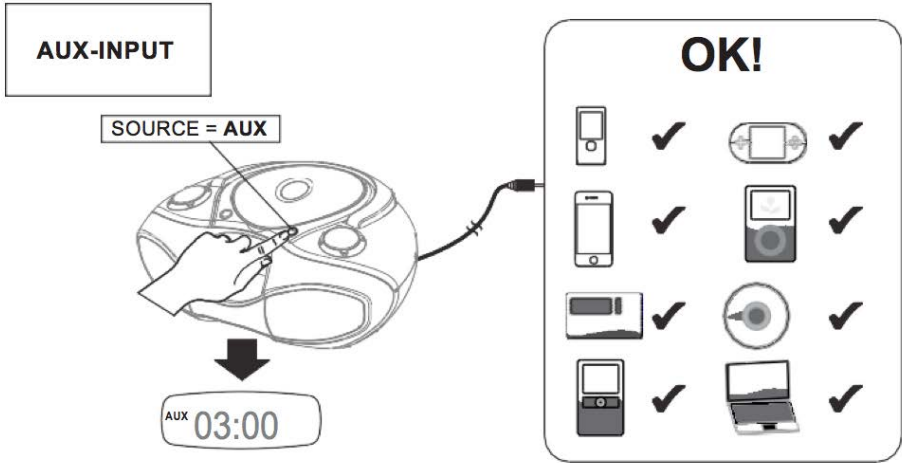

Power Supply: AC100-240V~50/60Hz  
 DC 9V - - - - (6 x C-CELL/ UM-2/ LR14 SIZE)  
 (BATTERIES NOT INCLUDED)

Recharge Power: USB 5V - - - - 1A  
 Frequency: FM 87.5 - 108 MHz  
 Wireless Range (BT): 10M (30 Ft.)  
 FM Station Memory: 30 Stations  
 CD Program Memory: 20 Songs  
 MP3 Program Memory: 99 Songs

# Warranty

1 Year Guarantee from Shine-Mart Ltd, Trademark owners of Duronic Products.

NOTE: THESE STATEMENTS DO NOT AFFECT YOUR STATUTORY RIGHTS AS A CONSUMER

This product has been manufactured under the strictest of quality control procedures, and using the highest quality of materials, to ensure excellent performance and reliability. It will give very good and long lasting service, provided it is properly used and maintained. The product is guaranteed for 1 years from the date of original purchase. If any defect arises due to a faulty materials or poor workmanship, the faulty product must be returned to the original place of purchase. Refund or replacement is at the discretion of that company. Duronic Products are offered with a 1 year guarantee under the following conditions:

1. The product must be returned to the retailer with original proof of purchase.
2. The product must be installed and used in accordance with the instructions contained in this operating manual.
3. It must be used only for domestic purposes.
4. It does not cover wear and tear, malicious damage, misuse, neglect, inexpert repairs or consumable parts.
5. Shine-Mart Ltd has no responsibilities for accidental or consequential loss or damage.
6. Shine-Mart Ltd are not liable to carry out any type of servicing work, under the guarantee
7. Valid in the UK only



This product is fitted with CE:1363 plug and fuse  
Imported by Shine-Mart Ltd, RM3 8SB



Information on waste Disposal for Consumers of  
Electrical & Electronic Equipment.

This mark on a product and/or accompanying documents indicates that when it is to be disposed of, it must be treated as Waste Electrical & Electronic Equipment, (WEEE).

Any WEEE marked products must not be mixed with general household waste, but kept separate for the treatment, recovery and recycling of the materials used. For proper treatment, recovery and recycling; please take all WEEE marked waste to your Local Authority Civic waste site, where it will be accepted free of charge.

If customers dispose of Waste Electrical & Electronic Equipment correctly, they will be helping to save valuable resources and preventing any potential negative effects upon human health and the environment, of any hazardous materials that the waste may contain.

## Follow Us



[duronic.com](http://duronic.com)



[duronic](https://www.youtube.com/channel/UCduronic)



[@duronicmedia](https://www.instagram.com/duronicmedia)



[Duronic](https://www.facebook.com/duronic)



[@duronicmedia](https://twitter.com/duronicmedia)

**Manuel d'utilisation en français**



## Safety Information



The lightning flash and arrowhead within the triangle is a warning sign alerting you of “dangerous voltage” inside the product.



**WARNING:** To reduce the risk of an electric shock, do not remove the cover (or back). No user-serviceable parts inside. Refer servicing to qualified service personnel.



**CAUTION:** The exclamation point within the triangle is a warning sign, alerting you of important instructions accompanying the product.



**CAUTION:** To reduce the risk of fire or electric shock or damage, do not expose this appliance/ apparatus to dripping or splashing liquids. Also, make sure that no objects filled with liquids are placed on the appliance/ apparatus.

**Note:** The rating label for this product is located on the bottom of the unit.

**Caution:** Grounding or polarization: precautions should be taken so that the wider blade of the ac plug (of ac-adaptor) must match the slot in the outlet “wall socket”. (Only if your ac plug is polarized)

**Note:** Caution symbols are printed on the rear of the unit or accessories. Please refer to the instruction manual.

**Caution:** Danger of explosion if battery is incorrectly replaced. Replace only with the same or equivalent type. Battery replacement must only be done by a qualified professional technician.

- Keep minimum distance (5cm) around the apparatus for sufficient ventilation.
- The ventilation should not be impeded or covered with items such as newspaper, table-cloths, curtains etc.
- No naked flame sources such as lit candles should be placed on the apparatus.
- This appliance/ apparatus is intended domestic use only.

**Caution:** Invisible laser radiation is present when the appliance is open, avoid exposure to beam.

## Parts & Assembly

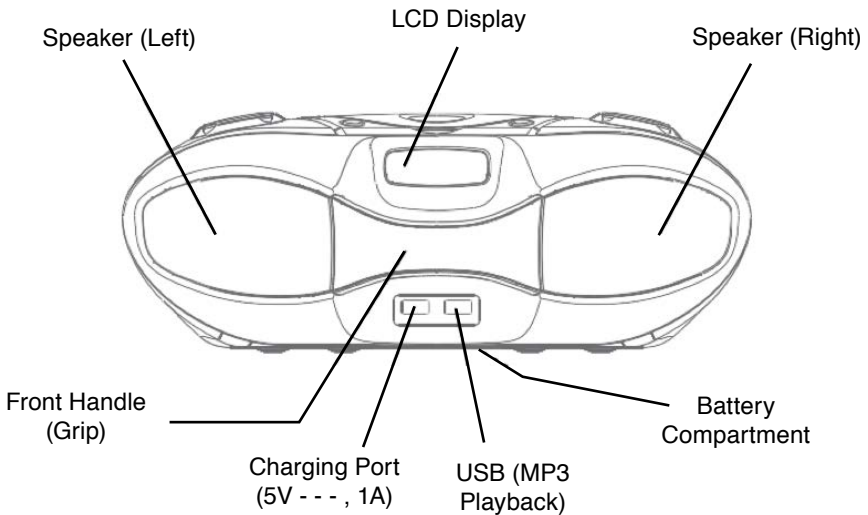
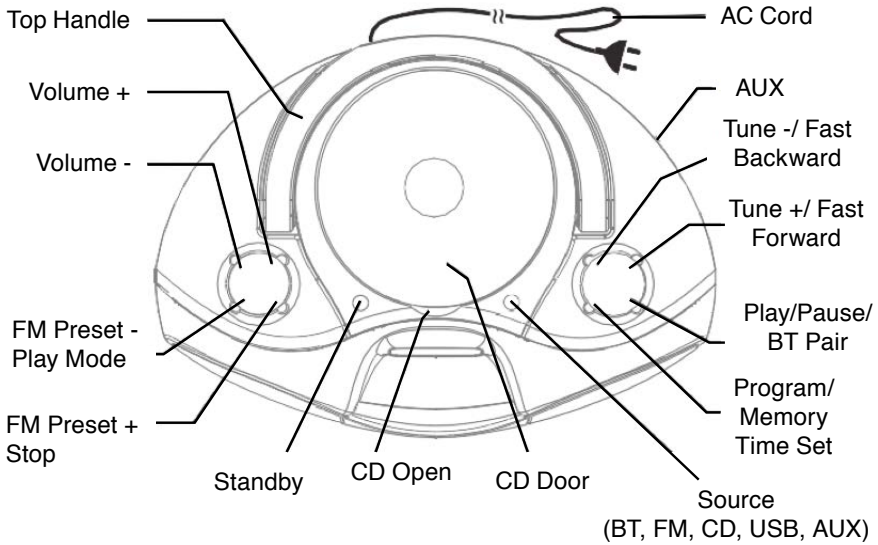

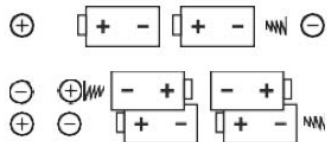
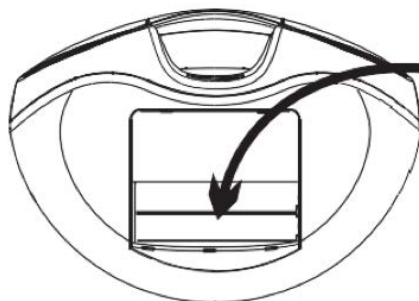

**1.5V x 6 PCS.**

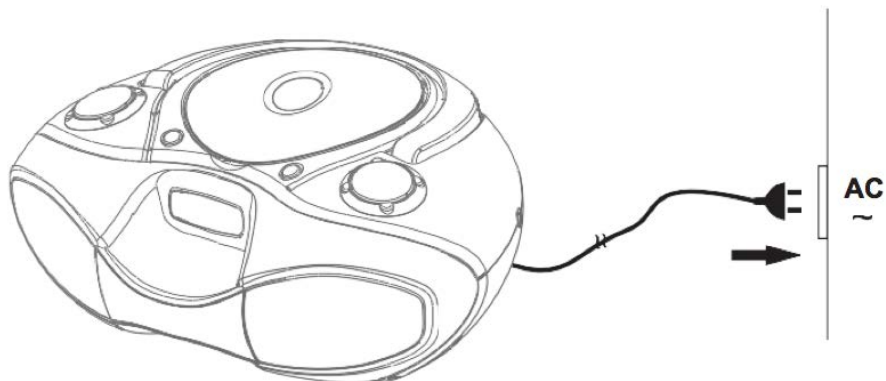



① "STAND-BY"

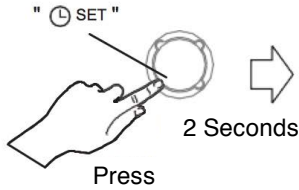

LCD:

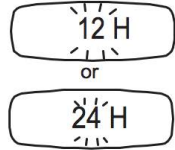

② 12H or 24H?

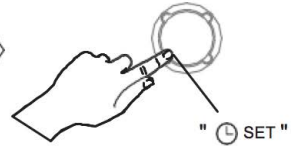
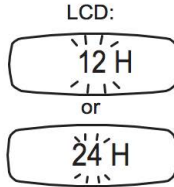
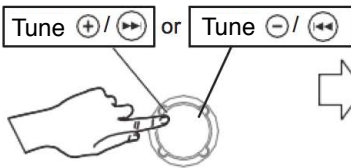

OK!

③ Hour Setting

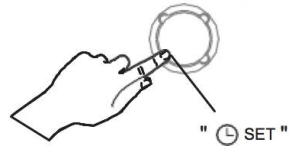
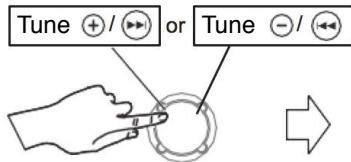

OK!

④ Minute Setting

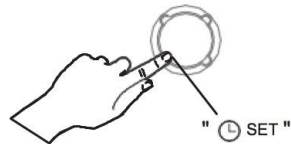
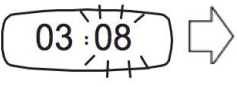
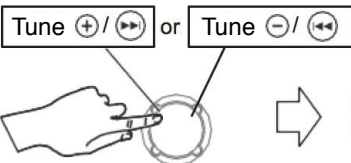

OK!

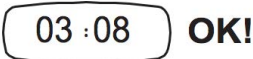



①

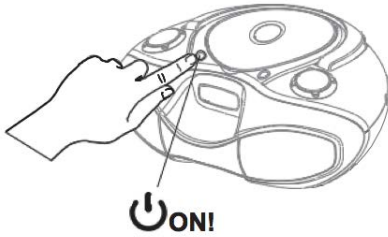

ON!



BT "ON" !

②

SOURCE = BT

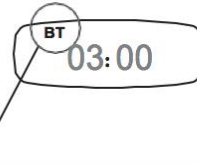
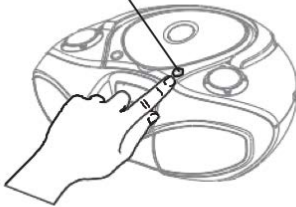

⋮ BT ⋮	Slow =			Searching
⋮ BT ⋮	Fast =	→		← Pairing (Code:0000)
BT	On =			Connected

In order to avoid interference, please de-activate Wi-Fi on your device (smartphone, tablet, etc.) when playing music using Bluetooth®

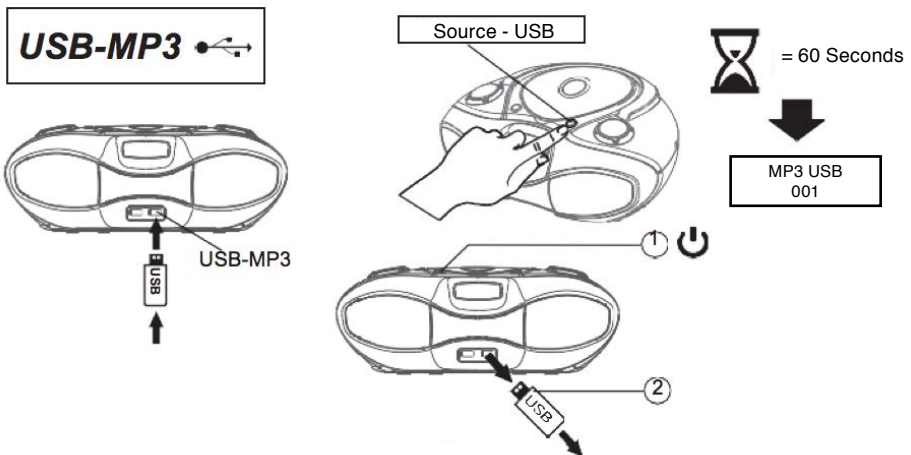
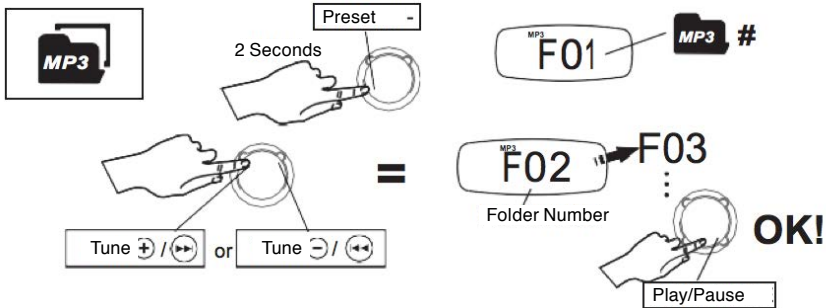
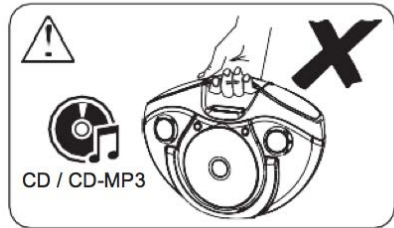
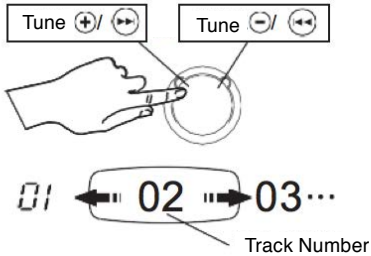
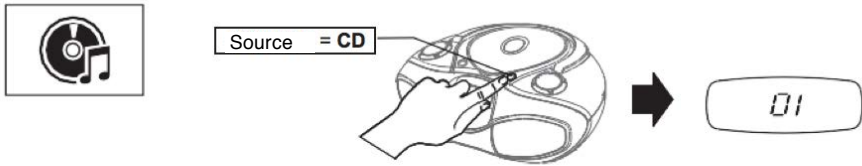

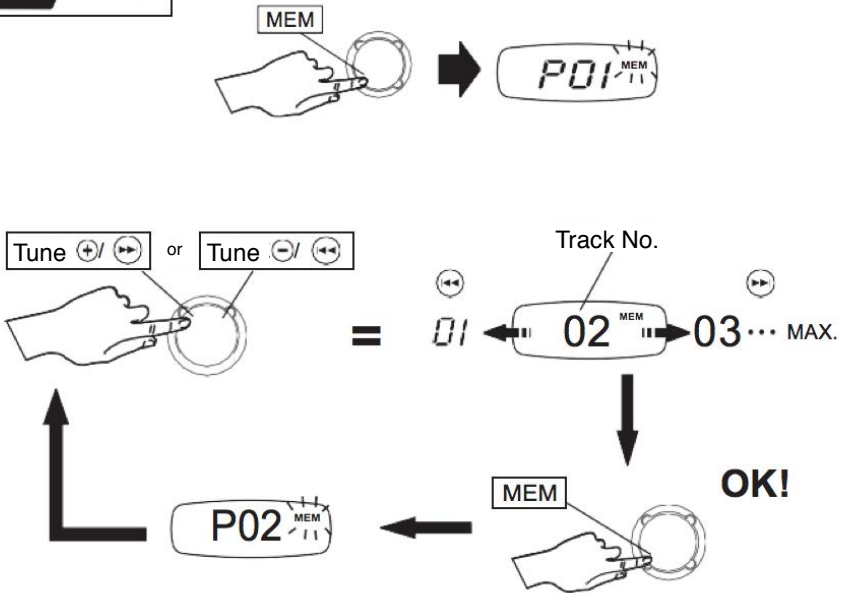
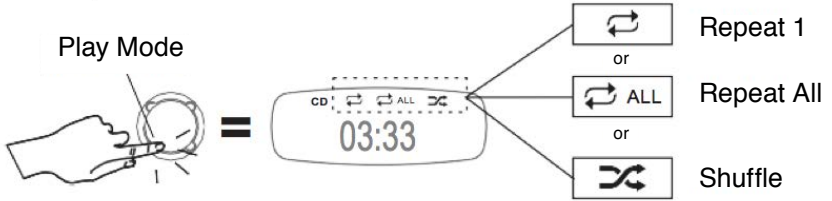
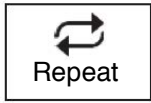



SOURCE = FM

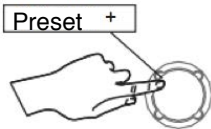
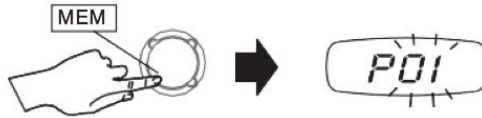
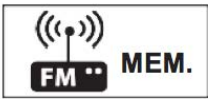
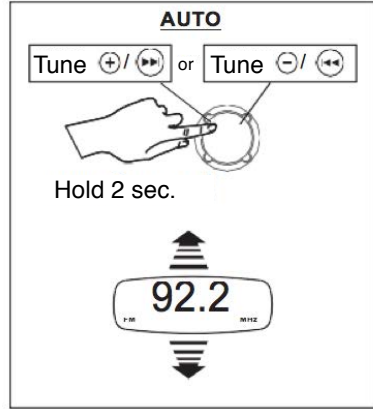
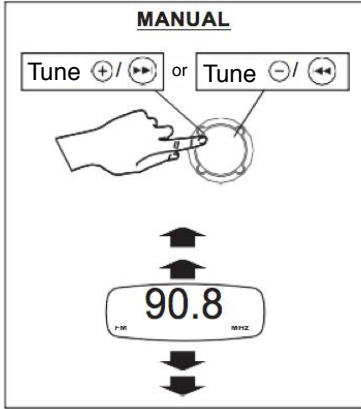
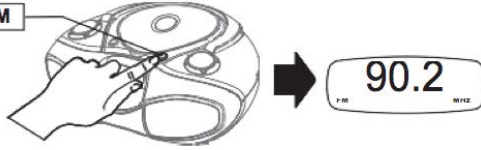

or

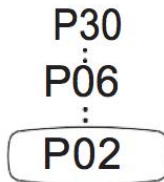
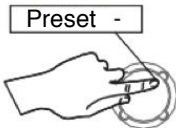

MAX. FM MEM = P30



**OK!**



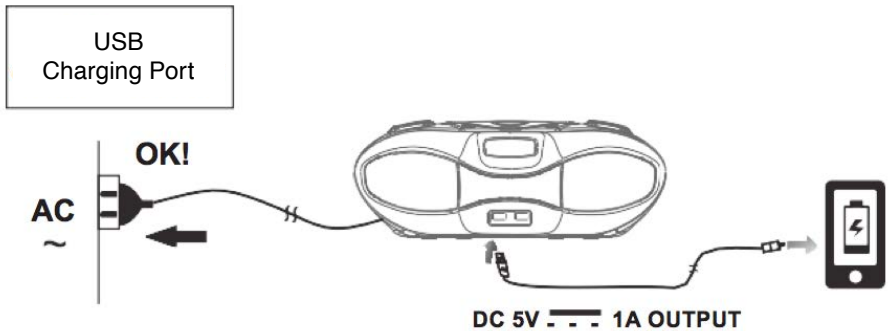
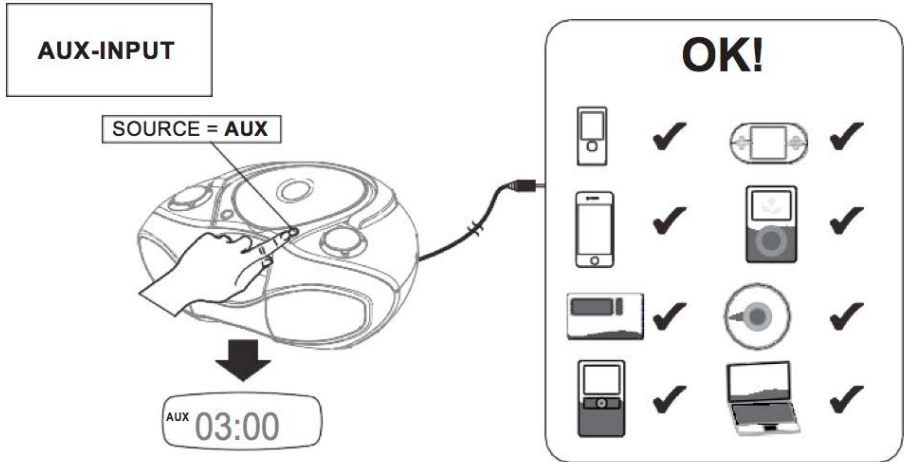

Power Supply: AC100-240V~50/60Hz  
 DC 9V --- (6 x C-CELL/ UM-2/ LR14 SIZE)  
 (BATTERIES NOT INCLUDED)

Recharge Power: USB 5V --- 1A  
 Frequency: FM 87.5 - 108 MHz  
 Wireless Range (BT): 10M (30 Ft.)  
 FM Station Memory: 30 Stations  
 CD Program Memory: 20 Songs  
 MP3 Program Memory: 99 Songs

# Garantie

## Garantie et service après-vente

1 an de garantie de la part de Shine-Mart Ltd, propriétaire de la marque Duronic.

NOTE : CES DÉCLARATIONS N'AFECTENT EN RIEN VOTRE DROIT STATUTAIRE EN TANT QUE CONSOMMATEUR

Ce produit a été produit en suivant les procédures de contrôle de qualité les plus strictes en utilisant des matériaux de qualité pour assurer une excellente durabilité et performance.

Cette centrifugeuse vous offrira de longues années de service tant que vous utilisez correctement cette machine et suivez les instructions de maintenance contenues dans ce manuel. Ce produit est garanti pour 1 an à partir de la date originelle d'achat. Si ce produit était endommagé en raison d'un problème électrique ou d'une fabrication imparfaite, le produit défectueux peut être remplacé au vendeur à la discrétion de la marque sous conditions:

1. Le produit doit être retourné avec la preuve originale d'achat.
2. Le produit doit être installé et utilisé en accord avec les instructions contenues dans ce manuel d'utilisation.
3. Le produit doit être réservé à un usage privé.
4. La garantie ne protège pas contre les dommages dus à l'usure normale, l'utilisation malveillante, la mauvaise utilisation, la négligence, les réparations conduites par des non-experts ainsi que les pièces consommables.
5. Shine-Mart Ltd ne porte pas de responsabilité pour tout dommage ou perte accidentel ou conséquent causé par ce produit.
6. Shine-Mart Ltd se dégage de toute responsabilité en matière de réparation durant la période de garantie.
7. Valide dans toute l'Union Européenne.



Ce produit est fourni avec une prise européenne et un fusible de 3 ampères.  
Importé par Shine-Mart Ltd, RM3 8SB.



Ce symbole apparaît sur le produit et/ou les documents accompagnant ce produit pour indiquer que pour procéder à la destruction de ce produit, celui-ci doit être traité comme un déchet électrique et électronique (WEEE). Les produits marqués WEEE ne doivent être mélangés avec les déchets ménagers et doivent être séparés pour traitement et recyclage des composants. Afin de traiter et recycler ce produit, veuillez déposer tous les composants marqués WEEE au site de recyclage le plus proche où ce produit sera repris gratuitement. Si les clients jettent les déchets électriques et électroniques WEEE correctement, ce geste aidera la préservation de ressources précieuses et prévient les potentiels effets négatifs que ces composants ou tout autre composant dangereux ont sur la santé humaine et l'environnement.

suivez nous



[www.duronic.com](http://www.duronic.com)



[@duronic\\_france](https://www.instagram.com/duronic_france)



[Duronic France](https://www.facebook.com/Duronic France)



[@Duronic\\_France](https://twitter.com/Duronic_France)

**Gebrauchsanleitung auf Deutsch**

## Safety Information



The lightning flash and arrowhead within the triangle is a warning sign alerting you of “dangerous voltage” inside the product.



**WARNING:** To reduce the risk of an electric shock, do not remove the cover (or back). No user-serviceable parts inside. Refer servicing to qualified service personnel.



**CAUTION:** The exclamation point within the triangle is a warning sign, alerting you of important instructions accompanying the product.



**CAUTION:** To reduce the risk of fire or electric shock or damage, do not expose this appliance/ apparatus to dripping or splashing liquids. Also, make sure that no objects filled with liquids are placed on the appliance/ apparatus.

**Note:** The rating label for this product is located on the bottom of the unit.

**Caution:** Grounding or polarization: precautions should be taken so that the wider blade of the ac plug (of ac-adaptor) must match the slot in the outlet “wall socket”. (Only if your ac plug is polarized)

**Note:** Caution symbols are printed on the rear of the unit or accessories. Please refer to the instruction manual.

**Caution:** Danger of explosion if battery is incorrectly replaced. Replace only with the same or equivalent type. Battery replacement must only be done by a qualified professional technician.

- Keep minimum distance (5cm) around the apparatus for sufficient ventilation.
- The ventilation should not be impeded or covered with items such as newspaper, table-cloths, curtains etc.
- No naked flame sources such as lit candles should be placed on the apparatus.
- This appliance/ apparatus is intended domestic use only.

**Caution:** Invisible laser radiation is present when the appliance is open, avoid exposure to beam.

## Parts & Assembly

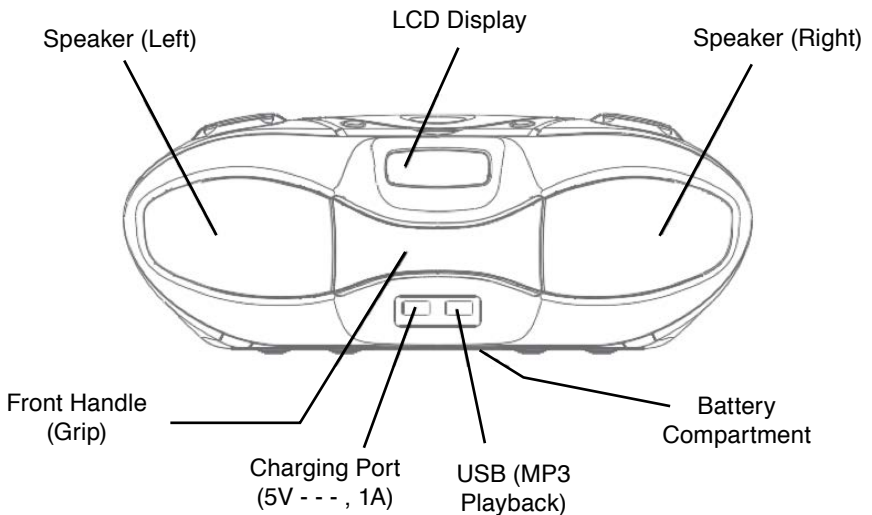
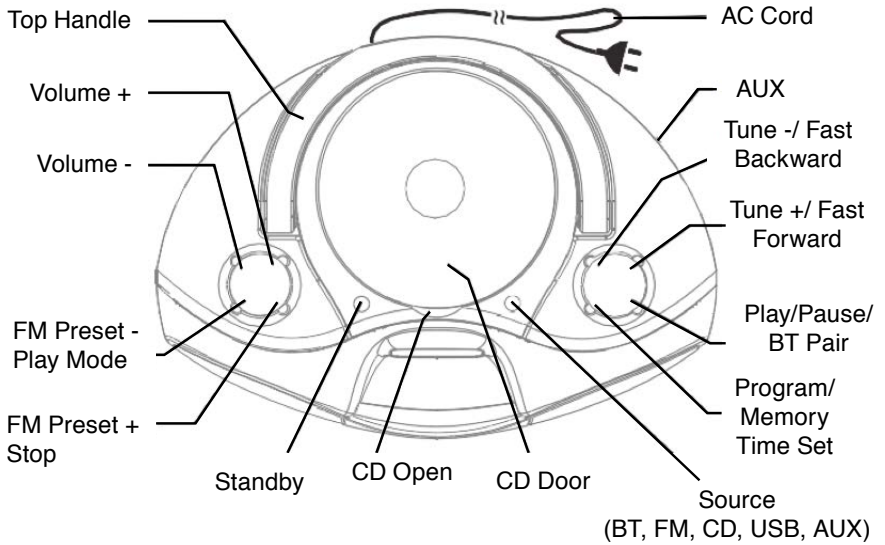

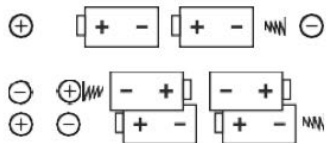
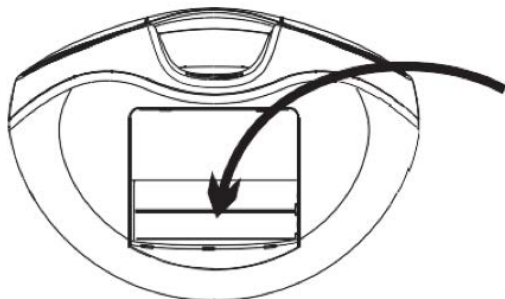
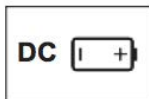

**1.5V x 6 PCS.**

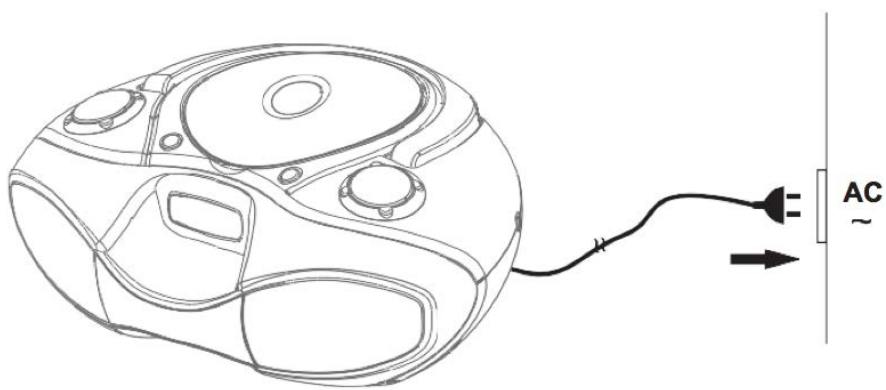



① "STAND-BY"



" ⌚ SET "



2 Seconds

Press

LCD:

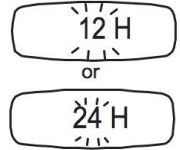

② 12H or 24H?

Tune + / >> or Tune - / <<



LCD:

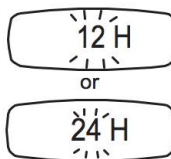

OK!

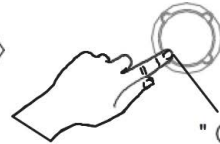

" ⌚ SET "

③ Hour Setting

Tune + / >> or Tune - / <<

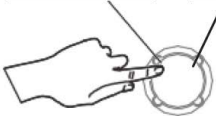

OK!



" ⌚ SET "

④ Minute Setting

Tune + / >> or Tune - / <<

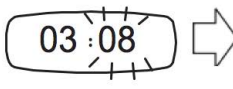

OK!



" ⌚ SET "

03 : 08 OK!



①

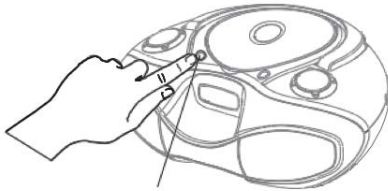

ON!



BT "ON" !

②

SOURCE = BT

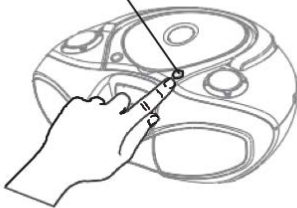

BT	Slow	=			Searching
BT	Fast	=	→		← Pairing (Code:0000)
BT	On	=			Connected

In order to avoid interference, please de-activate Wi-Fi on your device (smartphone, tablet, etc.) when playing music using Bluetooth®



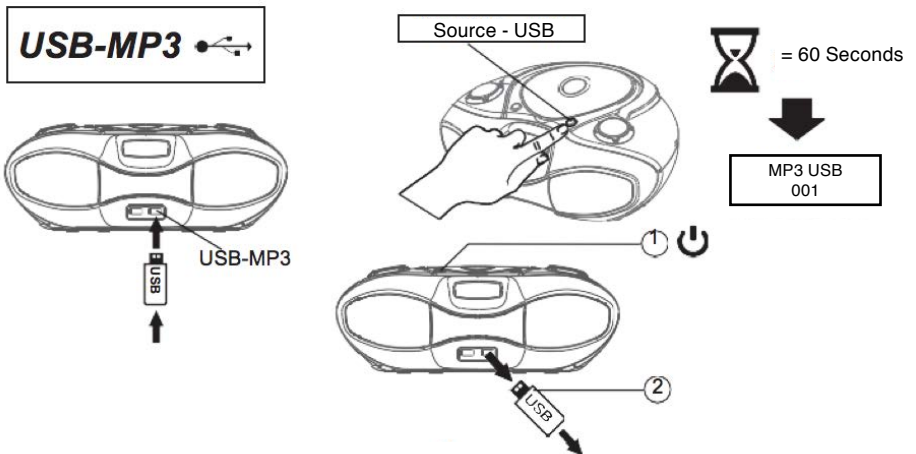
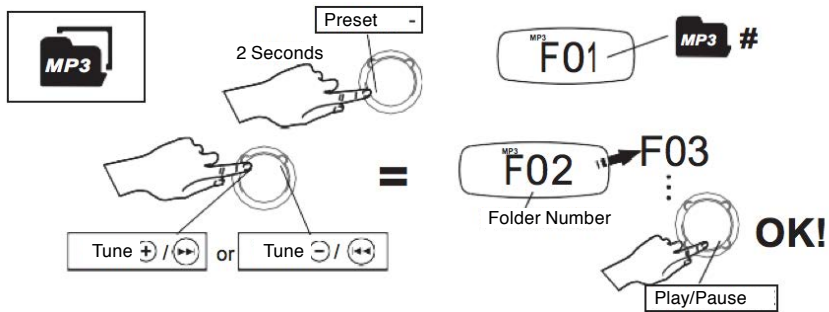
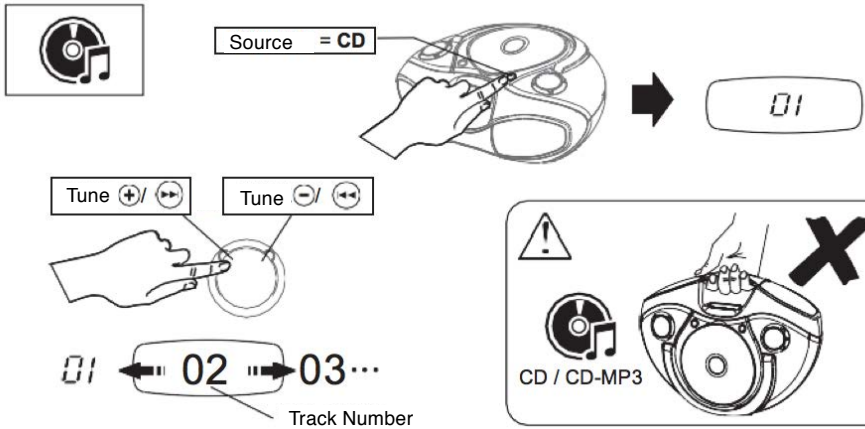

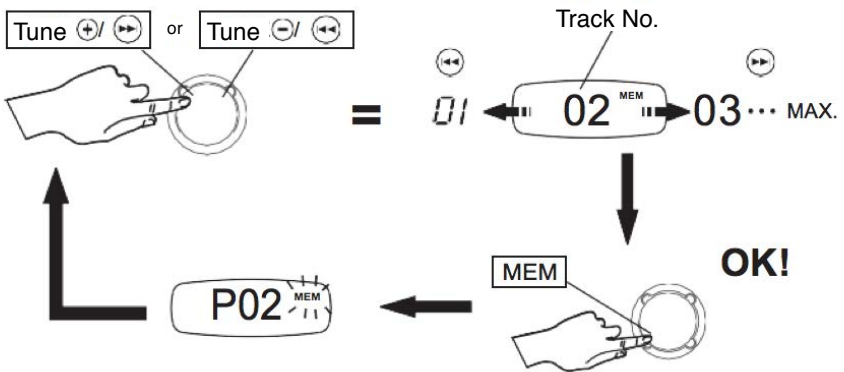
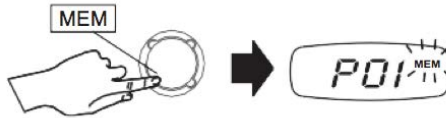
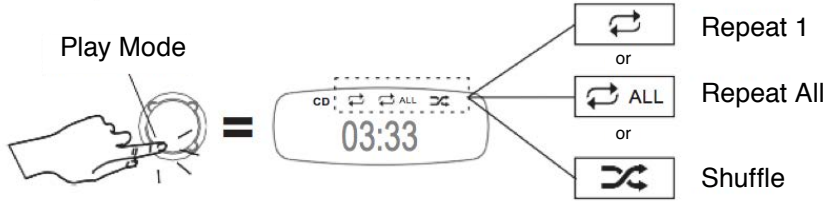
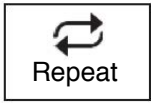

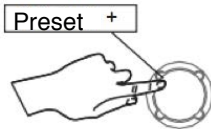
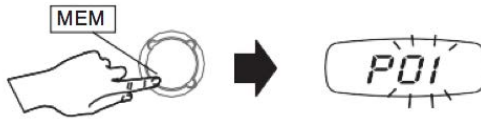
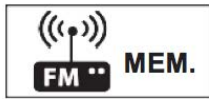
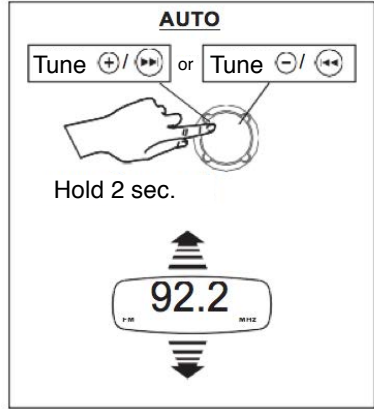
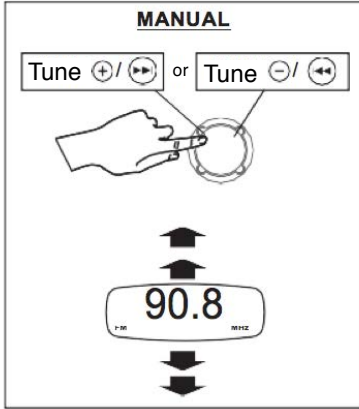
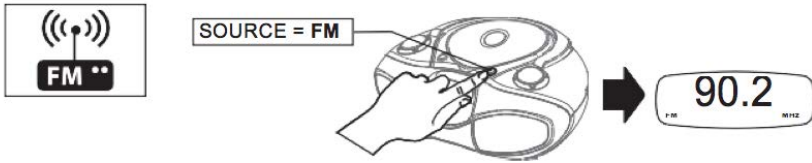

or

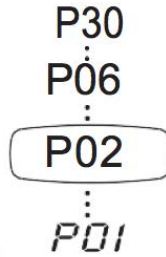
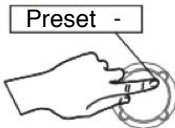

MAX. FM MEM = P30



OK!

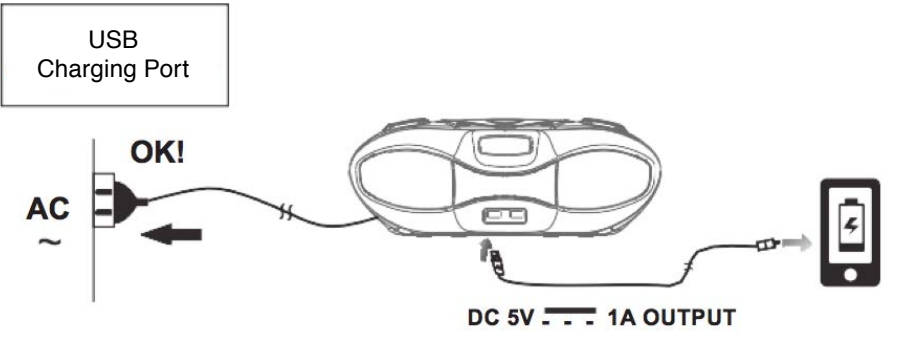
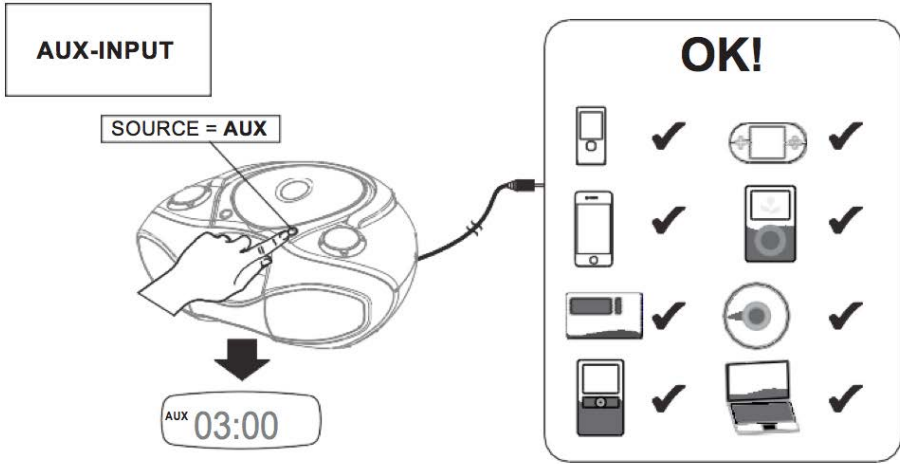

Power Supply: AC100-240V~50/60Hz  
 DC 9V (6 x C-CELL/ UM-2/ LR14 SIZE)  
 (BATTERIES NOT INCLUDED)

Recharge Power: USB 5V 1A  
 Frequency: FM 87.5 - 108 MHz  
 Wireless Range (BT): 10M (30 Ft.)  
 FM Station Memory: 30 Stations  
 CD Program Memory: 20 Songs  
 MP3 Program Memory: 99 Songs

# Gewährleistung

1 Jahr Gewährleistung von Shine-Mart Ltd, der Markeninhaber von Duronic Produkte.

ZUR BEACHTUNG : DIESE BEDINGUNGEN HABEN KEINE BEEINFLUSSUNG AUF IHRE GESETZLICHE RECHTE ALS VERBRAUCHER

Dieses Produkt wurde unter strengen Qualitätskontrollen hergestellt, und wurde aus hochwertigen Werkstoffen produziert, um ausgezeichnete Leistung und Zuverlässigkeit zu gewährleisten. Sofern das Produkt korrekt benutzt und gewartet wird, wird eine langlebige Lebensdauer garantiert.

Das Produkt ist für 1 Jahr, ab dem Kaufdatum, gewährleistet. Beim Auftreten eines Schadens, durch schlechten Werkstoffe oder Verarbeitung, sollte das fehlerhafte Produkt an den ursprünglichen Verkäufer zurückgegeben werden. Eine Rückerstattung oder einen Umtausch erfolgt nach Vorschriften des Unternehmens.

Duronic Produkte haben 1 Jahr Gewährleistung unter folgenden Bedingungen :

1. Das Produkt sollte mit dem ursprünglichen Kaufnachweis zurückgegeben werden.
2. Das Produkt sollte unter den Anweisungen und Anleitungen installiert und benutzt worden sein.
3. Die Produkte sind nur für den Hausgebrauch geeignet.
4. Natürliche Abnutzung oder Schäden, böswillige Beschädigung, Missbrauch, unsachgemäße Reparaturen von Verschleißteile sind von der Gewährleistung ausgeschlossen.
5. Shine-Mart Ltd hat keine Verantwortung für indirekte Verluste oder Folgeschäden.
6. Shine-Mart Ltd ist nicht für Wartungsarbeiten zuständig. Diese fallen nicht unter die Gewährleistung.
7. Gültig in der EU



Dieses Produkt ist mit fitted CE geprüfte Typ-F  
Euro Stecker/BS Stecker ausgestattet  
Von Shine-Mart Ltd, RM3 8SB importiert



Information über Abfalllagerung für Verbraucher von elektronischen Geräten. Dieses Zeichen auf dem Produkt und/oder auf mitgelieferte Dokumenten zeigt, dass wenn eine Beseitigung erfolgt, diese an Elektro-Altgeräte (WEEE)- Stellen beseitigt werden muss. Für weitere Behandlungen und Weiterverarbeitung der Werkstoffe, dürfen diese WEEE- markierte Produkte nicht mit dem Hausmüll vermischt werden.

Für die korrekte Behandlung, Aufbereitung und Wiederverwendung bitte alle WEEE -markierten Produkte zu Ihren kommunalen Abfallbeseitigungsanlage nehmen. Dort können Sie diese kostenlos abgeben.

Wenn die Beseitigung von Elektro-und Elektronik-Altgeräten richtig beseitigt wird, werden Sie helfen, wertvolle Ressourcen zu gewinnen und mögliche negative Auswirkungen auf Gesundheit und der Umwelt zu vermeiden.

**Folgen Sie Uns**



[duronic.com](http://duronic.com)

**Manual De Instrucciones En Español**

## Safety Information



The lightning flash and arrowhead within the triangle is a warning sign alerting you of “dangerous voltage” inside the product.



**WARNING:** To reduce the risk of an electric shock, do not remove the cover (or back). No user-serviceable parts inside. Refer servicing to qualified service personnel.



**CAUTION:** The exclamation point within the triangle is a warning sign, alerting you of important instructions accompanying the product.



**CAUTION:** To reduce the risk of fire or electric shock or damage, do not expose this appliance/ apparatus to dripping or splashing liquids. Also, make sure that no objects filled with liquids are placed on the appliance/ apparatus.

**Note:** The rating label for this product is located on the bottom of the unit.

**Caution:** Grounding or polarization: precautions should be taken so that the wider blade of the ac plug (of ac-adaptor) must match the slot in the outlet “wall socket”. (Only if your ac plug is polarized)

**Note:** Caution symbols are printed on the rear of the unit or accessories. Please refer to the instruction manual.

**Caution:** Danger of explosion if battery is incorrectly replaced. Replace only with the same or equivalent type. Battery replacement must only be done by a qualified professional technician.

- Keep minimum distance (5cm) around the apparatus for sufficient ventilation.
- The ventilation should not be impeded or covered with items such as newspaper, table-cloths, curtains etc.
- No naked flame sources such as lit candles should be placed on the apparatus.
- This appliance/ apparatus is intended domestic use only.

**Caution:** Invisible laser radiation is present when the appliance is open, avoid exposure to beam.

## Parts & Assembly

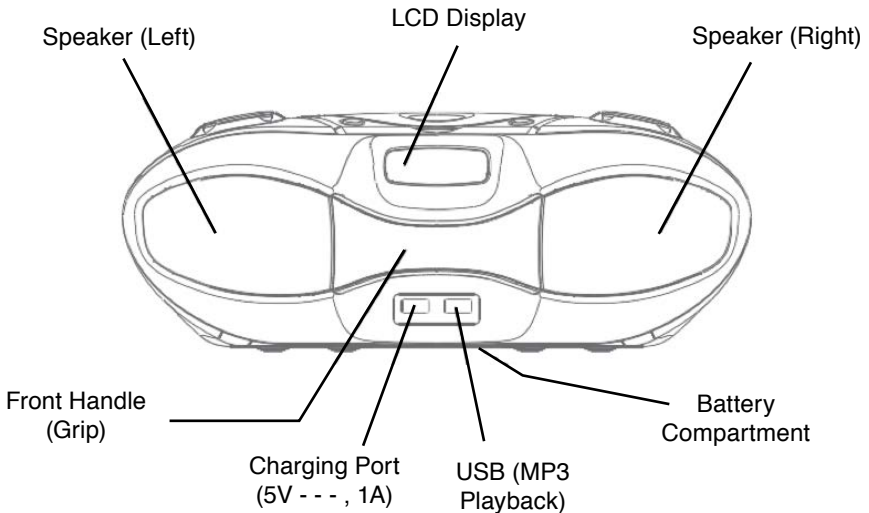
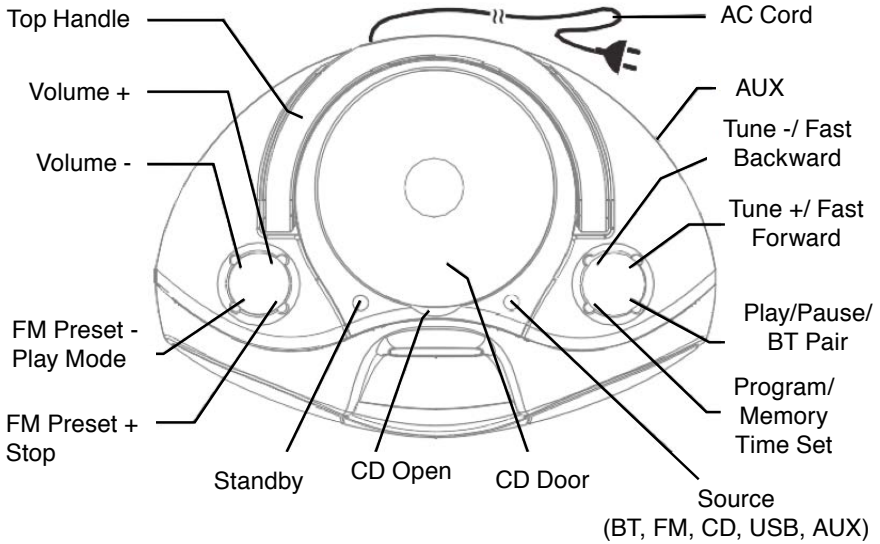



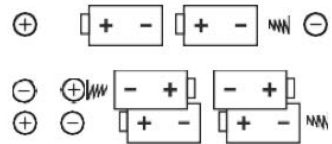
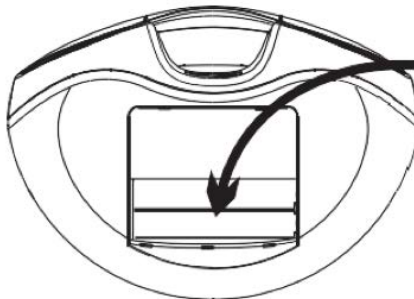
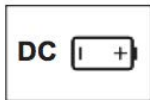

**1.5V x 6 PCS.**

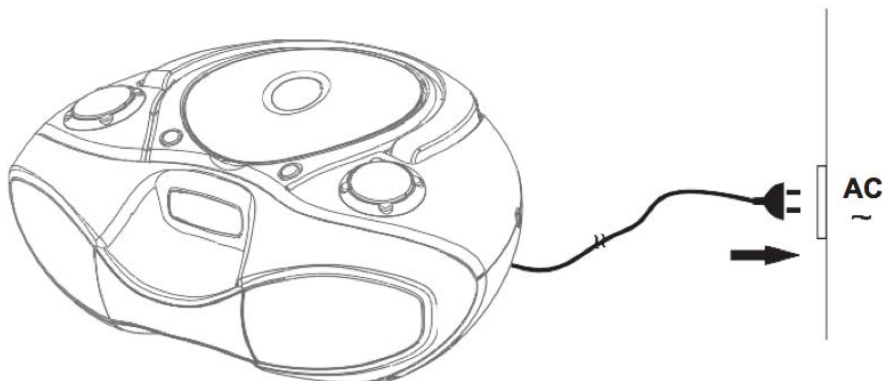



① "STAND-BY"

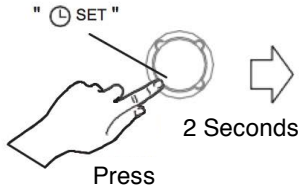

LCD:

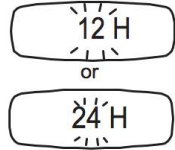

② 12H or 24H?

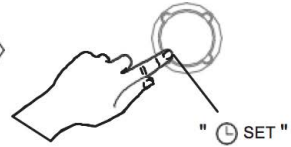
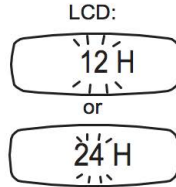
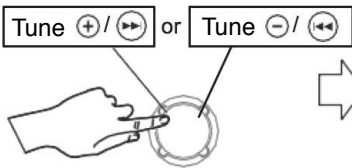

OK!

③ Hour Setting

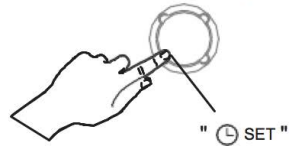
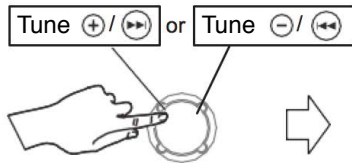

OK!

④ Minute Setting

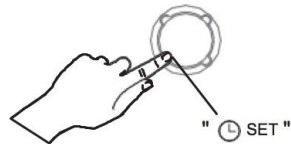
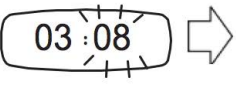
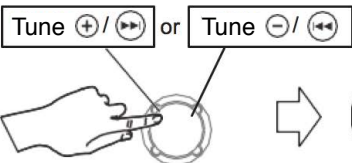

OK!

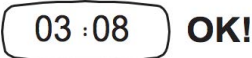



①

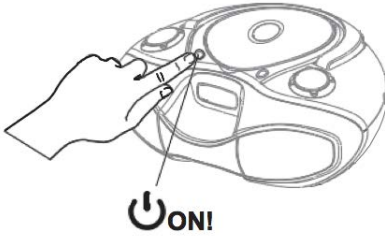

BT "ON" !

②

SOURCE = BT

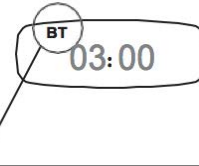
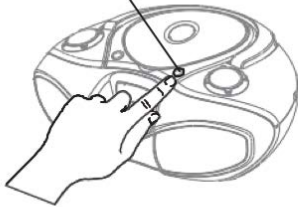

⋄ BT ⋄	Slow	=			Searching
⋄ BT ⋄	Fast	=	→		← Pairing (Code:0000)
BT	On	=			Connected

In order to avoid interference, please de-activate Wi-Fi on your device (smartphone, tablet, etc.) when playing music using Bluetooth®

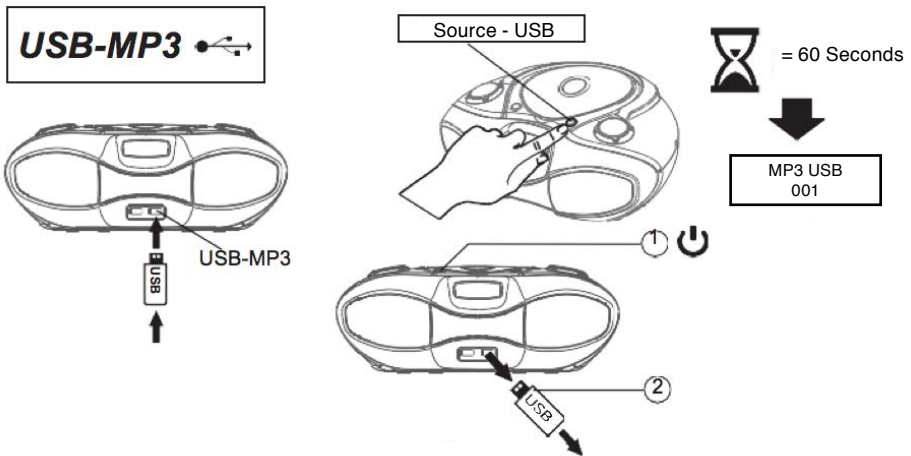
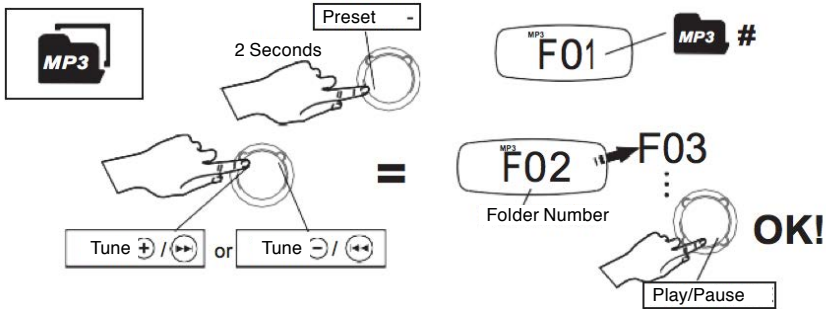
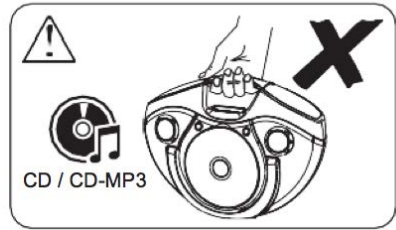
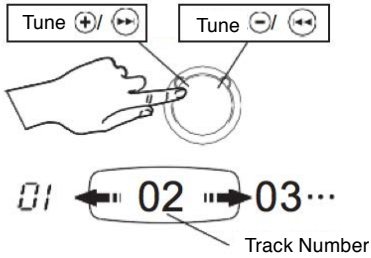
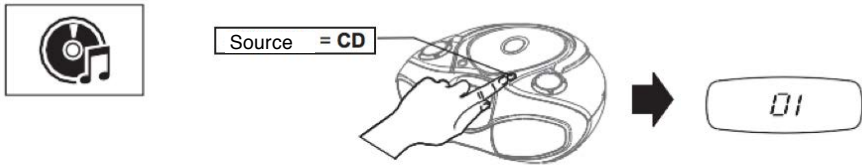

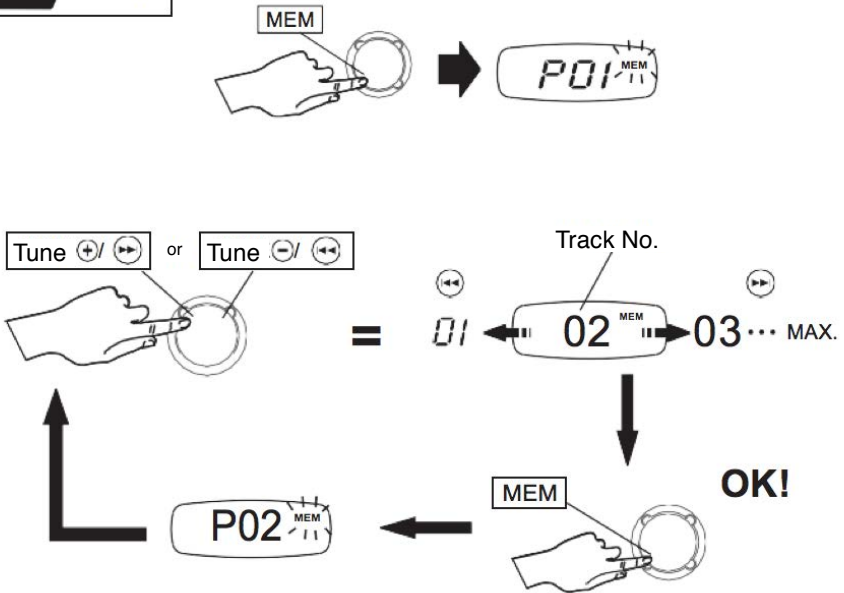
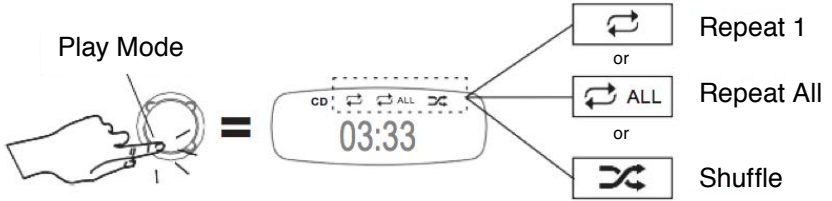
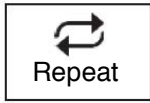

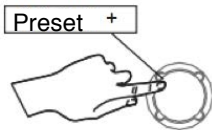
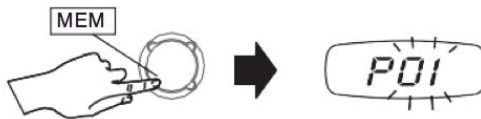
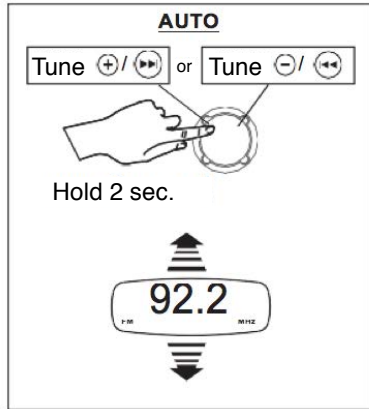
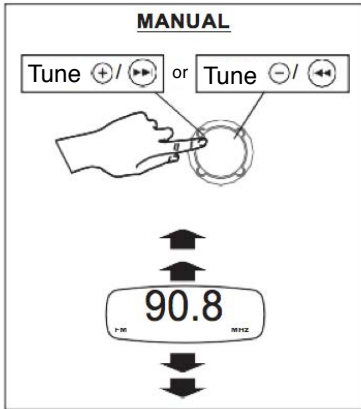
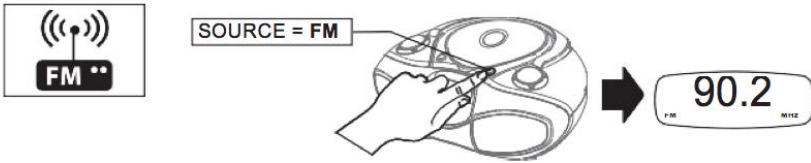

or

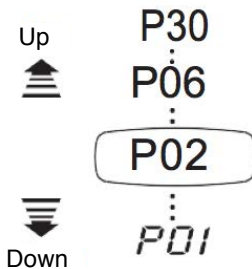
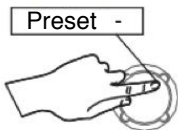

MAX. FM MEM = P30



**OK!**

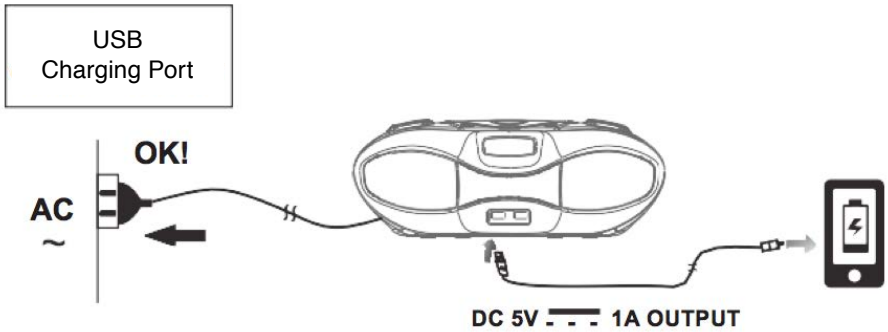
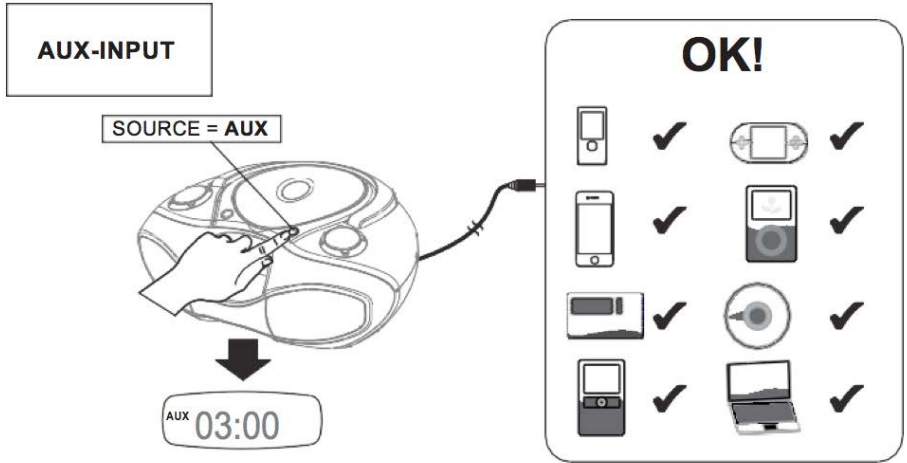

Power Supply: AC100-240V~50/60Hz  
 DC 9V - - - (6 x C-CELL/ UM-2/ LR14 SIZE)  
 (BATTERIES NOT INCLUDED)

Recharge Power: USB 5V - - - 1A  
 Frequency: FM 87.5 - 108 MHz  
 Wireless Range (BT): 10M (30 Ft.)  
 FM Station Memory: 30 Stations  
 CD Program Memory: 20 Songs  
 MP3 Program Memory: 99 Songs

# Garantía

NOTA: ESTAS DECLARACIONES NO AFECTAN SUS DERECHOS LEGALES COMO CONSUMIDOR

Este producto ha sido fabricado bajo las más estrictas control de calidad y utilizando materiales de alta calidad para asegurar confiabilidad y excelente funcionamiento. Le dará buen servicio y una larga duración, siempre y cuando se utilice correctamente y sea bien mantenido.

El producto está garantizado por 1 año desde la fecha de compra original. Si surge cualquier defecto debido a un error/defecto de fábrica o mano de obra, entonces el producto debe ser devuelto al lugar original de compra. Reembolso o reemplazo es a discreción de la compañía.

Productos Duronic se ofrecen con una garantía de 1 año bajo las siguientes condiciones:

1. El producto debe ser devuelto al vendedor con comprobante de compra original.
2. El producto debe instalarse y usarlo según las instrucciones contenidas en este manual.
3. Este aparato es únicamente de uso doméstico.
4. No cubre desgaste, daños maliciosos, uso indebido, negligencia, reparaciones inexpertas o partes consumibles.
5. Shine-Mart Ltd no será responsable por cualquier daño consecuente, accidentes o pérdidas.
6. Shine-Mart Ltd no es responsable ah llevar a cabo cualquier tipo de servicio, bajo la garantía.
7. Valido solamente dentro de la (EU).



Este producto esta equipado con enchufe/fusible Europeo  
Importado por Shine-Mart Ltd, RM3 8SB



Información sobre la eliminación de residuos para los consumidores de equipos eléctricos y electrónicos:

Esta marca en un producto y/o documentos adjuntos indica que cuando se va a desechar, se debe tratar como equipos residuos eléctricos y electrónicos (RAEE)

Cualquier producto marcado (RAEE) no debe ser mezclado con la basura doméstica, sino separado para el tratamiento, recuperación y reciclaje de los materiales utilizados.

Para el tratamiento adecuado, recuperación y reciclaje; por favor, tome todos los productos (RAEE) y llévelo al sitio de residuos de su Autoridad Local, donde será aceptado de forma gratuita.

Si los clientes desechan los residuos eléctricos y electrónicos correctamente, ayudar a ahorrar valiosos recursos y prevenir los efectos negativos sobre la salud humana y el medio ambiente, de materiales peligrosos que pueden contener los residuos

Síguenos



[duronic.com](http://duronic.com)



**Manuale D'istruzioni In Italiano**

## Safety Information



The lightning flash and arrowhead within the triangle is a warning sign alerting you of “dangerous voltage” inside the product.



**WARNING:** To reduce the risk of an electric shock, do not remove the cover (or back). No user-serviceable parts inside. Refer servicing to qualified service personnel.



**CAUTION:** The exclamation point within the triangle is a warning sign, alerting you of important instructions accompanying the product.



**CAUTION:** To reduce the risk of fire or electric shock or damage, do not expose this appliance/ apparatus to dripping or splashing liquids. Also, make sure that no objects filled with liquids are placed on the appliance/ apparatus.

**Note:** The rating label for this product is located on the bottom of the unit.

**Caution:** Grounding or polarization: precautions should be taken so that the wider blade of the ac plug (of ac-adaptor) must match the slot in the outlet “wall socket”. (Only if your ac plug is polarized)

**Note:** Caution symbols are printed on the rear of the unit or accessories. Please refer to the instruction manual.

**Caution:** Danger of explosion if battery is incorrectly replaced. Replace only with the same or equivalent type. Battery replacement must only be done by a qualified professional technician.

- Keep minimum distance (5cm) around the apparatus for sufficient ventilation.
- The ventilation should not be impeded or covered with items such as newspaper, table-cloths, curtains etc.
- No naked flame sources such as lit candles should be placed on the apparatus.
- This appliance/ apparatus is intended domestic use only.

**Caution:** Invisible laser radiation is present when the appliance is open, avoid exposure to beam.

## Parts & Assembly

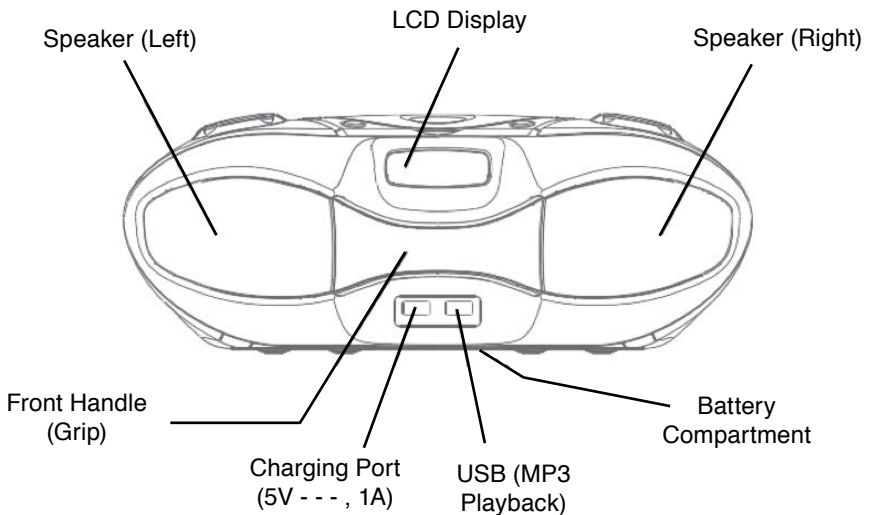
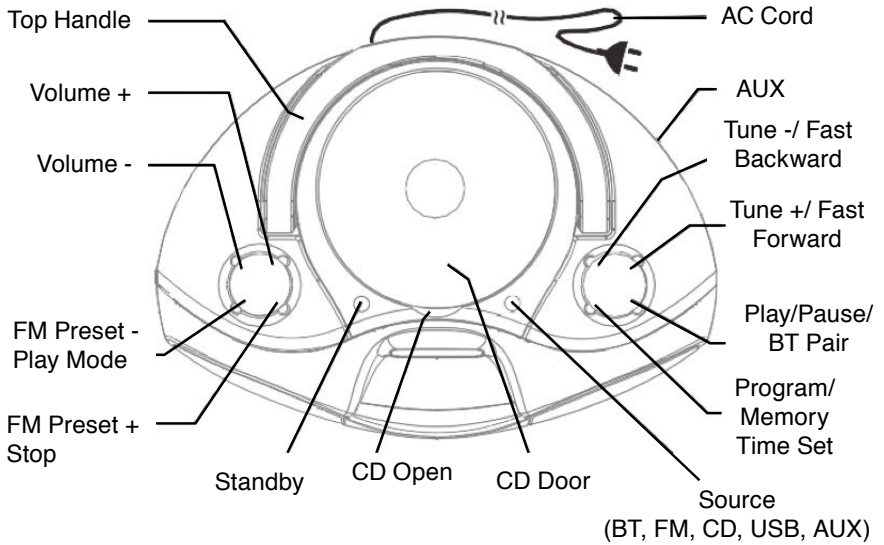

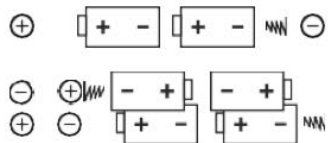
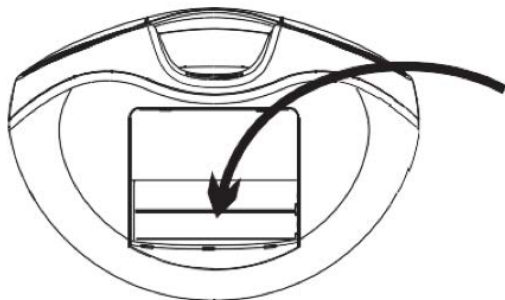

**1.5V x 6 PCS.**

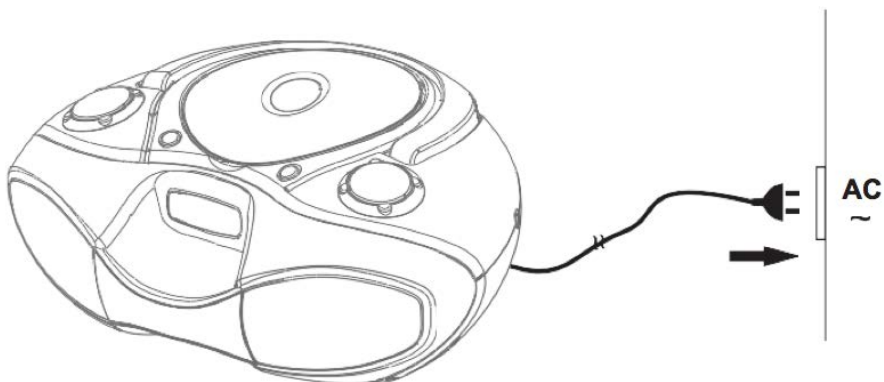



① "STAND-BY"

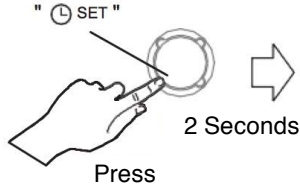

LCD:

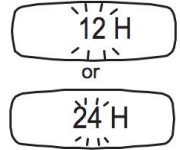

② 12H or 24H?

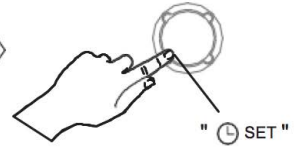
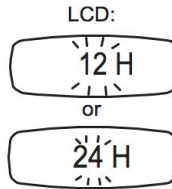
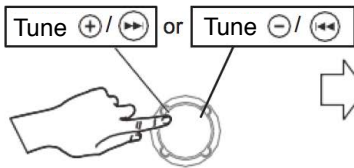

OK!

③ Hour Setting

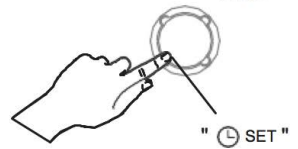
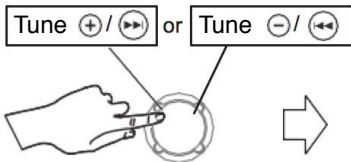

OK!

④ Minute Setting

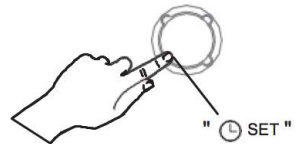
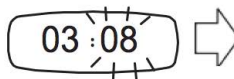
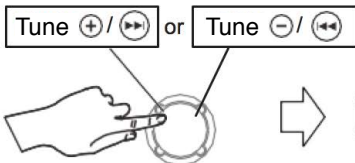

OK!





①

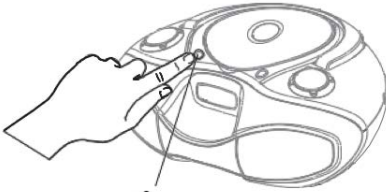

ON!



BT "ON" !

②

SOURCE = BT

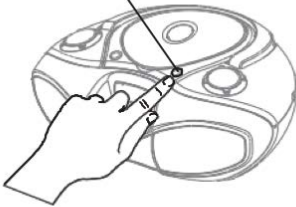

BT	Slow	=			Searching
BT	Fast	=	→		← Pairing (Code:0000)
BT	On	=			Connected

In order to avoid interference, please de-activate Wi-Fi on your device (smartphone, tablet, etc.) when playing music using Bluetooth®

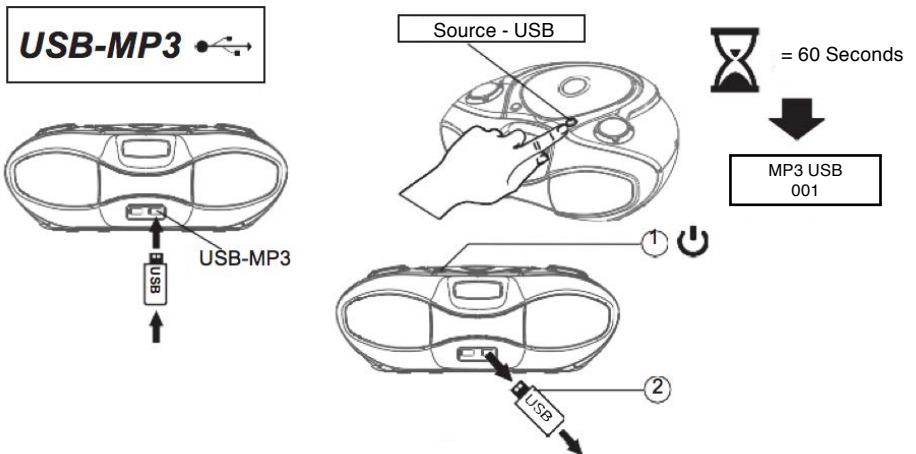
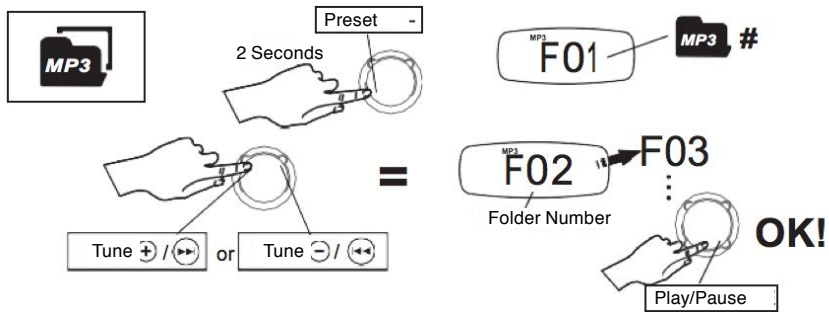
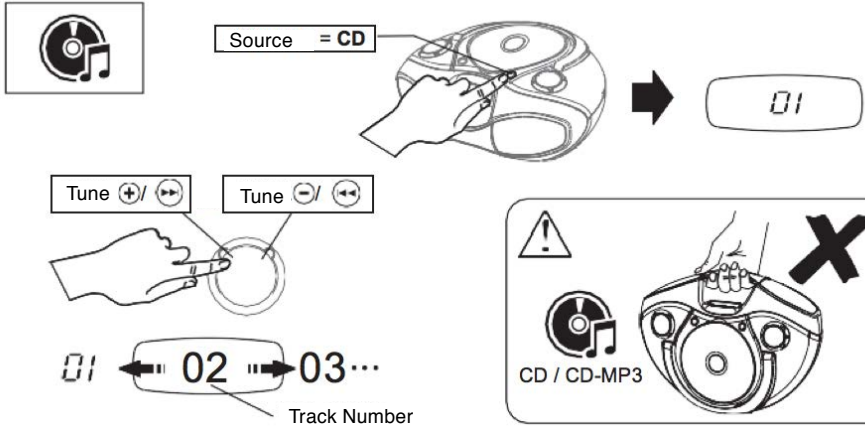

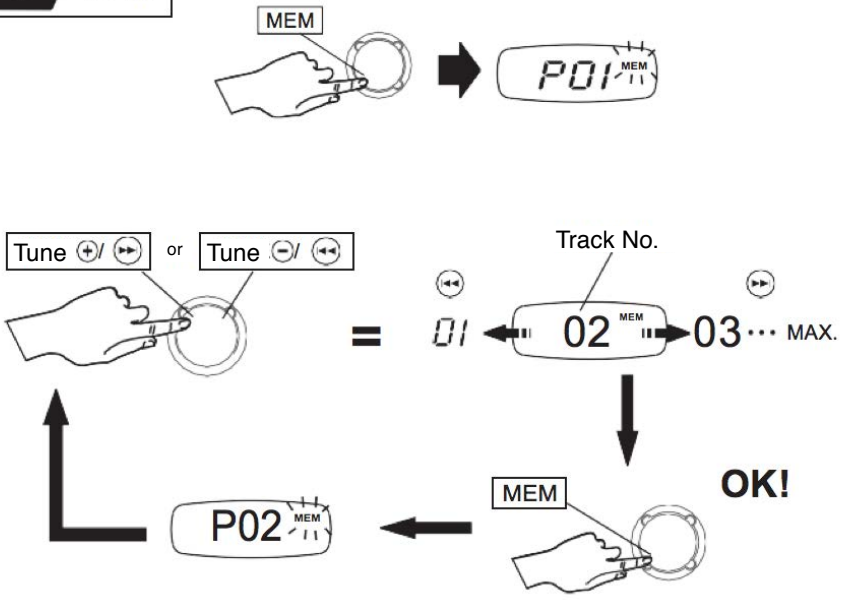
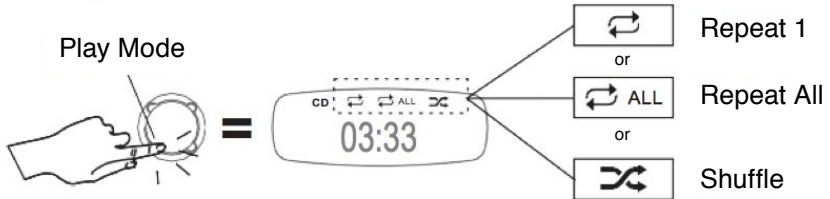
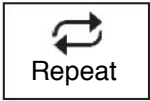



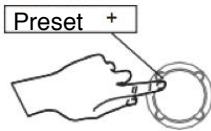
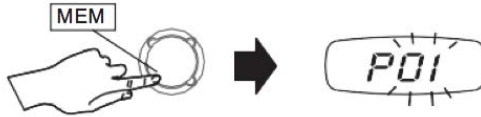
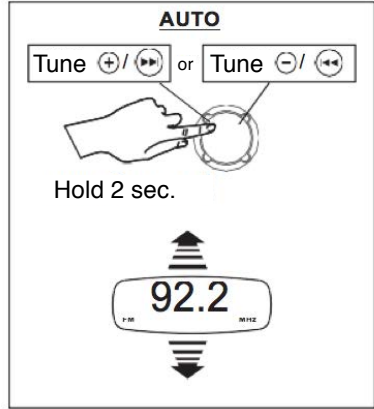
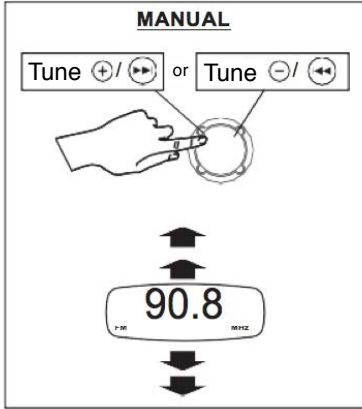
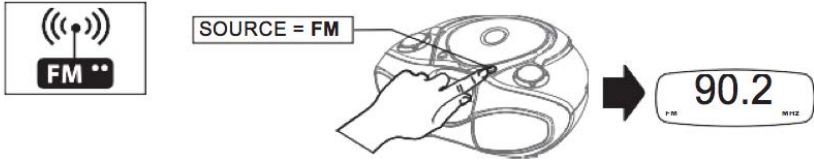

or

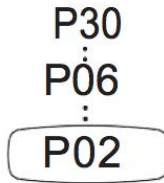
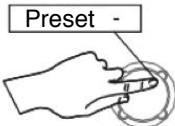

MAX. FM MEM = P30



**OK!**

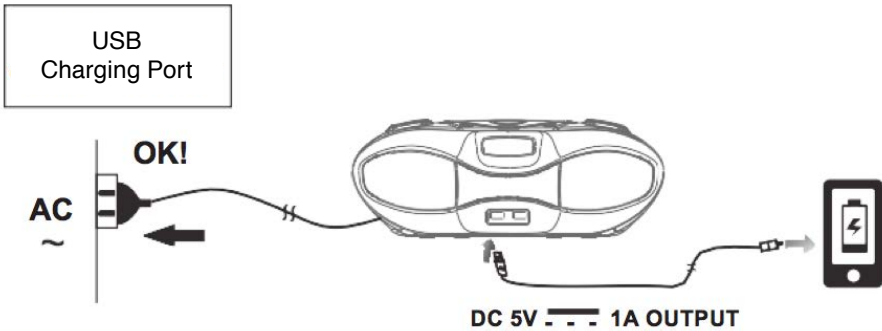
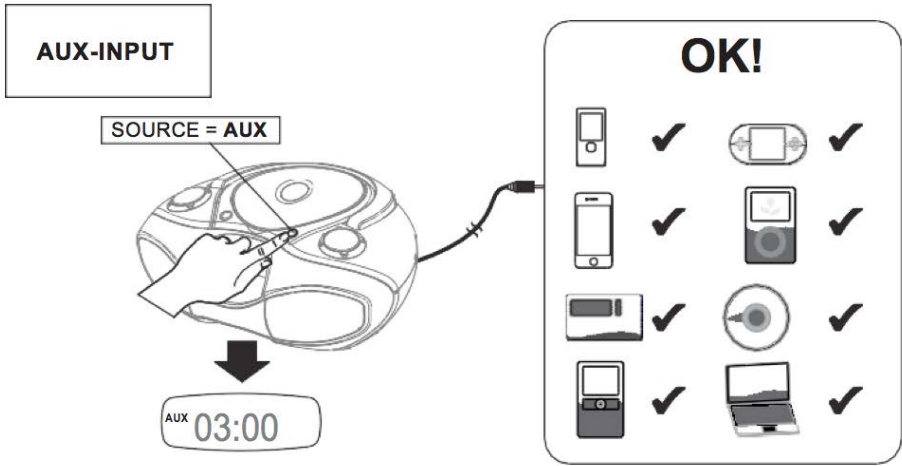

Power Supply: AC100-240V~50/60Hz  
 DC 9V - - - - (6 x C-CELL/ UM-2/ LR14 SIZE)  
 (BATTERIES NOT INCLUDED)

Recharge Power: USB 5V - - - - 1A  
 Frequency: FM 87.5 - 108 MHz  
 Wireless Range (BT): 10M (30 Ft.)  
 FM Station Memory: 30 Stations  
 CD Program Memory: 20 Songs  
 MP3 Program Memory: 99 Songs

# Garanzia

Questo prodotto è garantito per una durata determinata con il distributore a partire dalla data di acquisto contro ogni difetto derivante da difetti di fabbricazione o dei materiali. Questa garanzia non copre difetti o danni derivanti da installazione impropria, uso improprio o usura anomala del prodotto.

L'apparecchio deve essere restituito nella sua confezione originale e accompagnato dalla ricevuta e deve essere stato utilizzato in modo corretto. È importante rispettare le istruzioni per l'uso e le precauzioni di sicurezza indicate di seguito. Inoltre, non possiamo garantire l'apparecchio se è stato modificato o riparato dall'acquirente o da terzi.

1 anno di garanzia da Shine-Mart Ltd, proprietari del marchio commerciale Duronic.

**NOTA: QUESTE DICHIARAZIONI NON INFLUISCONO SUI DIRITTI LEGALI DEL CONSUMATORE**

Questo prodotto è stato realizzato con le rigorose procedure del controllo qualità, e utilizzando materiali di altissima qualità, per garantire affidabilità e prestazioni eccellenti. Vi regalerà un servizio ottimo e a lungo termine, purchè venga opportunamente usata e mantenuta. Il prodotto è garantito per 1 anno dalla data di acquisto. Se sorge qualche difetto a causa di materiali difettosi o scarsa manodopera, il prodotto difettoso dovrà essere restituito al luogo originale di acquisto. Il rimborso o la sostituzione sono a discrezione dell'azienda. I prodotti Duronic offrono 1 anno di garanzia alle seguenti condizioni:

1. Il prodotto deve essere restituito al rivenditore con la prova d'acquisto originale
  2. Il prodotto deve essere installato e usato seguendo le istruzioni contenute nel manuale.
  3. Il prodotto va utilizzato solo per scopi domestici. Non è da utilizzarsi per uso commerciale.
  4. La garanzia non copre usura, danni volontari, abuso, negligenza, riparazioni inesperte o consumo dei materiali.
  5. Shine-Mart Ltd non è responsabile per Danni accidentali o consequenziali.
  6. Shine-Mart Ltd non è tenuta a eseguire qualsiasi tipo di riparazione, ai sensi della garanzia.
  7. Termini validi in tutta l'unione europea \*Ci riserviamo il diritto di modificare le sopracitate condizioni Per parti di ricambio si prega di consultare il sito [www.duronic.com](http://www.duronic.com)
- Corretto smaltimento del prodotto.



Questo prodotto è inclusivo di spina certificata CE  
importata da Shine-Mart Ltd, RM3 8SB



Questo segno su un prodotto o su documenti indica che quando deve essere smaltito, deve essere trattato come i rifiuti elettrici ed elettronici (WEEE). Tutti i prodotti marcati WEEE non devono essere buttati nei rifiuti domestici generici, ma separati per il trattamento, il recupero e il riciclaggio dei materiali utilizzati.

Per un corretto trattamento, recupero e riciclaggio; si prega di portare tutti i prodotti marcati WEEE al Vostro centro smaltimenti rifiuti autorizzato, dove saranno accettati gratuitamente.

Se i consumatori sono propensi allo smaltimento corretto di rifiuti elettrici ed elettronici, aiuteranno a salvare risorse importanti e a prevenire i potenziali effetti negativi sulla salute umana e sull'ambiente di tutti i materiali pericolosi che i rifiuti possono contenere.

Seguici



[duronic.com](http://duronic.com)

**DURONIC**