



# TOSHIBA

Microcomputer Induction Rice Cooker

For Household Use

## Instruction Manual

Model 1.0L

RC-10IR1PP

Production of origin: China

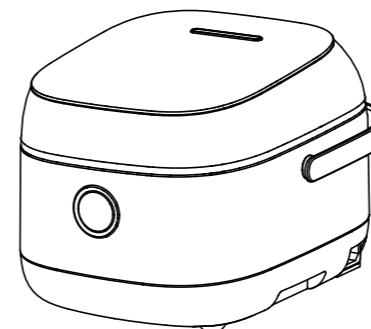

Thank you for buying the Toshiba Microcomputer Induction Rice Cooker.

- Do not use this appliance to any voltage except for 220~240V AC to avoid the risk of fire and electric shock.
- This product is for household use only. (Please do not use as a commercial product.)
- Please read the instruction manual carefully and use this product correctly for your own safety.
- After reading, please keep this instruction manual properly in a place where you can check it at any time.

Before using, please read and follow "Important Safety Instructions"(Pages 2-5)

### Table of Contents

Before use	<b>Important Safety Instructions</b> .....	<b>2</b>
	<b>Attention</b> .....	<b>5</b>
	Parts name.....	6
Cooking	▪ Disassembly & assembly of removable cover plate and steam valve.....	8
	▪ Method of opening and closing upper housing.....	9
	▪ Display of cooking time.....	9
	▪ Sound.....	9
	<b>Rice cooking method</b>	
	Basic procedures.....	10
	▪ Key points to cook delicious rice.....	11
	Cooking mode.....	12
	<b>Cooking capacity and corresponding cooking time estimation</b> .....	<b>12</b>
	▪ Setting method of rice cooking.....	14
Main - te- nance	<b>Method of presetting cooking time</b> .....	<b>15</b>
	<b>Method of adjusting the current time (clock)</b> .....	<b>16</b>
	Dishesy.....	18
	Keep Warm.....	20
	Maintenance.....	21
This time	▪ Cleaned by boiling.....	22
	<b>How to deal with cooking failure</b> .....	<b>23</b>
	<b>Error display</b> .....	<b>25</b>
	<b>When there is the power outage</b> .....	<b>25</b>
	<b>Lithium batteries</b> .....	<b>25</b>
Specifications.....	26	

# Important Safety Instructions Please observe for security

This manual contains the following important contents, to prevent damage to your personal and property safety, and for you to use this product safely and correctly.

## ■ Classify and explain the extent of hazards and damages caused by non-compliance with the recorded use methods.

 **Warning** Contents of the possibility of causing "death" and "serious injury"

 **Note** Contents of the possibility of "minor injury" and "losses of housing and property".

## ■ Classify and explain the contents to be observed.

 Contents of "FORBIDDEN"

 Contents of "Observe Instructions"

 Contents of "Supervising and Note"

## **Warning** For the purpose of preventing fire, scald, electric shock, electric leakage, short circuit, etc.

 **The following persons are not allowed to use this product**

- Children
- Persons with reduced physical, perceptual or intellectual abilities
- Persons lack of experience and knowledge

Please keep this product out of the reach of children and do not let children play with it.

 **Do not use this product for any purpose other than those indicated in the instruction manual.**

It may cause fire, burns, injury, or electric shock. Toshiba doesn't assume any responsibility for the consequences of improper use of this product or use for purposes other than those described in the instruction manual.

 **Immediately stop using in the event of an exception or failure**

Immediately pull out the power plug and consult the dealer where you purchased the product **(Exceptions and failure examples)**

- The power plug or power cord is abnormally hot
- Burnt smell from the cooker
- Part of the cooker is cracked, loose, or rattled
- Inner pot, lid or removable lid is deformed or broken

 **Do not disassemble, repair or modify by yourself.**

For any repair, please consult the Store from which the product was bought or Toshiba Service Center.

 Disassembly prohibited

 **Do not put any foreign objects in the air inlet, outlet or slot in the bottom of the cooker**

Especially such as pins and wires

 Do not put in foreign objects

 **Do not wash the cooker, power plug, or power cord with water.**

**Do not allow the cooker to get wet with water or pour water onto it.**

**Do not pour water into the cooker.**

Do not immerse the cooker in water.

 Do not pour water onto it

 **Do not let the children or anyone unfamiliar with the operation to use the cooker. Please keep the cooker out of the reach of children.**

**Keep your attention to your child during or shortly after cooking.**

 **Do not open the lid or move the cooker during cooking**

※ Please refer to the actual product if the product picture is inconsistent with the actual product.

In case of cord damage, the cord should be replaced with a special cord or specialized component purchased from the Manufacturer or the Maintenance Department.

 **Warning** For the purpose of preventing fire, scald, electric shock, electric leakage, short circuit, etc.

### Use the power plug / Cord correctly.

 **Please do not attach the power plug (power supply side and body side) with pins or rubbishes.**

**Please do not use if the power plug (power supply side and body side) and power cord are damaged or the power socket is loose.**

**Please do not use power cords other than the special power cord.**

**Please do not use the power cord for other appliances.**

**Please do not damage the power plug or power cord.**

Do not bend, pull, twist or bundle the wires forcibly. Do not place the power plug or cord in the place with high temperature, flooded water and high humidity or touch it with sharp-edge object

**Please do not lick the power plug (power supply side and body side).**

Please do not let infants and young children lick the plug.

 **Please do not plug or unplug the power plug (power supply side and body side) with wet hands.**

Please ensure hands are dry before touching the power plug.

 Please do not touch it with wet hands.

 **The power socket with AC 220~240V and rated current of 10A or more should be used alone.**

It may cause fire due to heating when sharing socket with other equipment.

**The power socket with 10A above rated current should be used alone if the power cord should be extended.**

**The power plug (power supply side and body side) has been completely inserted.**

**Remove dust from the power plug (power supply side and body side) regularly.**

The accumulation of dust will produce moisture and cause poor insulation, which may cause fire, please wipe off with dry cloth.

**Please do not place the power cord in the place where children can take**

Please do not hang the power cord at the table or counter. The product will fall from the table or counter if the power cord is pulled, which may cause injury.

**Please be careful not to stumble or hook the power cord in service.**

It may cause injury or cause fire or electric shock due to the damaged power cord.

**Use grounded power socket.**

The power plug of this product can only be inserted into the grounded power socket. It may cause electric shock due to fault or electric leakage if grounding is not complete.

 **The steam vent is hot. Keep your hands or face away from it.**

Please pay special attention to infants and young children.

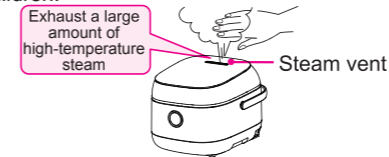

 **The steam valve is installed indeed.**

**Press to close the upper housing until a sound of "clatter".**  
**Warning: Misuse may cause potential injury.**

 **Please do not use for purposes other than the instruction manual.**

It may cause food or steam contained inside spill or burst out, resulting in burn wounds or injuries.

**(Examples of forbidden cooking methods)**

- Cuisines such as cream dessert, beans and noodles that will increase after stewing.
- Cuisines made by using baking soda that will sharply bubble.
- Sticky cuisines cooked with ground spices and curry that will be pasty.
- Cuisines that require a lot of oil.
- Cuisines such as beans and sauces that are easy to overflow.
- Cuisines that require packing food in plastic bags and heat in the induction rice cooker.

Before use

## Important Safety Instructions Please observe for security.

**Note** For the purpose of preventing injury, scald, electric shock, electric leakage, fire and home loss.

Please do not use device in these places.



**Easy to splash water or near fire.**

Please pay attention to the accessories.

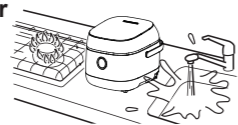

**Unstable premises or heat labile mats.**

It may cause injury, scald or fire.

**Near the heat labile curtains.**

This product is for indoor use only.



**Near walls or furniture.**

When using on the kitchen shelves, please pay attention to ventilation. Please do not let the steam blow to the operating parts, so that the steam can spill out from the shelves.

**Roller table with insufficient load-bearing strength.**

Please use a table with a load-bearing strength of more than 10kg.

**A place where the outer cover cannot be completely opened.**

It may cause scald or breakage.

**To prevent injury and scald.**



**Please do not touch the high temperature parts such as removable cover plate, inner cooking pot, steam valve, heat preservation base plate and outer casing cover in use and after use for a short time.**

Do not touch.

In addition, please note that when you scarify the rice, please do not touch the inner cooking pot with your hands.



**Please do not touch the button when moving the body. Please do not move with the cover.**

**Please do not cook in an empty pot.**

It may cause fault, overheating or abnormal work.



**Please use dry cloth or baking gloves to remove the hot inner cooking pot.**

Please do not touch the hot pot with your hands.

**During maintenance, the power plug should be unplugged. The body should be maintained after cooling.**

Hot water may be accumulated at the steam vent.

**After cooking, please be careful of steam dripping and high temperature water drops on the removable cover plate when opening the upper housing.**

**For your safe use**



**People with medical pacemakers should be consulted in detail.**

This product may affect the pacemaker when working.



**Please do not use deformed or non-dedicated inner cooking pots.**

Scald or injury may result from overheating or abnormal movements.

**Please do not turn the steam towards the power plug or other electrical equipment.**

Please pay special attention to the use of kitchen shelves and other items.



**When disconnecting the body with the power socket, please hold the power plug (power supply side and body side) to pull out.**

Fire may be caused by electric shock or short circuit.

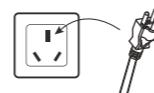

Please do not pull the power cord.



**When the induction rice cooker is not used, please pull the power plug (power supply side) from the power socket.**

Electric shock or electric leakage and fire may be caused by insulation deterioration.



**Note**

For the purpose of preventing injury, scald, electric shock, electric leakage, fire and home loss.

**To prevent overheating**



For products equipped with a metal steamer, the steamer should not be used separately as a heating container for cooking, so as to avoid overheating, plastic melting, or even fire accidents.

**Only use the original inner pot for the rice cooker.**

**To prevent spray**



**Please do not select <QUICK COOK> or other similar cooking modes for porridge and coarse food grain rice when more water is required.**

Please select <Porridge> mode when cooking porridge.

**Please do not exceed the water level scale too much when adding water**

Less than 1mm within the scale is better.

## Attention

Please follow the following precautions to prevent faults and erroneous operations.

**Place and surroundings.**

**Please do not place them in direct sunlight or oil spatter.**

It may cause deformation or discoloration.

**Clean the body and its surroundings.**

If dusts or insects enter the suction port and exhaust port that maintain the functions of the induction rice cooker, the electric cooker will cause faults.

**Please keep away from items easily affected by magnetic force.**

If not, the contents stored on bank cards, IC cards and like may be eliminated. There may be noise on TV, radio and telephone.

Before use

**About use**

**Please do not use when sticking foreign matters or water drops.**

When in service, if the foreign matters attached to the outside of the inner cooking pot or the temperature sensor and the inner cover washer are not erased, cooking will not be completed smoothly, or faults will occur.

**Please do not use on the induction cooker.**

It will cause faults.

**Please stop using in case of falling, cracks or rattles of the body.**

Please ask the store for inspection and maintenance.

Pay attention to the cleanliness between the inner pot and the seal ring to prevent the inclusion of rice grains or large foreign particles, this may cause steam to overflow and cause burns or other malfunctions.

Do not use this cooker for food that may block the exhaust vent.

**Please do not cover the upper housing, especially the steam valve, with the duster cloth and coarse cotton cloth.**

The steam that cannot be discharged may cause the display part to become blurred, and cause the upper housing, steam valve and operation resulting in malfunctions, deformation, discoloration.

Please do not ward off the steam valve.

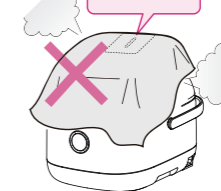

**About inner cooking pot**

**Please do not put the inner cooking pot on the gas stove to burn it, or put it on the induction cooker or in the microwave oven.**

It may cause deformation, discoloration or faults.

**Please do not bump against the inner cooking pot or drop it on a hard substance.**

It may cause damage and deformation on the outside of the inner cooking pot.

**Please do not damage the fluororesin coating on the inner surface of the inner cooking pot.**

Otherwise, the fluororesin coating will be split from the inner surface of the inner cooking pot. (See Page 22 for details.)

## Parts name

- When using for the first time, please clean the inner cooking pot, inner cover, steam vent and accessories.
- At first use, there might be an odor from plastic, which will gradually disappear after using.
- The configuration of accessories varies depending on the product model.
- Due to the difference in appearance and function of different models, please refer to the actual product and read the corresponding function description.

### Body

Maintenance methods of each part

#### Steam valve

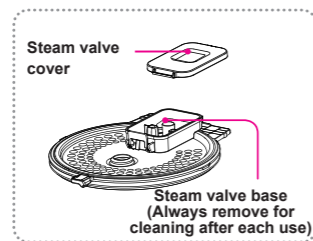

Installing removable cover plate



Handling methods for removable cover plate and steam valve

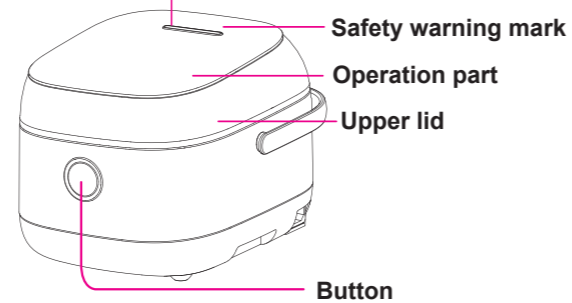

#### Cover plate button

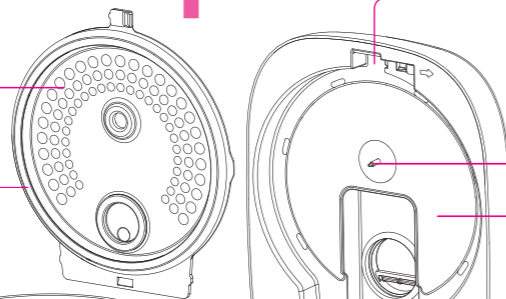

Temperature sensor of upper housing  
Insulation base

#### Movable cover plate

"Please clean it after use."  
The upper housing cannot be closed when there is no removable cover plate.

Sealing ring (remove foreign matters)

#### Healthy rice basket



#### Inner cooking pot

#### Outer casing cover

Suction port and exhaust port  
(bottom side)

#### Plug socket (rear face)

#### Power cord

Power plug (power supply side)



Power plug (body side)

## Power cord connection

- 1 Insert the power plug (body side) into the plug socket on the rear face

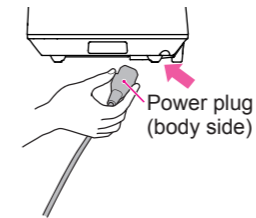

- 2 Insert the power plug (power supply side) into the power socket.

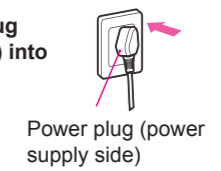

- ! Please exactly plug the power plug into the bottom.

### Operation part

Display part (The clock is of 24-hour display mode)  
Status of whole display

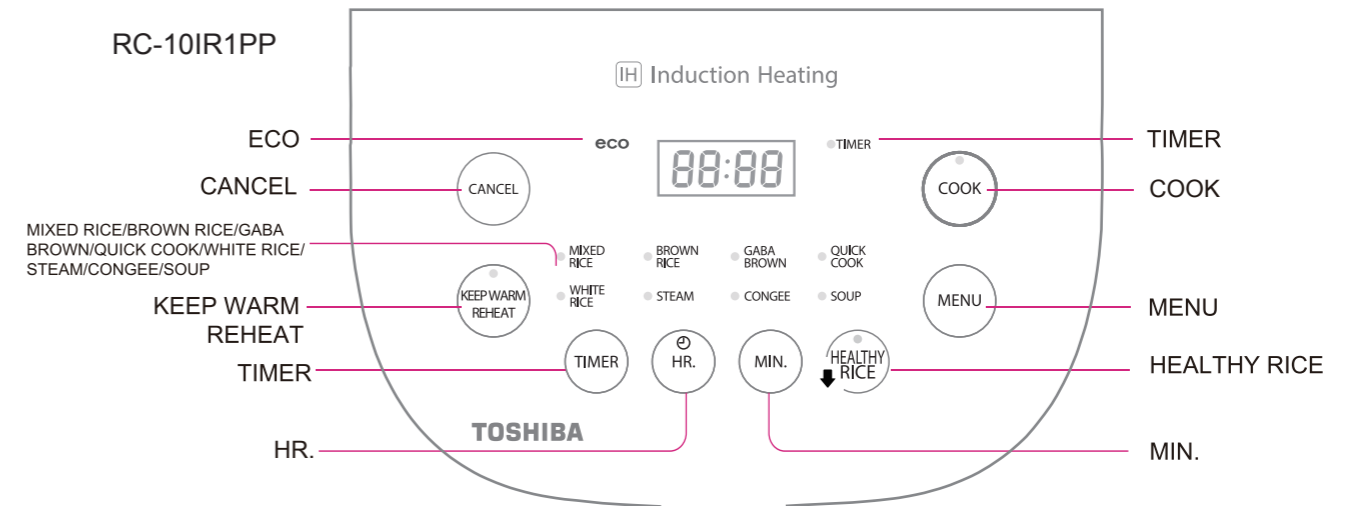

## Accessories

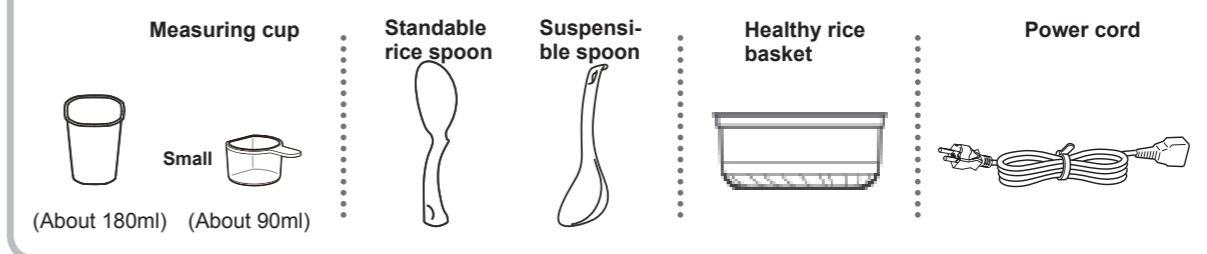

## Disassembly & assembly of removable cover plate and steam valve

### Remove the removable cover plate.

- 1 Push the inner cover slider to the right according to the arrow (the removable cover plate leans forward).
- 2 Grab the handle and pull up the removable cover plate.

When the removable cover plate is removed, the upper housing cannot be closed to prevent you from cooking without the removable cover plate.

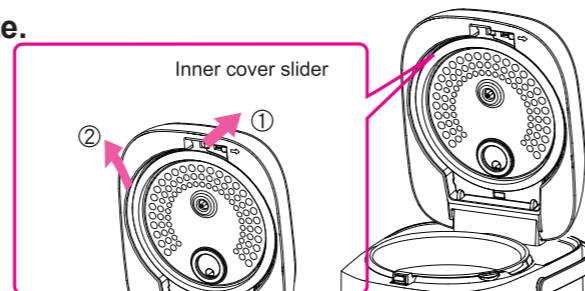

### Installation methods for removable cover plate

- 1 Lean and insert the inner cover into the slot from above.

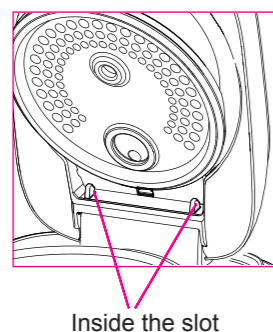

Inside the slot

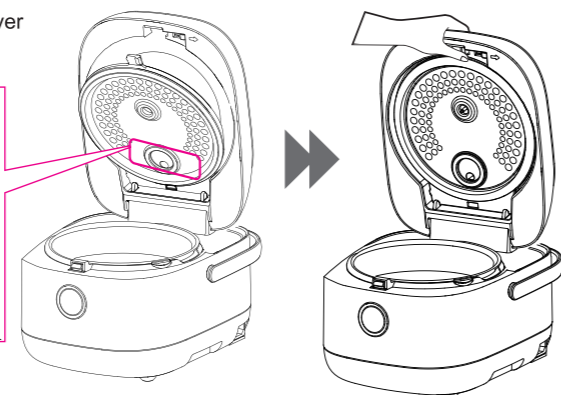

- 2 Push and press the handle until a "clicking" sound from the cover side.

## Method of opening and closing upper housing

### Open the upper housing

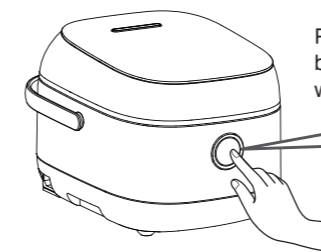

Please do not press the upper housing from above. You should just press the button before hearing the "clatter" sound of unlocking, and the upper housing will be opened.

Please do not press the upper housing from above. You should just press the button to open the upper housing.

### Close the outer cover.

Press the front center.

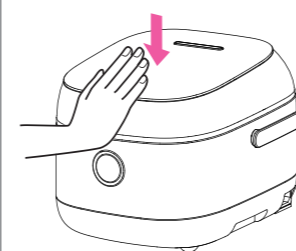

If the removable cover plate is not installed, the upper housing cannot be closed to prevent forgetting the installation of the removable cover plate.

! Before closing the upper housing, please confirm that there are no foreign matters on the opening button seat (Page 10).

! Press until a sound of "clatter".

Before use

## Display of cooking time (display of remaining time)

### Remaining time to complete cooking.



Every 5 minutes. Change display

↓ After converting to rice stew

Every 1 minutes. Change display

To adjust display time before converting to rice stew, display time will be moved up or stopped. The time displayed is an approximate one.

## Sound

### Sound in use (it will send sound during use)

Sound of "squeak..." .... Power-on sound of induction heating. (It will occasionally send out "squeak..." during heat preservation)

Sound of "hum..." .... Fan rotating sound of internal heat dissipation.

Sound of "whew..." .... Sound of steam spraying out from steam vent.

### Sound of buzzer

Volume of buzzer sound cannot be changed or eliminated

# Rice cooking method Basic procedures

**Preparation** Connect to power cord

Basic procedures

**1 Rice measurement** Use the attached measuring cup

[Correct case]

[Wrong case]

1 plain cup = about 180ml  
Small 1 plain cup = about 90ml

- Using measuring cup for cooking (200ml) may cause errors.

**2 Wash rice quickly** Until water gets clean

Inner cooking pot can be used to wash rice

- Add adequate water and fully mix and then promptly pour water out.
- Repeat "mixing" and "washing with water" until water gets clean.

- Please do not use egg beater to wash rice in inner cooking pot.

**3 Select water level scale** Adjust water volume based on the number of cups of rice

Flatten rice and place on a horizontal place

Press the water level scale of "White Rice" for adjustment during rice cooking. (Other water level scales...Page 12)

- Increase or decrease water volume based on personal tastes. (Within 1mm above or below the scale.)
- Press **START** (COOK) button, it will automatically start rice soaking. Therefore, there is no need for rice soaking before cooking.

**4 Wipe off attached water drops and foreign matters, place in inner cooking pot and close the cover.**

Wipe off water outside inner cooking pot.

Press until a sound of "clatter".

Please timely wipe off if any foreign matters or water drops attached to the following parts.

If any attached foreign matters or water drop, it cannot cook smoothly and may cause covering failure, steam leakage and other problems.

**5 Set and confirm the cooking mode to start cooking.**

Press **START** (cook) button

- The **START** indicator light turns on after pressing **START** (cook) button, and the time left before cooking is displayed. (Display is changed every 5 minutes before converting to rice stew.)

**Cooking is done when buzzing** KEEP WARM light up ▶ Press **OFF** button after using and pull out the power plug.  
 Take out inner cooking pot, and be sure to press **OFF** (CANCEL) button to cut off power.

During "Prompt cooking with no need for heat preservation" and "Continuous cooking", please start to cook after temperature of slot and inner cover of inner cooking pot is lowered. (Rice may not be cooked well.)

## Key points to cook delicious rice

**Add rice horizontal to measuring cup opening**

Attached measuring cup

Please do not shake the measuring cup

More rice will be filled after shaking the measuring cup.

**Please do not wash rice with hot water Rice should not be washed too long**

In case of washing rice with hot water or washing too long, the rice will send out the smell of rice bran powder.

**Wash rice softly in case of crushing the rice.**

Slightly friction rice grains. (Crushed rice will be sticky after cooking)

**Increase or decrease water volume based on personal tastes**

Prefer to hard-boiled rice	Slightly less than the scale
Prefer to soft-boiled rice	Slightly more than the scale
New rice	Slightly less than the scale
Milled rice with embryo	Subject to the scale
Rice stocked for years Plum rain season-Summer	Slightly more than the scale

Rice of different brands, different origins and different stock methods is in different states. Please adjust water volume based on personal tastes.

**Scarify the rice promptly after completing cooking**

Scarify with dry duster cloth or baking gloves to press the inner cooking pot bottom up, and scarify about 1/4 every time. Prevent rice from getting lumped and sticky.

**Heat preservation time (should not be too long)**

It's better to stock in refrigeration if "the heat preservation may be too long" or "there is a little rice".

**Rice**

- Use fresh white rice with the volume that can be eaten up within two weeks to one month every time.
- Please place rice into a closed container, and place in a dark place.

**Please do not drain off with shallow basket after rice washing**

It is forbidden to drain off with shallow basket after rice washing

It will make the crushed and boiled rice sticky

**Water not suitable for cooking**

Mineral water of relatively higher hardness

(It will make rice dry and hard)

Alkaline ionized water with pH value above 9

(It will make the rice yellow and sticky)

**Water temperature below 30°C**

It's better to use cold water to cook rice in summer.

( High water temperature will make cooked rice unpalatable or odorous )

**Maintain promptly after the body is cooled down after using.**

Wipe off water with clean duster cloth after washing clean. (The cooker will send out unpleasant odor if it is not washed after using)

Inner cover and steam vent shall also be washed clean after using.

Please do not keep the rice in the cooker all the time after cutting off heat preservation. (It will send out unpleasant odor)

# Cooking mode

Cooking capacity and corresponding cooking time estimation





Select "cooking mode" and "water level scale" based on type of cooking rice.

Cooking mode	Taste	Water level scale	Cooking capacity	Estimation of cooking time Unit: min ( ) First cooking time	TIMER (○: Valid, X: Invalid)
MIXED RICE	/	MIXED RICE	1-3	50-70(70)	○
BROWN RICE	/	BROWN RICE	1-3	65-85(80)	○
GABA BROWN	/	BROWN RICE	1-3	220-240(240)	○
QUICK COOK	/	WHITE RICE	0.5-5.5	18-35(18)	X
WHITE RICE	/	WHITE RICE	0.5-5.5	40-55(40)	○
STEAM	/	WHITE RICE (scale 2)	/	1-60 (Default 30 minutes, adjustable)	○
CONGEE	/	CONGEE	0.5-1	45-120 (Default 45 minutes, adjustable)	○
SOUP	/	CONGEE	0.5-1	120-240 (Default 90 minutes, adjustable)	○
HEALTHY RICE	/	HEALTHY RICE	1-2	40-55(40)	○

- The minimum capacity, maximum capacity and available cooking capacity of the water level scale of inner cooking pot differ from each other.  
The actual cooking time will change based on rice volume, water temperature, water volume and others for about 10 minutes. Please take the cooking time as the estimated time.  
(When cooking conditions include 220V voltage and 23°C room temperature and water temperature and water volume is adjusted to the standard value)
- Please reduce rice volume to cook porridge.  
Please do not add water higher than the maximum water level scale ("2") of "Congee"
- 18-minute quick cook: 1-2 cups of rice, hot water at least 70°C, cooking time about 18 minutes;  
Ordinary quick cook: If no hot water is added or when cooking more than 2 cups of rice, it automatically switches to ordinary quick cook and the cooking time is 25-35 minutes
- ※ Please refer to "MIXED RICE" on page 12 for the proportion of mixed rice. It is recommended to use the large measuring cup when cooking more than 1 cup of mixed rice.
- ※ Tips:  
The default cooking time is 30 minutes. The displayed time is the time required from water boiling to cooking end, not the time required for the cooking; for food that is difficult to cook, it is recommended to add water and cook again; for easily cooked food, take out the food according to personal taste preference after cooking for an appropriate time.
- ※ "Capacity" water level: Indicates the water capacity of the inner pot, but it is still recommended not to exceed the maximum water level of congee when cooking congee/soup.
- ※ Eco indicator: 1. When entering the keep-warm state, the keep-warm indicator and the Eco indicator will turn on at the same time; 2. If there is no operation in 5 minutes, the cooker will enter Eco state automatically, the screen turns off, and only the Eco indicator stays on.

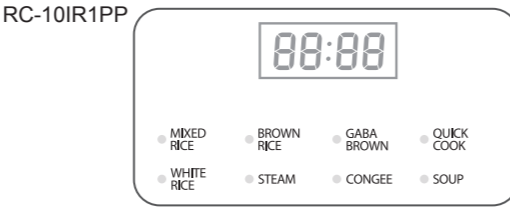

## Usage and setting of MENU

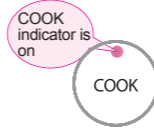
Function selection method	
<b>1</b> Press 	<p>Each time when you press the MENU button, the option light will flash and change in the order of                      &lt;MIXED RICE&gt; → &lt;GABA BROWN&gt; → &lt;QUICK COOK&gt; → &lt;WHITE RICE&gt; → &lt;STEAM&gt; → &lt;CONGEE&gt; → &lt;SOUP&gt; .</p>
	
<b>2</b> Press 	<p>♪ Beep once                      ♪ Beep four times —</p>
	

## Usage and setting of HEALTHY RICE

**1** Press 

Press this shortcut button to enter the cooking process. There is no need to press the COOK button.

- The cooking time is automatically adjusted according to the rice amount (default is 40 minutes).



※ Preparation steps:

1. Put the cleaned rice on the bottom of the healthy rice basket and place them in the inner pot.
2. Add water according to the amount of rice to the healthy rice water level of the healthy rice basket (refer to the actual cooker for the water level line).
3. Close the lid, press HEALTHY RICE, select the amount of rice, and press COOK to start cooking.

※ Note:

1. When using the healthy rice function, the amount of rice should not exceed the maximum scale marked by the water level line of the healthy rice basket;
2. The healthy rice basket has through holes and it is rice soup in the bottom. It is normal if the bottom of the rice is wet;
3. When cooking healthy rice, do not choose any function other than HEALTHY RICE, or else it will cause failure.



### Notice

- If the cooked rice is soft, please reduce the amount of water according to your preference.
- When using the timer cooking function, the starch of the rice will settle, so the rice at the bottom may have a light yellow-brown color. This phenomenon can be alleviated by thoroughly washing the rice.
- When the room temperature and water temperature are low or when there is a lot of water, the cooking time may be delayed by about 10 minutes.

### At work When you want to check the current time

Press during work  or 



When pressed only, the current time will be displayed

### How to adjust the current time (clock)

Clock is displayed in 24 hours  
(12 p.m....0:00 / 12 a.m....12:00)

**1** Insert the power plug, press and hold  for more than 2 seconds

The time display will flash.

**2**   are used to adjust the time (Hour) (minute)

When it is pressed continuously, the time will be adjusted by minute.

**3** Press COOK or wait for 5 seconds without pressing any button to stop adjustment. Press the CANCEL button to exit the setting. The flashing of the display stops.

- The clock can't be adjusted during cooking, keeping warm or timer cooking.
- The operation sound during time adjustment is as follows.

00:00 ..... ♪ Bi Lo Lo  
 12:00 ..... ♪ Bi Lo Lo, Bi Lo Lo  
 Every 10 minutes: ♪ Bi—(no sound when fast forwarding)  
 Every 1 hour ... ♪ Bi Bi

# Method of presetting cooking time



Complete cooking within the preset time.

Preparation	<p><b>Confirm whether it fits with the current time</b></p> <ul style="list-style-type: none"> <li>● If it does not fit with the current time, it is impossible to finish cooking within the preset time.</li> </ul>
	<p><b>Wash rice, add or reduce water, place inner cooking pot in the body and place on the upper housing</b></p> <ul style="list-style-type: none"> <li>● It is impossible to pre-set without inner cooking pot in.</li> </ul>
Operation	<p><b>1</b> Press  <b>Change of appointment time</b></p> <ul style="list-style-type: none"> <li>● Press down the Pre-setting (Timer) button.</li> </ul>
	<p><b>2</b>  Hour <b>Set the time for finishing cooking</b>  Minute</p> <ul style="list-style-type: none"> <li>● Set with every hour or every 10 minutes as a unit.</li> <li>● Continue to press the return and forward button for fast forward.</li> <li>※ Cooking will promptly start for appointment within about 1-2 hours.</li> </ul> <p>The electric cooker will memorize the appointment time. Therefore, the operation may be omitted if the same appointment time is used for cooking the next time.</p>
	<p><b>3</b> <b>Confirm the cooking mode</b></p> <ul style="list-style-type: none"> <li>● Select cooking type, and set cooking mode.</li> </ul> <p> Setting.</p> <p><b>! Please set the cooking mode to &lt;Congee&gt; during porridge cooking.</b> ( Using other cooking modes ) may cause spill or scald</p>
	<p><b>4</b> Press  <b>Appointment completed</b></p> <p>There will be a prompt voice if the <b>START</b> (cook) button is not pressed down. (The appointment setting is not complete)</p> <ul style="list-style-type: none"> <li>● START light turns on after cooking is started. (It is on until cooking is done)</li> <li>● It displays the time left before completing cooking after starting the cooking.</li> </ul> <p>➔ <b>Cooking is completed at the appointment time</b></p>
<p>To cancel appointment or operation is wrong Press </p>	

## Pay attention that

■ "X" indicates on cooking appointment does not work during cooking appointment (It may cause rice deterioration or corrosion to inner cooking pot)

MIXED RICE	BROWN RICE	GABA BROWN	QUICK COOK	WHITE RICE
○	○	○	X	○

STEAM	CONGEE	SOUP	HEALTHY RICE
○	○	○	○

■ If the rice cooker has a lithium battery and can display the time, please make sure that the cooker time is the local time before setting the timer. Press "H r." to enter clock adjustment mode. Then press "Hr." "Min." to adjust the time and set the timer. For quick functions, first press the Timer button, set the time, and then press the shortcut button to activate the cooking timer.

■ **Please do not make appointment longer than 14 hours** (Please do not exceed 8 hours in summer) Long-time appointment will make the rice fermented or scented.

■ When selecting the timer function, you can press the [MENU] button to select a menu, and then press the [TIMER] button to enter the setting. You can also press the [TIMER] button and then press the [MENU] button to select the function. By default, the selection starts from [MIXED RICE]. If you press the [MENU] button to select a function that can't be reserved, it will start from [MIXED RICE] by default when you press the [TIMER] button. HEALTHY RICE timer setting method: Press the [TIMER] button, and then press the [HEALTHY RICE] button to enter the timer mode.

# Recipes

## GABA brown rice

- 1 Wash the sproutable rice (organic sugar rice, etc.) and put it into the inner pot, add water to the corresponding level (recommended maximum amount of rice is 5 cups of organic brown rice).
- 2 Select GABA BROWN and press COOK to enter the cooking state. The cooking time is about 4 hours (including about 3 hours of germ growth time and 1 hour of cooking time; it is recommended to use the timer function at weekends).



### Use fully active sprouted brown rice

- Choose sproutable sprouted sugar rice as ingredients (also known as "organic brown rice"): After dehulling, a few shell tissues are retained, such as cortex, aleurone layer and germ.
- Choose high-quality brown rice for germinated raw rice. The sprouts of new rice of current year have a survival period of 1 year. A complete and energetic seed must be 100% alive. The germ retention rate reaches 80%.

### Cooking tips (below)

- Soak the organic sugar rice in warm water of 35-40°C in advance to achieve better germination effect; you can also skip the soaking and cook directly.
- Odors (organic acids, esters, etc.) will be produced when organic sugar rice is soaked (germinated). The water needs to be changed every 4 hours.

## Mixed rice

### Ingredients (2~3 servings)

White rice .....	150g
Black rice, oat, millet .....	150g
Water, appropriate amount	



- 1 Wash the prepared white rice and the coarse grain and add them to the inner pot.
- 2 Add water to mark 2 of the MIXED RICE according to the amount of rice
- 3 Select MIXED RICE and press COOK to enter the cooking state.
- 4 After the function is over, open the lid and stir the mixed rice evenly.

Note: It is not necessary to soak in advance when cooking mixed rice. However, you can soak it for about 2~3 hours in advance if you like a softer taste.

# Keep Warm

It will automatically change to the heat preservation mode after cooking.

- To keep the rice tasty during heat preservation, it will automatically control the heat preservation temperature based on using conditions.
- Press down **CANCEL** button to stop the heat preservation. **KEEP WARM** light turns off, and the display content is switched to the current time)
- Take out the inner cooking pot to automatically cut off the heat preservation.

Please note that during heat preservation,

- Please do not leave serving spatula in the pot (It will send out unpleasant odor)
- Please do not keep cold rice in for heat preservation (It will send out unpleasant odor)
- Please do not turn off keep warm function when there is rice in the pot (It will send out unpleasant odor)
- Do not keep warm for more than 8 hours (or else it will produce unpleasant odor)

Start heat preservation from the closing state

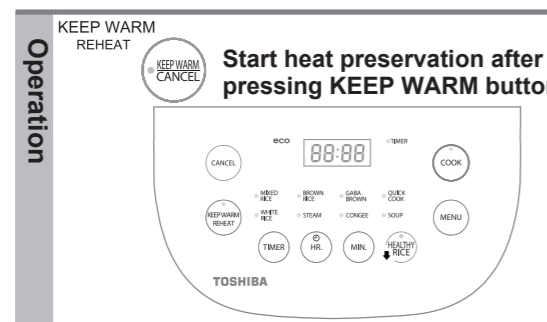

● **KEEP WARM** light turns on

Warm preserving To check the current time

Press during heat preservation



It will display the current time after just pressing down

Tricks for heat preservation

- To prevent rice in heat preservation from being sticky, please do not leave rice grains on side of the inner cooking pot. Besides, please frequently stir the rice.
- It's better to stock in refrigeration with cling film if "the heat preservation may be too long" or "there is a little rice".

# Maintenance

**Please note** Failing to wash clean will send out unpleasant odor. Therefore, please keep it clean.

## Note

**During maintenance, the power plug should be unplugged. The body should be maintained after cooling.**

Otherwise, it will cause scald

**Please do not use the following items**(Otherwise, it will cause deformation, corrosion, discoloration, crack or scratch)

- Tableware washing dryer and tableware dryer
- Detergent other than neutral detergents for kitchen
- Gasoline, thinner, alcohol, cleanser and bleach
- Grinding surface of nylon pot-scouring brush, melamine sponge and other items easily causing scratch

**After using inner cooking pot, removable cover plate, steam valve and serving spatula and measuring cup getting dirty every time**

Wash with sponge and neutral detergent for kitchen Wash the removable cover plate promptly after adding seasoning for cooking. Otherwise, it will get rusty.

## Body • Main temperature controller

**Wipe off foreign matters or dirt with dried duster cloth**

- Please do not wash the entire body.
- Please do not spray water to operating parts or covers, or add water into the outer casing cover.
- Please do not pull or drag washer of steam vent. (Impossible to fall down due to fixing)

**When there is dirt on temperature sensor**

Slightly friction with fine sandpaper (about No.600), and then wipe off dirt with dried clean duster cloth.

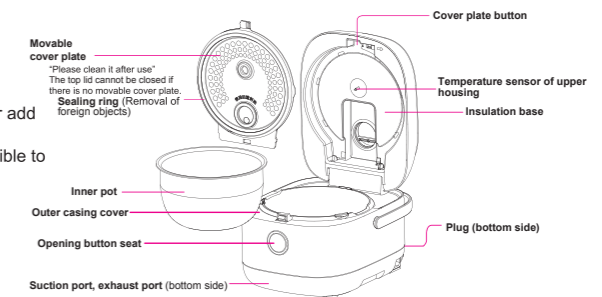

## Opening buckle plate, suction port and exhaust port (bottom of the body)

Clean up foreign matters or dusts with cotton rod or others.

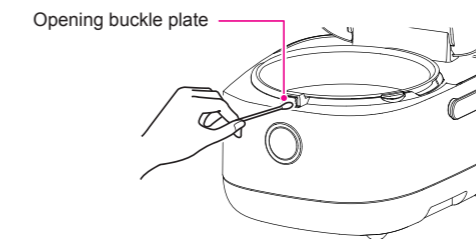

Suction port and exhaust port

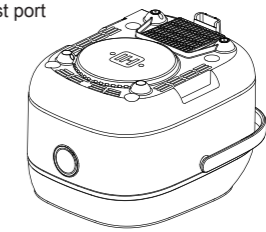

## Steam valve

Clean inside steam valve

Wipe off water after using every time

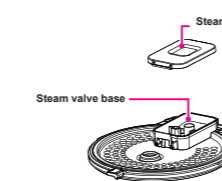

- Dirt in steam valve will cause rice scent and spill. Besides, there may be water drops in the case of spilling or opening the upper housing.
- There will be water generated from cooled steam inside steam valve. If any water, there may be water drops when opening upper housing. (Since water in steam valve is hot after using, maintain after the body is cooled down)
- Refer to page 8 for the method of disassembly.

## Movable cover plate

Clean inside steam valve

Clean up attached foreign matters with bamboo stick or toothpick

- Sealing ring cannot fall off due to fixing.

**Cleaned by boiling (about once a week)** If any unpleasant odor detected, please use this method for cleaning

**1 Place water in inner cooking pot and close the outer cover.**

(To 1 in the water level scale of "White Rice")

**2 Select < QUICK COOK > and press < COOK >**

it will take 35 minutes when switch to keep warm function.

**3 Press CANCEL button after converting to heat preservation state, maintain removable cover plate, steam valve, inner cooking pot and other parts and dry them up after the body is cooling.**

- Please do not place in any items other than water (detergent, etc.).
- Please do not continuously clean by boiling.
- Some unpleasant odor may not be completely removed.

### About inner cooking pot

**Please do not put the inner cooking pot on the gas stove to burn it, or put it on the induction cooker or in the microwave oven.**

It may cause deformation, discoloration or faults.

**Please do not bump against the inner cooking pot or drop it on a hard substance.**

It may cause damage and deformation on the outside of the inner cooking pot.

**Please do not damage the fluororesin coating on the inner surface of the inner cooking pot.**

Otherwise, the fluororesin coating will be split from the inner surface of the inner cooking pot.

**To prevent scratch or falling of "fluororesin coating" on inner side of the inner cooking pot, please don't do the following items**

**Please pay attention to scratch, salt, acid and detergent**

- Please do not place tableware in the inner cooking pot as a cleaning bucket.
- Please do not use scrubbing brush and tableware cleaning dryer for cleaning.
- Please do not use cleanser, bleach or others for washing. (Neutral detergent for kitchen is allowed)



Fluororesin surface may show irregular color as time goes on, which, however, will not cause influence to cooking, heat preservation performance or sanitation. Please use at ease. Besides, even though fluororesin enters human body, it will not cause any influence to health.

※ Even though the coating outside inner cooking pot is scratched, there is no problem in terms of cooking and heat preservation and it can still be normally used.

In the case of using inner cooking pot for rice washing, padding with a duster cloth below the pot makes it uneasy to scratch bottom outside the inner cooking pot.

## How to deal with cooking failure

Please check before applying for repair. If the reason cannot be found out after investigation, please consult with the store where you buy the electric cooker.

This time		Investigate the reasons (reference page)
Rice	Soft In pasty state Lump sump Not tasty	<ul style="list-style-type: none"> <li>● Please reduce water volume for cooking.</li> <li>● Please scarify the rice completely and promptly after the cooking is done.</li> <li>● Please reduce water volume for cooking in the case of using new rice.</li> <li>● Soaking rice or making appointment for cooking before cooking will make the cooked rice soft.</li> <li>● Roughly rubbing the rice during washing or drying out with shallow basket will rip off rice and make the rice in pasty state.</li> <li>● Whether hot water or alkaline ionized water of pH value above 9 is used?</li> </ul>
	Hard Loose Not tasty	<ul style="list-style-type: none"> <li>● Please increase water volume for cooking.</li> <li>● Please soak the rice in advance before cooking.</li> <li>● Whether mineral water of higher hardness is used?</li> </ul>
	Burnt ※ Slight burnt of fawn is not faulty.	<p><b>It can easily get burnt in the following conditions.</b></p> <ul style="list-style-type: none"> <li>● Inadequate rice washing.</li> <li>● Long soaking time. Cooking appointment.</li> <li>● Cooking washing-free rice. Cleaning for 1-2 times can relieve the coking situation.</li> <li>● Cook milled rice with embryo or soup rice, and adding seasoning.</li> <li>● Where there is dirt or foreign matters on temperature sensor or temperature sensor on upper housing.</li> </ul>
	Badly cooked Not tasty	<ul style="list-style-type: none"> <li>● Whether cooking is operated when the inner cooking pot slot or removable cover plate is not cooled down? Please cool down them before cooking.</li> <li>● Rice cooked under the &lt;QUICK COOK&gt; mode will be softer or harder.</li> <li>● Whether the removable cover plate is blocked with foreign matters, and whether there is foreign matter attached to temperature sensor of upper housing, main temperature controller, sealing ring, edge of inner cooking pot and suction port/exhaust port?</li> <li>● Whether inner cooking pot or removable cover plate is deformed? Whether the inner cover or steam vent is uninstalled?</li> <li>● Whether the power is cut off during cooking?</li> </ul>
Rice in heat preservation	With unpleasant odor ※ If any unpleasant odor, please be sure to clean by boiling, and use after cleaning and maintenance. (Page 23)	<ul style="list-style-type: none"> <li>● <b>Whether the following heat preservation is done?</b> Long-time heat preservation, heat preservation of cold rice, heat preservation with serving spatula in pot and repeated long-time heat preservation.</li> <li>● Heat preservation is suitable for coarse food grain rice, polished rice and germinant brown rice. However, compared with white rice, their scent or color can be easily changed. It is recommended to use up quickly or store in refrigeration.</li> <li>● Whether there is dirt on removable cover plate, steam valve and body? Especially for the removable cover plate and steam valve, please take off to clean after cooking every time, and wipe off water.</li> <li>● Whether rice is not fully washed or long-time appointed cooking is selected?</li> <li>● Whether the rice is still left in pot after cutting off the heat preservation? Take out the inner cooking pot and place it back during heat preservation, and press OFF button, and cut off power supply due to long-time power outage.</li> </ul>
	Half-cold rice	<ul style="list-style-type: none"> <li>● Please reheat before eating.</li> </ul>
	Pasty	<ul style="list-style-type: none"> <li>● Please reduce water volume for cooking and then heat preservation.</li> <li>● Please scarify the rice completely and promptly after the cooking is done.</li> <li>● Please place rice together to prevent rice grains from being left on side of inner cooking pot, and frequently stir the rice.</li> </ul>
	Drying and discoloration	<ul style="list-style-type: none"> <li>● Whether there are foreign matters attached on sealing ring, edge of inner cooking pot and outer casing cover?</li> <li>● Whether there are foreign matters attached on outside of inner cooking pot and the main temperature controller?</li> <li>● Whether steam valve has been indeed installed well?</li> <li>● Whether long-time heat preservation or reheating is repeated?</li> </ul>

	This time	Investigate the reasons (reference page)
Switch on upper housing	Difficult to close Impossible to close	<ul style="list-style-type: none"> <li>Whether the removable cover plate has been installed well? If the removable cover plate is not installed, the upper housing cannot be closed to prevent forgetting the installation of the removable cover plate.</li> <li>Whether the plug-in part under the removable cover plate is plugged in?</li> <li>Whether there are foreign matters attached on opening buckle plate?</li> <li>Whether the removable cover plate is blocked with foreign matters?</li> </ul>
	Open upper housing during cooking	<ul style="list-style-type: none"> <li>Please press the central part on the front side of upper housing until a sound of "clatter".</li> <li>Whether there are foreign matters attached on opening buckle plate?</li> </ul>
Preset	Promptly start cooking Fail to cook at the appointed time Fail to make appointment	<ul style="list-style-type: none"> <li>Cooking will promptly start for appointment within 1-2 hours.</li> <li>Whether the a.m. and p.m. are confused? The clock is of 24-hour display mode.</li> <li>Whether the current time is wrong?</li> <li>Whether lithium batteries are run down?</li> <li>If the room temperature and water temperature are lower or water volume is larger, cooking finishing time may be delayed for about 10 minutes.</li> <li>Whether inner cooking pot is installed before presetting appointment time?</li> <li>Whether the appointment is not set or the COOK button is not pressed?</li> </ul>
Cooking and heat preservation	Steam leakage ※ Please confirm after finishing cooking.	<ul style="list-style-type: none"> <li>Whether there are foreign matters attached on sealing ring, edge of inner cooking pot and outer casing cover?</li> <li>Whether there are foreign matters attached on upper housing and opening buckle plate?</li> <li>Whether the sealing ring is damaged and whether inner cover or inner cooking pot is deformed?</li> <li>Whether the removable cover plate is installed?</li> </ul>
	There are water drops nearby exhaust nozzle of steam valve	<ul style="list-style-type: none"> <li>Steam will be converted to water drops attached after cooling. Not failure.</li> </ul>
	Water drops on removable cover plate and inner cooking pot	<ul style="list-style-type: none"> <li>To prevent rice from getting dry, there may be water drops attached to the removable cover plate and inner cooking pot, and this is not a failure.</li> </ul>
	There are condensed water dropped from sealing ring and other parts after opening upper housing	<ul style="list-style-type: none"> <li>Sometimes, condensed water will drop on outer casing cover and other parts based on the time, room temperature and other conditions when the upper housing is opened. Please wipe them off.</li> <li>Condensed water will flow into inner cooking pot (rice), rather than into frame when the cover is not completely opened or is slightly opened with hands.</li> <li>In case of cutting off heat preservation or pulling out power plug with rice in, removable cover plate will cause condensation and there will be much condensed water attached.</li> <li>Whether there are foreign matters attached on the main temperature controller and outside inner cooking pot?</li> </ul>
	Spilling	<ul style="list-style-type: none"> <li>Whether there is very little rice or very much water, or rice is washed inadequately?</li> <li>Is the porridge cooking mode right?</li> <li>Whether there are foreign matters attached on temperature sensor on the upper housing and main temperature controller?</li> <li>Whether there is dirt inside steam valve?</li> <li>Whether steam valve and removable cover plate is installed well?</li> <li>Whether the removable cover plate is blocked with foreign matters?</li> </ul>
	Thin film generated inside inner cooking pot	<ul style="list-style-type: none"> <li>Sticky rice paper-shaped thin film is the dried dissolved sugar (starchiness) in rice, which is not a fault.</li> </ul>
	Fail to press button for operation	<ul style="list-style-type: none"> <li>Whether the power plug is plugged in? Whether the inner cooking pot is well placed?</li> </ul>
Display-Button	The light goes out It stops halfway	<ul style="list-style-type: none"> <li>Pressing OFF/CANCEL button by mistake or long-time power outage will cut off the power.</li> </ul>
	Displayed residual time is different from the actual cooking time	<ul style="list-style-type: none"> <li>Sometimes, there may be difference with the actual cooking time, which is not a fault. Please refer to the "About display of cooking time" for detsa.il</li> </ul>

## How to deal with cooking failure

Please check before applying for repair.

	This time	Investigate the reasons (reference page)
Ese	It sends out sound during use	<ul style="list-style-type: none"> <li>Please refer to the "Sound in use" on Page 9.</li> </ul>
	With scent of plastic and others	<ul style="list-style-type: none"> <li>When starting to use, there may be an odor, which will gradually disappear with the use. Eliminate the unpleasant odor by ventilating and cleaning by boiling.</li> </ul>
	Some parts on plastic spare parts are presented in linear or wave shape	<ul style="list-style-type: none"> <li>It is track of plastic, which is not a fault. It does not influence cooking or heat preservation.</li> </ul>
	There is a gap between upper housing and body	<ul style="list-style-type: none"> <li>There will be gap more or less between upper housing and body, but the machine is closed with the sealing ring.</li> </ul>
	There is the scratch or dirt on coating outside the inner cooking pot	<ul style="list-style-type: none"> <li>As the using time increases, there will be scratch or dirt on coating on the outer side of the inner cooking pot, which, however, will not influence cooking and heat preservation, and the pot can be normally used.</li> </ul>
Tripping of circuit breaker during cooking	<ul style="list-style-type: none"> <li>In the case of being used together with other electric products, sometimes it may exceed the rated current of the circuit breaker. Please use a separate power socket.</li> </ul>	

## Error display

Please check the causes once again for the COO error

Please pull out power plug (on the power supply side) from the socket, and dispose with the following method.

02	<ul style="list-style-type: none"> <li>Please clean up dust on suction port and exhaust port at bottom of the body.</li> <li>Please do not place the electric cooker on paper, cloth, blanket, plastic bag or other soft items and use it in places where suction port and exhaust port can be easily blocked.</li> </ul>	<p><b>Restarting</b></p> <p>Connect to power cords after treatment.</p> <p>Press  (Remove fault display)</p> <p>↓</p> <p>Please re-start after the inner cooking pot slot, inner cooking pot and inner cover are cooled down.</p>
04	<ul style="list-style-type: none"> <li>Please check whether there is an inner cooking pot or whether a non-dedicated inner cooking pot is used? → Please place the dedicated inner cooking pot in electric cooker.</li> </ul>	
E1~E6, EU	<ul style="list-style-type: none"> <li>Fault display of circuit board and sensor. Please promptly stop using, pull out power plug and consult with retailers selling this product.</li> </ul>	

### When there is the power outage

#### Continue the cooking or heat preservation after electrifying.

However, there may appear poor cooking, power supply cut-off, delay of appointed finishing time and other conditions.

※ It is the same as the condition when the power plug is pulled out halfway or circuit breaker trips.

### Lithium batteries

The lithium batteries fixed in the body are used to drive the clock and memorize the cooking mode when pulling out power plugs.

#### Lithium batteries are run down

Display disappears after the power plug is pulled out and it is impossible to memorize the time and cooking mode.

**Insert power plug into socket, 12:00 will flicker after all lights turn on, and the cooker can be used as usual. (During cooking appointment, please adjust the clock to the current time before using)**

→ Please consult with the store where you buy the electric cooker while changing batteries. (Charged)

Batteries are fixed in the body, and customers cannot replace by themselves.

This time

# Specifications

Model	Voltage frequency	Consumption power (Cooking)	Consumption power (Keep Warm)	Rated Capacity	Max. Cooking Capacity (rice volume)	Dimension (Unit: cm)			Body Weight	Power cord length
						Length	Width	Height		
RC-10IR1PP	230V~60Hz	1000W	Average 20W	3.0L	1L	31.5	24.2	22.0	5.1kg	1m

 Warm check	Check electric cookers which have been used frequently in many years!	Please use under regularly confirming of "Important Safety Instructions" and "Notes". Wrong using method and long-time use will deteriorate spare parts due to influence from heat, moist, dust and others, with the possible hidden danger and fault.
	<b>Whether there is such symptom?</b> Please clean up dust on power plug or power socket.	<ul style="list-style-type: none"> <li>● Abnormal heating of power plug or power cord.</li> <li>● The body gives off scorched flavor.</li> <li>● Part of the body is broken, wry or squeaking.</li> <li>● Deformation or damage of inner cooking pot, outer cover and inner cover</li> <li>● The fan at bottom does not rotate during cooking.</li> <li>● There are other abnormalities or faults.</li> </ul>