

Watson-Marlow qdos

User Manual



Contents

1 Declaration of conformity	5
2 Warranty	6
2.1 Conditions	6
2.2 Exceptions	7
3 When you unpack your pump	8
3.1 Packaging disposal	8
3.2 Inspection	8
3.3 Components supplied	8
3.4 Optional accessories	9
3.5 Storage	9
4 Information for returning pumps	10
5 Safety notes	11
6 Pump specifications	15
6.1 Pump specifications	19
6.2 Standards (AC mains power supply)	20
6.3 Standards (12-24V DC power supply)	20
6.4 Dimensions	21
6.5 Weights	22
7 Materials of construction	23
8 Pumphead materials of construction	25
8.1 ReNu 20, 60 and 120 twin tube pumphead	25
8.2 ReNu 30 pumphead	26
9 Pump installation	27
9.1 Installation instructions	27
9.2 Do's and do not's	28
9.3 Pressure capability	29
9.4 Dry running	29
10 Connecting to a power supply	30
10.1 AC mains power supply	30
10.2 DC power supply option	30
11 Start-up check list	32
12 Automatic control wiring - Universal, Universal+ and Remote models without relay modules	33
12.1 pin assignments at the pump	34
12.2 Optional input lead	34
12.3 Output pin assignments at the pump	35
12.4 Optional output lead	37

13 Automatic control wiring - Relay module (Universal and Universal+ only)	38
13.1 Module: cover removal and refitting	38
13.2 Wiring up the terminal connectors	39
13.3 Relay module pcb connectors	42
14 PROFIBUS control wiring	45
14.1 PROFIBUS installation	45
14.2 Pin assignments at the pump	46
15 Switching on (Manual, PROFIBUS, Universal and Universal+)	47
15.1 Switching on the pump for the first time (Manual, PROFIBUS, Universal and Universal+ only)	47
15.2 Switching the pump on in subsequent power cycles (Manual, PROFIBUS, Universal and Universal+ only)	50
16 Switching on (Remote)	51
17 Pump operation	52
17.1 Pump operation (Remote pump)	52
17.2 Pump operation (Manual, PROFIBUS, Universal and Universal+ only)	52
18 Manual mode (Manual, PROFIBUS, Universal and Universal+ only)	55
19 PROFIBUS mode (PROFIBUS only)	58
19.1 Assigning the PROFIBUS station address at the pump	59
19.2 PROFIBUS communication errors	61
19.3 PROFIBUS GSD file	62
19.4 User Parameter Data	64
19.5 PROFIBUS data exchange	65
19.6 Device-related diagnostic data	68
19.7 Channel-related diagnostic data	68
20 Flow calibration mode (Manual, PROFIBUS, Universal and Universal+ only)	70
21 Analog 4-20mA mode (Universal and Universal+ only)	73
21.1 Calibrate the pump for 4-20mA control (Universal+ only)	78
22 Contact Mode (All Universal and Universal+ models)	83
22.1 Contact settings	83
22.2 Contact operating mode (All Universal and Universal+ models)	85
22.3 Fluid recovery mode (Manual, PROFIBUS, Universal and Universal+ only)	86
22.4 Remote fluid recovery (Universal and Universal+ models without relay modules)	88
23 Main menu (Manual, PROFIBUS, Universal and Universal+ only)	90
23.1 Fluid level monitor (Manual, PROFIBUS, Universal and Universal+ only)	91
23.2 Security settings (Manual, PROFIBUS, Universal and Universal+ only)	95
23.3 General settings (Manual, PROFIBUS, Universal and Universal+ only)	98
23.4 MODE menu (Manual, PROFIBUS, Universal and Universal+ only)	103

23.5 Control settings (Manual, PROFIBUS, Universal and Universal+ only)	104
23.6 Help (Manual, PROFIBUS, Universal and Universal+ only)	111
24 Status LEDs (Remote only)	112
25 Troubleshooting	113
25.1 Leak detection	113
25.2 Pumphead Alert (qdos20, ReNu 20 PU only)	114
25.3 Error codes	114
25.4 Error Indication (Remote only)	115
26 Technical support	116
27 Drive maintenance	117
28 Pumphead Replacement (qdos 30)	118
28.1 Connecting interface tubing	121
29 Pumphead Replacement (qdos 20, 60, 120 and CWT)	125
29.1 Connecting interface tubing	129
30 Ordering information	132
30.1 Pump part numbers	132
30.2 Spares and accessories	133
31 Performance data	137
31.1 Pumping conditions	137
31.2 Pressure capability	137
31.3 Dry running	137
31.4 Pumphead life	137
31.5 DC power supply option - input characteristics	137
31.6 Performance curves	139
32 Trademarks	141
33 Publication history	142

1 Declaration of conformity



Watson-Marlow Ltd
Falmouth
Cornwall
TR11 4RU
England



EC Declaration of Conformity

1. **Qdos20, Qdos 30, Qdos 60, Qdos 120:** Manual, Remote, Universal, Universal+, Profibus, Universal Relay and Universal+ Relay
2. Manufacturer:
WATSON MARLOW LTD
BICKLANDS WATER ROAD
FALMOUTH
UK
TR11 4RU
3. This declaration of conformity is issued under the sole responsibility of the manufacturer.
4. All models and versions of the Qdos series of peristaltic pumps with all approved pump heads, and accessories.
5. The object of the declaration described above is in conformity with the relevant Union harmonisation legislation:
Machinery Directive 2006/42/EC
EMC Directive 2014/30/EU
ROHS Directive 2011/65/EU
6. Harmonised standards used:
BS EN61010-1:2010 Safety requirements for electrical equipment for measurement, control, and laboratory use Part 1: General requirements EN61326-1:2013
Electrical equipment for measurement, control and laboratory use –
EMC requirements Part 1: General requirements BS EN 60529:1992+A2:2013
Degrees of protection provided by enclosures (IP code)
7. Intertek Testing and Certification Ltd, No:3050250, performed compliance testing to BS EN 61010-1:2010, IEC 61010-1:2010 , UL 61010-1:2010 and CAN/CSA C22.2 Bo 61010-1:2010 and issued a certification of compliance to these standards, number: 100716552LHD-003
Signed for and on behalf of:
Watson-Marlow Ltd.
Falmouth, 14.11.2019

Simon Nicholson, Managing Director



This pump is ETL listed: ETL control number 3050250. Cert to CAN/CSA std C22.2 No 61010-1. Conforms to UL std 61010A-1.

See "Pump specifications" on page 15.

2 Warranty

Watson-Marlow Limited ("Watson-Marlow") warrants this product to be free from defects in materials and workmanship for three years from the date of shipment, under normal use and service.

Watson-Marlow's sole responsibility and the customer's exclusive remedy for any claim arising out of the purchase of any product from Watson-Marlow is, at Watson Marlow's option: repair, replacement or credit, where applicable.

Unless otherwise agreed in writing, the foregoing warranty is limited to the country in which the product is sold.

No employee, agent or representative of Watson-Marlow has the authority to bind Watson-Marlow to any warranty other than the foregoing unless in writing and signed by a director of Watson-Marlow. Watson-Marlow makes no warranty of the fitness of its products for a particular purpose.

In no event:

- i. shall the cost of the customer's exclusive remedy exceed the purchase price of the product;
- ii. shall Watson-Marlow be liable for any special, indirect, incidental, consequential, or exemplary damages, however arising, even if Watson-Marlow has been advised of the possibility of such damages.

Watson-Marlow shall not be liable for any loss, damage, or expense directly or indirectly related to or arising out of the use of its products, including damage or injury caused to other products, machinery, buildings, or property. Watson-Marlow shall not be liable for consequential damages, including, without limitation, lost profits, loss of time, inconvenience, loss of product being pumped, and loss of production.

This warranty does not obligate Watson-Marlow to bear any costs of removal, installation, transportation, or other charges which may arise in connection with a warranty claim.

Watson-Marlow shall not be responsible for shipping damage of returned items.

2.1 Conditions

- Products must be returned by pre-arrangement to Watson-Marlow, or a Watson-Marlow approved service centre.
- All repairs or modifications must have been made by Watson-Marlow Limited, or a Watson-Marlow approved service centre or with the express permission in writing of Watson-Marlow, signed by a manager or director of Watson-Marlow.
- Any remote control or system connections must be made in accordance to Watson-Marlow recommendations.
- All PROFIBUS systems must be installed or certified by a PROFIBUS approved installation engineer.

2.2 Exceptions

- Consumable items including tubing and pumping elements are excluded.
- Pumphead rollers are excluded.
- Repairs or service necessitated by normal wear and tear or by lack of reasonable and proper maintenance are excluded.
- Products which, in the judgement of Watson-Marlow, have been abused, misused, or subjected to malicious or accidental damage or neglect are excluded.
- Failure caused by electrical surge is excluded.
- Failure caused by incorrect or sub-standard system wiring is excluded.
- Damage by chemical attack is excluded.
- Ancillaries such as leak detectors are excluded.
- Failure caused by UV light or direct sunlight.
- All ReNu pumpheads are excluded.
- Any attempt to disassemble a Watson-Marlow product will invalidate the product warranty.

Watson-Marlow reserves the right to amend these terms and conditions at any time.

3 When you unpack your pump

Unpack all parts carefully, retaining the packaging until you are sure all components are present and in good order. Check against the components supplied list, below.

3.1 Packaging disposal

Dispose of packaging materials safely, and in accordance with regulations in your area. The outer carton is made of corrugated cardboard and can be recycled.

3.2 Inspection

Check that all components are present. Inspect components for damage in transit. If anything is missing or damaged, contact your distributor immediately.

3.3 Components supplied

Qdos 20, 60, 120 and CWT:



Note: Pumpheads may vary in appearance

Qdos 30:



Note: The appearance of the pump drive unit may vary from the that shown depending on the pump model. The hydraulic connector pack shown is an optional accessory.

The following components are supplied with all qdos pumps:

- Pump drive unit
- ReNu pumphead
- User connection collars
- The designated power cable (attached to the pump drive unit)
- CD-ROM containing these operating instructions
- Quick start manual
- Product safety information booklet

The qdos120 is also supplied with two off 1/2" polypropylene hose barb connectors.

3.4 Optional accessories

Spares and accessories are available such as:

- Additional ReNu pumphead
- HMI protective cover (not compatible with remote models)
- Interface tubing
- Input and output (I/O) leads
- Hydraulic connector packs

For a full list of accessories see "Spares and accessories" on page 133.

3.5 Storage

This product has an extended shelf life. However, care should be taken after storage to ensure that all parts function correctly. Please observe the storage recommendations and use-by dates which apply to ReNu pumpheads and tubing you may wish to bring into service after storage.

4 Information for returning pumps

Before returning products, they must be thoroughly cleaned/decontaminated. The declaration confirming this should be completed and returned to us in advance of the item being shipped.

You are required to complete and return a decontamination declaration stating all fluids that have been in contact with the equipment being returned to us.

On receipt of the declaration, we will issue a Returns Authorisation Number. We reserve the right to quarantine or refuse any equipment that is not displaying a Returns Authorisation Number.

Please complete a separate decontamination declaration for each product and use the correct form that denotes the location you wish to return the equipment to.

A copy of the appropriate decontamination declaration can be downloaded from the Watson-Marlow website at www.wmftg.com/decon

If you have any queries then please contact your local Watson-Marlow representative for further assistance at www.wmftg.com/contact.

5 Safety notes

In the interests of safety, this pump and pumphead should only be used by competent, suitably trained personnel after they have read and understood this manual, and considered any hazard involved. If the pump is used in a manner not specified by Watson-Marlow Limited, the protection provided by the pump may be impaired.

Any person who is involved in the installation or maintenance of this equipment should be fully competent to carry out the work. In the UK this person should also be familiar with the Health and Safety at Work Act 1974.



This symbol, used on the pump and in this manual, means: Risk of explosion.



This symbol, used on the pump and in this manual, means: Caution, refer to accompanying documents.



This symbol, used on the pump and in this manual, means: Do not allow fingers to contact moving parts.



This symbol, used on the pump and in this manual, means: Caution, hot surface.



Fundamental work with regard to lifting, transportation, installation, starting-up, maintenance and repair should be performed by qualified personnel only. The unit must be isolated from mains power while work is being carried out. The motor must be secured against accidental start-up.



There is a non-replaceable fuse on the switch-mode power supply board. In some countries, the mains power plug contains a replaceable fuse. There are no user-serviceable fuses or parts inside this pump.



This pump must be used only for its intended purpose.

The pump must be accessible at all times to facilitate operation and maintenance. Access points must not be obstructed or blocked. Do not fit any devices to the drive unit other than those tested and approved by Watson-Marlow. Doing so could lead to injury to persons or damage to property for which no liability can be accepted.

If hazardous fluids are to be pumped, safety procedures specific to the particular fluid and application must be put in place to protect against injury to persons.



This product does not comply with the ATEX directive and must not be used in explosive atmospheres.



The pump must be bolted to a flat, horizontal, rigid surface, free from excessive vibration, to ensure correct lubrication of the gearbox and correct pumphead operation. Allow a free flow of air around the pump to ensure that heat can be dissipated. Ensure that the ambient temperature around the pump does not exceed 45C (113F).



If pumping flammable liquids, a full risk assessment should be completed prior to use.



The exterior surfaces of the pump may get hot during operation. Do not take hold of the pump while it is running. Allow the pump to cool after use before handling. The drive unit must not be run without a pumphead fitted. The pumphead should not be run dry for extended periods of time. The pump should not be used to pump fluids where the temperature of the fluid can reach temperatures of more than 70°C.



Ensure the chemicals to be pumped are compatible with the pumphead, lubricant, tubing, pipework and fittings to be used with the pump. Please refer to the chemical compatibility guide which can be found at: www.wmftg.com/gb-en/range/watson-marlow/chemical-metering/. If you need to use the pump with any other chemical please contact Watson-Marlow to confirm compatibility

Operation of the pump after failure of the consumable peristaltic tube may result in a flow of chemicals to the inside of the pumphead. Some aggressive chemicals are not compatible with the pumphead materials. These aggressive chemicals will react to the materials internal to the pumphead and may cause leaks.

In the worst case, chemicals could leak out from the pumphead and attack the drive shaft and lip seal, damaging the seal integrity. Damage to the seal could cause aggressive chemicals to enter the pump housing and react with the components internal to the pump housing. The reaction may produce explosive gases inside the pump housing.

Danger of damage to pump and possible risk of explosion, if process chemical has entered the pump housing.

The pump housing contains aluminium components which can react with some chemicals to produce explosive gas.



In the event of tube failure the pump should be isolated from both electrical and hydraulic supplies. Immediately remove the ReNu pumphead and check the drive shaft for signs of chemical residue. If chemical is found contact your local service centre. Do not connect the pump to mains power until you have consulted with the service centre!

For instruction on pumphead replacement see "Pumphead Replacement (qdos 30)" on page 118 or "Pumphead Replacement (qdos 20, 60, 120 and CWT)" on page 125.

To prevent dosing liquid entering the pump housing follow the recommended actions below.

To prevent damage to the pump and pumphead due to failure of the consumable peristaltic tube:

- change the pumphead shortly after failure or when recommended to do so by the pumps pumphead management system
- do not use the 'ignore' function as a long term solution to a failed pumphead. Approved use of the Ignore function: In order to de-pressurise and drain down the system and to allow for the safe disposal of the pumphead, the ignore function can be used to operate the pump prior to changing the pumphead. This is the **ONLY** approved use of the IGNORE function. Option removed in later models.
- install a non return valve in the discharge line close to the pump when pumping against a positive pressure. This will prevent a constant stream of chemical flowing back into the pumphead after failure. Flow area of at least 50mm² is recommended for the valve. Do not go below 50mm² flow area / 8mm inner bore on the outlet side for water-like fluids.
- isolate the main power supply to the pump. Isolation devices can be controlled using the leak detection alarm signal
- do not disable the pump leak detection system
- change the pumphead prior to failure when pumping very aggressive chemicals that are not compatible with the pumphead materials. There are volume and hours counters in the product to provide indication of consumable life.

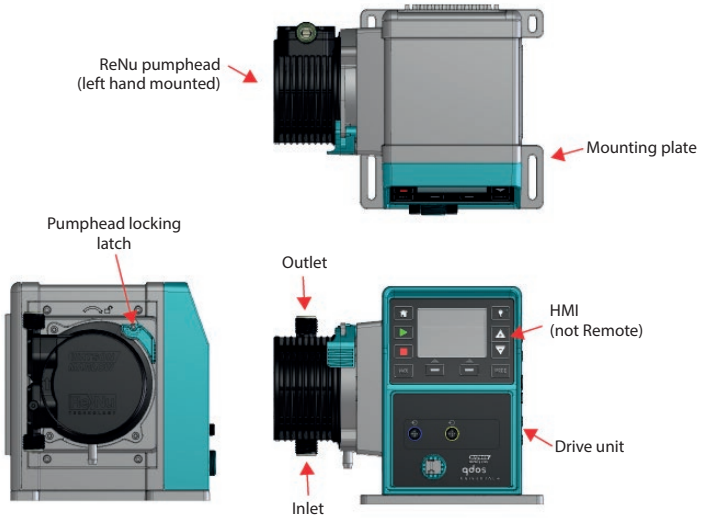
Qdos 20 only:

- ensure the correct tube type is selected within the configuration of the pump. This can be checked at any time after commissioning by entering the CONTROL SETTINGS via the MENU softkey.
- ReNu PU Pumphead only: when replacing a pumphead prior to the recommended lifespan of the tube or before a tube failure, once the pump has been powered-down, pumphead replaced and power restored, select 'pumphead selection' within the Control Settings accessed by pressing the MENU soft key.

6 Pump specifications

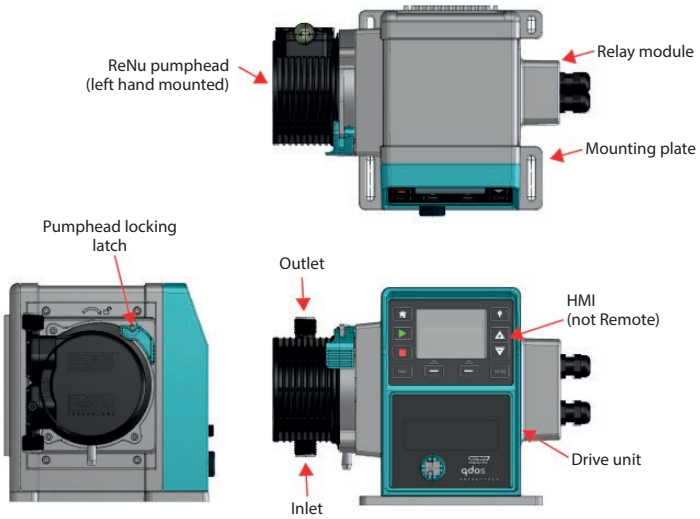
qdos 20, 60, 120 and CWT:

The ReNu CWT pumphead will vary in appearance from the ReNu 20, 60 and 120 pumpheads (pictured)

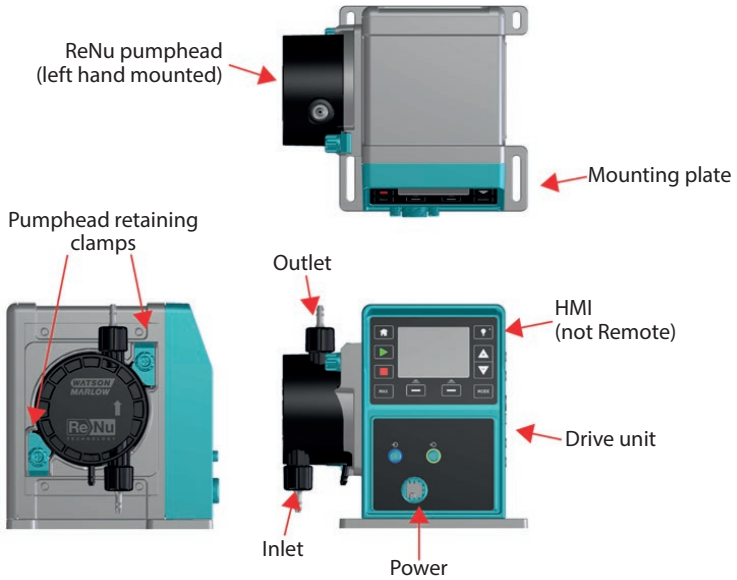


qdos 20, 60, 120 and CWT with relay module:

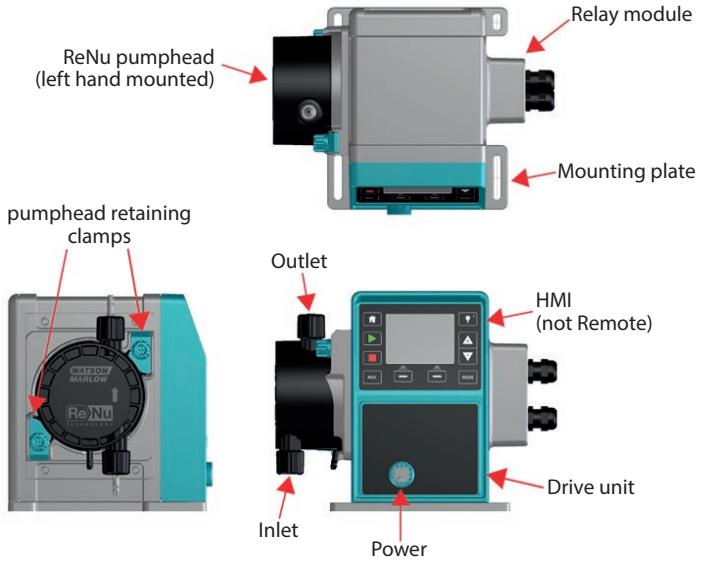
The ReNu CWT pumphead will vary in appearance from the ReNu 20, 60 and 120 pumpheads (pictured)



qdos 30:



qdos 30 with relay module:



A nameplate is fixed to the rear of the pump. It contains manufacturer and contact details, product reference number, serial number and model details.



Manufacturer details

Product reference

Model

Serial number

6.1 Pump specifications

<p>Flow Range (flow control)</p>	<p>Manual, PROFIBUS, Universal and Universal+:</p> <p>qdos120:0.1-2000 ml/min (20000:1) qdos60:0.1-1000 ml/min (10000:1) qdos30:0.1-500 ml/min (5000:1) qdos20:0.1-333 ml/min (3330:1) qdos20 PU: 0.1-484 ml/min (4840:1) qdos CWT: 0.1-500 ml/min (5000:1)</p> <p>Remote:</p> <p>qdos120:1.25-2000 ml/min (1600:1) qdos60:0.6-1000 ml/min (1600:1) qdos30:0.3-500 ml/min (1600:1) qdos20:0.2-333 ml/min (1600:1) qdos CWT: 0.3-500 ml/min (1600:1)</p>
<p>AC Supply voltage/frequency</p>	<p>~100-240V 50/60Hz</p>
<p>AC Power consumption</p>	<p>190VA</p>
<p>DC Supply voltage (12/24VDC power option)</p>	<p>12-24V DC</p>
<p>DC Power consumption (12/24VDC power option)</p>	<p>150W</p>
<p>Installation category (overvoltage category)</p>	<p>II</p>
<p>±10% of nominal voltage. Maximum voltage fluctuation</p>	<p>An electrical mains supply is required along with cable connections to the best practice of noise immunity</p>
<p>Enclosure rating</p>	<p>IP66 to BS EN 60529 NEMA 4X to NEMA 250*</p>
<p>Operating temperature range</p>	<p>4°C to 45°C, 41°F to 113°F</p>
<p>Storage temperature range</p>	<p>-20°C to 70°C, -4°F to 158°F</p>
<p>Maximum altitude</p>	<p>2,000m, 6,560ft</p>
<p>Humidity (non-condensing)</p>	<p>80% up to 31°C, 88°F, decreasing linearly to 50% at 40°C, 104°F</p>
<p>Pollution degree</p>	<p>2</p>

Noise

<70dB(A) at 1m

*Requires the fitting of the HMI protective cover.

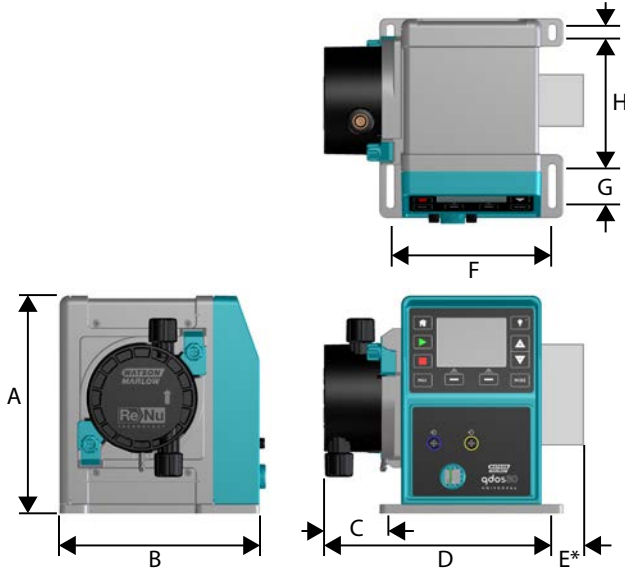
6.2 Standards (AC mains power supply)

EC Harmonised standards	Safety requirements for electrical equipment for measurement, control and laboratory use: BS EN 61010- 1 incorporating A2 Category 2, Pollution degree 2
	Degrees of protection provided by enclosures (IP code): BS EN 60529 amendments 1 and 2
	EN61326-1:2006 Electrical Equipment for measurement control and laboratory use EMC requirements Part 1
Other Standards	UL 61010A-1, UL/CSA 61010-1
	CAN/CSA-C22.2 No 61010-1
	IEC 61010-1
	Radiated emissions FCC 47CFR, Part 15
	NEMA 4X to NEMA 250
	NSF61 for pumphead

6.3 Standards (12-24V DC power supply)

EC Harmonised standards	Safety requirements for electrical equipment for measurement, control and laboratory use: BS EN 61010- 1 incorporating A2 Category 2, Pollution degree 2
	Degrees of protection provided by enclosures (IP code): BS EN 60529 amendments 1 and 2
	EN61326-1:2006 Electrical Equipment for measurement control and laboratory use EMC requirements Part 1
Other Standards	UL 61010A-1, UL/CSA 61010-1
	CAN/CSA-C22.2 No 61010-1
	IEC 61010-1
	Radiated/conducted emissions FCC 47CFR, Part 15
	NEMA 4X to NEMA 250
	NSF61 for pumphead

6.4 Dimensions



Dimension	qdos20	qdos30	qdos60	qdos120	qdos CWT
A	234mm (9.2")	234mm (9.2")	234mm (9.2")	234mm (9.2")	234mm (9.2")
B	214mm (8.4")	214mm (8.4")	214mm (8.4")	214mm (8.4")	214mm (8.4")
C	104.8mm (4.1")	71.5mm (2.8")	104.8mm (4.1")	104.8mm (4.1")	117.9mm (4.6")
D	266mm (10.5")	233mm (9.2")	266mm (10.5")	266mm (10.5")	290.9mm (11.5")
E*—Optional relay modules	43mm (1.7")	43mm (1.7")	43mm (1.7")	43mm (1.7")	43mm (1.7")
F	173mm (6.8")	173mm (6.8")	173mm (6.8")	173mm (6.8")	173mm (6.8")
G	40mm (1.6")	40mm (1.6")	40mm (1.6")	40mm (1.6")	40mm (1.6")
H	140mm (5.5")	140mm (5.5")	140mm (5.5")	140mm (5.5")	140mm (5.5")
I	10mm (0.4")	10mm (0.4")	10mm (0.4")	10mm (0.4")	10mm (0.4")

6.5 Weights

qdos20, 60 and 120:

Model	Drive		Drive with pumphead		Drive CWT with pumphead	
	kg	lb	kg	lb	kg	lb
Manual	4.6	10lb 2oz	5.7	12lb 9oz	6.8	15lb 0oz
Remote	4.5	9lb 15oz	5.6	12lb 6oz	6.7	14lb 13oz
Universal	4.6	10lb 2oz	5.7	12lb 9oz	6.8	15lb 0oz
Universal+	4.6	10lb 2oz	5.7	12lb 9oz	6.8	15lb 0oz
PROFIBUS	4.6	10lb 2oz	5.7	12lb 9oz	6.8	15lb 0oz
Universal 24V relay	4.8	10lb 9oz	5.9	13lb 0oz	7	15lb 7oz
Universal+ 24V relay	4.8	10lb 9oz	5.9	13lb 0oz	7	15lb 7oz
Universal 110V relay	4.8	10lb 9oz	5.9	13lb 0oz	7	15lb 7oz
Universal+ 110V relay	4.8	10lb 9oz	5.9	13lb 0oz	7	15lb 7oz

qdos30:

Model	Drive		Drive with pumphead	
	kg	lb	kg	lb
Manual	4.1	9lb	5.05	11lb 2oz
Remote	4.0	8lb 13oz	4.95	10lb 15oz
Universal	4.1	9lb	5.05	11lb 2oz
Universal+	4.1	9lb	5.05	11lb 2oz
PROFIBUS	4.1	9lb	5.05	11lb 2oz
Universal 24V relay	4.3	9lb 8oz	5.25	11lb 9oz
Universal+ 24V relay	4.3	9lb 8oz	5.25	11lb 9oz
Universal 110V relay	4.3	9lb 8oz	5.25	11lb 9oz
Universal+ 110V relay	4.3	9lb 8oz	5.25	11lb 9oz

7 Materials of construction

qdos 20, 60 and 120:

for qdos 30 and CWT see "qdos 30 and CWT:" on the next page

Component	Material		
	qdos 20	qdos 60	qdos 120
Keypad	Polyester		
Drive casework	20% Glass filled PPE/ PS		
Drive shaft	Stainless steel 440C		
Pumphead enclosure	30% Glass filled PPO/PS		
Rotor	PP (qdos 20 PU) / Glass filled nylon	Glass filled nylon	
Rotor bearings	Steel, stainless steel (optional—contact Watson-Marlow applications)		
Tube*	PU (max 4 bar, 60 psi) / SEBS (max 7 bar, 60 psi)	Santoprene (max 7 bar, 100 psi) / SEBS (max 4 bar, 60 psi)	
Membrane*	N/A		
Pumphead hydraulic ports	PVDF (SEBS or PU)	Polypropylene (Santoprene) or PVDF (SEBS)	Polypropylene (Santoprene)
Hydraulic connectors	Polypropylene (standard) PVDF (optional)		
Lubricant*	PFPE based		

*It is the user's responsibility to comply with local health and safety regulations, including ensuring chemical compatibility between the duty fluid, the tube and lubricant contained in the ReNu Pumphead. For guidance refer to www.qdospumps.com.

qdos 30 and CWT:

Component	Material	
	qdos 30	qdos CWT
Keypad	Polyester	
Drive casework	20% Glass filled PPE/ PS	
Drive shaft	Stainless steel 440C	
Pumphead enclosure	40% Glass filled PPS	
Rotor	Glass filled nylon	Stainless steel
Rotor bearings	Steel, stainless steel (optional—contact Watson-Marlow applications)	
Tube*	Santoprene (max 7 bar, 100 psi) / SEBS (max 4 bar, 60 psi)	N/A
Membrane*	N/A	EPDM
Pumphead hydraulic ports	Polypropylene (Santoprene) or PVDF (SEBS)	Polypropylene (Santoprene) or PVDF (SEBS)
Hydraulic connectors	Polypropylene (standard) PVDF (optional)	
Lubricant*	PFPE based	

*It is the user’s responsibility to comply with local health and safety regulations, including ensuring chemical compatibility between the duty fluid, the tube and lubricant contained in the ReNu Pumphead. For guidance refer to www.qdospumps.com.

8 Pumphead materials of construction

Materials of construction that have the potential of being wetted when the tube fails.

8.1 ReNu 20, 60 and 120 twin tube pumphead

Part Number	Description	Material of Construction
CT0060M	Qdos 60 baffle	Acetal homopolymer (POM-H)
CT0074M	Qdos 60 rotor baffle	
OS0071	Shaft seal 18x30x5	Nitrile (NBR)
Various	Various sized o-rings	
CT0082M	Qdos 60 rear	Noryl FE1630PW 30% glass filled (PPE+PS GF30)
CT0144M	Qdos 60 PRV screw body	
CT0145M	Qdos 60 PRV valve body	
CT00146M	Qdos 60 PRV valve seat	
CT00108T	Machined track	
CT0109M	Qdos 60 rotor	Nylon 6 30% glass bead (PA6 GB30)
CT0057M	Qdos 60 window	Polycarbonate (PC)
Various	Track inserts	Polypropylene homopolymer (PPH)
CT0168T	RuNu 20 PU rotor (ReNu 20 PU only)	
CT0053T	Rotor collar	Stainless steel 316
SG0036	Spring	
BB0061	Ball bearing 30x55x13	Steel and rubber
CT0058M	Rubber overmould seal	TPE

8.2 ReNu 30 pumphead

Part Number	Description	Material of Construction
CT0075T	Qdos 30 Relief piston	Acetal copolymer (POM-H)
SG0034	Spring	Carbon steel
CT0001T	Qdos 30 Track Machined	Fortron 1140L4 40% glass filled (PPS GF40)
Various	Various sized o-rings	Nitrile (NBR)
OS0071	Shaft seal 18x30x5	
CT0002M	ReNu 30 Rotor	Nylon 6 30% glass bead (PA6 GB30)
CT0011M	Renu 30 Middle Plate	
CT0044M	ReNu rear window	Polycarbonate (PC)
CT0012M	Qdos 30 Venting Piston	Polypropylene
CT0005M	ReNu 30 Rear Cover	Polypropylene 20% glass filled
CT0006M	Qdos 30 Tube End Fitting	Polypropylene copolymer (PPC)
SG0030	Spring	Stainless steel 316
CT0046T	Rotor collar	
BB0061	Ball bearing 30x55x13	Steel and rubber
CT0015M	Rubber overmould seal	TPE

9 Pump installation

9.1 Installation instructions



Always consult an expert before installing a metering pump in a specialised system. Metering pumps should be maintained by qualified persons.



The pump must be bolted to a flat, horizontal, rigid surface, free from excessive vibration, to ensure correct lubrication of the gearbox and correct pumphead operation. Allow a free flow of air around the pump to ensure that heat can be dissipated. Ensure that the ambient temperature around the pump does not exceed 45C (113F).

The STOP key on pumps supplied with a keypad will always stop the pump. However, it is recommended that a suitable local emergency stop device is fitted into the mains supply to the pump.

Do not stack pumps.

This pump is self-priming and self-sealing against backflow. No valves are required in inlet or discharge lines, except as described below. Valves in the process flow must be opened before the pump operates.



Users must fit a non-return valve between the pump and the discharge pipework to avoid the sudden release of pressurised fluid in the event of a pumphead failure. This shall be fitted immediately after the discharge of the pump.



qdos is a positive displacement pump; therefore, it is recommended best practice that customers incorporate discharge pressure relief in their piping system. Failure to fit a pressure release valve in the discharge pipework will result in excessive build up of pressure should the discharge become blocked. This may present a safety risk, may cause damage to the system pipework or lead to premature failure of the pumphead. The pressure relief valve shall be rated at no more than 10bar. It shall always be rated at below the users system maximum operating pressure. It shall be installed so as to provide easy access for maintenance, inspection and repair. It shall not be capable of being adjusted without the use of a tool. The discharge opening must be located and directed so that the release material is not directed towards any person and will not deposit on parts that could cause a hazard. There must not be a shut-off valve between the overpressure safety device and the pump.



Do not block the drain port of the ReNu pumphead.

ReNu 20, ReNu 60 or ReNu 120



IMPORTANT: Set the pressure valve to the 'in-use' position before installing the pumphead.

In 'Transportation position' Leak detector will not function with discharge pressure below 1 bar (15 psi).



Ensure the chemicals to be pumped are compatible with the pumphead and the pipework and fittings to be used with the pump. Please refer to the chemical compatibility guide which can be found at: www.wmftg.com/gb-en/range/watson-marlow/chemical-metering/. If you need to use the pump with any other chemical please contact Watson-Marlow to confirm compatibility.

9.2 Do's and do not's

Do operate the pumphead with the pressure switch in the 'in use' position—(Qdos20,60 & 120 only).

Do remove and replace a ReNu pumphead immediately after a tube failure and leak detect signal from the pump.

Do keep delivery and suction tubes as short and direct as possible - though ideally not shorter than one metre - and follow the straightest route. Use bends of large radius: at least four times the tubing diameter. Ensure that connecting pipework and fittings are suitably rated to handle the predicted pipeline pressure. Avoid pipe reducers and lengths of smaller bore tubing than the pumphead section, particularly in pipelines on the suction side. Any valves in the pipeline must not restrict the flow. Any valves in the flow line must be open when the pump is running.

Do use a proprietary non-return valve in the discharge line of the pump.

Do use an over-pressure/ pressure relief valve within the process line as described in "Installation instructions" on the previous page.

Do use suction and delivery pipes with the largest diameter bore tube that will fit with your process, especially when pumping viscous product. Care should be taken when pumping solids in suspension as large bore tubes will reduce the fluid velocity, this may lead to solids dropping out of suspension.

Do site the pump at or just below the level of the fluid to be pumped if possible. This will ensure flooded suction and maximum pumping efficiency.

Do run at slow speed when pumping viscous fluids. Flooded suction will enhance pumping performance, particularly for materials of a viscous nature.

Do recalibrate after changing pumphead, fluid, or any connecting pipework. It is also recommended that the pump is recalibrated periodically to maintain accuracy.

Do ensure your PROFIBUS pump is installed in accordance with PROFIBUS installation guidelines.

Do clean any process fluid from the drive in order to maintain normal operation of the leak detect system.

Do check that replacing a pumphead clears a leak detect alert.

Do change the pumphead shortly after failure, this ensures fluid containment is retained.

Do avoid tight bends in the PROFIBUS signal cable.

Do check the drive shaft for visible signs of any chemical when replacing an expired pumphead for a new pumphead. If chemical residue is found report this to your local service centre. Carefully read safety notes and instructions in "Pumphead Replacement (qdos 30)" on page 118 and "Pumphead Replacement (qdos 20, 60, 120 and CWT)" on page 125.

Do not build a pump into a tight location without adequate airflow around the pump.

Do not pump any chemical not compatible with the pumphead.

Do not tilt the drive with a pumphead fitted, even if it is not running.

Do not allow process fluid to leak onto the drive during pumphead replacement.

Do not use the ignore function as a long term solution to a failed pumphead, prolonged exposure to process fluid may result in the loss of fluid containment resulting in drive or process area contamination. The only approved use of the Ignore function: In order to depressurise and drain down the system and to allow for the safe disposal of the pumphead, the ignore function can be used to operate the pump prior to changing the pumphead—Only applicable for pumps manufactured up until October 2019.

Do not strap the control and mains cable together.

qdos20 only:

Do select the correct tube type when asked.

Do replace the pumphead when recommended to do so by the pumphead management system.

Do Select 'pumphead selection' and 'PU pumphead' within the control panel setting if changing pumphead prior to pumphead failure.

Do not reinstall the used pumphead once the pumphead management system recommends the pumphead to be replaced.

9.3 Pressure capability

qdos120 can be operated continuously at discharge pressures of up to 4 bar (60psi)

qdos20, qdos30, qdos60 and qdos CWT can be operated continuously at discharge pressures of up to 7 bar (100psi).

qdos30 can be operated at discharge pressures of up to 10 bar (145psi), however flowrate and pumphead life will be affected.

qdos20 PU can be operated continuously at discharge pressure of up to 4 bar (60psi)

9.4 Dry running

qdos will continue to operate when there is gas present in the suction line and will maintain prime in these conditions. The pump can be run dry, however flow rate and pumphead life will be affected.

10 Connecting to a power supply

10.1 AC mains power supply

This pump is fitted with a switch mode power supply and will operate from any mains voltage in the range ~100-240V AC, 50/60Hz supplies.

Make suitable connection to an earthed, single-phase mains electricity supply.



We recommend using commercially available supply voltage surge suppression where electrical noise may be present.

Power cable: The pump is supplied fitted with a cable gland and approximately 2.8m (9.2ft) of power cable. The cable is not user-detachable and the entry gland at the front of the pump should not be disassembled.

Each pump is supplied with a power cable. The connector at the pump end of the cable is IP66 rated. The mains plug at the opposite end of the cable is NOT IP66 rated.



Ensure that all power supply cables are adequately rated for the equipment.



The pump must be positioned so that the disconnection device (the mains plug), is easily accessible when the equipment is in use.



For pumps with a metal motor shaft Earth continuity can be tested with a DMM in resistance mode (<100hms), do not perform a PAT tester earth continuity test on the motor shaft as high current will damage the motor bearing.

10.2 DC power supply option

The range of DC sources is intended to include:

- Automotive—either mobile, such as trailer mounted, or static, such as a vehicle battery or auxiliary output
- Conventional DC supplies derived from AC mains, such as 12V or 24V supplies powering PLCs
- Solar panels with any type of back-up battery within the input range
- Other renewable energy generators such as wind/hydro turbines with any type of back up battery within the input range

Power cable: The pump is supplied fitted with a cable gland and approximately 2.0m (6.6ft) of power cable and an IP31 splash proof blade fuse holder and 20A blade fuse. The cable is not user-detachable and the entry gland at the front of the pump should not be disassembled.

Installation instructions

It is highly recommended that an isolating switch is provided between the power source and the pump. The cable is fitted with M8 ring terminals to fit common isolators.

The 20A blade fuse is a safety device and should not be removed or the value changed.

The fuse holder is splashproof (IP31) but NOT waterproof (IP66). Connection to the DC source should be provided with appropriate IP protection.

Large start up currents may be required, especially at low voltages, see "Performance data" on page 137 for correct selection of power source.

We **DO NOT** recommend increasing the cable length when used in 12V systems due to extra voltage loss in the cable. Increasing cable length will also invalidate the pumps EMC compliance and require the user to perform their own system level EMC compliance check.

11 Start-up check list

- Check that the leak detect sensor is clean and free from process fluid.
- Fit the pumphead to the drive. (See "Pumphead Replacement (qdos 30)" on page 118 or "Pumphead Replacement (qdos 20, 60, 120 and CWT)" on page 125).
- Ensure the pumphead ports are securely fitted to the interface tubing.
- Ensure proper connection has been made to a suitable power supply.
- Ensure that the general recommendations are followed (see "Installation instructions" on page 27).
- **When using a ReNu 20 PU pumphead**, ensure you select the 'PU' tube to apply the correct calibration values.

12 Automatic control wiring - Universal, Universal+ and Remote models without relay modules

Interfacing the pump with other devices is by means of two IP66 rated five pole M12 connectors mounted on the front of the pump. M12 connectors with flying lead cables can be purchased as an accessory from Watson-Marlow. The function of each of the leads is labelled.



It is the user's responsibility to ensure the safe and reliable operation of the pump under remote and automatic control.

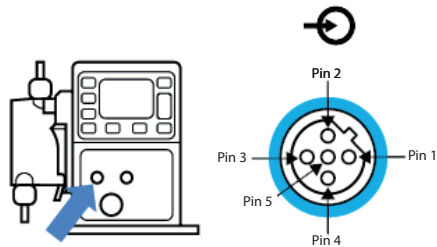


Never apply mains power to the five pole M12 connectors. Apply the correct signals to the pins, as shown below. Limit signals to the maximum values shown. Do not apply voltage across other terminals. Permanent damage may result.



All input and output terminals are separated from mains circuits by reinforced insulation. These terminals must only be connected to external circuits that are also separated from mains voltages by reinforced insulation as a minimum requirement.

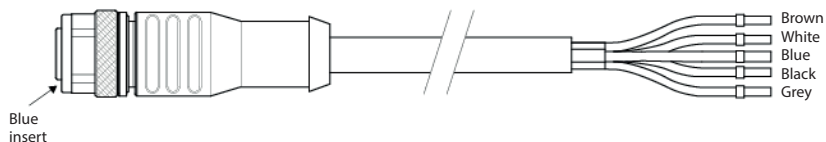
12.1 pin assignments at the pump



Pin No.	Function	Specification	Referenced to	Input lead colour
1	Run/stop	Min. 5V, max.30V	Connect 5-24V DC supply to stop (referenced to pin 4). Alternatively, connect pin 5 of the output connector to this pin via normally open switch.	Brown
2	External Contact Reserved	Min. 5V, max .30V	Pulse 5-24V 40ms minimum pulse length (referenced to pin 4). Alternatively, connect pin 5 of the output to this pin via normally open switch.	White
3	4-20mA	250Ω input impedance 40mA max. current 250Ω load resistance 40mA max.current	Referenced to GND	Blue
4	GND	Ground (0V)		Black
5	Remote fluid recovery	Min. 5V, max. 30V	Connect 5-24V DC supply to reverse the pump in analog mode	Grey

12.2 Optional input lead

Input lead length: 3m (10ft)



Remote stop

Depending on the polarity set in the control settings menu, applying a 5V to 24V signal to pin 1 will STOP the pump in all operating modes. In manual and analogue mode, the pump will start when the signal is removed. The user can reconfigure this input in the control settings menu so that the pump will run when the signal is applied and stop when there is no signal to pin 1.

The MAX key will work in manual mode regardless of the remote STOP input. This enables priming without having to change pump settings or disconnect the input cable.

External contact—Universal and Universal+ models only

Digital pulse input min. 5V, min. pulse duration 40mS maximum duration 1000mS. This input is used to trigger a user defined dose size. Refer to the contact mode section.

Speed: analog input

The speed of this pump can be controlled remotely by a current analog signal within the range 4-20mA.

The analog signal must be applied to pin three of the M12 input connector. The pump will provide an increasing speed for a rising control signal.

The Universal+ model can be calibrated by the user to control the speed proportionally or inversely proportional to the input mA signal.

4-20mA circuit impedance: 250Ω.

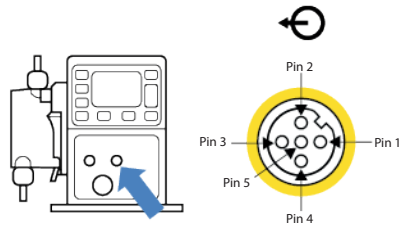


Do not invert the polarity of the terminals. If the polarity is inverted the motor will not run.

Remote fluid recovery

The user can reverse the pump remotely by supplying a signal to pin five.

12.3 Output pin assignments at the pump

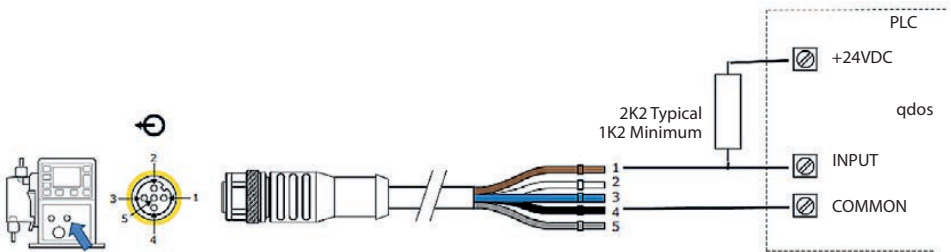


Pin No.	Function	Specification	Output lead colour
1	Run status output	Open collector output uncommitted	Brown
2	Alarm output	Open collector output uncommitted	White

Pin No.	Function	Specification	Output lead colour
3	Analog out	4-20mA into 250Ω (referenced to pin 4)	Blue
4	GND		Black
5	Supply	Pin 5 supply voltage is 5V with impedance of 2.2k, this can be connected via a NO switch to input pin 1 or 2 to power the inputs.	Grey

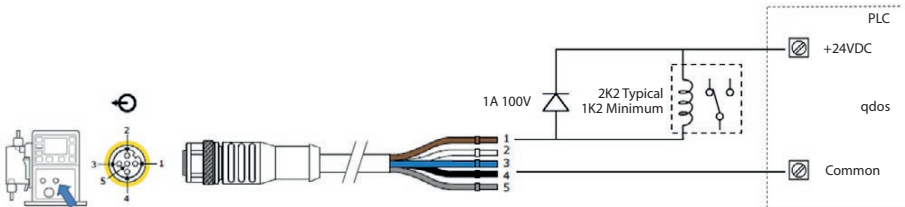
Example wiring for a "pull up resistor"

Diagram depicts either Alarm or Run Stop output.



Example wiring for an external relay, the N/O or N/C contacts could be used for any device

Diagram depicts either Alarm or Run Status output.



The resistor or relay needs to be sized correctly to ensure no damage to the pump transistors. Damage incurred due to incorrect sizing or installation will not be covered by warranty.

These solutions require external 24V power. If connecting to a PLC 24V is usually available.

Alarm Output (Output 1)

Alarm conditions are generated by system errors or leak detection.

Run Status Output (Output 2)

This output changes state when the motor starts/stops.

Speed: analog output—Universal+ and Remote models only

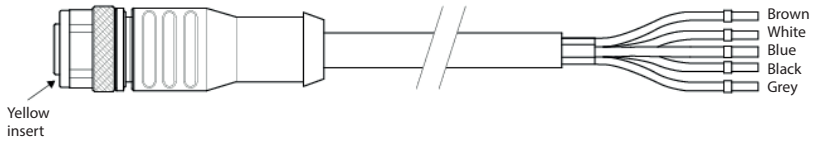
A current analog signal within the range 4-20mA into 250Ω impedance is available between pin three and pin four of the output connector. The current is fixed and directly proportional to the pumphead rotation speed. 4mA = zero speed; 20mA = maximum speed.

On the Universal+ version there is also an option to match the scale of the 4-20mA input if this has been reconfigured by the user. This option is available in the Control settings menu.

Note: If the mA output is to be used for reading from a multimeter, a 250Ω resistor is required in series.

12.4 Optional output lead

Output lead length: 3m (10ft)



13 Automatic control wiring - Relay module (Universal and Universal+ only)

The pump can be connected with other devices by means of the screwless terminals connectors within the relay module situated on the side of the pump. The relay module must be removed from the pump housing to allow suitable cables to be connected to the terminal connectors via the watertight cable glands on the module.

13.1 Module: cover removal and refitting

The pump can be connected with other devices by means of the terminal connectors within the relay module situated on the side of the pump. The relay module cover must be removed from the pump housing to allow suitable cables to be connected to the terminal connectors via the watertight cable glands on the module.

Removing the relay module cover.

The module cover is secured to the side of the drive unit by four M3x10 Pozidriv pan head stainless steel screws.

Remove the four screws from the module cover, leaving the top left screw until last. It is possible that the sealing strip may cause the module to adhere to the drive housing. If so a gentle tap will free it. **Do not** use a tool to force it off.



The sealing strip should be retained within its channel on the side panel of the drive housing. It ensures ingress protection between the drive housing and the module cover. Check the integrity of the sealing strip. If it is damaged it must be replaced.



Refitting the relay module cover.

Ensure the sealing strip is undamaged and positioned within its channel on the side of the drive housing. Hold the module cover in place, taking care not to disturb the sealing strip. Starting with the top left screw, tighten the four retaining screws to 2.5Nm.





Ensure that the relay module cover is correctly secured at all times by all four screws. Failure to do so may compromise the IP66 (NEMA 4X) protection.

13.2 Wiring up the terminal connectors

It is the user's responsibility to ensure the pump's safe and reliable operation under remote and automatic control.

Cable entry to the module is via two watertight cable glands on the module cover. These may be fitted in place of the sealing plugs which are fitted to the side of the module cover when the pump is shipped.

The number of glands needed depends on the number of connection cables required and the convenience of the installer. As standard, two 1/2" cable glands are provided with the pump.

Recommended control cable conductors for the terminal blocks: metric = 0.05-1.31mm², USA = 30-16AWG stranded and solid. Cable: circular. Max/min outside diameter to ensure a seal when passed through the standard gland: 9.5mm-12mm. **The cable section must be circular to ensure a seal.**

For EMC protection, shielded control cable should be used. The shielding should be terminated to any of the provided Earth connections.

Cables should have a minimum temperature rating of 85°C.

Choose cable suitable for the intended application and environment.

More than 8 conductors per cable may be awkward to handle.

1. Use a suitable 21mm spanner to unscrew the sealing plugs.



2. Screw in the supplied 1/2" NPT cable glands complete with new sealing washers in place of the plug, ensuring that the retaining nut is properly seated.



3. Tighten the gland to 2.5Nm using a suitable 21mm spanner, to ensure a seal. If a different gland is used, it must be watertight to IP66.



3. Loosen the gland cap (do not remove it) and pass the cable in through the gland. When it has passed through the gland, continue to push the cable through.
4. Pull through sufficient cable to reach the connectors required, leaving a little slack.
5. Strip the outer sheath as necessary and remove 5mm of insulation from the conductors. No tinning or ferrule is required.



Note: If very stiff or large-diameter cable is used, it may be convenient to strip the outer sheath before passing the cable's conductors through the gland. However, to ensure a watertight seal, the cable must have an undamaged sheath within the gland when it is tightened.

6. Prepare the cable screen(s) by twisting a suitable length. The twisted length(s) shall ideally be sleeved to prevent shorting.
7. Secure the end of the cable screen to the Faston receptacles on the spade connector provided.
8. Push the bared connector into the terminal whilst depressing the sprung button. Release the button to clamp the wire in the terminal.



Avoid loose strands not located in a terminal. These may cause short circuits or electric shock. Bootlace ferrules may be used up to the maximum cable size permitted.

9. When all conductors are in position replace the module cover.
10. Using a 21mm spanner tighten the gland cap to 2.5Nm to ensure a watertight seal. Alternatively, tighten the gland by hand until it is finger-tight and use a spanner to tighten it further by one-half a turn.

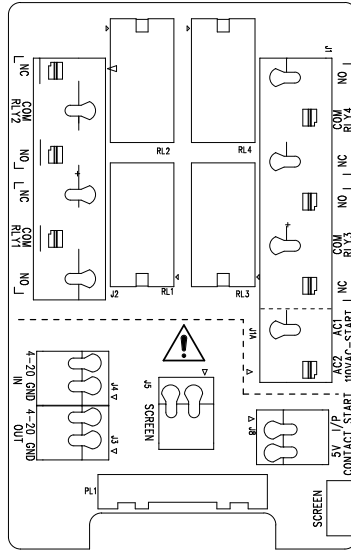


Ensure that unused openings on the module are sealed using the blanking plugs provided. Failure to do so will result in loss of ingress protection.



13.3 Relay module pcb connectors

As you look at the module the pcb will appear in the same orientation as shown in the diagram below.



Never apply mains power to the 4-20mA input, 4-20mA output or stop contact terminals. Apply the correct signals to the terminals shown below. Limit signals to the maximum values shown. Do not apply voltage across other terminals. Permanent damage, not covered by warranty, may result. The maximum load on the relay contacts of this pump is 240VAC 4A or 30VDC 4A.

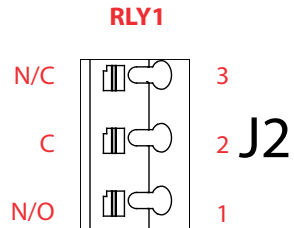
General Alarm output (J2)

Connect the output device to the C (common) terminal of the relay connector and either the N/C (normally closed) or N/O (normally open) terminal as required.

This relay coil is energised when the pump has an alarm condition.

Note: Alarm conditions are generated by system errors. This alarm will not be operated for analogue signal errors.

The default for Relay 1 is General Alarm, on Universal+ models this output (1) can be configured in the control settings menu.

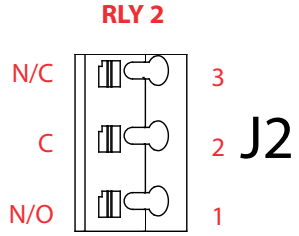


Run status output (J2)

Connect the output device to the C (common) terminal of the relay connector and either the N/C (normally closed) or N/O (normally open) terminal as required.

This relay coil is energised when the pump is running.

The default for output 2 is run status, on Universal+ models this output (2) can be configured in the control settings menu.



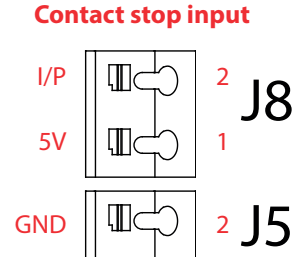
Output 3 and 4

Two additional relay outputs are provided on the Universal+ model of the pump. These outputs are inactive by default, the function of the output must be configured in the control settings menu.

Configurable remote stop or contact input (J8), 24V logic input

If Analog 4-20mA mode is selected then terminal J8 will be configured as a remote stop automatically.

If Contact mode is selected then the input J8 will be configured as a contact input automatically.



Remote stop logic

Connect a remote switch between the **Stop/Contact** terminal and the **5V** terminal of the Run/Stop I/P connector (J8). Alternatively a 5V-24V logic input may be applied to the Stop/Contact terminal, ground to the GND terminal of the adjacent 4-20mA I/P connector (J5).

PLC 24V relay/solenoid driver outputs are not suitable due to the high input impedance of the Stop/Contact terminal.

The sense of the remote stop input can be configured in software using the control settings menu.

Remote stop is operational in manual and analog mode.

Contact

To operate the pump in contact mode the remote stop input should be set to "High".

Remote stop input (J1A), 110V logic

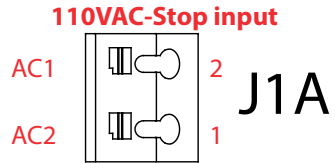
Apply a signal of 85VAC to 130VAC across terminals AC1 and AC2 to stop the pump. Polarity is not important.

In the default condition the pump will not run while this signal is applied. In manual and analog mode, the pump will start when the signal is removed. The input can be configured to act in the opposite way in the control settings menu.

Note: This input is logical OR with the contact dose input.

Contact

If contact mode is enabled the pump will commence a contact dose when an AC input is applied across the terminals.

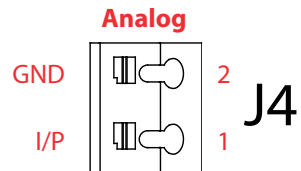


Speed: analog input (J4)

The analog process signal must be applied to the I/P terminal of the Analog connector (J4). Ground to the GND connector of the same terminal. In Analog mode the pump set speed will be proportional or inversely proportional to the analog input.

4-20mA circuit impedance: 250Ω.

Max current 40mA

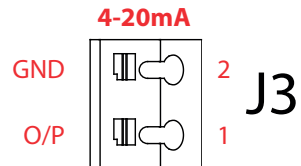


See also "Analog 4-20mA mode (Universal and Universal+ only)" on page 73 and "Calibrate the pump for 4-20mA control (Universal+ only)" on page 78.

Speed: analogue output (J3) (Universal+ only)

A current analogue signal within the range 4-20mA is available between the O/P (output) terminal and the GND terminal. The current is fixed and directly proportional to the pump speed. 20mA = maximum speed, 4mA = zero speed.

There is also an option to match the scale of the 4-20mA input if this has been reconfigured by the user. This option is available in the Control settings menu.



Earth shielding terminals

A 4.8mm spade terminal is supplied for earth shielding of cables. Earth can be connected to the terminal. There are also two spring clamp terminals for additional earth connection.



Keep 4-20mA and low voltage signals separate from mains power. Use separate glanded input cables.

14 PROFIBUS control wiring

Interfacing the pump with the PROFIBUS network is by means of an M12 connector mounted on a flying lead on the front of the pump.



It is the user's responsibility to ensure the safe and reliable operation of the pump under PROFIBUS control.

Note: The transmission speed is limited to a maximum of 1.5Mbit/s.

14.1 PROFIBUS installation

All devices in the bus system must be connected in a line. An IP66 rated T adaptor should be used to connect the pump to the PROFIBUS line. A maximum of 32 stations (to include master, slaves and repeaters) are possible and both the beginning and the end of the cable must be terminated with a terminating resistor.

The M12 socket provided for PROFIBUS installation is IP66 rated. To maintain an IP66 rated system, the PROFIBUS cable, T adaptors and terminating resistors used must be fitted with IP66 rated M12 industrial connectors.

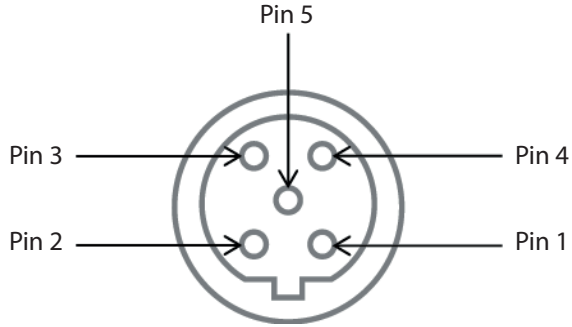
Note: To prevent low-frequency ground loops, screening which is earthed at one end should be used. To counter magnetic HF pick-up, shielding earthed at both ends as well as twisted conductors should be used, this will have no effect against electrical HF pick-up.

The permissible overall length of the bus cabling will vary according to the required bit rate. If a longer cable or higher bit rate are required repeaters should be used. The maximum bit rates achievable are shown in the table below.

Bit rate (Kbit/s)	Max. length of type A bus cable (m)
1500	200
500	400
187.5	1000
93.75	1200
19.2	1200
9.6	1200

Note: Total stub length should not exceed 6.6m.

14.2 Pin assignments at the pump



Pin No.	Signal	Function
1	VP	+5V supply for terminating resistors
2	RxD/TxD-N	Data line minus (A-line)
3	DGND	Data ground
4	RxD/TxD-P	Data line plus (B-line)
5	Shield	Ground connection

Note: If the pump is the last bus device connected to the PROFIBUS cable it must be terminated using terminating resistor (PROFIBUS standard EN 50170). To maintain ingress protection the resistor must be IP66 rated.

15 Switching on (Manual, PROFIBUS, Universal and Universal+)

15.1 Switching on the pump for the first time (Manual, PROFIBUS, Universal and Universal+ only)

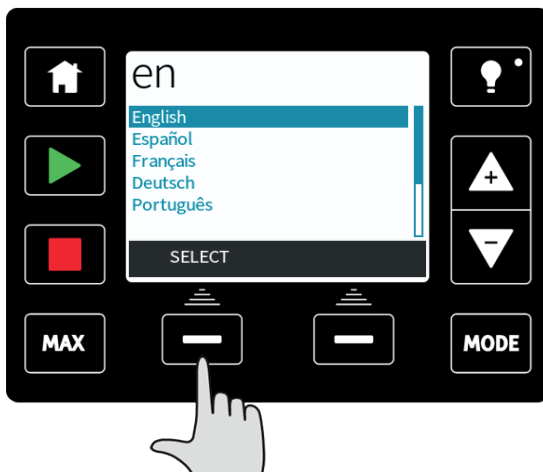
Power-up the pump.

The pump displays the start-up screen with the Watson-Marlow Pumps logo for three seconds.

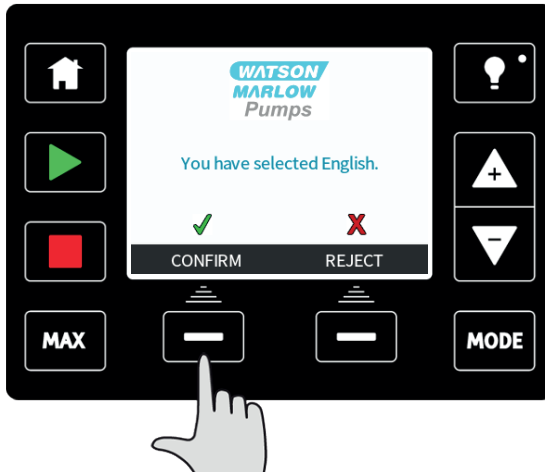


Selecting your chosen display language

Use the +/- keys to move the selection bar to your required language. Press **SELECT** to choose.



Your selected language will now be displayed on screen, choose **CONFIRM** to continue. All displayed text will now appear in your chosen language.

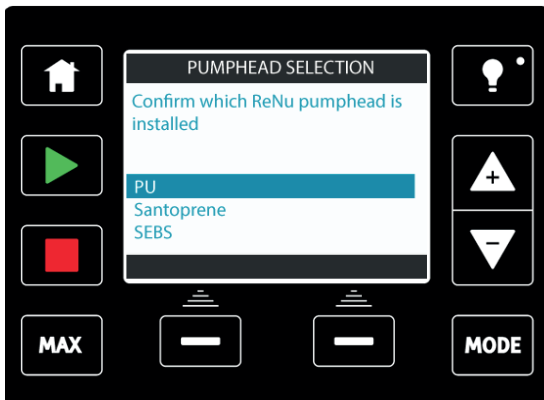


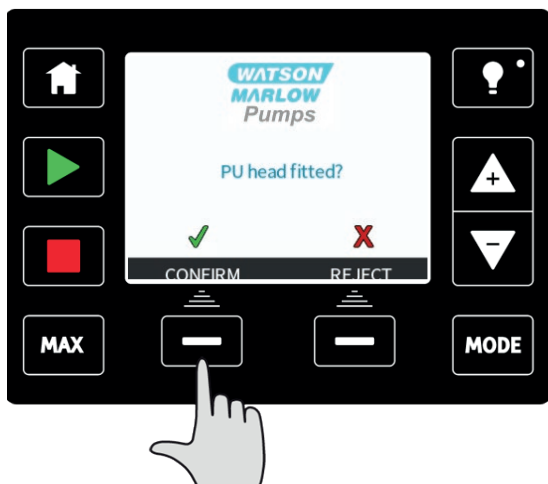
Choose **REJECT** to return to the language choice screen.

The pump is preset with operational parameters as shown in the table below:

Confirm which ReNu pumphead is installed (qdos20 only)

Using the **up/down** arrows select the pumphead installed to the pump. (This will apply correct calibration values)





Choose **REJECT** to return to the pumphead select screen.

The pump is preset with operational parameters as shown in the table below:

First-time start-up defaults

Flow rate	<ul style="list-style-type: none"> qdos120: 960ml/min qdos60: 480ml/min qdos30: 240ml/min qdos20: 120ml/min qdos20 PU: 158.4 ml/min qdos CWT: 300ml/min 	Pump status	Stopped
Calibration	<ul style="list-style-type: none"> qdos120: 16 ml/rev qdos60: 8 ml/rev qdos30: 4 ml/rev qdos20: 6.67 ml/rev qdos20 PU: 8.8ml/rev qdos CWT 4.9ml/rev 	Flow unit	ml/min
Backlight	30 minutes	Pump tag	WATSON-MARLOW
Auto restart	Off		

This then proceeds to the home screen.



The pump is now ready to operate according to the defaults listed above.

Note: The display background colour changes according to running state as follows:

- **White** background indicates pump stopped
- **Blue** background indicates pump running
- **Red** background indicates error or alarm

All operating parameters may be changed by means of key-presses (see "Pump operation" on page 52).

15.2 Switching the pump on in subsequent power cycles (Manual, PROFIBUS, Universal and Universal+ only)

Subsequent power-up sequences will jump from the start-up screen to the home screen.

- The pump runs a power-on test to confirm proper functioning of the memory and hardware. If a fault is found, an error code is displayed (see "Error codes" on page 114).
- The pump displays the start-up screen with the Watson-Marlow Pumps logo for three seconds followed by the home screen.
- Start-up defaults are those in place when the pump was switched off last.

Check that the pump is set to operate as you require it.

The pump is now ready to operate.

All operating parameters may be changed by means of key-presses (see "Pump operation" on page 52).

Power interruption

This pump has an auto restart feature which, when active, will restore the pump to the operating state it was in when power was lost. See "Main menu (Manual, PROFIBUS, Universal and Universal+ only)" on page 90.

Stop / start power cycles

Do not power up/power down for more than **20 starts per hour**, whether manually or by means of the auto restart facility. We recommend remote control where a high frequency of power cycles is required.

16 Switching on (Remote)

When power is supplied to the pump, all the LED icons will illuminate for three seconds. After this period the pump will operate in accordance with the inputs received.

17 Pump operation

Note: Sections "Keypad functions (Manual, PROFIBUS, Universal and Universal+ only)" below up to and including "Help (Manual, PROFIBUS, Universal and Universal+ only)" on page 111 apply to Manual, PROFIBUS, Universal and Universal+ only. It is only possible to control the Remote pump via the input and output, (I/O) provided.

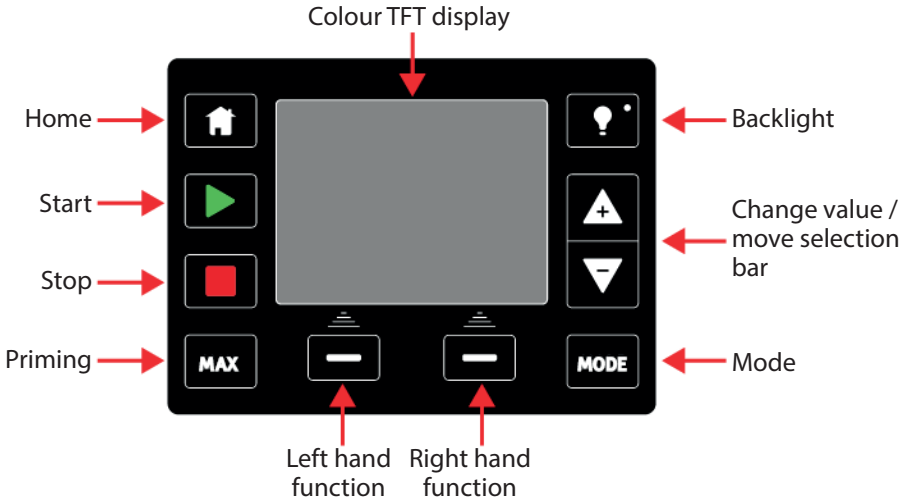
17.1 Pump operation (Remote pump)

The remote pump will operate proportionally to the analog signal provided. The default figures are 4.1mA = 0 rpm, 19.8mA = 125 rpm.

To stop the pump remotely apply a signal, minimum 5V, maximum 24V, to input pin 1. To run the pump in reverse, apply a signal, minimum 5V, maximum 24V to input pin 5.

17.2 Pump operation (Manual, PROFIBUS, Universal and Universal+ only)

Keypad functions (Manual, PROFIBUS, Universal and Universal+ only)



HOME

When the **HOME** key is pressed it will return the user to the last known operating mode. If modifying pump settings when the **HOME** key is pressed, it will disregard any setting changes and return you to the last known operating mode.

START

This key will start the pump at the displayed set speed when in manual mode or flow calibration. This key will deliver a contact dose volume when in **CONTACT** mode. It has no effect in the other remote modes.

STOP

This key will stop the pump when pressed at **any** time.

MAX

This key can be used to prime the pump when in manual mode. When pressed the pump will operate at maximum flow rate.

FUNCTION KEYS

When pressed will perform the function displayed on the screen directly above the relevant function key.

After 30 minutes of no keypad activity, the HMI display will dim to 50% brightness.

To restore full power to the display and reset the timer, press the **BACKLIGHT** key.

+/- KEYS

These keys are used to change programmable values within the pump. For example, flow rate. These keys are also used to move the selection bar up and down in the menus.

MODE




To change modes or mode settings, press the **MODE** key. The **MODE** key can be pressed at any time to enter the mode menu. If modifying pump settings when the **MODE** key is pressed, it will disregard any setting changes and return you to the **MODE** menu.

SCREEN SAVER

The display refreshes every 60 seconds. When this occurs you may notice a brief flash.

Screen Icons (Manual, PROFIBUS, Universal and Universal+ only)

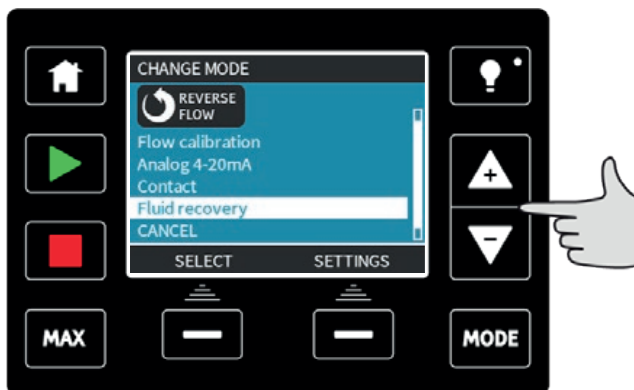
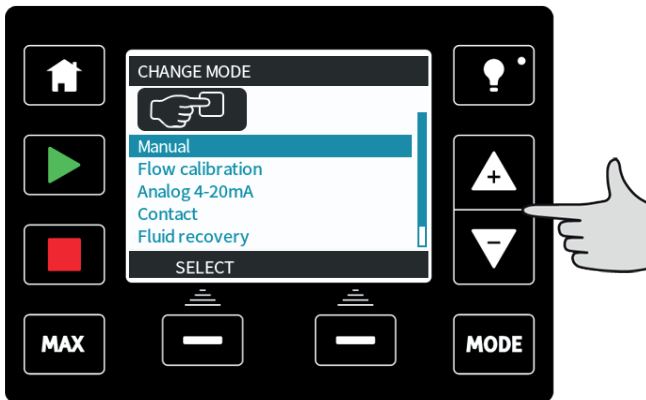
Under certain conditions, various icons will appear in the screen display area:

	The pump displays a RED stop icon when it is in a manually stopped condition. In this state the pump will not start unless the START key is pressed.
	The pump displays a RED PAUSE icon when it is receiving a remote stop input whilst in a standby condition. The pump is placed in a standby condition by pressing the START key in manual mode, or by selecting Analogue mode. In this state the pump will respond to a change in state of the start/stop input, and may start automatically when a control signal is received.
	When the pump is running it displays a turning icon to indicate a pumping state.



Fundamental work with regard to lifting, transportation, installation, starting-up, maintenance and repair should be performed by qualified personnel only. The unit must be isolated from mains power while work is being carried out. The motor must be secured against accidental start-up.

Switching between modes (Manual, PROFIBUS, Universal and Universal+ only)



Note: Remote model does not feature selectable modes.

Using +/- keys will scroll through the available modes. The available modes are:

- **Manual** (default)
- **Flow calibration**
- **Analog 4–20mA** (Universal and Universal+ only)
- **Contact mode** (Universal+ only)
- **PROFIBUS** (PROFIBUS only)
- **Fluid recovery**
- **CANCEL**

Use **SELECT** to choose mode. Use the right hand function key to alter mode settings.

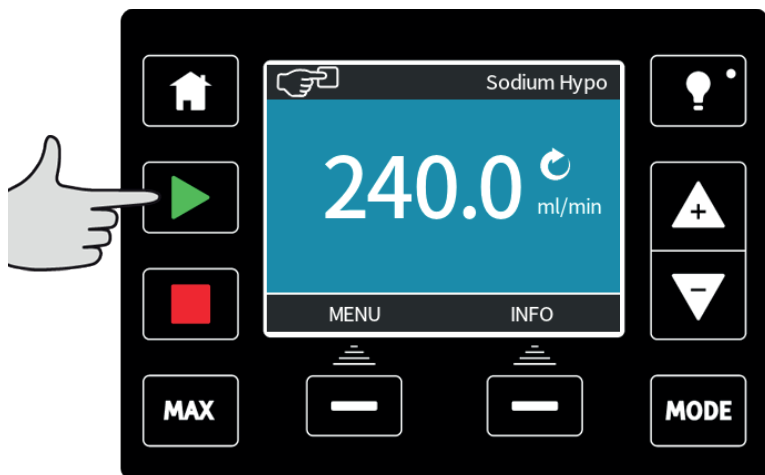
18 Manual mode (Manual, PROFIBUS, Universal and Universal+ only)

All settings and functions of the pump in manual mode are set and controlled by means of key-presses. Immediately after the start-up display sequence (detailed in: "Switching the pump on in subsequent power cycles (Manual, PROFIBUS, Universal and Universal+ only)" on page 50), the manual mode home screen will be displayed unless auto restart is enabled.

If enabled, the pump will return to the last known operating state when the power was lost. When the pump is running it displays an animated clockwise arrow. In normal operation, the direction of flow is into the bottom port of the pumphead and out of the top port.

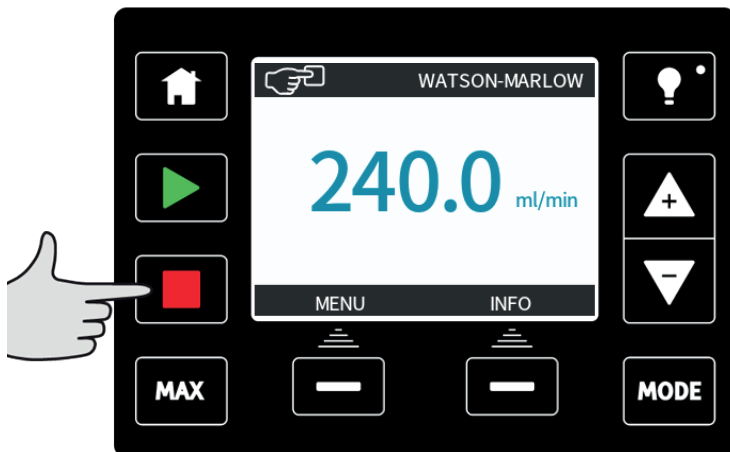
If an exclamation mark (!) is displayed, it indicates that Auto restart is on (see 18.3 General settings on page 57). If a padlock icon shows, it indicates that the keypad lock is on.

START



Starts the pump at the current flow displayed, and the display background changes to blue. If the pump is running pressing this has no effect.

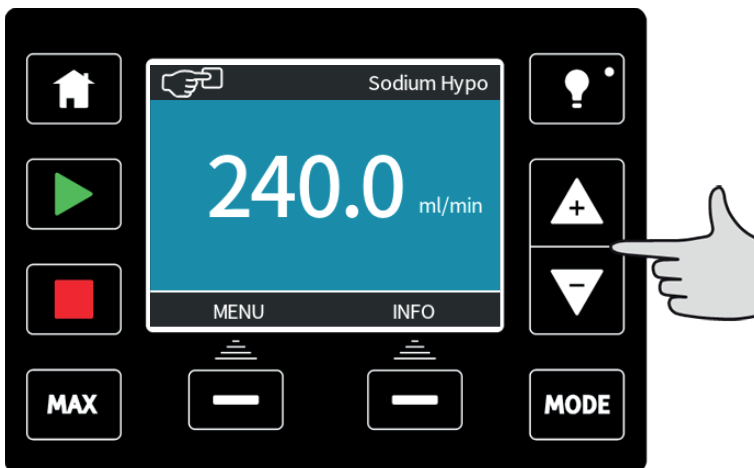
STOP



Stops the pump. The display background changes to white. If the pump is not running pressing this has no effect.

INCREASING AND DECREASING FLOWRATE

Using the +/- keys will increase or decrease the flowrate.



Decreasing flowrate:

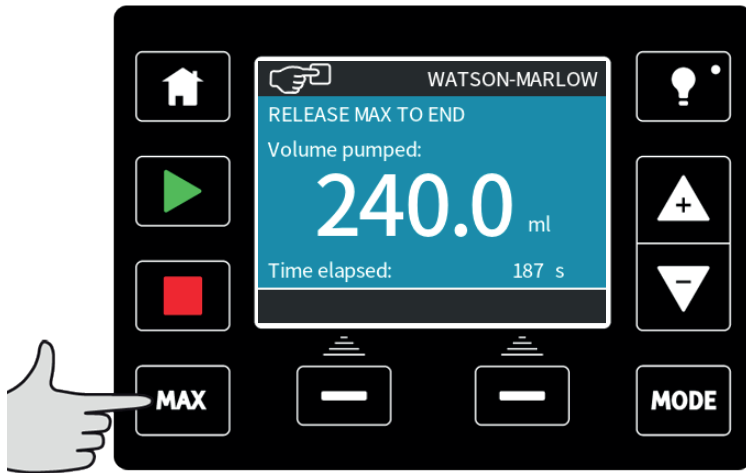
- A single key press will decrease flowrate by the least significant digit of the chosen flowrate unit.
- Repeat key presses as required to achieve the desired flowrate.
- Hold down the key for flowrate scrolling.

Increasing flow rate:

- A single key press will increase flowrate by the least significant digit of the chosen flowrate unit.
- Repeat key-presses as required to achieve the desired flowrate.
- Hold down the key for flowrate scrolling.

Max 100% function (Manual mode only)

- Press and hold the **MAX** key to run at maximum flow.
- Release the key to stop the pump.
- The volume dispensed and time elapsed are displayed whilst the **MAX** key is pressed and held. The **MAX** function will work when the key is pressed in manual mode regardless of the status of the START/STOP input.

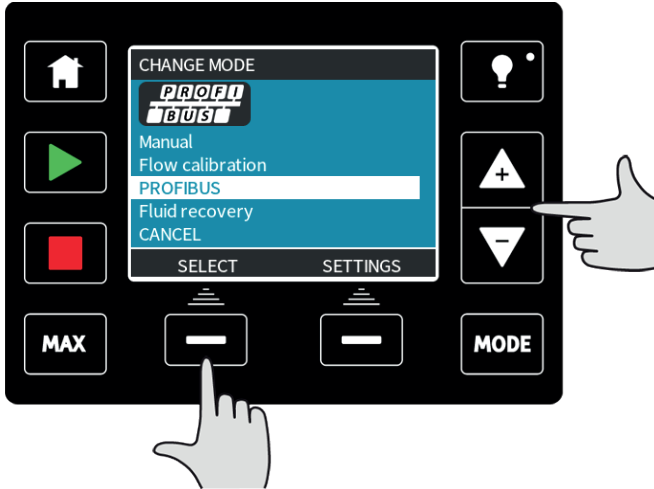


19 PROFIBUS mode(PROFIBUS only)

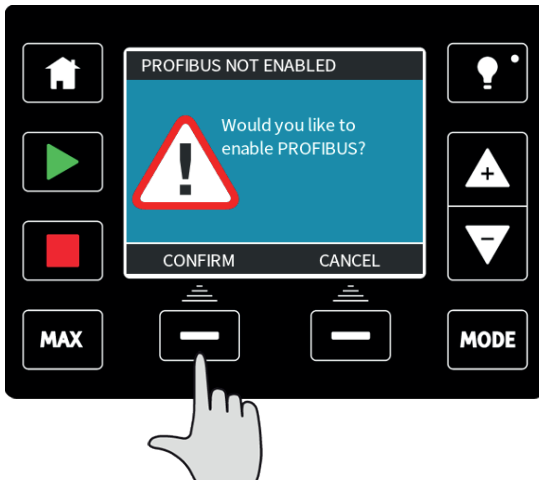
In this operating mode PROFIBUS control can be enabled or disabled. The qdos PROFIBUS pump is designed so that the station address can only be set from the pump. The user can set the station address within this mode.

Select **MODE**

Using the +/- keys scroll to **PROFIBUS** and press **SELECT**



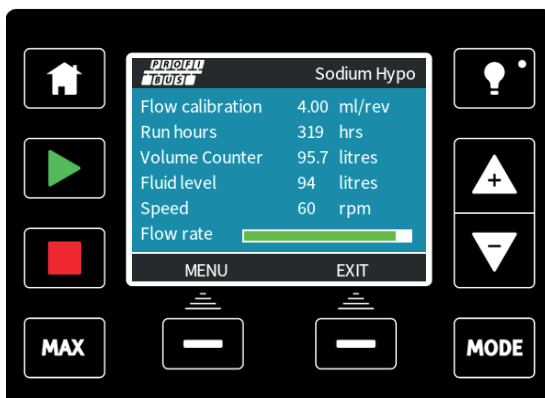
If PROFIBUS is not enabled, the screen below will prompt you to **CONFIRM** that you would like to enable PROFIBUS.



On the PROFIBUS home screen the white **P** icon indicates that there is data exchange.



Pressing the **INFO** function key will display further information.



19.1 Assigning the PROFIBUS station address at the pump

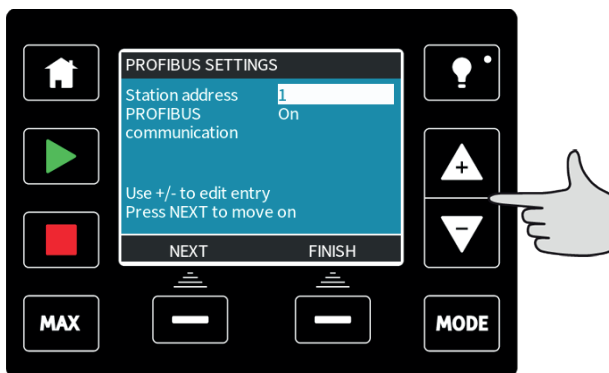
The station address can only be set from PROFIBUS settings. The station address cannot be automatically assigned by the master.

Select **MODE**

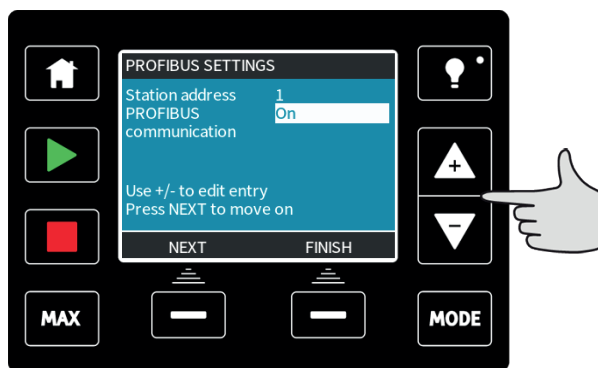
Using the +/- keys scroll to **PROFIBUS** and press **SETTINGS**



Using the +/- keys alter the station address, in the range from 1 to 125. (126 is the default station address).



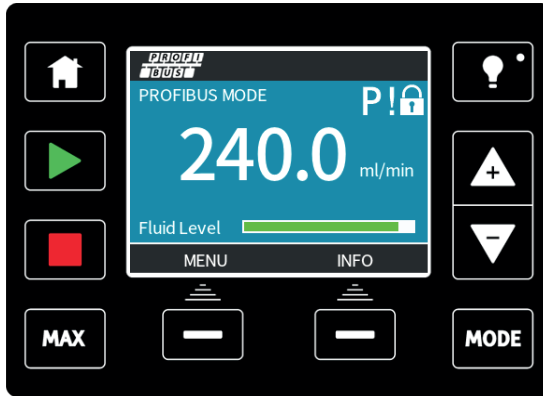
Press **FINISH** to set the station address, or **NEXT** to enable/disable PROFIBUS communication.



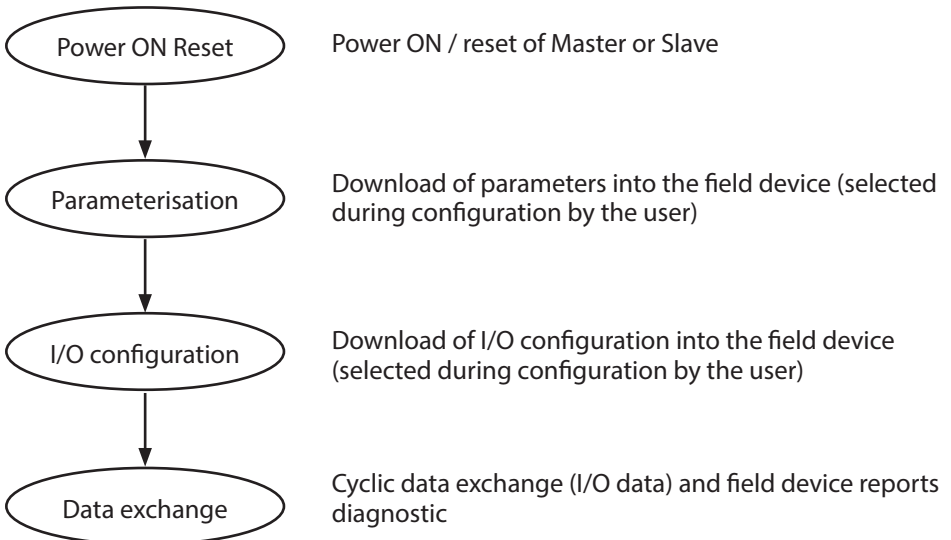
Use the +/- keys to enable or disable PROFIBUS communication and press **FINISH**.

19.2 PROFIBUS communication errors

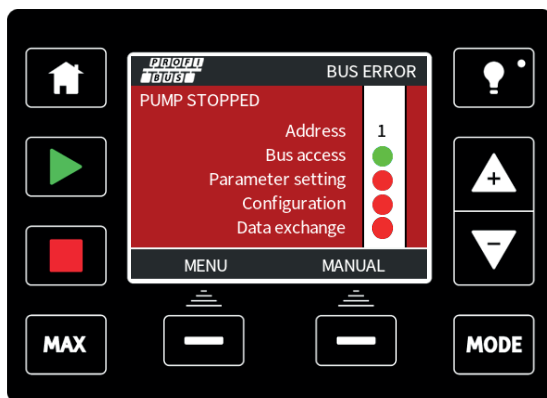
In PROFIBUS mode, the screen below is displayed, the P indicates data exchange is happening.



This screen will only be displayed after successful implementation of Master Slave communications, which always follow the sequence described below.



If data exchange is lost at any time, the following screen will be displayed. The first red dot corresponds to the stage at which the error occurred and subsequent stages will indicate a red dot because the communication sequence halted before this point.



The screen will state running or stopped, depending on how the user has set up the fail-safe function within the PROFIBUS GSD file (see "PROFIBUS GSD file" below). The **MODE** button gives access to the PROFIBUS settings and the station address. When the menus are accessed, the pump is still in PROFIBUS bus mode but with no communications.

After five minutes of inactivity the pump will revert back to the home screen and discard any unsaved changes, if there are still no communications then the BUS ERROR screen will be displayed.

19.3 PROFIBUS GSD file

The qdos PROFIBUS pump can be integrated into a PROFIBUS DP V0 network using a General Station Data (GSD) file. The file identifies the pump and contains key data including its communication settings, the commands it can receive and the diagnostic information it can pass to the PROFIBUS master on interrogation.

The GSD file—file name WAMA0E7D.GSD—can be downloaded from the Watson-Marlow website and installed; or typed into a PROFIBUS master directly from this manual using a GSD editor program.

Note: The data-flow to and from the pump may need to be byte-reversed, due to differences of handling the data between suppliers of master devices.

The GSD file, filename: WAMA0E7D.GSD

```

;
;*****
;*****
;
;*
=====
===== *
;
;*
;*
;* Watson-Marlow Bredel Pumps *
;* Bickland Water Road *
;* Falmouth *
;* Cornwall *
;* TR11 4RU *
;* Tel.: +44(1326)370370 *
;* FAX.: +44(1326)376009 *

```

```

,* *
/
,*
=====
===== *
,* Filename: WAMA0E7D.GSD *
,* GSD file version 3 from 2013-09-24 *
,* ----- *
/* *
/
*****
*****

#Profibus_DP
GSD_Revision = 3
Vendor_Name = "Watson Marlow"
Model_Name = "Qdos Profibus Pump"
Revision = "Version 3.00"
Ident_Number = 0x0E7D
Protocol_Ident = 0
Station_Type = 0
FMS_supp = 0
Hardware_Release = "V1.00"
Software_Release = "V1.00"
Redundancy = 0
Repeater_Ctrl_Sig = 0
24V_Pins = 0
9.6_supp = 1
19.2_supp = 1
45.45_supp = 1
93.75_supp = 1
187.5_supp = 1
500_supp = 1
1.5M_supp = 1
3M_supp = 1
6M_supp = 1
12M_supp = 1
MaxTsd_r_9.6=60
MaxTsd_r_19.2=60
MaxTsd_r_45.45=60
MaxTsd_r_93.75=60
MaxTsd_r_187.5=60
MaxTsd_r_500=100

```

```

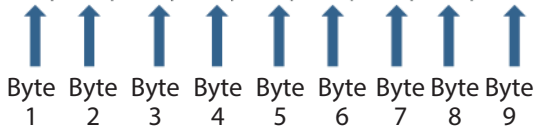
MaxTsdr_1.5M=150
MaxTsdr_3M=250
MaxTsdr_6M=450
MaxTsdr_12M=800
Slave_Family = 0
Implementation_Type = "VPC3+S"
Info_Text="PROFICHIP: PROFIBUS DPV0 - slave, Watson Marlow Qdos"
Bitmap_Device = "WAMA_1N"
Freeze_Mode_supp=1
Sync_Mode_supp=1
Fail_Safe=1
Auto_Baud_supp=1
Set_Slave_Add_supp=0
Min_Slave_Intervall=6
Modular_Station=0
Max_Diag_Data_Len=34
Max_User_Prm_Data_Len = 9
Ext_User_Prm_Data_Const(0)= 0x00,0x00,0x00,0x00,0x00,0x00,0x00,0x00,0x00,0x00
Module="WM Pump, 3/14 word out/in" 0x62,0x5D
1
EndModule

```

19.4 User Parameter Data

The user parameter data is set by entering values into the 'Ext_User_Prm_Data_Const(0)' line of the GSD file. This is indicated below and the relevant bytes are listed in the table. No further changes should be made to the GSD file and Watson-Marlow accepts no responsibility for pump failures arising from changes to the GSD file.

Ext_User_Prm_Data_Const(0)= 0x00,0x00,0x00,0x00,0x00,0x00,0x00,0x00,0x00,0x00



8 bit	Byte 1	Pre Assigned
8 bit	Byte 2	Reserved
8 bit	Byte 3	Min Speed (High byte of 16-bit unsigned)
8 bit	Byte 4	Min Speed (Low byte of 16-bit unsigned)
8 bit	Byte 5	Max Speed (High byte of 16-bit unsigned)
8 bit	Byte 6	Max Speed (Low byte of 16-bit unsigned)

8 bit	Byte 7	Fail Safe
8 bit	Byte 8	Fail Safe Speed (Low byte of 16-bit unsigned)
8 bit	Byte 9	Fail Safe Speed (High byte of 16-bit unsigned)

Set Min/Max Speeds

The Min/Max Speed parameters are used to set the minimum and maximum speed from the PROFIBUS interface. The values are only used if the matching bit in the Control Word is enabled and they are not zero. The values are 16 bit unsigned in 1/10th of RPM of the head speed.

If the user requests the pump to operate at a lower speed than the defined minimum speed from the user parameter data (bytes 3, 4) then the pump will operate at the defined minimum speed.

If a maximum speed has been configured in the user parameter data, then the pump will be limited to this maximum speed even when the master requests a higher rpm.

Fail Safe

The fail-safe user parameter is used to set the correct course of action to take in the event of a PROFIBUS communications failure. The fail-safe byte is configured as shown in the following table. If no bits are set or an invalid bit pattern is set the default fail safe behaviour shall be to stop the pump.

Hex	Description
0x00	The pump will stop
0x01	Continue driving using the last demanded speed
0x02	Continue driving using the fail safe speed
0x03 - 0x07	Reserved

Fail Safe Speed

The fail-safe speed parameter is used to set the speed at which the pump should be driven if a PROFIBUS communications error occurs and if the fail-safe user parameter is set to 0x02.

19.5 PROFIBUS data exchange

The data in this section is provided as reference material for a PROFIBUS network operator. Operating this pump under PROFIBUS control is beyond the scope of this instruction manual. Consult your PROFIBUS network literature for further information.

Default address	126
PROFIBUS Ident	0x0E7D
GSD File:	WAMA0E7D.GSD
Config:	0x62, 0x5D (3 words out, 14 words in)
User parameter bytes:	6

Cyclic Data Write (from Master to pump)

Cyclic Data Write (from Master to pump)		
16 bit	Byte 1 (low), 2 (high)	Control Word
16 bit	Byte 3 (low), 4 (high)	Pumphead Speed Setpoint (unsigned)

Cyclic Data Write (from Master to pump)

16 bit	Byte 5 (low), 6 (high)	Set Flow Calibration in μl per revolution
--------	------------------------	--

Control Word

Bit	Description
0	Motor running (1= Running)
1	Direction (0= CW, 1= CCW)
2	Motor revolution counter reset (1=Reset count)
3	Reserved
4	Enable User Parameter Min/Max Speeds (1= Enabled)
5	Enable Fieldbus master to set Flow Calibration (1= Enabled)
6	Not used
7	Fluid Level Reset
8-15	Reserved

Pumphead Speed Setpoint

The speed setpoint is a 16-bit unsigned integer value that represents the speed of the pump head in 1/10th of RPM. For example 1205 represents 120.5 RPM.

Set Flow Calibration

This parameter is used to set the flow calibration value from the fieldbus interface. The value is a 16 bit unsigned integer representing μl per revolution of the pumphead. Note that this value is only used if bit 5 of the Control Word is enabled.

Cyclic Data Read (from pump to Master)

Cyclic data read (from pump to Master)

16 bit	Byte 1, 2	Status Word
16 bit	Byte 3, 4	Pumphead Measured Speed (unsigned)
16 bit	Byte 5, 6	Hours Run
16 bit	Byte 10,9	No of full motor revolutions
16 bit	Bytes 8,7	Reserved
32 bit	Byte 13, 14, 15, 16	Fluid Level
32 bit	Byte 17, 18, 19, 20	Unassigned
32 bit	Byte 21, 22, 23, 24	Unassigned
32 bit	Byte 25, 26, 27, 28	Unassigned

Status Word

Bit	Description
0	Motor running (1= Running)
1	Global Error Flag (1= Error)
2	Fieldbus Control (1= Enabled)
3	Reserved
4	Over current error
5	Under voltage error
6	Over voltage error
7	Over temperature error
8	Motor stalled
9	Tacho fault
10	Leak detected or pumphead alert for ReNu 20 PU
11	Low Setpoint- Out of range
12	High Setpoint- Out of range
13	Fluid level alert
14	Reserved
15	Reserved

Pumphead Speed

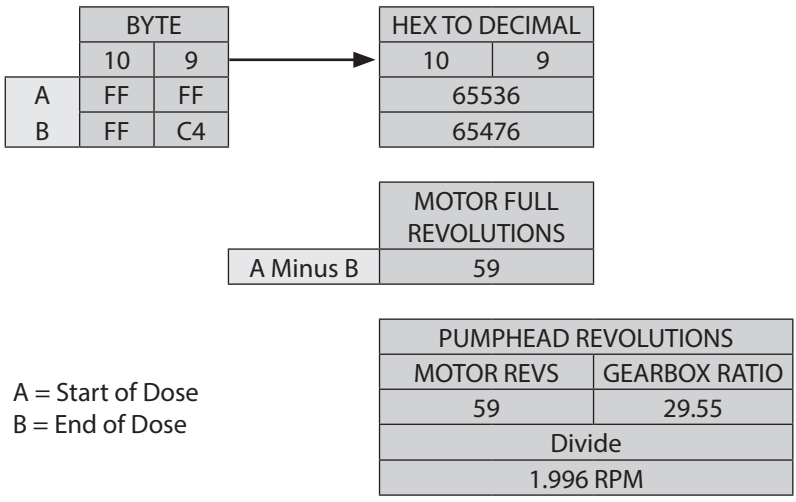
The pumphead speed is a 16-bit unsigned integer value that represents the speed of the pump head in 1/10th of RPM. For example 1205 represents 120.5 RPM.

Hours Run

The hours run parameter is a 16 bit unsigned integer and will represent whole hours of runtime.

No of full motor revolutions

This counts down from FF for each complete motor revolution. Reset this counter to FF by using bit 2 of the control word. The motor relates to the motor inside the pump before the gearbox ratio. The number of pumphead revolutions can be obtained by dividing the number of motor revolutions by the gearbox ratio of 29.55.



Read Flow Calibration

The value is a 16 bit unsigned integer representing µl per revolution.

19.6 Device-related diagnostic data

8 bit	Byte 1	Header Byte
16 bit	Byte 2, 3	Reserved
16 bit	Byte 4, 5	Reserved
16 bit	Byte 6, 7	Min Speed (unsigned)
16 bit	Byte 8, 9	Max Speed (unsigned)
32 bit	Byte 10, 11, 12, 13	Software Version Main CPU
32 bit	Byte 14, 15, 16, 17	Software Version HMI CPU
32 bit	Byte 18, 19, 20, 21	Software Version Flash
32 bit	Byte 22, 23, 24, 25	Software version PROFIBUS CPU

19.7 Channel-related diagnostic data

Channel-related diagnostic blocks are always three bytes long in the following format:

Byte 26	Header
Byte 27	Channel type
Byte 28	Channel-related error code

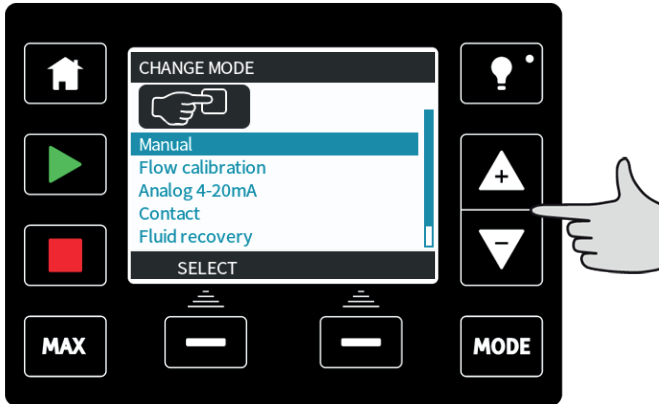
Channel-related diagnostic data	Byte 3
Global error	=0xA9 (General error)
Over current	=0xA1 (Short circuit)
Under voltage	=0xA2 (Under voltage)
Over voltage =0xA3 (Over voltage)	=0xA3 (Over voltage)
Motor stall	=0xA4 (Overload)
Over temp =0xA5 (Over temp)	=0xA5 (Over temp)
Tacho fault	=0xB1 (Device related 0x11)
Leak detected	=0xB2 (Device related 0x12)
Fluid level alert	=0xB3 (Device related 0x15)
Reserved	=0xA6 (Reserved)
Setpoint out of range- high	=0xA7 (Upper limit exceeded)
Setpoint out of range- low	=0xA8 (Lower limit exceeded)

20 Flow calibration mode (Manual, PROFIBUS, Universal and Universal+ only)

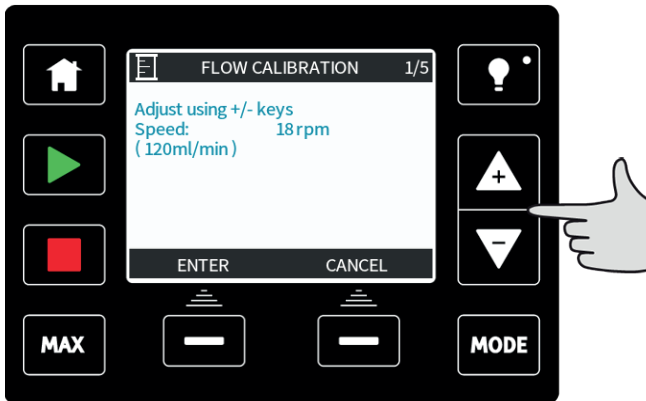
This pump displays flow rate in ml/min.

Setting the flow calibration

Select **MODE**

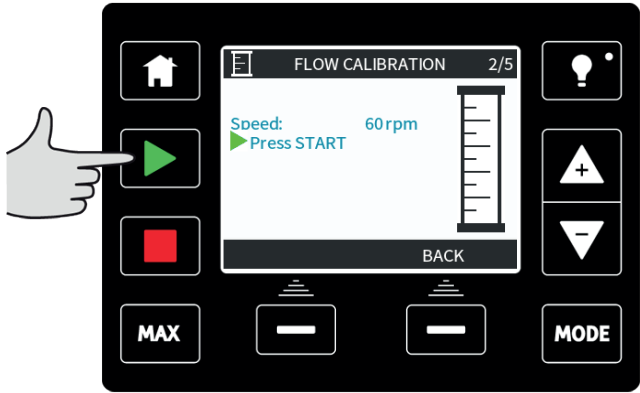


Using the +/- keys, scroll to Flow calibration and press **SELECT**.

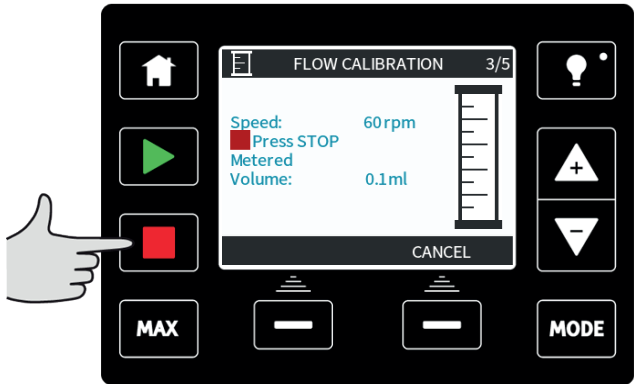


Using the +/- keys enter the maximum flow rate limit and press **ENTER**.

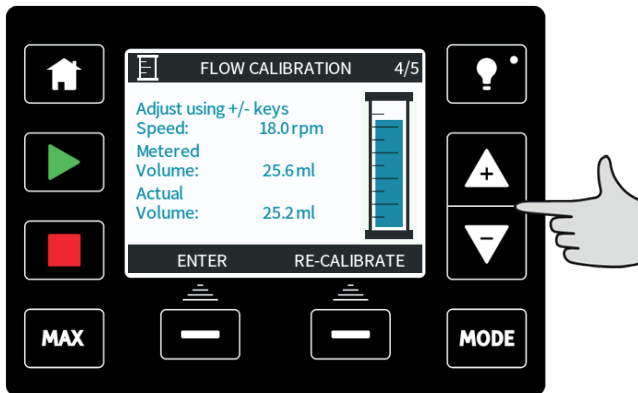
Press **START** to begin pumping a volume of fluid for calibration.



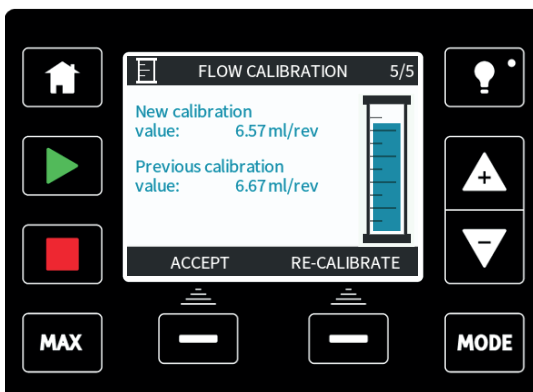
Press **STOP** to stop pumping fluid for the calibration.



Using the +/- keys enter the actual volume of fluid pumped.



To accept the new calibration press **ACCEPT** or **RECALIBRATE** to repeat the procedure. Press **HOME** or **MODE** to abort.



The pump is now calibrated.

21 Analog 4-20mA mode (Universal and Universal+ only)

In this remote operating mode the flowrate will be proportional to the external milliamp signal input received by the pump. The Universal pump will operate at 0rpm when 4.1mA is received and maximum rpm when 19.8mA is received.

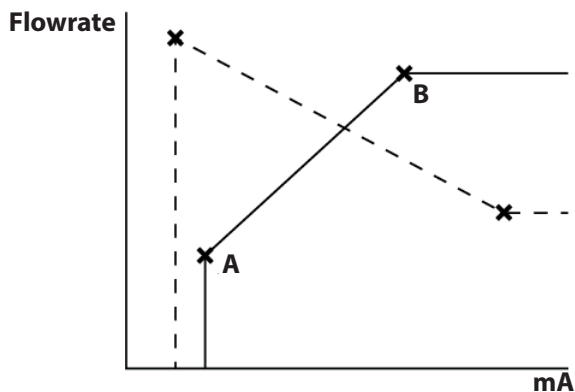
In the Universal+ pump the relationship between the external milliamp signal and the flow rate is determined by configuring the two points **A** and **B** as shown in the graph below. The rate of flow can be proportional or inversely proportional to the analogue milliamp input.

The default values stored in the pump are:

A—4.1mA, 0rpm

B (qdos20)—19.8mA, 55rpm

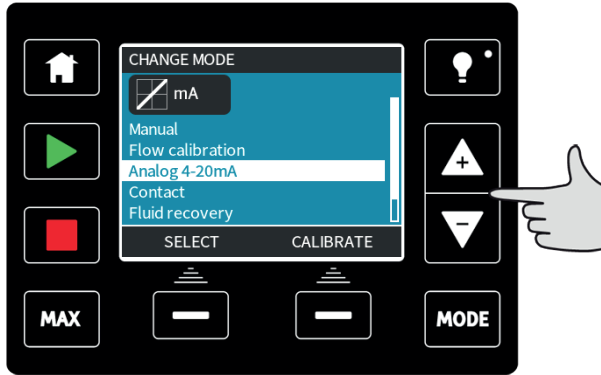
B (qdos30, qdos60, qdos120, qdos CWT)—19.8mA, 125rpm



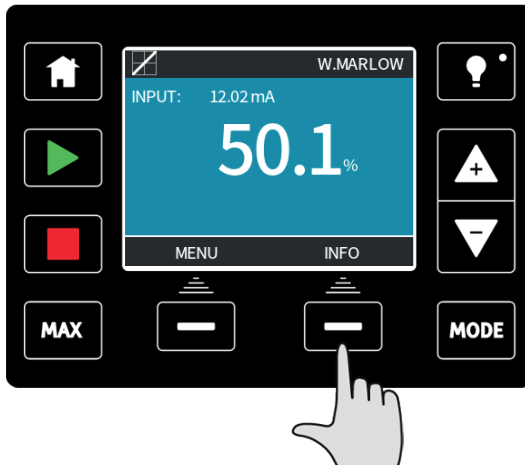
When the mA signal received is greater than the level defined by point A, the run status output will be energised as the pump is running.

To select Analog 4-20mA mode:

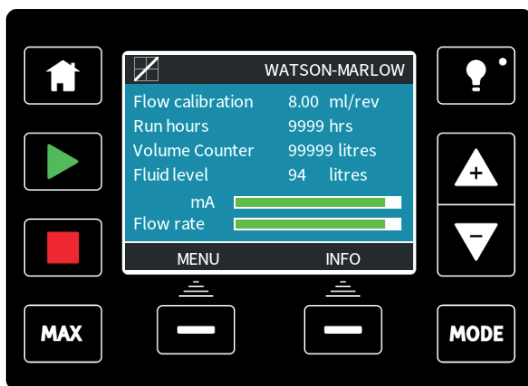
- Select **MODE**.
- Using the +/- keys, scroll to **Analog 4-20mA** and press **SELECT**.



The current signal being received by the pump is displayed, for information only, on the **HOME** screen.



Pressing the **INFO** function key will display further information.

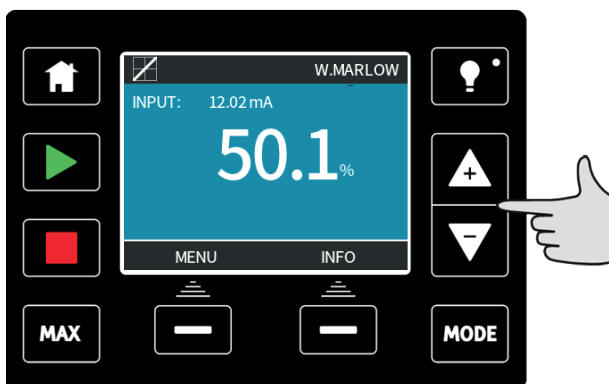


Press the **INFO** key again to display the 4-20mA calibration figures.

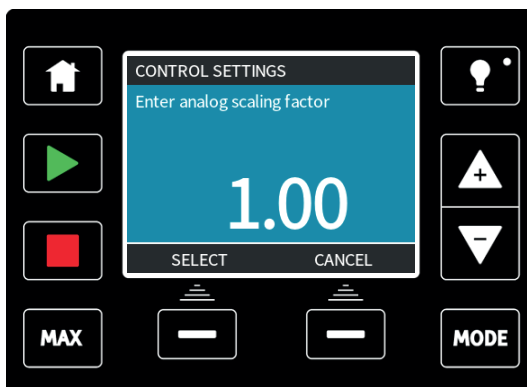
Analog Scaling Factor

The Scaling Factor is a method of adjusting the 4-20mA profile by using a multiplication factor.

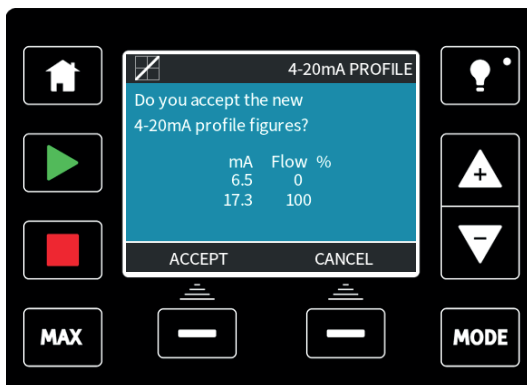
Press **+/-** from the **HOME** screen to access the scaling factor.



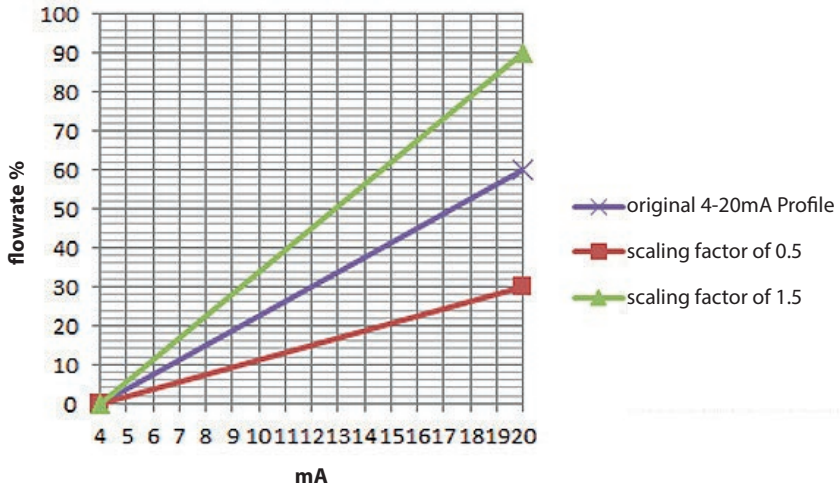
Use the **+/-** keys to enter a multiplication factor. A figure of 1.00 will not alter the 4-20mA profile. A figure of 2 will double the flow rate output from a specific mA signal. A figure of 0.5 will halve the output.



Press **SELECT** once you have chosen the required factor.



Press **ACCEPT** to confirm the new 4-20mA PROFILE figures. This will not alter the stored A and B points, the multiplication factor will re-scale the 4-20mA profile. To re-set the original flow rates re-set the multiplication factor to 1.00.



The 4-20mA profile is a linear relationship where $y=mx+c$ the scaling factor alters the gradient m . The speed limit function in control settings will also scale the analog signal. The difference between scaling factor and speed limit is that the speed limit is a global variable applied in all modes. The speed limit cannot exceed the high flow rate set point (B).

The speed limit function takes precedence over the scaling factor. For example if the qdos20 4-20mA profile is 0% flow at 4mA to 100% flow at 20mA and a speed limit of 33 rpm is applied, followed by a scaling factor of 0.5, then the output will be 30%. If a scaling factor of 2 is applied in the same scenario then the output will be 33 rpm or 60%, as the speed limit takes precedence over the scaling factor.

If you are using manual scaling it is recommended to not use speed limit to avoid confusion.

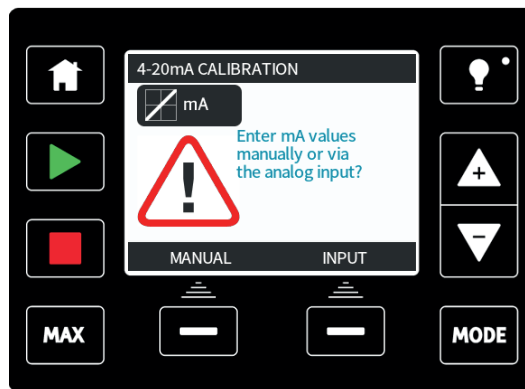
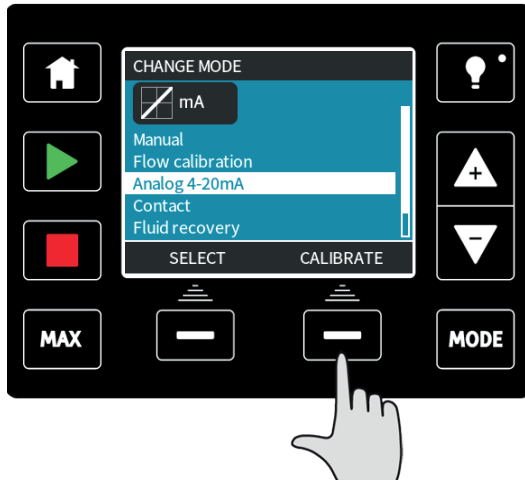
21.1 Calibrate the pump for 4-20mA control (Universal+ only)

This feature is only available in the Universal+ model.

The pump must be stopped before attempting to calibrate the 4-20mA values. High and low signals must be within range. If the signal sent is out of range you will not be able to set the signal input value and progress to the next step in the process.

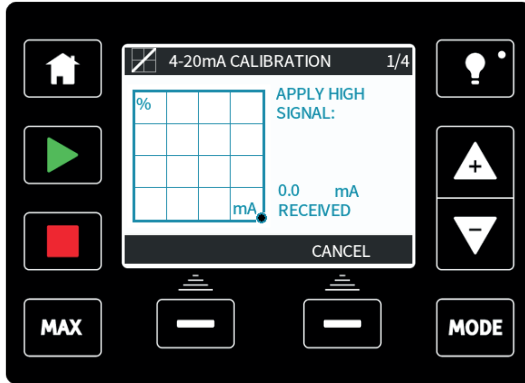
Select **MODE**.

Using the +/- keys scroll to **Analog 4-20mA** and press **CALIBRATE 4-20mA**.

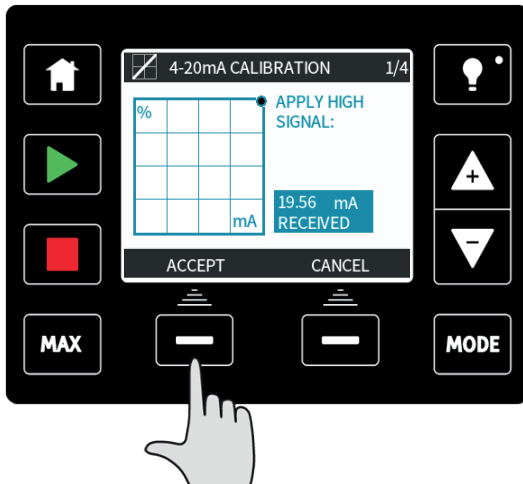


Choose whether to enter the current values manually via the keypad, or whether to apply the current signals electrically to the analog input.

Setting a high signal



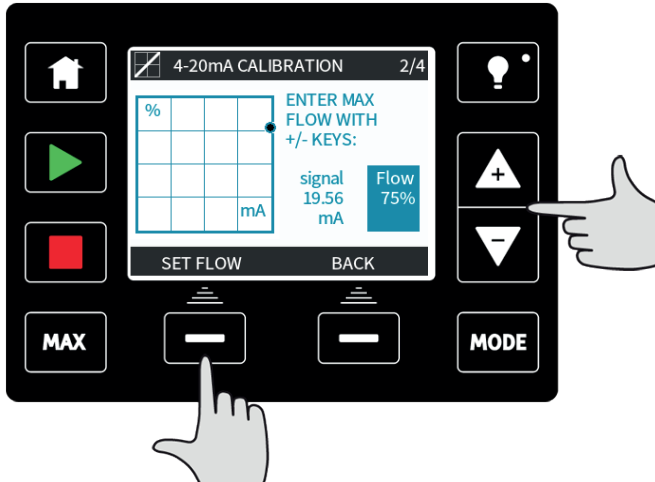
Send the high signal input to the pump, or enter the current value using the +/- keys.



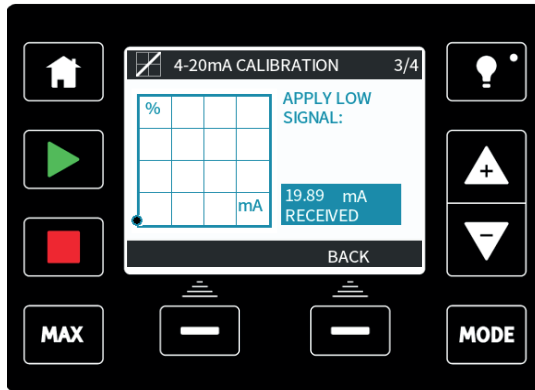
ACCEPT appears when high 4-20mA signal is within tolerance limits. Press **ACCEPT** to accept the high signal input or **CANCEL** to return to the previous screen.

Setting high flow calibration

Using the +/- keys scroll to the desired flow rate. Select **SET FLOW** or press **BACK** to return to the previous screen.

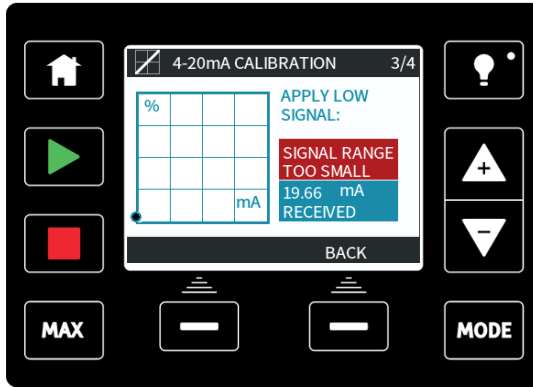


Setting a low signal

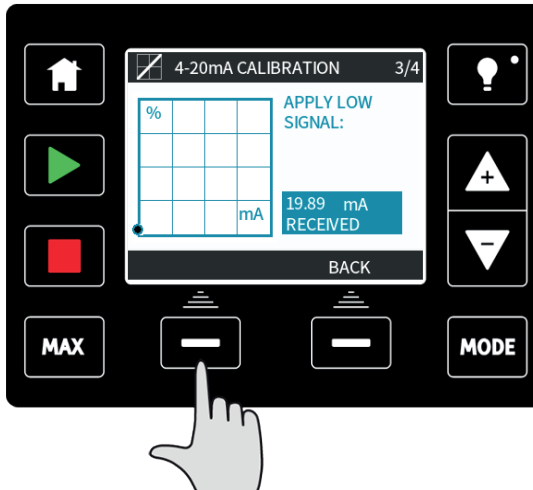


Send the low signal input to the pump, or enter the current value using the +/- keys.

If the range between the low and high signal is less than 1.5mA, the following error message will be displayed.

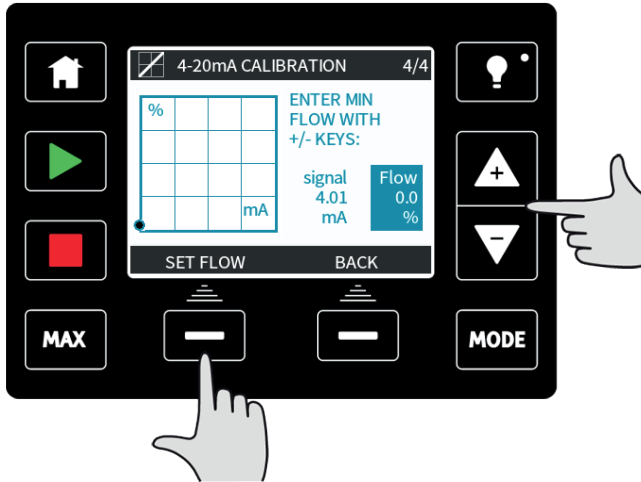


ACCEPT appears when low mA signal is within tolerance limits. Press **ACCEPT** to accept the low signal input or **CANCEL** to return to the previous screen.



Setting low flow calibration

Using the +/- keys scroll to the desired flow rate. Select **SET FLOW**.



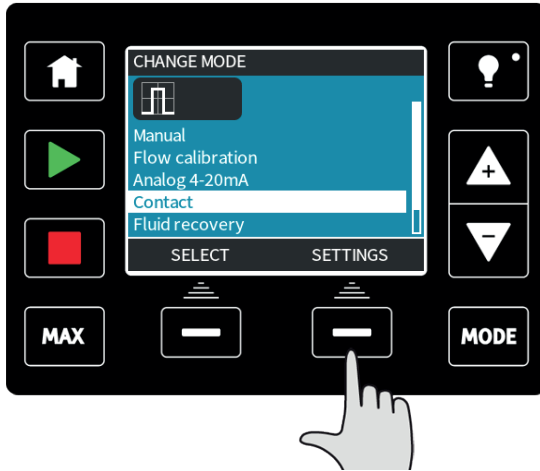
This proceeds to the screen confirming calibration is complete. Select **CONTINUE** to start in proportional mode or **MANUAL** to continue in manual mode.

22 Contact Mode (All Universal and Universal+ models)

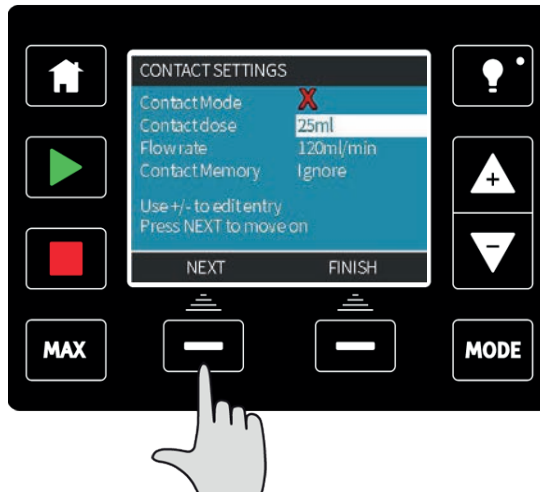
In this operating mode the pump will meter a specific dose of fluid when an external pulse is received.

The dose volume is a user defined value between 0.1ml and 999l.

22.1 Contact settings



To setup contact mode, firstly you will need to define the settings. To do this, press the **MODE** key, move the selection bar to **Contact** and select **SETTINGS** with the right-hand function key.



This will display the settings.

Use **NEXT** to move the selection bar to the next setting.

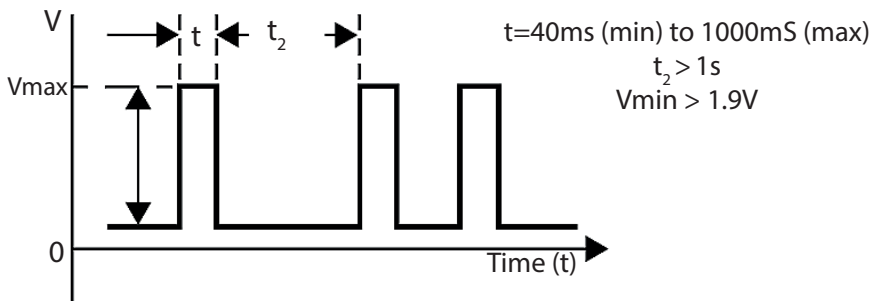
Use +/- to alter the value of the highlighted setting:

- The **contact dose** is the volume of fluid the pump will dispense when an external pulse is received on input pin 2.
- The **flow rate** will determine the time taken to complete each dose.
- **Contact memory** determines what the pump will do when pulses are received while a dose is in progress. If set to "ignore" the pulses will be forgotten by the pump. If set to "add" any pulses received while dosing will be queued up in memory and will be dispensed when the current dose has finished.

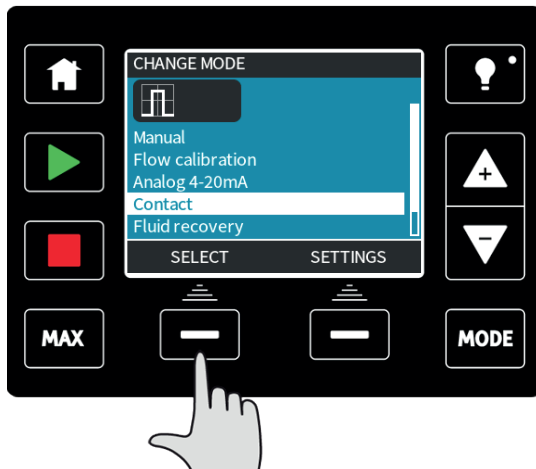
If pulses are buffered in the memory then the pump will not stop between doses.

Once you have decided all your settings press **FINISH** and press **SAVE** to store.

Electrical pulse specification



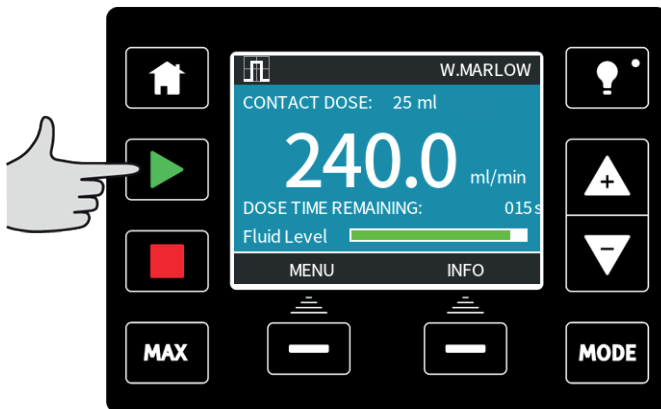
22.2 Contact operating mode (All Universal and Universal+ models)



To enter contact mode press the **MODE** key, move the selection bar to **Contact**, and press **SELECT**.

If **SELECT** is not an available option then choose **SETTINGS** and enable contact mode.

The contact mode home screen will be displayed. The home screen displays the contact dose, the flow rate, and the dose time remaining when a dose is in progress. The dose time is only displayed on screen when it is between 3 seconds and 999 seconds.



When the pump is not dosing it is possible to manually start a dose by pressing the **START** key.

Doses which operate for less than 3 seconds are not recommended.

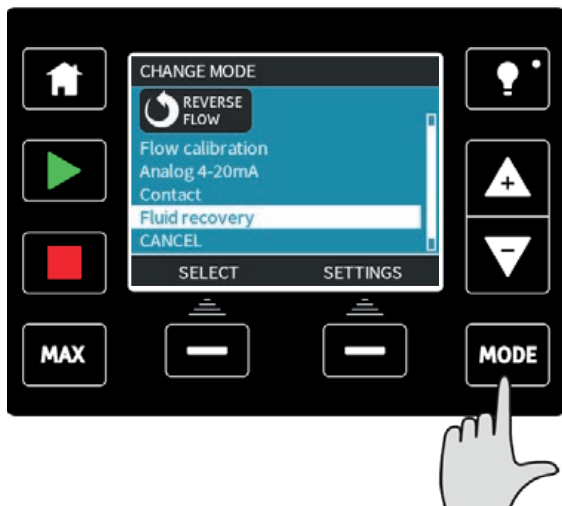
Pulse dosing as an operation mode has its limitations. From an application perspective it is often not the most efficient method of achieving concentration consistency due to the pump only metering when a pulse is received, as opposed to continuously running in proportion to the flow. Intermittently dosing into a fluid line will require enough pipe to ensure the solution is adequately mixed, or a mixing tank.

With the ability to operate at very low speeds, metering chemicals is a much better solution than dosing them at intervals. We recommend examining your process to identify whether a 4-20mA signal can be used rather than a pulse. Where technology does not allow a 4-20mA signal we recommend using a signal converter accessory. This can be used to change your pulse signal to a 4-20mA signal, ideal for metering (see "Analog 4-20mA mode (Universal and Universal+ only)" on page 73).

22.3 Fluid recovery mode (Manual, PROFIBUS, Universal and Universal+ only)

In this operating mode, the pump can be run in reverse for short periods to recover fluid/chemicals pumped. This is mainly used for maintenance purposes.

Press the **MODE** key, using the +/- keys position the selection bar over the fluid recovery menu option and press **SELECT**.



If the pump is already running then the following screen will be displayed. The pump must be stopped before it can be reversed to recover fluid. Press **STOP PUMP**.



An instruction is now displayed. There is a warning to ensure that your system design permits reverse flow. If unidirectional valves are installed then reverse flow will not function and the pump will build up excessive pressure within the pipework.



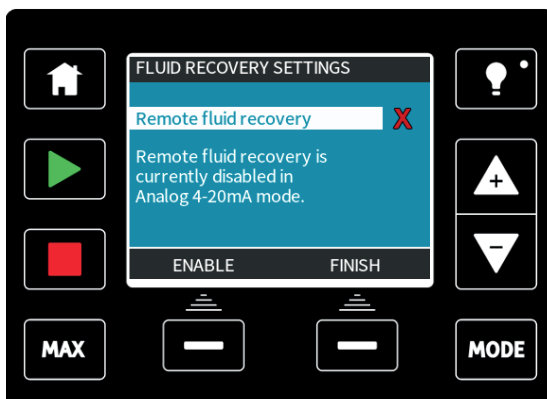
Press and hold **RECOVER** to start running the pump in reverse and recover fluid. The screen below will be displayed whilst **RECOVER** is held down. As fluid is recovered the volume recovered and time elapsed will increase.



Release **RECOVER** to stop running the pump in reverse.

22.4 Remote fluid recovery (Universal and Universal+ models without relay modules)

It is possible to run the pump in reverse and recover fluid automatically in the analog 4-20mA mode. To achieve this, it is necessary to enable remote fluid recovery functionality. To enable this position the selection bar over fluid recovery in the mode menu and press the **SETTINGS** function key.



Select **ENABLE** to turn this functionality on. The reverse process can be used to switch the function off.

When this function is enabled, the pump operation can be reversed in analog 4-20mA mode by applying minimum 5V to maximum 24V to pin 5 of the pump input. The pump will operate at a reversed set speed proportional to the 4-20mA input applied to pin 3.

This operating method allows for fluid recovery from your delivery line. It should not be used for bulk fluid transfer.

Once enabled, remote fluid recovery should be operated in the following sequence:

1. Send a remote stop signal (apply 5 - 24 volts to input pin 1).
2. Apply 5 - 24 volt to pin 5 of the pump input.
3. Remove the remote stop signal.
4. Apply 4 - 20mA to the analog input. This will cause the pump to run in reverse at a speed proportional to the analog signal.
5. Apply remote stop signal when enough fluid has been recovered.
6. Remove the voltage at pin 5 of the pump inputs.
7. Remove the remote stop signal when you are ready to run forwards again.

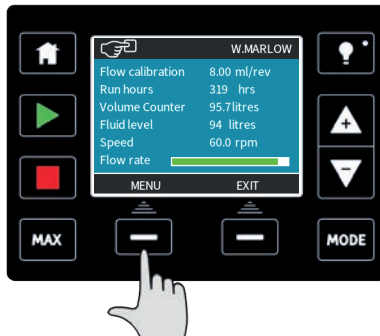
23 Main menu (Manual, PROFIBUS, Universal and Universal+ only)

To access the main menu press the **MENU** button from one of the **HOME** screens or **INFO** screens.

For example: **Manual HOME screen**



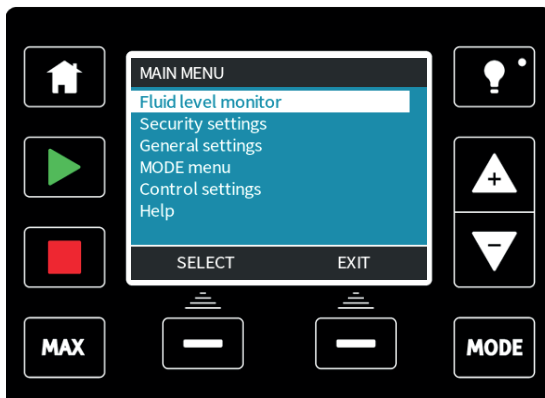
Manual INFO screen



This will display the main menu as shown below. Use the **+/-** keys to move the selection bar between the available options.

Press **SELECT** to choose an option.

Press **EXIT** to return to the screen from where the **MENU** was called.

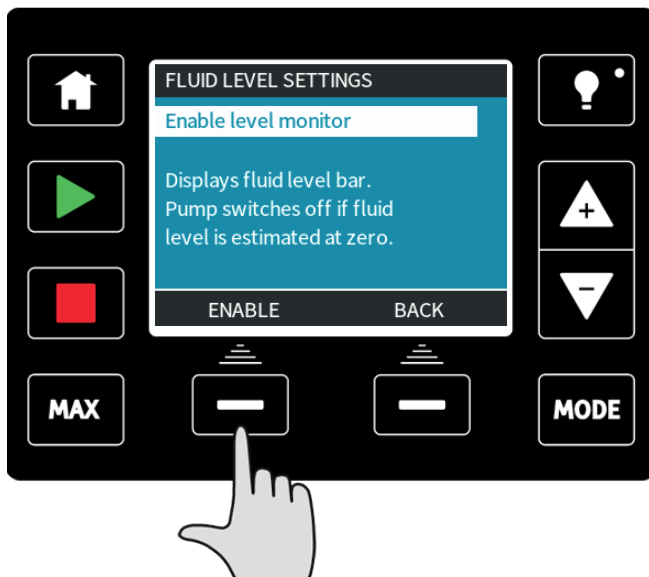


23.1 Fluid level monitor (Manual, PROFIBUS, Universal and Universal+ only)

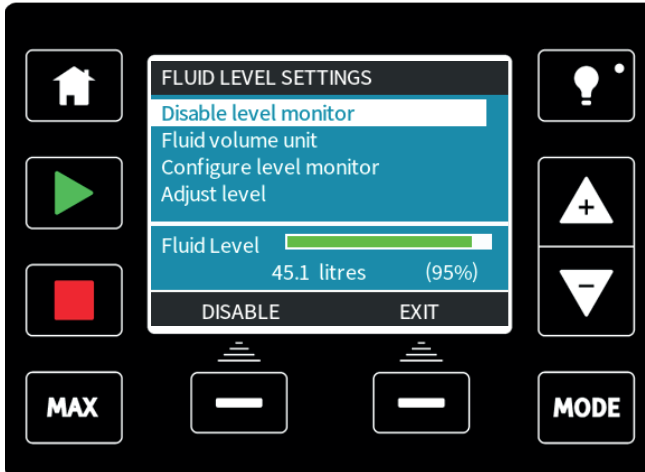
The fluid level monitor can be used to estimate the fluid level left in your supply tank. When activated, the pump will display a bar on the home screen indicating the volume of fluid in the tank. As the pump meters fluid, the volume of fluid in the supply reservoir will reduce, the bar will track the reducing volume. The pump can be set up to output an alarm when a defined level of fluid is reached. This will warn the operator to change the fluid supply barrel or level to ensure that the pump does not run dry.

When the fluid level is estimated at zero the pump will stop.

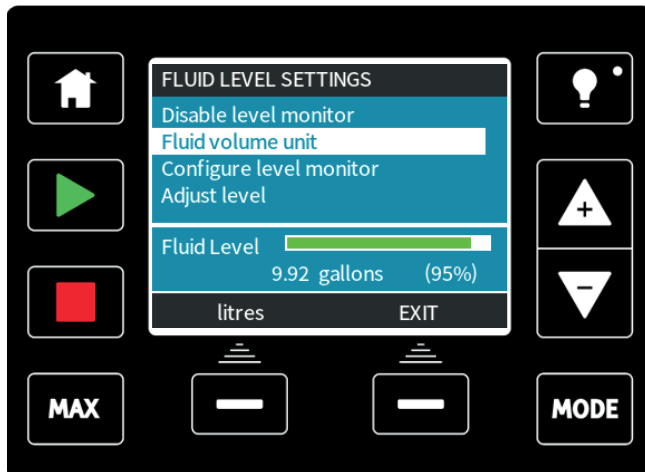
On selection of this function from the main menu, it will ask you whether you wish to **ENABLE** the fluid level bar.



After pressing **ENABLE**, the pump will display the fluid level setup options.

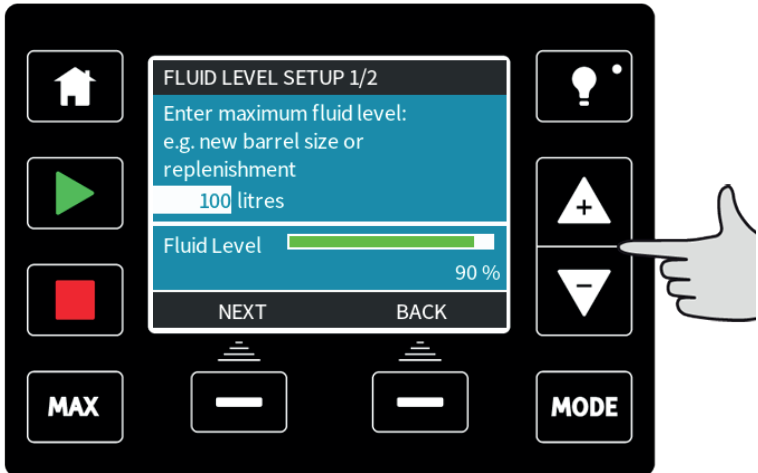


If you press **DISABLE** the pump will deactivate the fluid level monitor. The fluid bar will no longer appear on the **HOME** screens.



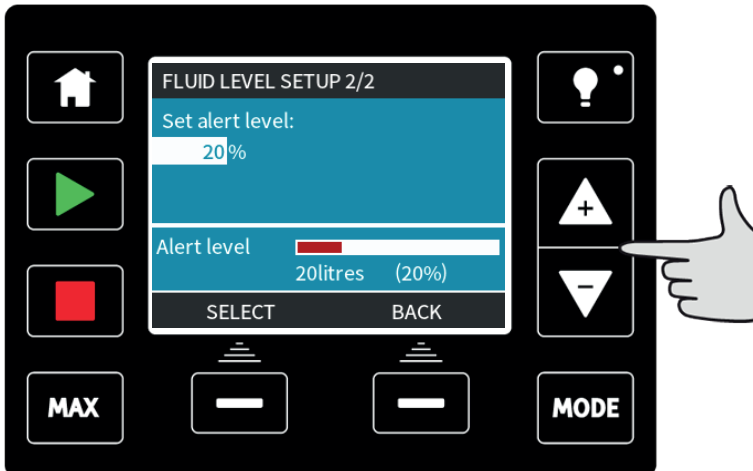
The fluid volume unit can be changed by pressing the **US GALLONS** or **LITRES** key, the key name will change depending upon the unit selected.

To configure the level monitor, select this option from the menu.



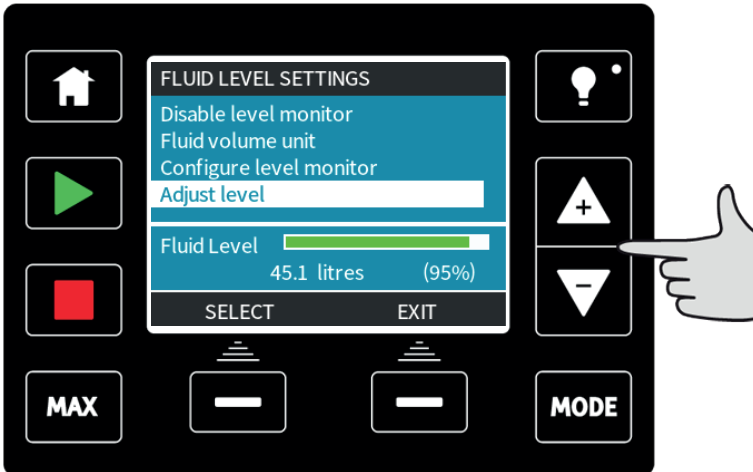
Enter the maximum level of your reservoir or supply container using the +/- keys to adjust the volume.

Press **NEXT** when you are happy you have the correct volume.

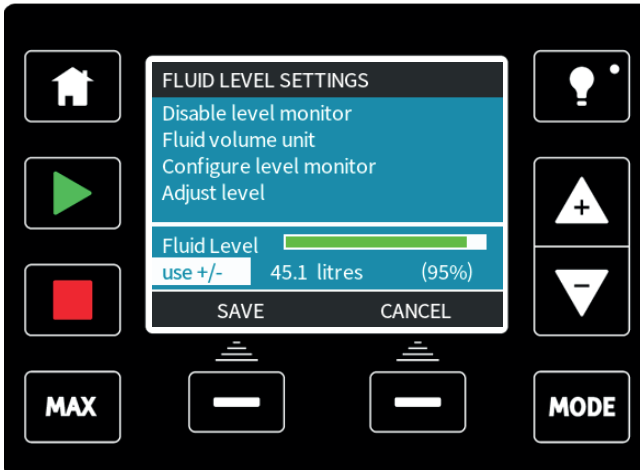


Now use the +/- keys to set the alert level. In the screen above the alert level is set to 20%. Press **SELECT** to return to the fluid level monitor menu.

If you need to adjust the volume of fluid in the tank, for example when re-filling, then press **SELECT** when the bar highlights the **Adjust level** option.



You can now use the +/- keys to adjust the level of fluid in the tank.



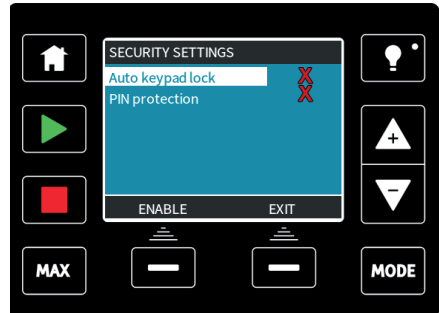
The accuracy of the fluid level monitor will improve with regular calibration of the pump.

23.2 Security settings (Manual, PROFIBUS, Universal and Universal+ only)

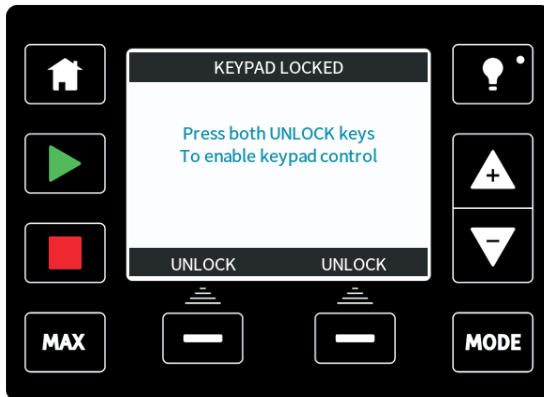
Security settings can be changed by selecting **SECURITY SETTINGS** from the **Main menu**.

Auto keypad lock

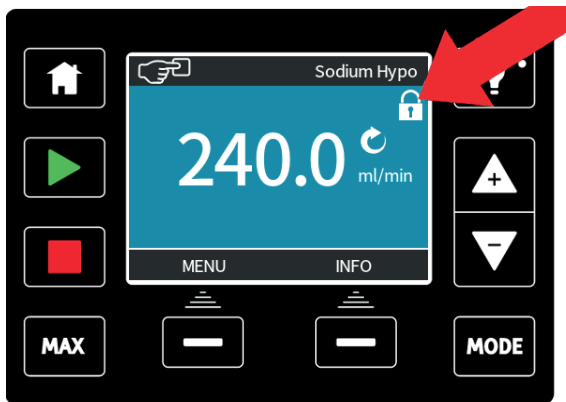
Press **ENABLE/DISABLE** to switch on/off the **Auto keypad lock**. When active the keypad will 'lock' after 20 seconds of inactivity.



Once locked it will display the screen below when any key is pressed. To unlock the keypad press the two unlock keys together.



The padlock icon will appear on the operating mode home screen to show that keypad lock is activated.



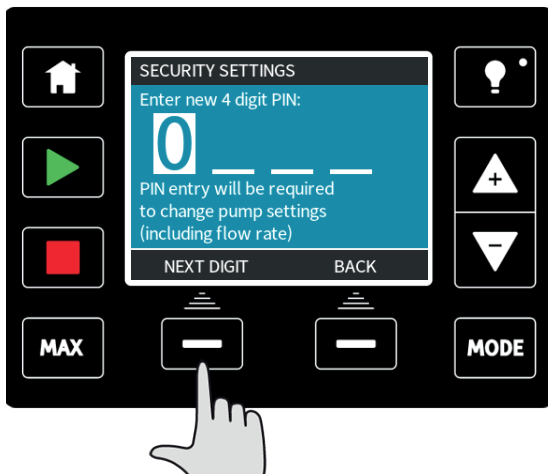
Note that the **STOP** and **BACKLIGHT** keys will always work whether the keypad is locked or not.

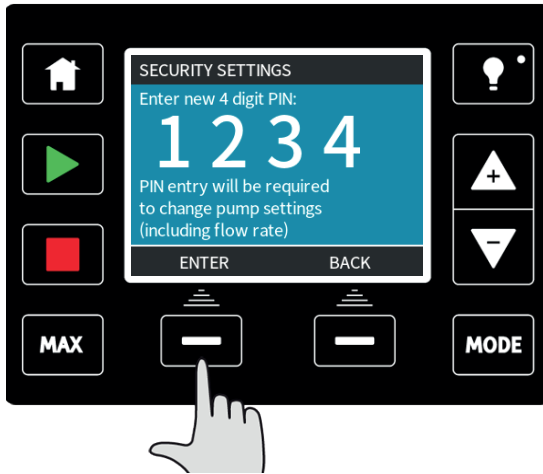
PIN protection

Using the +/- keys in the security settings menu, highlight **PIN protection**.

Press **ACTIVATE/DEACTIVATE** to switch on/off the **PIN protection**. When active, the PIN protection will request a PIN before allowing any change of operating mode settings, or entry to the menu.

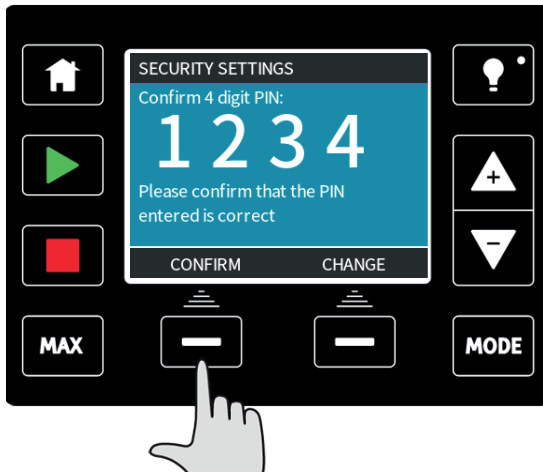
Once a correct PIN has been entered, all settings can be changed. PIN protection will turn back on automatically after 20 seconds of no keypad activity.





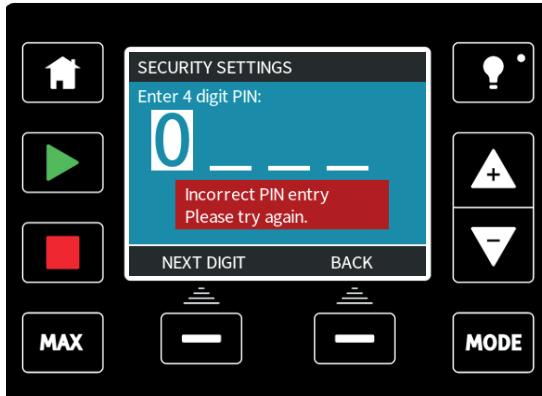
To define a four digit number for your PIN, use +/- to select each digit from 0-9. Once you have the required digit press the **NEXT DIGIT** key. After selecting the fourth digit press **ENTER**.

Now press **CONFIRM** to check that the number entered is the PIN you require. Press **CHANGE** to return to PIN entry.



Pressing the **HOME** or **MODE** key at any time before you confirm your PIN will abort the process.

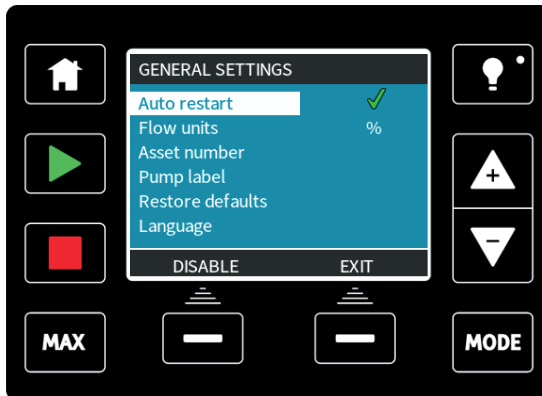
If you enter an incorrect PIN it will display the following screen:



There is an override feature, should you forget your PIN. Please contact Watson-Marlow for details of how to reset the PIN.

23.3 General settings (Manual, PROFIBUS, Universal and Universal+ only)

To view the general settings menu, select **GENERAL SETTINGS** from the main menu.



Auto restart

Press **ENABLE/DISABLE** to turn the auto restart feature on/off.

This pump offers an auto restart feature. If active on power loss, it restores the pump when power returns to the operating state it was in when power was lost. For example, if the pump was running in analog mode prior to power loss, it would return to the same operating mode and continue to run at a proportional speed to the analog input.

This pump offers an auto restart feature. If active on power loss, it restores the pump when power returns to the operating state it was in when power was lost. For example, if the pump was running in manual mode prior to power loss, it would return to the same operating mode and continue to run at the same speed.

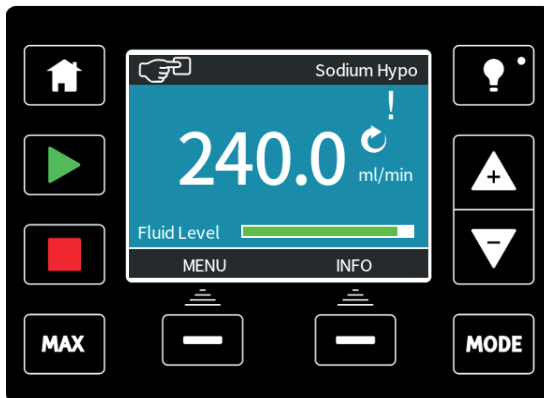
If power is lost in the middle of a dose, when the power is returned it will continue and finish the interrupted dose.

Any pulses that were in memory before power loss will be remembered. Pulses received during power loss will be lost.



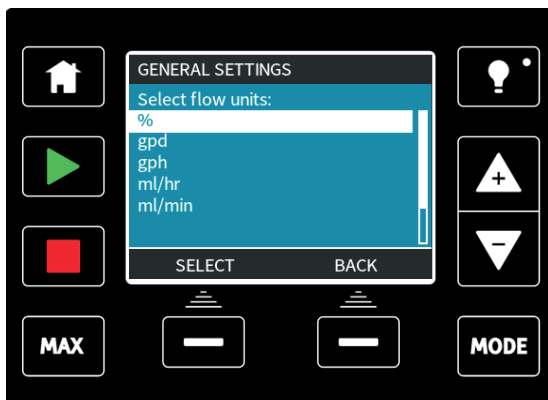
Do not use auto restart for more than 20 mains power starts per hour. We recommend remote control where a high number of starts is required.

The ! icon is displayed on the home screens to indicate that the auto restart feature is active.



Flow units

The current chosen flow unit is displayed on the right hand side of the screen. To change flow units move the selection bar over the flow unit menu entry and press **SELECT**.



Use the +/- keys to move the selection bar over the required flow unit.

Press **SELECT** to define the flow units to use. All flow rates displayed on screens will now be in the chosen units.

Asset number

The asset number is a user defined 10 digit alphanumeric number which can be stored in the pump. This number can be re-called if required from the help screen, accessed from the main menu.

To define or edit the asset number, move the selection bar over the asset number menu entry and press **SELECT**. If an asset number has been previously defined, this will be displayed on screen to allow editing, otherwise the number display will be blank.

Use the +/- keys to scroll through the available characters for each digit. The available characters are 0-9, A-Z, and SPACE.

Press **NEXT** to move onto the next character, or **PREVIOUS** to move back to the previous character.

Press **FINISH** to save the entry and return to the general settings menu.



Pump label

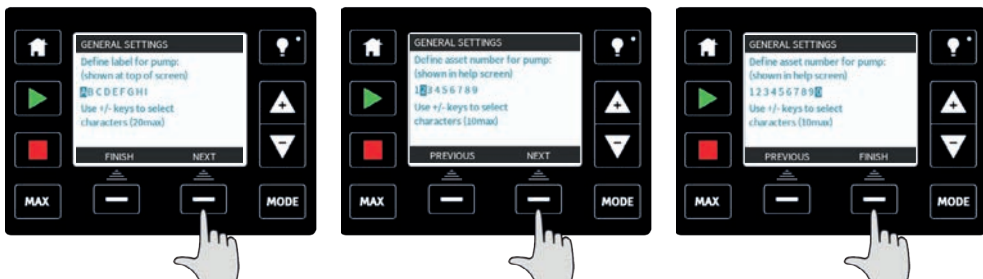
The pump label is a user defined 20 digit alphanumeric label which is displayed in the header bar of the home screen. To define or edit the pump label, move the selection bar over the pump label menu entry and press **SELECT**. If a pump label has been previously defined, this will be displayed on screen to allow editing, otherwise it will display the default label "WATSON-MARLOW".



Use the +/- keys to scroll through the available characters for each digit. The available characters are 0-9, A-Z, and SPACE.

Press **NEXT** to move onto the next character, or **PREVIOUS** to move back to the last character.

Press **FINISH** to save the entry and return to the general settings menu.

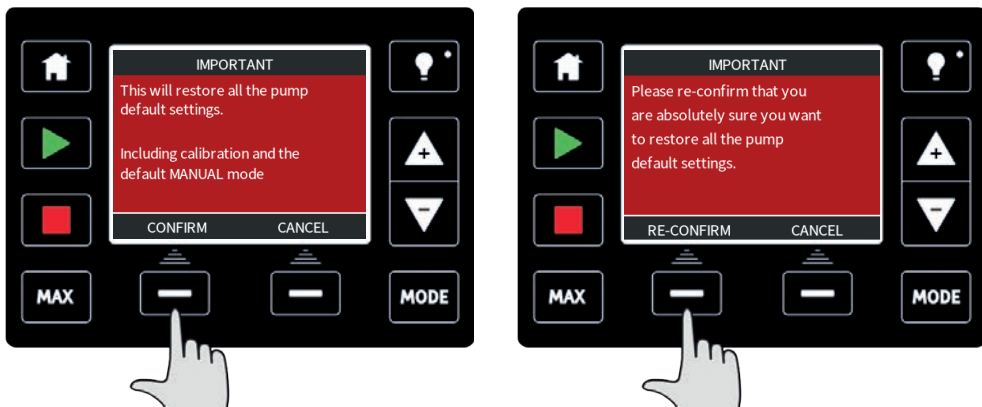


Restore defaults

To restore the factory default settings, select **restore defaults** from the general settings menu.

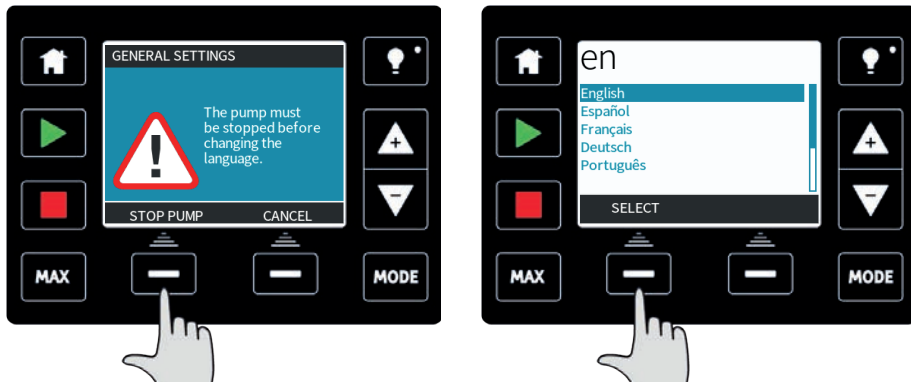
There are two confirmation screens to ensure that this function is not carried out in error.

Press **CONFIRM** followed by **RE-CONFIRM** to reset the defaults.



Language

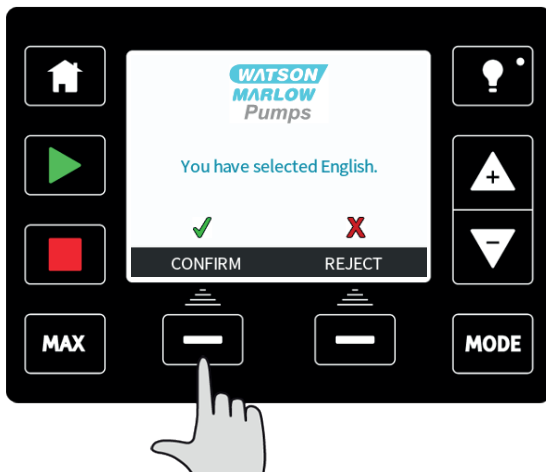
Select **language** from the general settings menu to choose an alternative display language for the pump. The pump must be stopped before changing the language.



Use the +/- keys to move the selection bar to your required language. Press **SELECT** to confirm.

Your selected language will now be displayed on screen.

Press **CONFIRM** to continue, all displayed text will now appear in your chosen language.



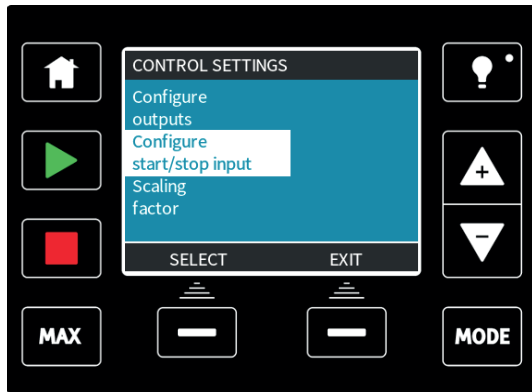
Press **REJECT** to return to the language choice screen.

23.4 MODE menu (Manual, PROFIBUS, Universal and Universal+ only)

Selecting **MODE menu** from the main menu will navigate you to the MODE menu. This is the same as pressing the **MODE** key. Please see "Switching between modes (Manual, PROFIBUS, Universal and Universal+ only)" on page 54 for further details.

23.5 Control settings (Manual, PROFIBUS, Universal and Universal+ only)

Select **CONTROL SETTINGS** from the main menu to access the sub menu shown below.



Use +/- keys to move the selection bar. Press **SELECT** to choose the required function.

Speed limit

The maximum speed the qdos30, qdos60 or qdosCWT pump is capable of running at is 125rpm

The maximum speed the qdos120 pump is capable of running at is 140rpm.

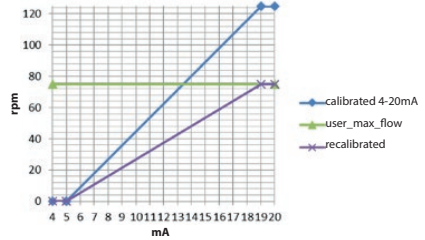
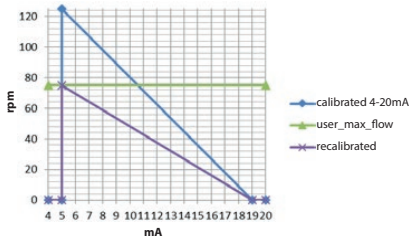
The maximum speed the qdos20 pump is capable of running at is 55rpm.

Select **Speed limit** from the control settings menu to define a lower maximum speed limit for the pump.

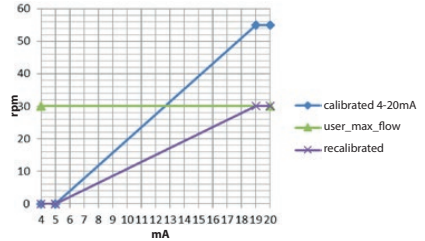
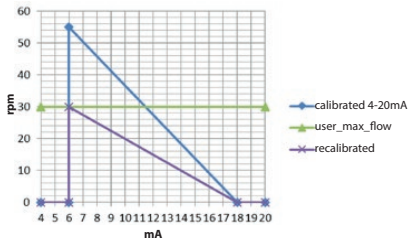
Use the +/- keys to adjust the value and press **SAVE** to set.

Applying a speed limit automatically re-scales the analog speed control response. This speed limit will be applied to all operating modes.

The effect of a 75rpm speed limit on user-defined 4-20mA response profiles



The effect of a 30rpm speed limit on user-defined 4-20mA response profiles



If you purchased your pump prior to 9 February 2017

Check your software version before using this the speed limit setting

Check the software version of the "main processor code" by following the instructions in section 18.6 Help.



If the software version is less than MKS-2.0 then do not use this setting as an intermittent fault condition can result in the pump resetting the speed limit to 125rpm when the power is turned off to the pump.

If you require this functionality on a software version lower than MKS-2.0 please use the 4-20mA calibration method described in Section 15 or contact Watson-Marlow aftersales department to discuss other control methods.

If the version is MKS-2.0 or higher, the speed limit setting may be used.

Reset run hours

Select **reset run hours** from the control settings menu.



Select **RESET** to zero the run hours counter. The run hours counter can be viewed by pressing **INFO** from your home screen.

Reset volume counter

Select **reset volume counter** from the control settings menu.



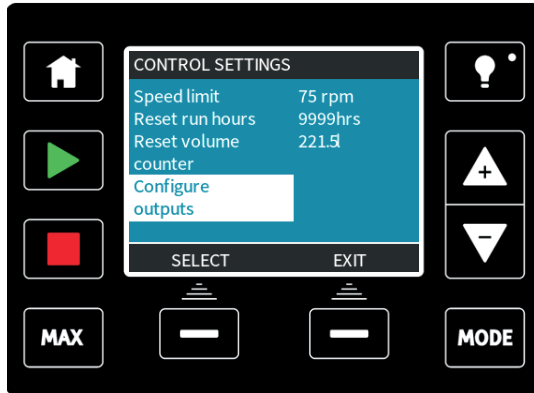
Select **RESET** to zero the volume counter. The volume counter can be viewed by pressing **INFO** from your home screen.

Invert alarm logic - Universal model

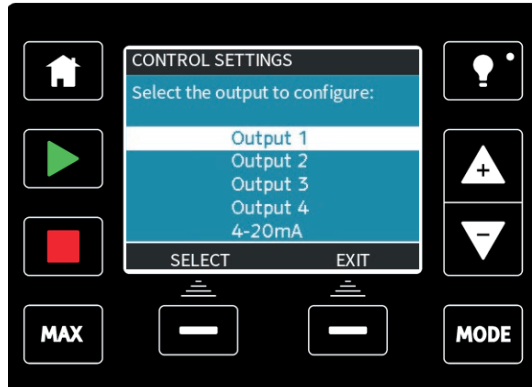
Select **invert alarm logic** from the control settings menu.

Select **ENABLE** to invert the alarm output. The default setting is high for healthy, low for alarm. It is recommended to invert the output for fail safe operation.

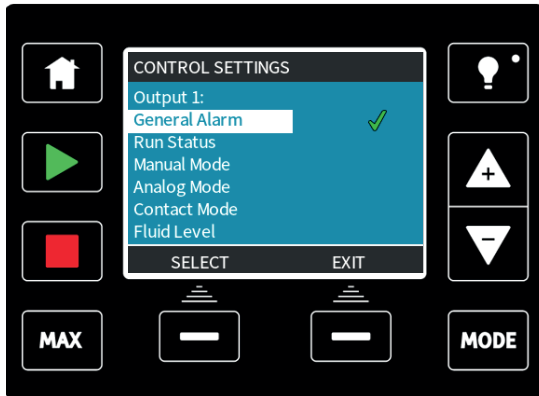
Configurable outputs - Universal+ model



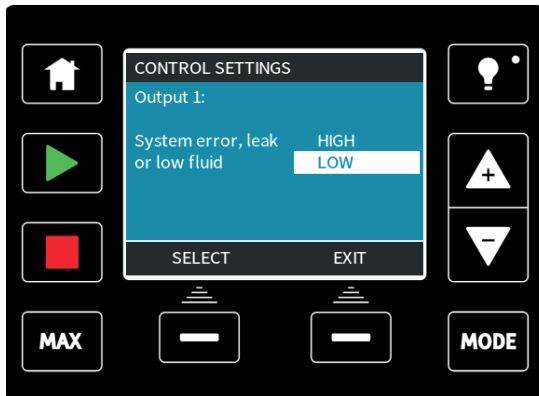
Select **Configure outputs** from the control settings menu.



Use +/- and **SELECT** to choose which output to configure.



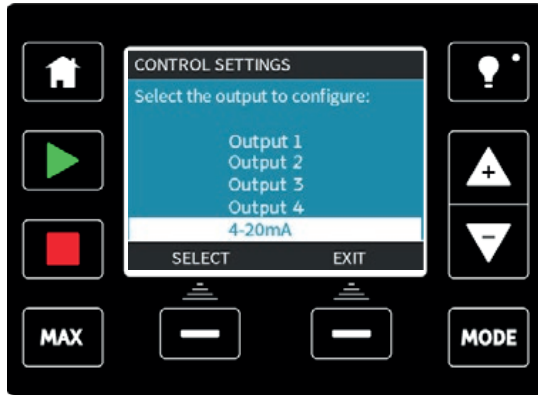
Use +/- and **SELECT** to choose which pump status you require for the chosen output. The tick symbol indicates the current setting.



Use +/- and **SELECT** to choose the logic state of the chosen output.
Press **SELECT** to program the output or **Exit** to cancel.

4-20mA Output (Universal+ model only)

Select **4-20mA** to configure the pumps 4-20mA output response.



Use +/- and **SELECT** to choose the required setting

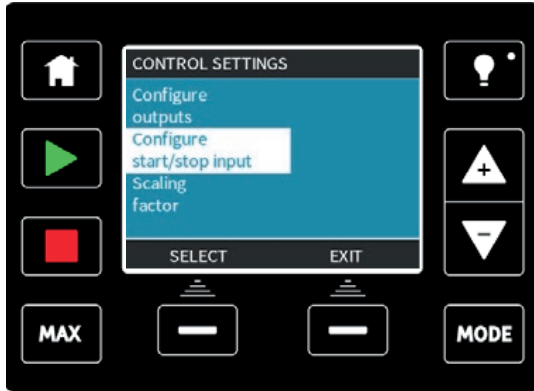


Full scale – The 4-20mA output will be based on the full speed range of the pump. At 0rpm the pump will output 4mA. At maximum rpm the pump will output 20mA.

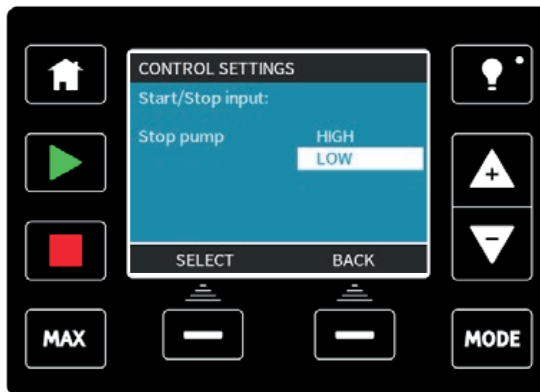
Match input scale – The 4-20mA output will be scaled to the same range as the 4-20mA input. If the 4-20mA input has been scaled to provide 4mA=0rpm and 20mA=20 rpm then an input of 12mA will result in a set speed of 10rpm and an output of 12mA

Configurable Start/Stop input

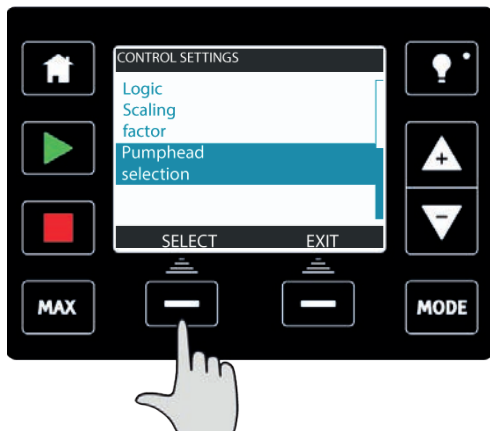
Select **Configure start/stop input** from the menu.



Use +/- and **SELECT** to configure the input setting. A low stop input is recommended as the pump will be stopped in the event of any loss of input signal.



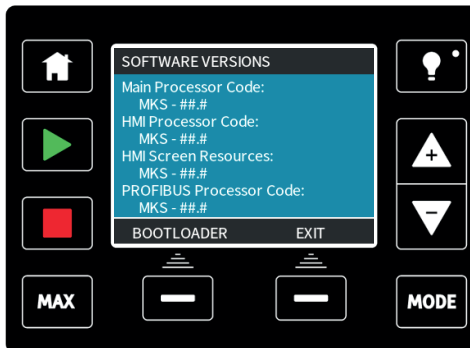
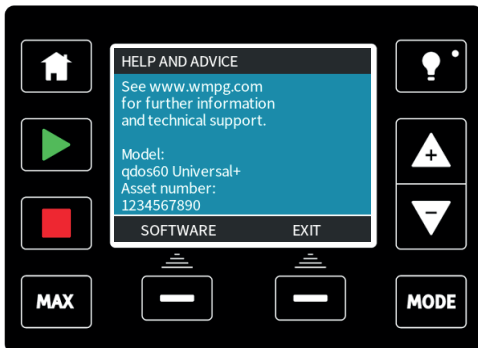
Pumphead selection (qdos20 only)



To change the pumphead selection from one material to another (or to confirm that the pumphead has been replaced early) use +/- and press **SELECT** to make the selection.

23.6 Help (Manual, PROFIBUS, Universal and Universal+ only)

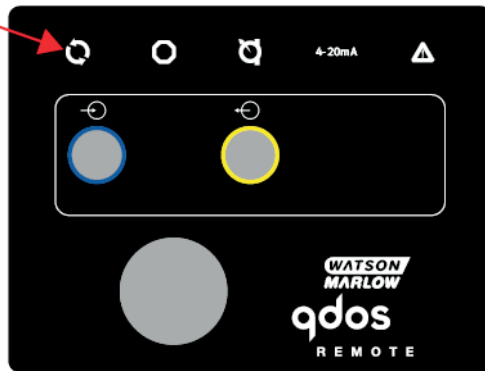
Select **Help** from the main menu to access the help screens.






24 Status LEDs (Remote only)

The remote pump has LED icons on the front panel to indicate its status. A description of the icons and definition of each error state is provided in the table below.

LED Icons



Status	 Running	 Remote stop	 Change pumphead	4-20mA 4-20mA signal
Power on	On			
4-20mA in range	On			On
4-20mA high	On			Flash
4-20mA low	On			Flash
Remote stop		On		Status as above

LED key:

	Signal status
	Pump running
	Pump in standby condition
	Pump stopped

25 Troubleshooting

If the pump display remains blank when the pump is switched on, make the following checks:

- Check that mains power is available to the pump.
- Check the fuse in the wall plug if one is present.

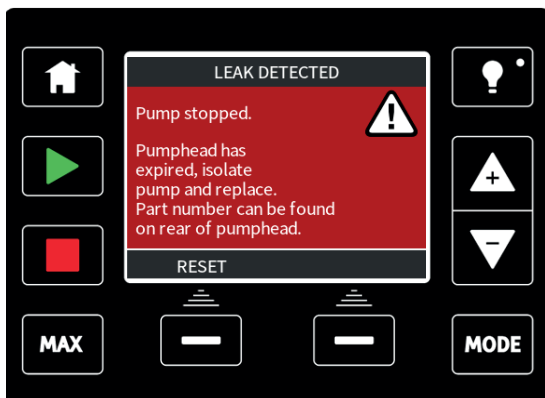
If the pump runs but there is little or no flow, make the following checks:

- Check that fluid is supplied to the pump.
- Check for any kinks or blockages in the lines.
- Check that any valves in the lines are open.

25.1 Leak detection





If a leak is detected the pump will display the following message:

(Manual, PROFIBUS, Universal and Universal+ models)



(Remote only)

If a leak is detected, the following LED icon will display:

Status				4-20mA	
	Running	Remote stop	Change pumphead	4-20mA signal	Error warning
Pumphead requires changing			On		

Follow the instructions in "Pumphead Replacement (qdos 30)" on page 118 "Pumphead Replacement (qdos 20, 60, 120 and CWT)" on page 125 to replace your pumphead.

If this message is repeated when power is cycled, or after the reset button has been pressed, remove the pumphead, check that the mounting face is clean and free of debris and refit the pumphead, taking care to ensure it is correctly orientated with the arrow pointing upwards.

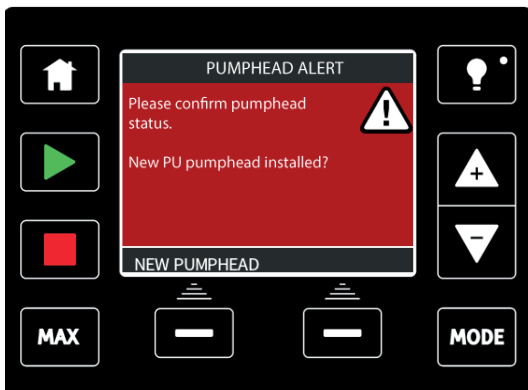
If the message constantly repeats after several pumphead installations, then there may be a leak detection sensor failure.

If the leak detector is faulty, please contact the local WMFTG service centre before using the pump with chemical.

25.2 Pumphead Alert (qdos20, ReNu 20 PU only)

The qdos20 has 'pumphead management software' to stop the pumphead shortly before the end of life of the consumable. This software is in place in order to monitor the pumps life and to prevent tube failures. On start up please select the PU option when asked, or navigate to the control panel in order to select this option.

When the PU pumphead expires a 'PUMPHEAD ALERT' screen will be displayed.



Follow the instructions in "Pumphead Replacement (qdos 20, 60, 120 and CWT)" on page 125.

If the message constantly repeats after several pumphead installations, then there may be a leak detection sensor failure. Please contact Watson-Marlow for repair.

25.3 Error codes

Note: For qdos Remote refer to "Error Indication (Remote only)" on the facing page





If an internal error occurs, an error screen with a red background is displayed. **Note:** **Signal out of range** and **Leak detected** error screens report the nature of an external condition. They do not flash.

Error code	Error condition	Suggested action
Er 0	FRAM write error	Attempt to reset by switching power OFF / ON. Or seek support
Er 1	FRAM corruption	Attempt to reset by switching power OFF / ON. Or seek support
Er 2	FLASH write error during drive update	Attempt to reset by switching power OFF / ON. Or seek support
Er 3	FLASH corruption	Attempt to reset by switching power OFF / ON. Or seek support

Error code	Error condition	Suggested action
Er 4	FRAM shadow error	Attempt to reset by switching power OFF / ON. Or seek support
Er 9	Motor stalled	Stop pump immediately. Check pumphead and tube. Power OFF / ON may reset. Or seek support
Er 10	Tacho fault	Stop pump immediately. Power OFF / ON may reset. Or seek support
Er 14	Speed error	Stop pump immediately. Power OFF / ON may reset. Or seek support
Er 15	Over current	Stop pump immediately. Power OFF / ON may reset. Or seek support
Er 16	Over voltage	Stop pump immediately. Check supply. Power OFF/ON may reset
Er 17	Under voltage	Stop pump immediately. Check supply. Power OFF/ON may reset
Er 20	Signal out of range	Check analog control signal range. Trim signal as required. Or seek support
Er 21	Over signal	Reduce the analog control signal
Er 50	Communication error	Attempt to reset by switching power OFF / ON. Or seek support

25.4 Error Indication (Remote only)

If an internal error occurs, depending on the error one of the following LED icons will be displayed.

Status	 Running	 Remote stop	 Change pumphead	4-20mA 4-20mA signal	 Error warning
Major drive fault: return pump to factory					On
A. Motor stalled/wrong speed: check process/system and switch on/off to reset		On			Flash
B. Voltage error: switch on/off to reset pump					Flash

26 Technical support

support is available from your local Watson-Marlow representative

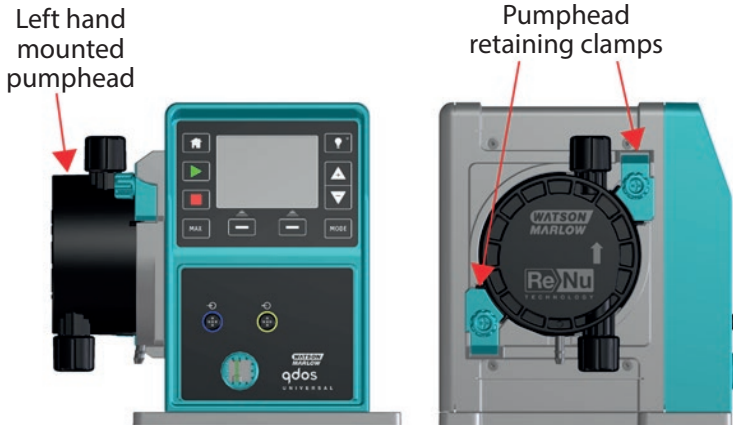
Web: www.wmftg.com

27 Drive maintenance

There are no user serviceable parts inside the pump. The unit should be returned to Watson-Marlow for service. See "Information for returning pumps" on page 10.

28 Pumphead Replacement (qdos 30)

The pumphead is a consumable part and cannot be serviced.



Ensure contaminated pumpheads are not shipped but disposed of locally according to regulations for contaminated items and health and safety procedures.



Always isolate the pump from the mains power supply before changing the pumphead, suction or discharge lines.



It is only possible to fit the pumphead in one orientation with the arrow pointing upwards.



The pumphead retaining clamps should only be unlocked or locked by hand.



Do not continue to run the drive with the leak detect function ignored. The leak detect function is disabled when 'ignore' is selected.



For leak detector to function at all process pressures, the venting screw must be fitted and set to the 'in use' position.

Without venting screw, leak detector will not function with system pressure below 1 bar (15psi).

Note: In this manual, we have shown removal and replacement of the left-hand mounted pumphead. Replacing the right-hand mounted pumphead is the identical procedure.

Removing the pumphead

1. Drain down.
2. Ensure that there is no pressure in the pipeline.
3. Isolate the pump from the mains power supply.
4. Ensure that protective clothing and eye protection are worn if hazardous products have been pumped.
5. Remove input and output connections from the pumphead (protecting the pump from any process fluid spillages).



6. Fully loosen the two pumphead retaining clamps.



7. To disengage the pumphead from the retaining clamps, carefully detach the pumphead from the pump housing and rotate it in an anti-clockwise direction by approximately 15°.



8. Remove the pumphead from the pump housing.



9. Safely dispose of the used pumphead according to your own health and safety regulations. Take care to comply with any safety requirements of the chemical being pumped.

10. Check that the leak detect sensor is clean and free from process chemical



Fitting a new pumphead

Fitting a new pumphead is a reverse procedure of the pumphead removal.

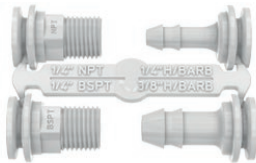
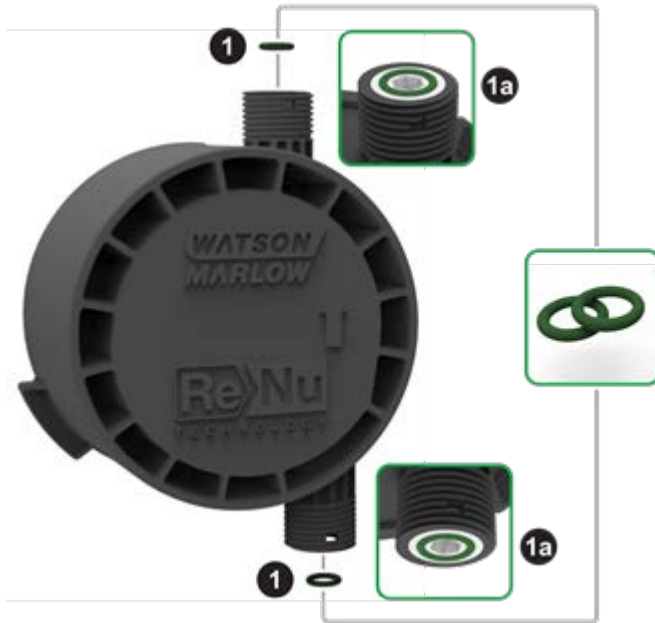
1. Remove the new pumphead from its packaging.
2. Align the new pumphead with the pump drive shaft and slide into position on the pump housing.
3. Rotate the pumphead in a clockwise direction by approximately 15° to engage the retaining clamps.
4. Tighten the retaining simultaneously clamps to secure the pumphead into position.
5. Connect the input and output connections to the pumphead.
6. Apply mains power to the pump, press start and run the pumphead for a few revolutions.
7. Stop the pump and isolate it from the mains power supply, then tighten the clamps further if necessary.

28.1 Connecting interface tubing

Note: Please refer to the diagram below in conjunction to the text when connecting interface tubing to the pumphead.

Before connecting the interface tubing, ensure that the supplied Viton seals **(1)** are correctly fitted in the head ports **(1a)** and that the Santoprene seals and connector material is compatible with pumped fluid.

Note: pumphead appearance will vary between different models



Hydraulic connector pack -
polypropylene barb/threaded fittings

Hydraulic connector pack -
PVDF barb/threaded fittings



Hydraulic connector pack -
polypropylene compression fittings

Note: Hydraulic connector packs are optional accessories. See "Spares and accessories" on page 133.

Hose barbs

1. Detach the desired connector from the sprue **(2)**.
2. Place user connection collar over the chosen fitting and tighten onto the pumphead **(2a)**.
3. Press tube onto connector until it reaches the back face.
4. Secure with suitable retaining clip.

Threaded connectors

1. Detach the desired connector from the sprue **(3)**.
2. Place user connection collar over the chosen fitting and tighten onto the pumphead **(3a)** and **(3b)**.
3. When attaching the mating thread, restrain the connector using a 14mm spanner for the 1/4" BSPT **(3a)**, 9/16" spanner for the 1/4" NPT **(3b)**, 1/2" spanner for the 1/2" BSPT **(3a)** and 13mm spanner for the 1/2" NPT **(3b)**.

Note: It may be necessary to use a thread sealing tape to get a leak-proof seal.

Compression fittings

1. Select the correct compression fittings for the size of tube using the markings on the sprue and detach both the relevant parts **(4)**.
2. Cut the end of the tubing so that it is square **(4a)** and **(4b)** not (4e).
3. Slide the user connection collar onto the tube.
4. Slide the compression ring onto the tube ensuring the inner step is facing the cut end. See **(4a)** and **(4b)** in the diagram on the following page for correct orientation, not (4c) or (4d).
5. Press the tube onto the cone until it reaches the back face **(4a)** and **(4b)** not (4f) (it may be necessary to widen the end of the tube).
6. Whilst continuing to hold the tube against the back face of the cone, slide the compression ring and user connection collar back down the tube and tighten onto the pumphead **(4a)** and **(4b)**.

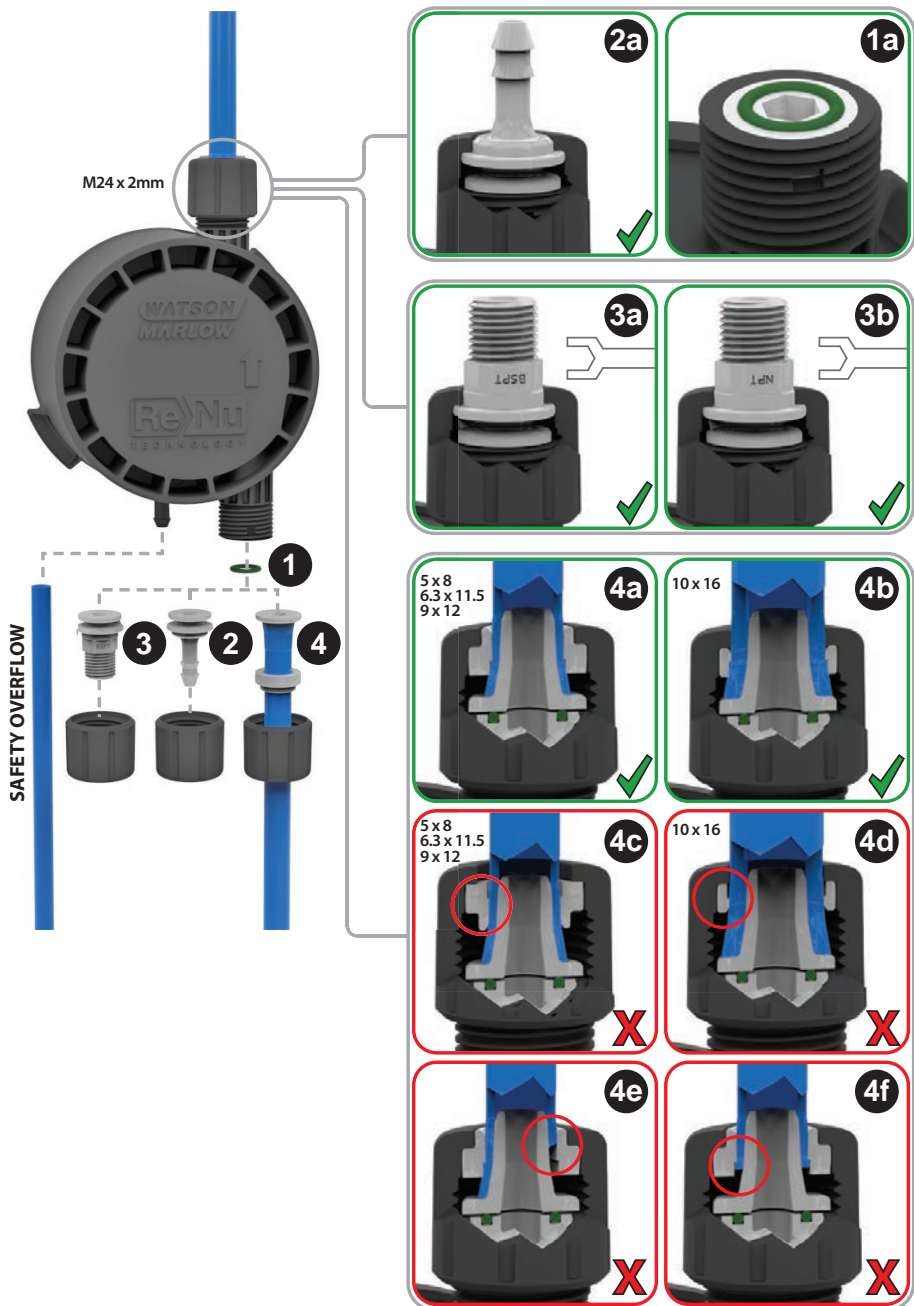
The pump is now ready for use.

Fluid overflow

- When a leak is detected, the leak detection sensor will stop the pump. In the unlikely event of a sensor failure, the safety overflow provides a safe leak path for the mixture of the fluid and lubricant to be removed.
- The user is responsible for ensuring that this overflow is connected to a compatible vented storage container to contain the waste fluid.

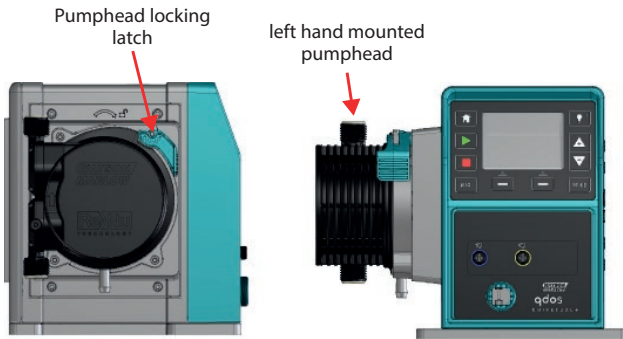


Do not block the drain port of the ReNu pumphead.



29 Pumphead Replacement (qdos 20, 60, 120 and CWT)

The pumphead is a consumable part and cannot be serviced.



The ReNu CWT pumphead will vary in appearance from the ReNu 20, 60 and 120 pumpheads (pictured)



Ensure contaminated pumpheads are not shipped but disposed of locally according to regulations for contaminated items and health and safety procedures.



Always isolate the pump from the mains power supply before changing the pumphead, suction or discharge lines.



Always operate the ReNu pumphead with the pressure valve in the 'in use' position (not applicable for CWT).



It is only possible to fit the pumphead in one orientation with the arrow pointing upwards



The pumphead retaining latch should only be unlocked or locked by hand.



Do not continue to run the drive with the leak detect function ignored. The leak detect function is disabled when 'ignore' is selected

ReNu 20, ReNu 60 or ReNu 120



IMPORTANT: Set the pressure valve to the 'in-use' position before installing the pumphead.

In 'Transportation position' Leak detector will not function with discharge pressure below 1 bar (15 psi).

Note: In this manual, we have shown removal and replacement of the left-hand mounted pumphead. Replacing the right-hand mounted pumphead is the identical procedure.

Removing the pumphead

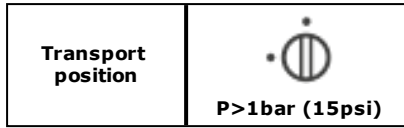
1. Drain down.
2. Ensure that there is no pressure in the pipeline.
3. Isolate the pump from the mains power supply.
4. Ensure that protective clothing and eye protection are worn if hazardous products have been pumped.
5. Remove input and output connections from the pumphead (protecting the pump from any process fluid spillages).



6. Release the pumphead retaining lever.



7. To disengage the pumphead from the drive, rotate it in a clockwise direction by approximately 15°. Move the pressure switch back to 'transport position' (not required for ReNu CWT).



8. Safely dispose of the used pumphead according to your own health and safety regulations. Take care to comply with any safety requirements of the chemical being pumped.



9. Check that the leak detect sensor is clean and free from process chemical

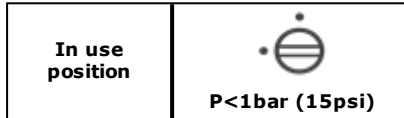


10. If chemical residue is found, isolate the pump from the mains power and contact your local service centre.

Fitting a new pumphead

Fitting a new pumphead is a reverse procedure of the pumphead removal.

1. Remove the new pumphead from its packaging.
2. Turn pressure switch on pumphead to 'in use' position (not required for ReNu CWT).

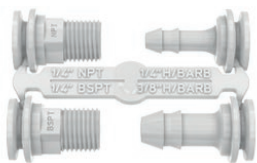


3. Align the new pumphead with the pump drive shaft and slide into position on the pump housing.
4. Rotate the pumphead in an anti-clockwise direction by approximately 15° to engage the retaining lugs.
5. Lock the pumphead into position using the pumphead locking latch.
6. Connect the input and output connections to the pumphead.
7. Apply mains power to the pump, press start and run the pumphead for a few revolutions.
8. Stop the pump and isolate it from the mains power supply, then recheck the retaining lever is still correctly locked in position.
9. **qdos20 PU only:** Confirm NEW PUMPHEAD has been installed

29.1 Connecting interface tubing

Note: Please refer to the diagram below in conjunction to the text when connecting interface tubing to the pumphead.

Before connecting the interface tubing, ensure that the supplied Santoprene seals (**1**) are correctly fitted in the head ports (**1a**) and that the Santoprene seals and connector material is compatible with pumped fluid.



Hydraulic connector pack -
polypropylene barb/threaded fittings



Hydraulic connector pack -
polypropylene compression fittings

Hydraulic connector pack -
PVDF barb/threaded fittings

Note: Hydraulic connector packs are optional accessories. See "Spares and accessories" on page 133.

Hose barbs

1. Detach the desired connector from the sprue **(2)**.
2. Place user connection collar over the chosen fitting and tighten onto the pumphead **(2a)**.
3. Press tube onto connector until it reaches the back face.
4. Secure with suitable retaining clip.

Threaded connectors

1. Detach the desired connector from the sprue **(3)**.
2. Place user connection collar over the chosen fitting and tighten onto the pumphead **(3a)** and **(3b)**.
3. When attaching the mating thread, restrain the connector using a 14mm spanner for the 1/4" BSPT **(3a)**, 9/16" spanner for the 1/4" NPT **(3b)**, 1/2" spanner for the 1/2" BSPT **(3a)** and 13mm spanner for the 1/2" NPT **(3b)**.

Note: It may be necessary to use a thread sealing tape to get a leak-proof seal.

Compression fittings

1. Select the correct compression fittings for the size of tube using the markings on the sprue and detach both the relevant parts **(4)**.
2. Cut the end of the tubing so that it is square **(4a)** and **(4b)** not (4e).
3. Slide the user connection collar onto the tube.
4. Slide the compression ring onto the tube ensuring the inner step is facing the cut end. See **(4a)** and **(4b)** in the diagram on the following page for correct orientation, not (4c) or (4d).
5. Press the tube onto the cone until it reaches the back face **(4a)** and **(4b)** not (4f) (it may be necessary to widen the end of the tube).
6. Whilst continuing to hold the tube against the back face of the cone, slide the compression ring and user connection collar back down the tube and tighten onto the pumphead **(4a)** and **(4b)**.

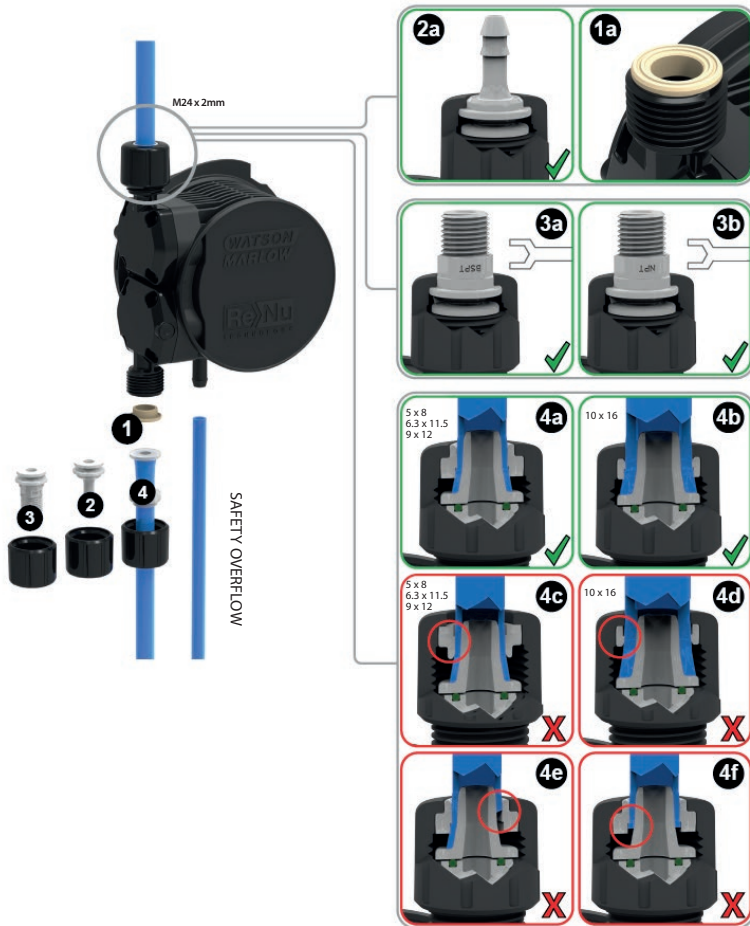
The pump is now ready for use.

Fluid overflow

- When a leak is detected, the leak detection sensor will stop the pump. In the unlikely event of a sensor failure, the safety overflow provides a safe leak path for the mixture of the fluid and lubricant to be removed.
- The user is responsible for ensuring that this overflow is connected to a compatible vented storage container to contain the waste fluid.



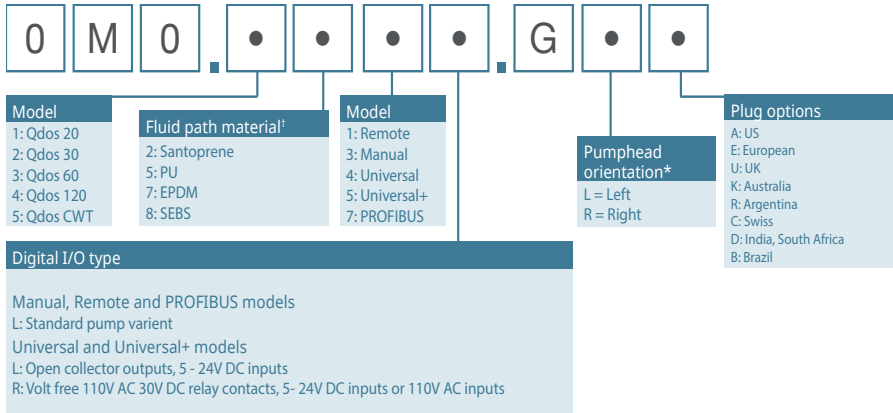
Do not block the drain port of the ReNu pumphead.



The ReNu CWT pumphead will vary in appearance from the ReNu 20, 60 and 120 pumpheads (pictured)

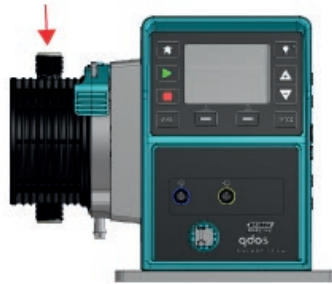
30 Ordering information

30.1 Pump part numbers



* The pumphead side location is required when ordering. The left/right perspective assumes the user is looking at the front of the pump. The pump in the dimensions diagram is considered a pumphead located to the left.

Left hand mounted pumphead



** Important note: The ReNu pumphead contains lubricant. It is the user's responsibility to comply with local health and safety regulations, including ensuring chemical compatibility between the lubricant and the duty fluid before use. The standard lubricant is PFPE.

† To choose the best material for your duty fluid please use the chemical compatibility chart at www.qdospumps.com

30.2 Spares and accessories

Image	Description	Part number	
	ReNu Santoprene pumphead (PFPE lubricant)	qdos30	0M3.2200.PFP
		qdos60	0M3.3200.PFP
		qdos120	0M3.4200.PFP
	ReNu SEBS pumphead (PFPE lubricant)	qdos20	0M3.1800.PFP
		qdos30	0M3.2800.PFP
		qdos60	0M3.3800.PFP
	ReNu PU pumphead (PFPE Lubricant)	qdos20 PU	0M3.1500.PFP
	ReNu CWT pumphead (PFPE lubricant)	qdos CWT	0M3.5700.PFP
	Hydraulic connection pack, polypropylene compression fittings—Set of four sizes : 6.3x11.5mm, 10x16mm, 9x12mm, 5x8mm for use with WM Interface tubing.		0M9.221H.P01
	Hydraulic connection pack, polypropylene barb/threaded fittings, 1/4" hose barb, 3/8" hose barb, 1/4" BSP, 1/4" NPT		0M9.221H.P02


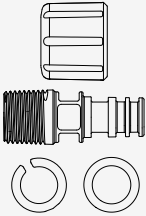


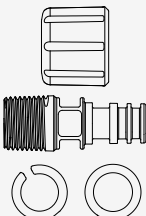

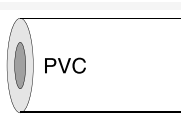
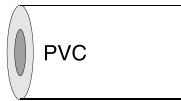
Image	Description	Part number
	<p>Hydraulic connection pack, PVDF barb/threaded fittings, 1/4" hose barb, 3/8" hose barb, 1/4" BSP, 1/4" NPT</p>	<p>0M9.221H.F02</p>
	<p>Hydraulic connection pack, polypropylene, threaded fittings, 1/2" BSP (Only for ReNu 20, ReNu 60, ReNu 120 and ReNu CWT pumpheads. Not available for ReNu 30 pumpheads)</p>	<p>0M9.401H.P03</p>
	<p>Hydraulic connection pack, polypropylene, threaded fittings, 1/2" NPT (Only for ReNu 20, ReNu 60, ReNu 120 and ReNu CWT pumpheads. Not available for ReNu 30 pumpheads)</p>	<p>0M9.401H.P04</p>
	<p>Hydraulic connection pack, polypropylene, 1/2" hose barb</p>	<p>0M9.401H.P05</p>
	<p>Hydraulic connection pack, PVDF, threaded fittings, 1/2" BSP (Only for ReNu 20, ReNu 60, ReNu 120 and ReNu CWT pumpheads. Not available for ReNu 30 pumpheads)</p>	<p>0M9.401H.F03</p>
	<p>Hydraulic connection pack, PVDF, threaded fittings, 1/2" NPT (Only ReNu 20, ReNu 60, ReNu 120 and ReNu CWT pumpheads. Not available for ReNu 30 pumpheads)</p>	<p>0M9.401H.F04</p>
	<p>Hydraulic connection pack, PVDF, 1/2" hose barb</p>	<p>0M9.401H.F05</p>
	<p>Interface tubing, pvc 6.3x11.5mm, 2m (6.5ft) length</p>	<p>0M9.2222.V6B</p>

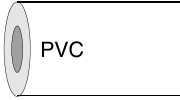
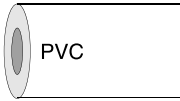
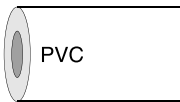
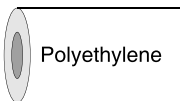
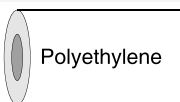
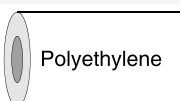
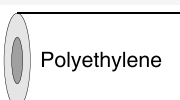








Image	Description	Part number
 <p>PVC</p>	Interface tubing, pvc 10x16mm, 2m (6.5ft) length	0M9.2222.VAD
 <p>PVC</p>	Interface tubing, pvc 6.3x11.5mm, 5m (16ft) length	0M9.2225.V6B
 <p>PVC</p>	Interface tubing, pvc 10x16mm, 5m (16ft) length	0M9.2225.VAD
 <p>Polyethylene</p>	Interface tubing, polyethylene 9x12mm, 2m (6.5ft) length	0M9.2222.E9C
 <p>Polyethylene</p>	Interface tubing, polyethylene 5x8mm, 2m (6.5ft) length	0M9.2222.E58
 <p>Polyethylene</p>	Interface tubing, polyethylene 9x12mm, 5m (16ft) length	0M9.2225.E9C
 <p>Polyethylene</p>	Interface tubing, polyethylene 5x8mm, 5m (16ft) length	0M9.2225.E58
	Replacement baseplate	0M9.223M.X00
	Input lead, M12 IP66, 3m (10ft) length	0M9.203X.000
	Output lead, M12 IP66, 3m (10ft) length	0M9.203Y.000

Image	Description	Part number
	HMI protective cover	0M9.203U.000
	ReNu Connection Collar - Qty 2	0M9.001H.P00
	ReNu 30, pack of 2 Viton "O" Rings	0M9.221R.K00
	ReNu 20, ReNu 60, ReNu 120 and ReNu CWT Santoprene Insert	0M9.001R.M00
	Qdos 30 pumphead clamp and screw (Pair)	0M9.203C.000

31 Performance data

31.1 Pumping conditions

For precise and repeatable performance it is important to calibrate your pump on a regular basis.

Actual flow rates achieved may vary to those displayed on the screen because of changes in temperature, viscosity, inlet and discharge pressures, system configuration and pumphead performance against time. For the highest accuracy it is advisable to calibrate the pump on a regular basis.

Where discharge pressures are quoted, they are the root mean square (RMS) discharge line pressures.

31.2 Pressure capability

qdos120 can be operated continuously at discharge pressures of up to 4 bar (60psi).

qdos60 can be operated continuously at discharge pressures of up to 7 bar (100psi).

qdos30 can be operated continuously at discharge pressures of up to 7 bar (100psi).
qdos30 can be operated at discharge pressures of up to 10 bar (145 psi), however flow rate and pumphead life will be affected.

qdos20 can be operated continuously at discharge pressures of up to 7 bar (100psi).
qdos20 PU can be operated continuously at discharge pressures of up to 4 bar (60psi).

qdos CWT can be operated continuously at discharge pressures of up to 7 bar (100psi).

31.3 Dry running

The pump will continue to operate when there is gas present in the suction line and will maintain prime in these conditions. The pump can be run dry, however flow rate and pumphead life will be affected.

31.4 Pumphead life

Application factors that influence pumphead life are pump speed, chemical compatibility and viscosity of the duty fluid and suction and discharge pressure.

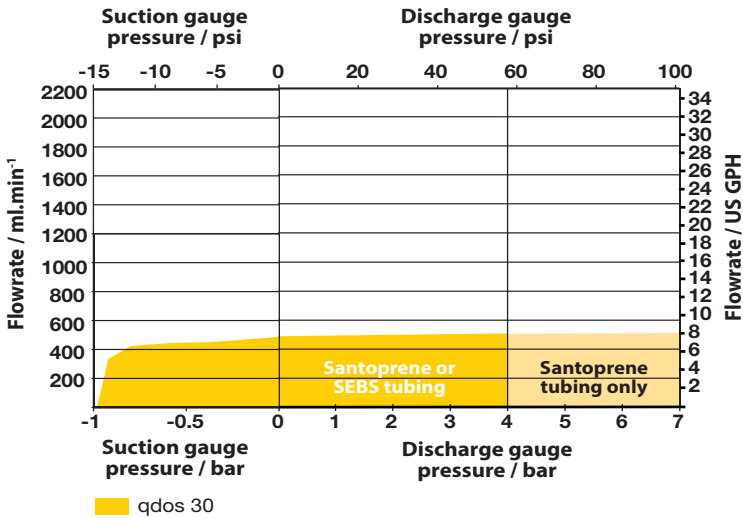
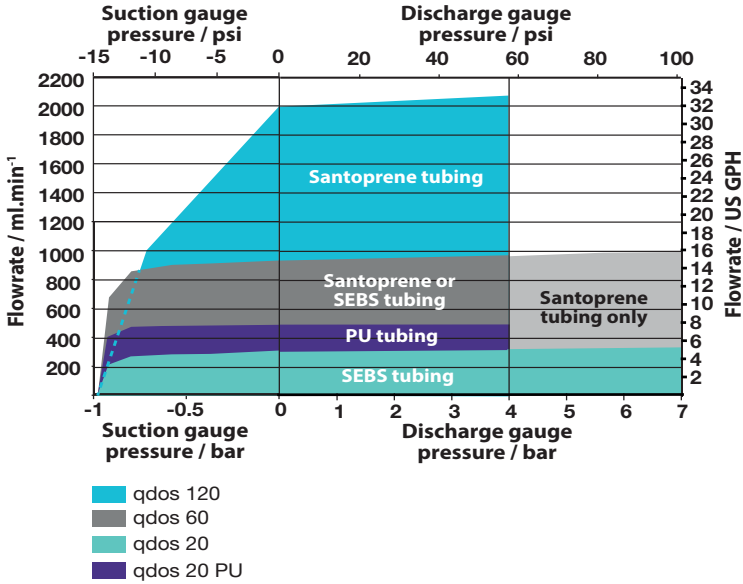
31.5 DC power supply option - input characteristics

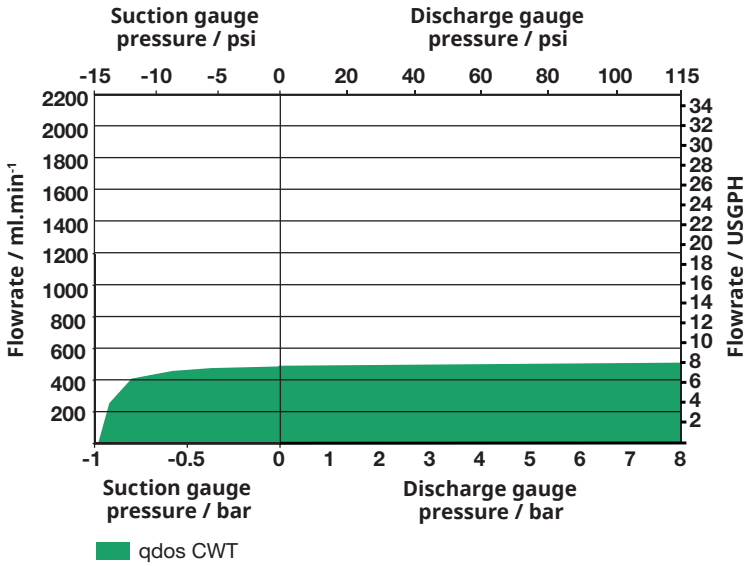
Parameter input supply	Limits			Units	Comment
	Min	Nom	Max		
Operating limits at cable ring terminals	10.4		32.0	VDC	At full discharge/charge
Maximum rated input current		15.2		A	At 10.5V/130W
Maximum rated input current		9.5		A	At 24V/200W
Inrush current		17		A	No Load
Inrush current duration		20		mS	
Efficiency @ ring terminals	87	91	95	%	100W@10/12/24V

Parameter input supply	Limits			Units	Comment
	Min	Nom	Max		
Typical qdos pump power required	5		120	W	qdos 20, 30, 60, 120, CWT
Maximum rated input power			200	W	qdos 20, 30, 60, 120, CWT

31.6 Performance curves

The graphs below show flow rates for suction and discharge pressures for the pumphead.





32 Trademarks

Watson-Marlow, qdos, qdos20, qdos30, qdos60, qdos120, qdos CWT and ReNu are trademarks of Watson-Marlow Limited.

33 Publication history

m-qdos-en-04

Watson-Marlow qdos 20, 30, 60, 120 User Manual

First published 11 2019

m-qdos-en-05

Watson-Marlow qdos 20, 30, 60, 120 and CWT User Manual

Updated to include qdos CWT models.

Updated to include 4 relay models.

First published 02 2020