

SPECIFICATION

1. Design Standard : ASME B 16.34
2. Process Connection : 1" FNPT (ASME B 1.20.1)
3. Instrument Connection : 1" FNPT (ASME B 1.20.1)
4. Vent Connection : 1/2" FNPT (ASME B 1.20.1)
5. TEMP. Rating : -20 ~ 150 °C
6. Pressure Test (API-598)
 - Design Pressure : 19.0 bar
 - Seat Test Pressure : 20.9 bar
 - Shell Test Pressure : 28.5 bar
7. Anti-static, Anti Blow-out Stem, Locking Device
8. Bore : 14mm
9. Unit : mm

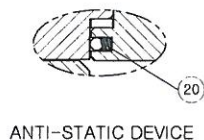

ANTI-STATIC DEVICE

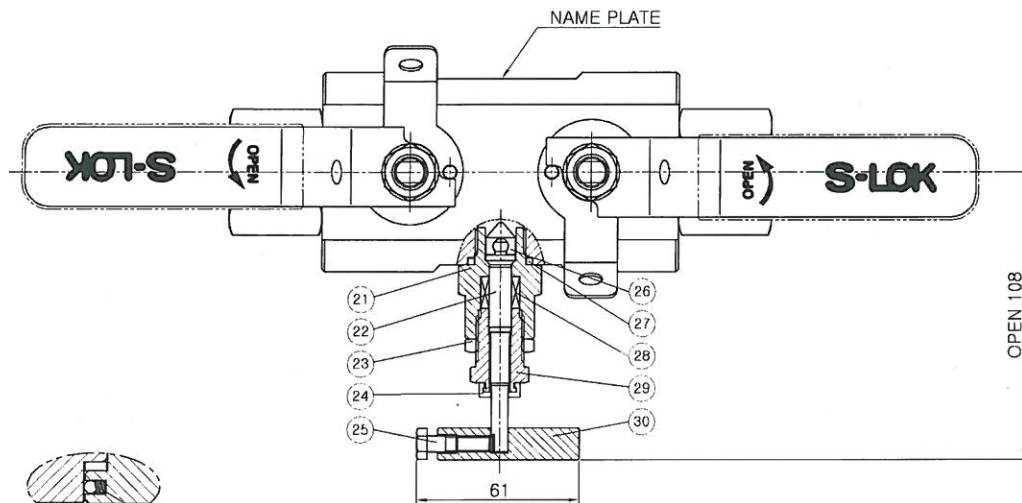
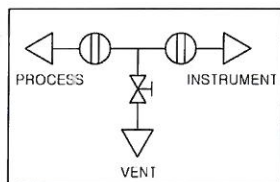
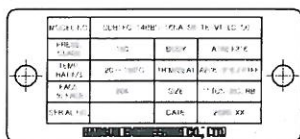

NAME PLATE

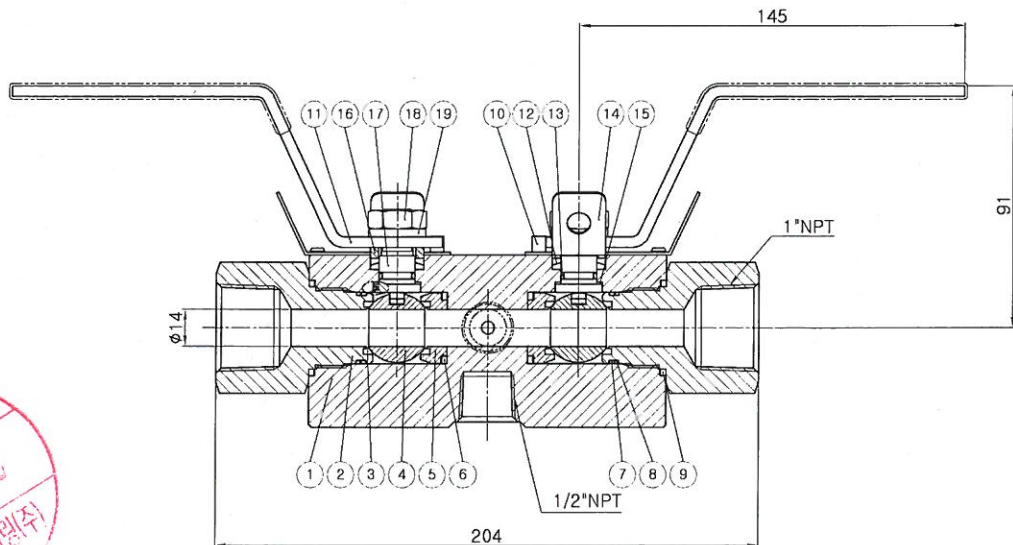

NO.	Part Name	Material	Qty	Remark
1	Body	A182 F316	1	
2	End Connector	A276-316	2	
3	Ball Seat	PTFE	4	
4	Floating Ball	A276-316	2	
5	Ball Seat Retainer	A276-316	2	
6	Retainer Seal	PTFE	2	
7	O-ring	VITON	2	
8	Backup-ring	PTFE	2	
9	End Connector Seal	PTFE	2	
10	Stop Pin	A276-316	4	
11	Packing Gland	A276-316	2	
12	Stem Packing	PTFE	2 SET	
13	O-ring	VITON	2	
14	Locking Plate	A240-304	2	
15	Thrust Washer	PEEK	2	
16	Primary Handle	A240-304	1	
17	Stem	A276-316	2	
18	Stem Nut	Stainless Steel	2	
19	Spring Washer	Stainless Steel	2	
20	Anti-static Device	Stainless Steel	2 set	
21	Needle Bonnet	A276-316	1	
22	Needle Stem	A276-316	1	
23	Lock Nut	A276-316	1	
24	Dust Cap	Silicon	1	
25	Hex Bolt	SS316	1	
26	Vee-Tip	A564-630	1	
27	Bonnet Seal	PTFE	1	
28	Needle Packing	PTFE	1 set	
29	Packing Bolt	A276-316	1	
30	Bar Handle	A276-316	1	



NO.	DESCRIPTION	DATE
<p>S-LOK® 한선엔지니어링(주) HANSUN ENGINEERING CO., LTD.</p>		
<p>TITLE DOUBLE BLOCK & BLEED VALVES BODY (BORE-14) 1" FNPT, CLASS 150</p>		
DATE	2020. 05. 15	DWG. S.H.Ahn
SCALE	N/S	CHECK H.P.Seo
SHEET No.	1/1	APP. S.M.Lee
DWG. No.	SDB1FC-14BBN-16NA-S6-1E-VI-LD-S6	REV. 0
CUSTOMER APPROVED		

Application & Installation

Solution

S-LOK instrumentation products has the ultimate solutions for a compact range one-piece forged body Primary Isolation Valves, featuring a choice of end connections, body styles and valve technology

Applications

- Double block and bleed instrument isolation
- Process piping isolation point
- Chemical injection systems
- Sampling systems
- Instrument Vents & drain
- Piping / instrument interface
- Direct mounting of instruments

Markets

- Offshore Oil & Gas
- Chemical Plant
- Petrochemical
- Power Generation
- LNG Carrier

Installation Advantages

- Compact design
- Provided weight & space savings.
- Reduced leakage points
- Reduced vibrational stresses.
- Supporting bracket are not required
- Reduced installation & maintenance costs

Design Standards

- ASME B 16.34 Valves-Flanged, Threaded, and Welding End
- ASME B 16.5 Pipe Flanges and Flanged Fittings
- ASME B 1.20.1 Pipe Threads, General Purpose
- API 607 / BS 6755 part 2 Fire test for Quarter-turn Valves
- ISO 15848-1 / 15848-2 Measurement, test and qualification procedures for fugitive emissions
- NACE MR 0175 / ISO 15156 General principles for selection of cracking-resistant materials

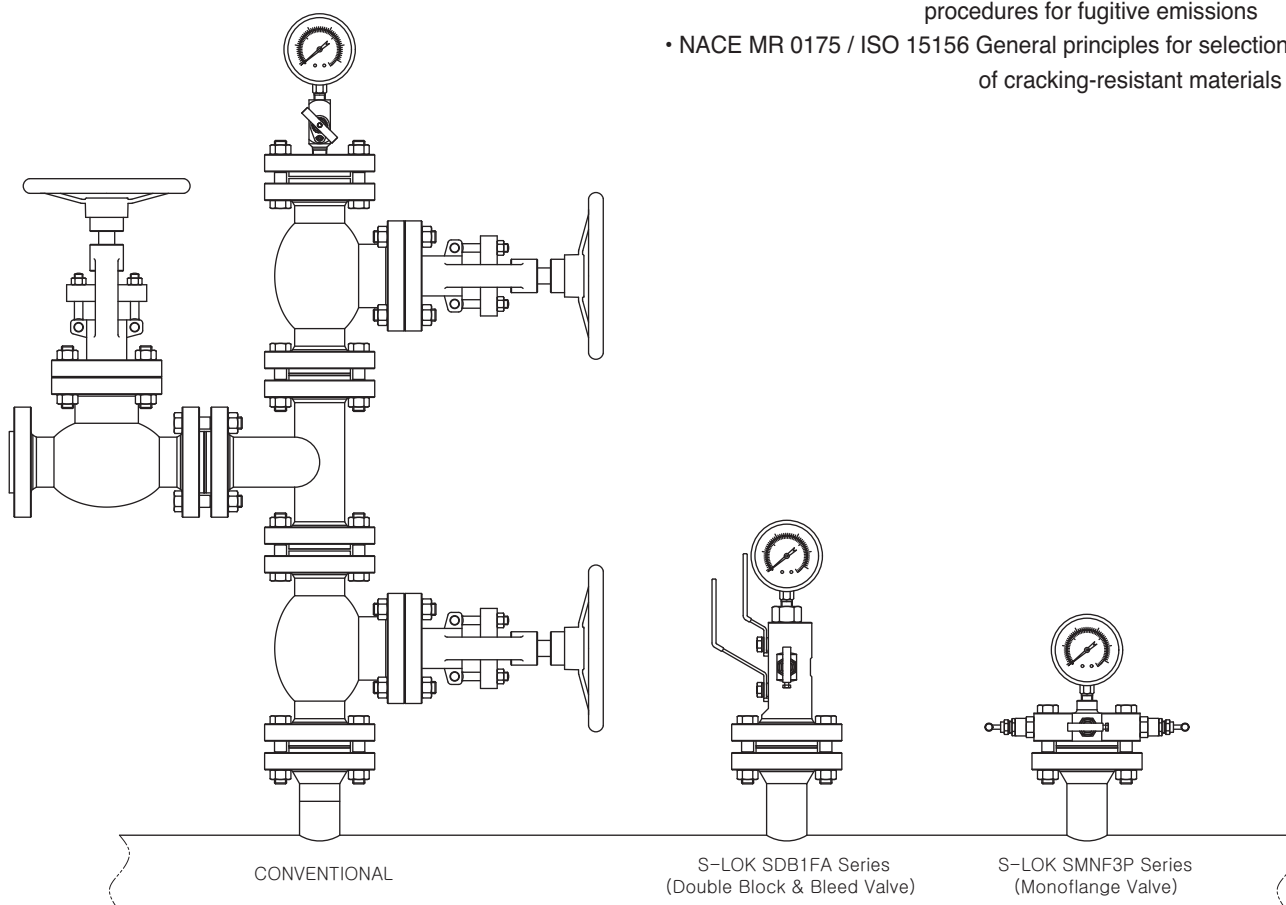

Specification

Standard Features

- ASME B 16.5 flanged connections 1/2" to 2" sizes.
- Class150 rated to Class2500 rated.
- API flanged connections sizes to 2-1/16".
- 1/2" ~ 1" NPT threaded female outlet / vent to ASME B1.20.1.
- Material thickness to ASME B16.34.
- Bolted Body construction (Inlet or Outlet) is options.
- Pressure test is in accordance with API 598
- Fire safe designed to API 607, BS6755 Part2.

Ball Valve Design

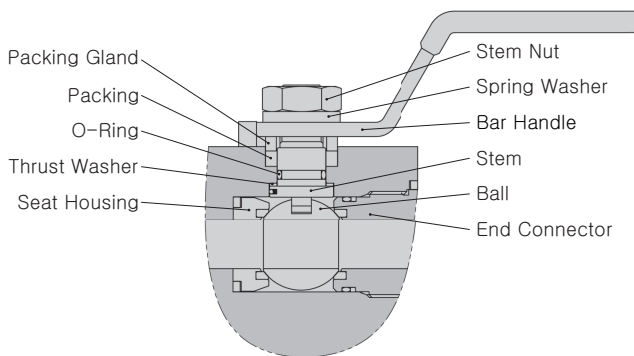

Features

- Blowout proof stem.
- Fully encapsulated allow high working pressure.
- Super finished ball for low operating torque and long life.
- End connector threads are fully isolated from process by primary and secondary static seals.
- Color coded and function identified handles.
- Bore size available 10mm (3/8"), ~ 50mm (2").
- Ball seats choice of materials : PTFE(virgin or filled), PEEK.
- Anti-static design as standard
- Pressure rating up to 10,000psig(690bar).
- Temperature rating -70.6°F to 482°F(-57°C TO 250°C).
- Optional : NACE Compliance, Handle Locking Device.

Materials of Construction

Description	Material Grade		
	Stainless Steel	Lower Temp. Carbon Steel	Duplex Stainless Steel
Body / Connector	A182 F316/316L	A350 LF2	A182 F51
Ball	A479-316/316L		UNS S31803
Stem	A479-316		UNS S31803
Seat	PTFE / R.PTFE / PEEK		
Thrust Washer	PEEK		
O-Ring	NBR / VITON (FKM)		
Packing / Seal	GRAPHIITE		
Bolt / Nut	A193 B8M Cl.2 / A194 8M	A320 L7M / A194 7	A453-660
All other part	Stainless steel 316		

NOTE

Stainless steel is standard body material but such a Monel, Super Duplex, Hastelloy, Inconel and other special material are available upon request

Needle Valve Design

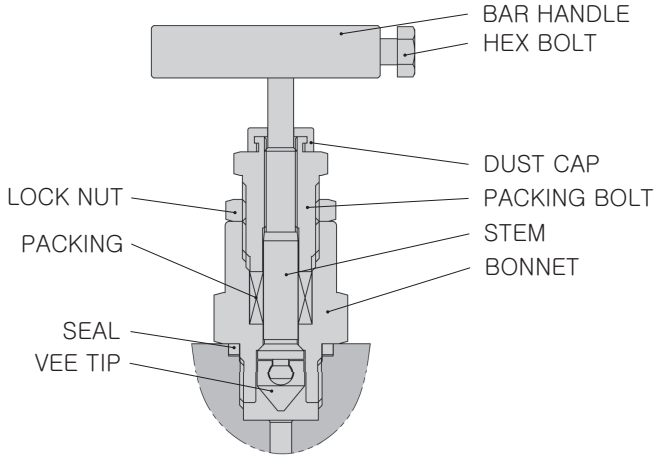

- Stem threads are completely isolated from the process.
- Bolted bonnet for strength and reliability.
- Flange gasket seal ensures a bubble-tight between body & bonnet
- Adjustable gland flange allows easy access to the packing gland and packing adjustment for an effective stem seal.
- Investment cast yoke is precision casted for strength and perfect stem alignment.

Features

- Rolled stem threads prevent galling. Stem threads are completely isolated from the process.
- Stem packing with Graphite or PTFE rings for bubble-tight seal.
- Stem tip construction : non-rotating self-centering, Anti-galling tip positive bubble-tight and field interchangeable rip.
- Backseat design provides secondary stem sealing & prevents stem blowout.
- Packing bolt allows easy access to adjust the packing gland.
- Robust bar handle is standard.
- Color coded and function label for easy identification.
- Orifice size 0.2"(5mm).
- Pressure rating up to 10,000psig(690bar).
- Temperature rating -70.6°F to 1,022°F (-57°C to 550°C)
- Anti-Temper bonnets are available with a removable T-bar key to prevent unauthorized operation of vent valves.
- Standard valves are offered with Graphite. PTFE is also available as an option

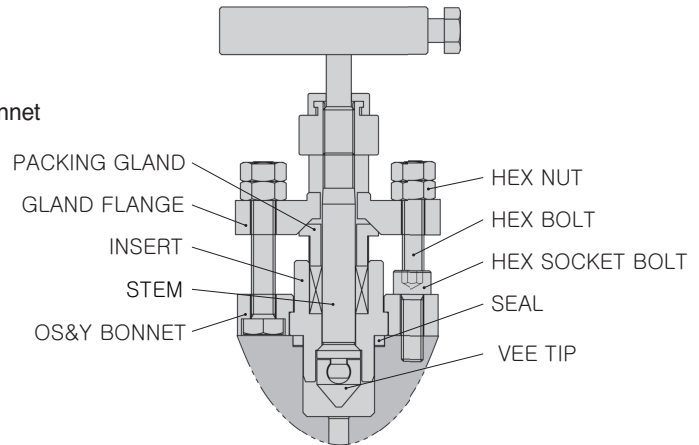

Materials of Construction

Description		Material Grade		
		Stainless Steel	Lower Temp. Carbon Steel	Duplex Stainless Steel
Bonnet	Bolted	A182 F316/316L	A350 LF2	UNS S31803
	OS&Y	A351 CF8M	A352 LCC	
Vee Tip		A564-630		UNS S31803
Stem		A479-316		UNS S31803
Insert		A276-316		UNS S31803
Packing / Seal		GRAPHIITE		
Bolt / Nut		A193 B8M Cl.2 / A194 8M	A320 L7M / A194 7	A453-660
All other part		Stainless steel 316		

NOTE

Stainless steel is standard body material but such a Monel, Super Duplex, Hastelloy, Inconel and other special material are available upon request

Block & Bleed Valves

SSB1FA Series

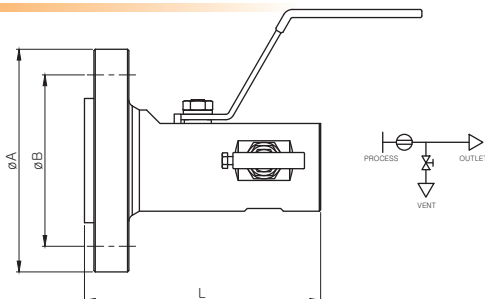

SDB1FA Series

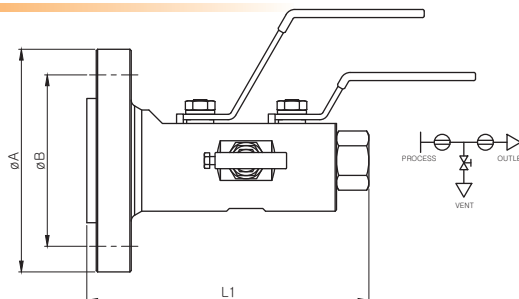

SSB1FA Series

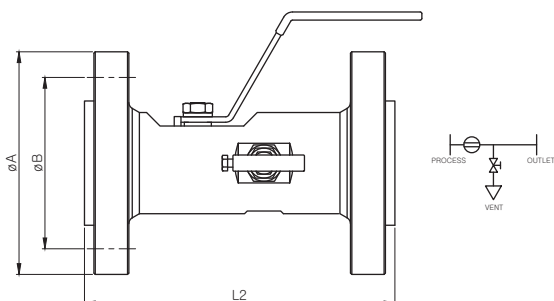

SDB1FA Series

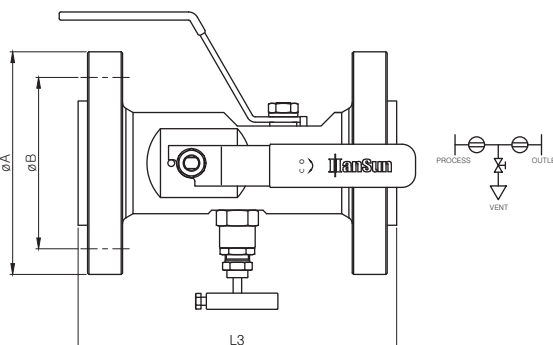

Dimensions (Bore-10)

SIZE (Inch)	RATING (Class)	DIMENSIONS(mm)					
		L (RF)	L1 (RF)	L2 (RF)	L3 (RF)	A	B
1/2	150	130	165	160	185	90	60.3
	300	135	170	165	190	95	66.7
	600	140	175	180	205	95	66.7
	900/1500	155	195	205	235	120	82.6
	2500	165	200	225	250	135	88.9
3/4	150	135	170	160	190	100	69.9
	300	135	175	175	200	115	82.6
	600	145	180	190	215	115	82.6
	900/1500	160	195	215	240	130	88.9
	2500	165	205	225	255	140	95.2
1	150	135	170	165	195	110	79.4
	300	140	180	180	205	125	88.9
	600	150	185	195	225	125	88.9
	900/1500	165	205	225	255	150	101.6
	2500	170	210	240	270	160	108.0
1 1/2	150	140	175	170	200	125	98.4
	300	145	185	185	215	155	114.3
	600	155	190	205	235	155	114.3
	900/1500	175	215	245	275	180	123.8
	2500	190	230	285	310	205	146.0
2	150	145	180	180	210	150	120.7
	300	150	185	185	215	165	127.0
	600	155	190	205	235	165	127.0
	900/1500	175	215	245	275	215	165.1
	2500	195	235	295	315	235	171.4

* Dimensions are for reference only and are subject to change.

Dimensions (Bore-14)

SIZE (Inch)	RATING (Class)	DIMENSIONS(mm)					
		L (RF)	L1 (RF)	L2 (RF)	L3 (RF)	A	B
3/4	150	150	185	175	210	100	69.9
	300	155	195	185	225	115	82.6
	600	160	200	200	235	115	82.6
	900/1500	175	215	225	260	130	88.9
	2500	180	220	240	275	140	95.2
1	150	150	185	175	215	110	79.4
	300	155	195	190	225	125	88.9
	600	165	205	205	245	125	88.9
	900/1500	180	220	240	275	150	101.6
	2500	185	225	250	290	160	108.0
1 1/2	150	155	190	180	220	125	98.4
	300	160	200	200	235	155	114.3
	600	170	210	220	255	155	114.3
	900/1500	190	230	255	300	180	123.8
	2500	210	245	285	330	205	146.0
2	150	160	195	190	230	150	120.7
	300	160	200	200	235	165	127.0
	600	170	210	220	255	165	127.0
	900/1500	190	230	265	305	215	165.1
	2500	210	250	300	345	235	171.4

* Dimensions are for reference only and are subject to change.

Dimensions (Bore-20)

SIZE (Inch)	RATING (Class)	DIMENSIONS(mm)			
		L1 (RF)	L3 (RF)	A	B
1 1/2	150	230	230	125	98.4
	300	235	250	155	114.3
	600	245	270	155	114.3
	900/1500	270	315	180	123.8
	2500	305	375	205	146.0
2	150	230	245	150	120.7
	300	235	250	165	127.0
	600	245	270	165	127.0
	900/1500	270	315	215	165.1
	2500	310	380	235	171.4

* Dimensions are for reference only and are subject to change.

SDB3FB Series

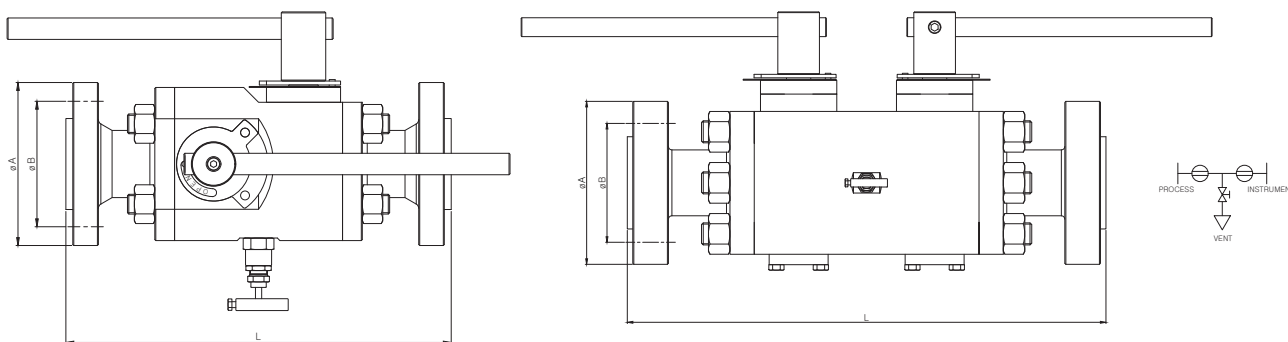

Dimensions (Reducing Bore)

SIZE (Inch)	RATING (Class)	DIMENSIONS(mm)		
		L (RF)	A	B
1	150	260	110	79.4
	300	275	125	88.9
	600	295	125	88.9
	900/1500	365	150	101.6
	2500	430	160	108.0
1 1/2	150	275	125	98.4
	300	290	155	114.3
	600	330	155	114.3
	900/1500	430	180	123.8
	2500	480	205	146.0
2	150	320	150	120.7
	300	330	165	127.0
	600	390	165	127.0
	900/1500	465	215	165.1
	2500	550	235	171.4

* Dimensions are for reference only and are subject to change.

Dimensions (Full Bore)

SIZE (Inch)	RATING (Class)	DIMENSIONS(mm)		
		L (RF)	A	B
1 1/2	150	310	125	98.4
	300	330	155	114.3
	600	395	155	114.3
	900/1500	460	180	123.8
	2500	540	205	146.0
2	150	335	125	98.4
	300	345	155	114.3
	600	435	155	114.3
	900/1500	520	180	123.8
	2500	690	205	146.0

* Dimensions are for reference only and are subject to change.

Block & Bleed Valves

Sampling Double Block & Bleed Valve

- Sampling the process stream can be accomplished with this valve design, where a sampling can be taken even at full system pressure directly from the process line. The product allows double isolations from process for safety
- The Sampling Probe length is manufactured to suit customer requirements

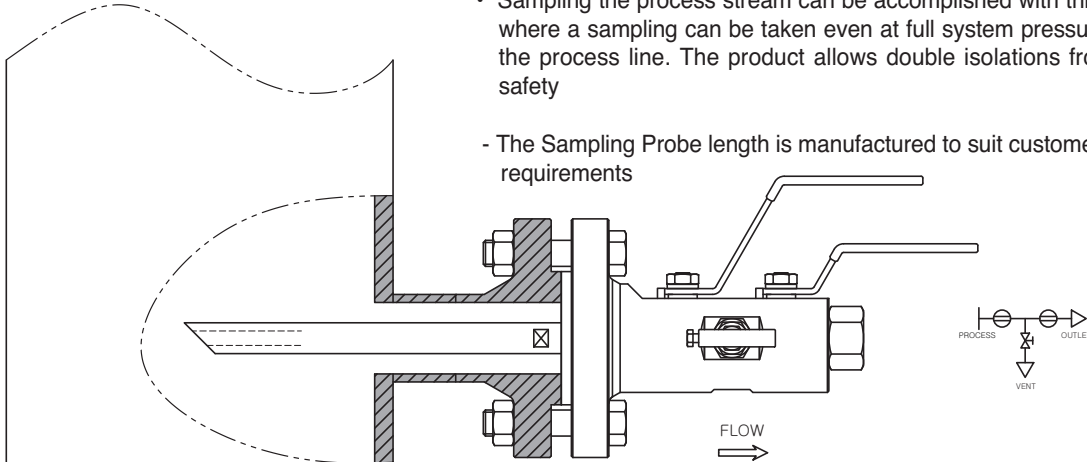

Injection Double Block & Bleed Valve

- Injection of chemicals and other media into the process stream can be accomplished with this valve design. The valve inlet houses a one way check valve which opens for injection and goes normally closed to eliminate process fluid outflow.
- The Injection Quill length is manufactured to suit customer requirements. The Injection Nozzle is a 3.2mm diameter hole. (Standard)

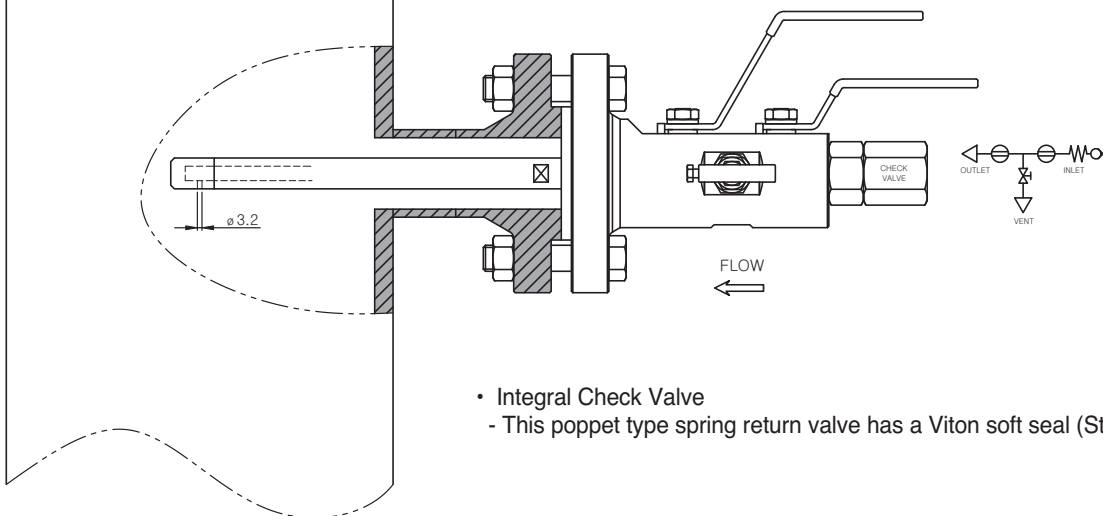

- Integral Check Valve
- This poppet type spring return valve has a Viton soft seal (Standard)

Ordering Information

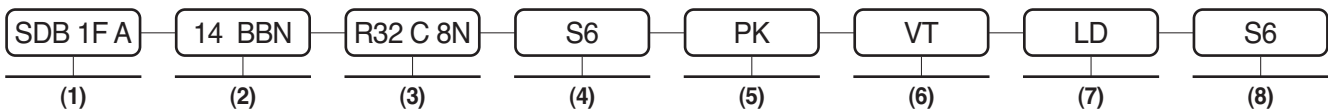

(1) Valve Model & Type

SSB : Single Block & Bleed (Floating)
SDB : Double Block & Bleed (Floating)
-T : Trunnion Mounted

1F : 1-piece Forged
2F : 2-piece Forged
3F : 3-piece Forged

A : Flanged x Female NPT
B : Flanged x Flanged
C : Female NPT x Female NPT
D : Male NPT x Female NPT

(2) Bore – Primary Valve – Secondary Valve – Vent Valve

10 : 10mm **32** : 32mm
14 : 14mm **38** : 38mm
20 : 20mm **50** : 50mm
25 : 25mm

B : Ball Valve
N : Needle Valve
O : OS & Y Needle Valve
G : Gate Valve

(3) Connection Detail (Inlet – Class – Outlet)

R- : RF (Raised Face)
F- : FF (Flat Face)
J- : RTJ (Ring Type Joint)
-N : NPT
-R : PT
-G : PF

8 : 1/2"
12 : 3/4"
16 : 1"
20 : 1-1/4"
24 : 1-1/2"
32 : 2"

A : CLASS 150
B : CLASS 300
C : CLASS 600
D : CLASS 900
E : CLASS 1500
F : CLASS 2500

(4)(8) Trim / Body Material

S6 : S316/316L
S6L : S316L
S4 : S304
D : S31803
SD : S31250

S630 : A564-630
A400 : Monel 400
A625 : Inconel 625
A825 : Inconel 825
S410 : A479-410

LF2 : A350 LF2 CL.1
105 : A105
15N : A105N
AB : AL-BRONZE

(5) Seat Material

TE : PTFE
T1 : GLASS 15% PTFE
T2 : GLASS 25% PTFE
T3 : CARBON 15% PTFE
T4 : CARBON 25% PTFE

PK : PEEK
PC : PCTFE
DEV : DEVLON
NY6 : NYLON-6
POM : POM

TCC : METAL (S316 + T.C.C)
ST6 : METAL (S316 + STELLITE 6)

(6) O-Ring Material

NBR : NBR
HNB : HNBR
VT : VITON

EP : EPDM
KA : KALREZ
-A : AED

(7) Option

FS : Fire Safety (Standard)
LD : Locking Device
AT : Anti-Tamper Key
SP : Sampling Probe
IQ : Injection Quill

FEA : Fugitive Class-A
FEB : Fugitive Class-B
WO : Welding Overlay
WP : Vent Plug
WF : Vent Flange

LBT : Long Bonnet
V4N : Vent 1/4" NPT