

MALE RUN TEES

75

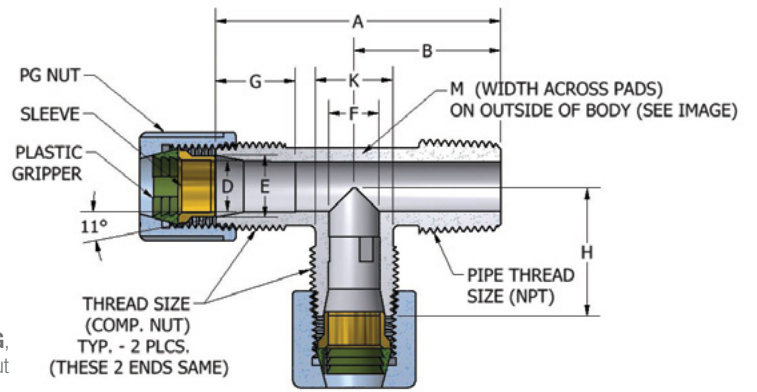

Diagram shown with Nut Style, PG, Plastic Gripper Nut

Male Run Tees

JACO Part No.	Tube O.D.	Pipe Thd. NPT	Comp. Thd.	A	B	D	E	F	G	H	K	M
75 - 4 - 2 - - -	1/4	1/8	7/16-20	±1/64	±1/64	+0.05						
75 - 4 - 4 - - -	1/4	1/4	7/16-20	1-15/32	3/4	.250	.330-.335	.170	15/32	47/64	3/8	23/64
75 - 5 - 4 - - -	5/16	1/4	1/2-20	1-21/32	15/16	.250	.330-.335	.170	15/32	47/64	3/8	3/8
75 - 6 - 4 - - -	3/8	1/4	5/8-20	1-3/16	1-1/64	.312	.380-.385	.232	31/64	13/16	7/16	7/16
75 - 6 - 6 - - -	3/8	3/8	5/8-20	2	1-3/64	.375	.460-.465	.250	19/32	31/32	35/64	35/64
75 - 8 - 6 - - -	1/2	3/8	3/4-20	2-1/8	1-3/32	.375	.460-.465	.250	19/32	31/32	37/64	37/64
75 - 8 - 8 - - -	1/2	1/2	3/4-20	2-1/4	1-9/64	.500	.590-.595	.375	11/16	1-7/64	11/16	11/16
75 - 8 - 8 - - -	1/2	1/2	3/4-20	2-3/8	1-9/32	.500	.590-.595	.375	11/16	1-3/32	21/32	43/64
75 - 10 - 8 - - -	5/8	1/2	7/8-20	2-47/64	1-15/32	.625	.715-.720	.500	45/64	1-1/4	13/16	13/16
75 - 12 - 8 - - -	3/4	1/2	1-1/16-20	3-3/16	1-39/64	.750	.860-.865	.625	13/16	1-37/64	1	1-3/64
75 - 12 - 12 - - -	3/4	3/4	1-1/16-20	3-3/16	1-5/8	.750	.860-.865	.625	13/16	1-9/16	1	1-3/64
75 - 14 - 12 - - -	7/8	3/4	1-3/16-16	3-3/16	1-5/8	.875	.995-.1.000	.750	7/8	1-9/16	1-1/8	1-3/16