

MS8 Seal - Pressure Gauge Assembly

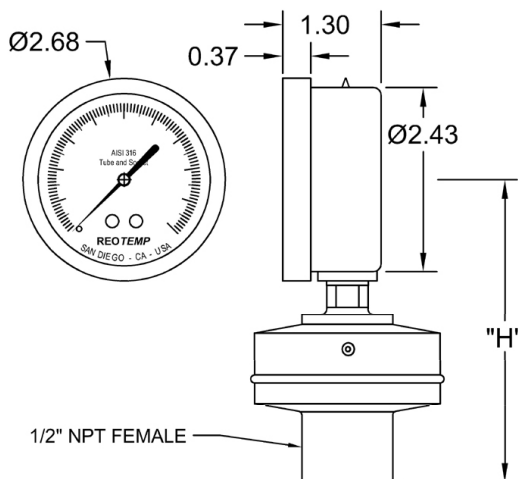

Part #:	MS8P2AF2XP04-SDDDASXDP
---------	------------------------

Gauge Data:	
Gauge Type:	2.5" Dial, 304SS case, Bottom Mount
Compound Range:	-30in Hg/0/60psi
Case Material:	304SS
Gauge Internals:	316SS
Lens Material:	Clear Plastic
Case Fill:	None (Dry)

Seal Data:	
Seal-to-Process Conn:	1/2" NPT female
Seal-to-Gauge Connection:	Direct mount
Wetted material:	316L SS
Diaphragm diameter:	2.2 in.
Seal Fill Fluid:	Silicone DC200®
Flushing Connection:	None
Gasket Material:	None; all-welded construction

Options and Accessories:	(Options are not depicted in drawing)
--------------------------	---------------------------------------

Operating Limits:		min	max
Ambient Temp:	-40°F	150°F	
Process Temp:	-40°F	250°F	
Max Working Pressure:	60 psi		
Proof Pressure at 70°F:	78 psi		
Max. Process Fluid Containment Pressure @ 70°F:	3000 psi		

Drawing Dimensions:	
Height "H":	4 in.

Data generated on:	11/10/2020	Revision:	x1	Rev. Date*:	6/1/2013
--------------------	------------	-----------	----	-------------	----------

*Revision date applies to all possible data: Individual drawings may not be affected. To obtain current revision, re-generate drawing at www.reotemp.com.

Made in U.S.A.

File Control
MS8G-P2A
MS8U-DDDA
MS8L-XA
MS8P-F2A

Consult factory for critical dimensions.	REOTEMP Instrument Corporation 10656 Roselle Street San Diego, CA 92121 USA Phone: (858) 784-0710 Fax: (858) 784-0720	DRAWN BY: JR
Copyright 2013 REOTEMP Instruments		SIZE: B
THIS DRAWING AND SPECIFICATIONS ARE THE PROPERTY OF REOTEMP INSTRUMENT CORP., AND ARE ISSUED IN STRICT CONFIDENCE AND SHALL NOT BE REPRODUCED, COPIED OR USED AS THE BASIS FOR MANUFACTURE OR SALE OF ITEMS DEPICTED HEREIN WITHOUT WRITTEN PERMISSION FROM REOTEMP INSTRUMENT CORP.		CAGE CODE: 24793
		SCALE: NTS
		SHEET: 1 OF 1

Notes: Dimensions are in inches (unless otherwise noted) visit www.reotemp.com for attribution of trademarks.