

A&F MACHINE PRODUCTS CO.

Manufacturer of Helwig Chemical Feed Pumps and related water treatment equipment

1" PISTON HEAD ASSEMBLIES & PARTS

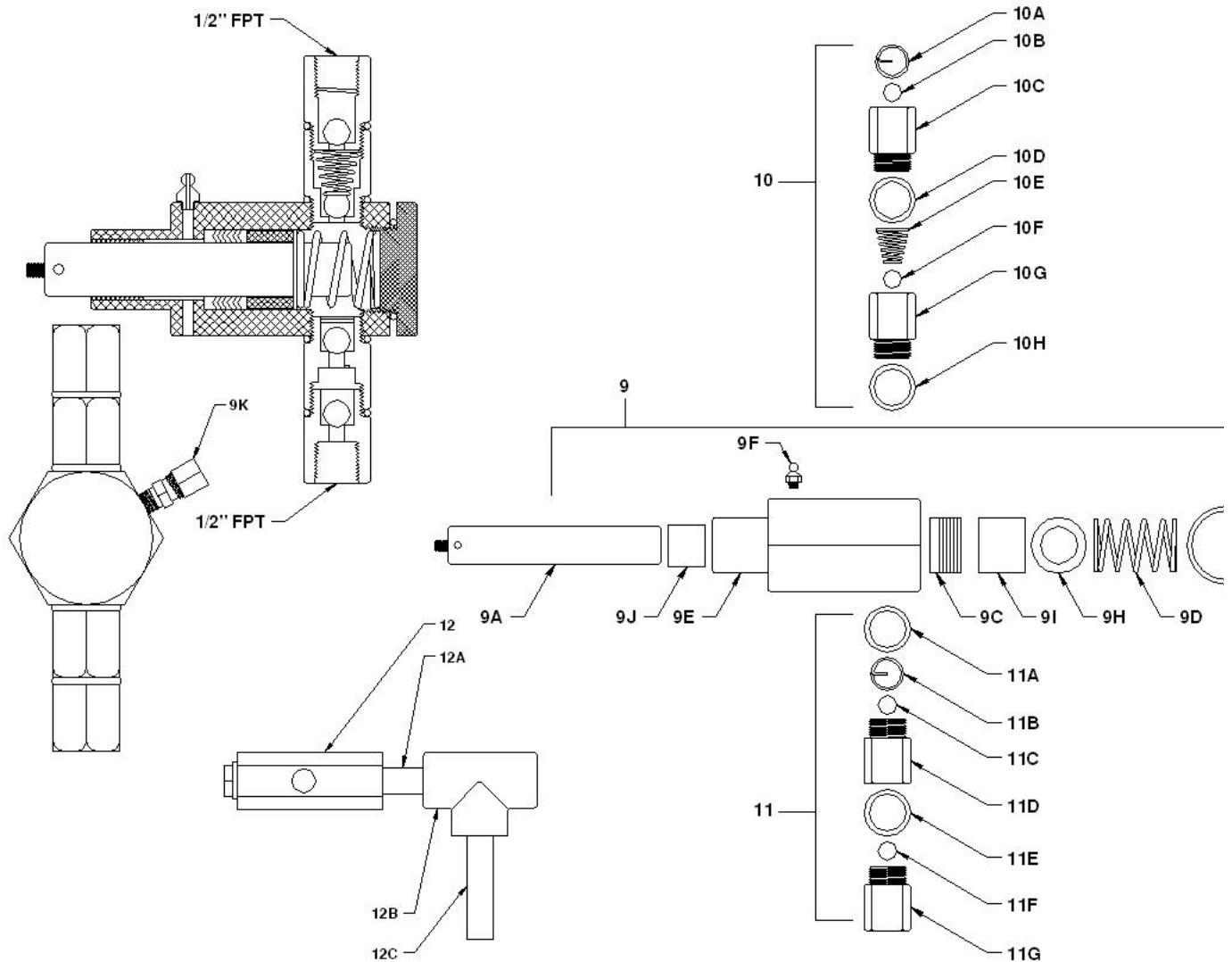

ITEM	PART #	DESCRIPTION
9	1000-6	1" CS PISTON HEAD ASSEMBLY** (LESS CKS)
9A*	007-7	1" DIAMETER 303SS PISTON***
9B	003-7	1" CS END CAP
9C*	012-7	1" PACKING SET (BUNA N)****
9D	017-10	1" PACKING SPRING
9E	001-7	1" CS PUMP HEAD SHELL**
9F	006-1	GREASE FITTING
9G*	017-9	1 7/8" ID X 1/8" CROSS SECTION "O" RING SEAL
9H	017-8	1" SS PACKING WASHER
9I	018-3	1" PACKING SPACER
9J	008-20	1 1/8" X 1" X 3/4" LONG OILITE BUSHING
9K	017-17-S	316SS VENT CHECK
10*	002-1"D	1" 303SS DISCHARGE CHECK VALVE ASSEMBLY***
10A	002-24	1/2" BALL RETAINER CLIP
10B	002-26	1/2" DIAMETER 316SS BALL CHECK
10C	002-20	1" TOP DISCHARGE CHECK BODY
10D	002-25	1" ID X 1/8" CROSS SECTION "O" RING SEAL

ITEM	PART #	DESCRIPTION
10E	002-27	ANTI-SYPHON CONE SPRING
10F	002-26	1/2" DIAMETER 316SS BALL CHECK
10G	002-21	1" BOTTOM DISCHARGE CHECK BODY
10H	002-25	1" ID X 1/8" CROSS SECTION "O" RING SEAL
11*	002-1"S	1" 303SS SUCTION CHECK VALVE ASSEMBLY***
11A	002-25	1" ID X 1/8" CROSS SECTION "O" RING SEAL
11B	002-24	1/2" BALL RETAINER CLIP
11C	002-26	1/2" DIAMETER 316SS BALL CHECK
11D	002-22	1" TOP SUCTION CHECK BODY
11E	002-25	1" ID X 1/8" CROSS SECTION "O" RING SEAL
11F	002-26	1/2" DIAMETER 316SS BALL CHECK
11G	002-23	1" BOTTOM SUCTION CHECK BODY
12	36	1/2" NPT 303SS PRESSURE RELIEF VALVE
12A		1/2" NPT X 1 1/2" BLACK NIPPLE
12B		1/2" NPT BLACK TEE
12C		1/2" NPT X 2 1/2" BLACK NIPPLE

* RECOMMENDED SPARE PARTS

CS-CARBON STEEL
C20-ALLOY 20

OPTIONAL MATERIALS

** 303SS
316SS
C20

*** 316SS
C20