

# MS8 Seal - Pressure Gauge Assembly

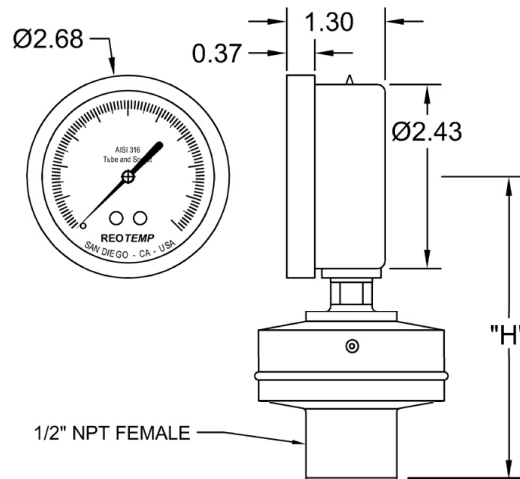

Part #:	MS8P2AF2XP21-SDDDASXDP
---------	------------------------

<b>Gauge Data:</b>	
Gauge Type:	2.5" Dial, 304SS case, Bottom Mount
Pressure Range:	0 - 300 psi
Case Material:	304SS
Gauge Internals:	316SS
Lens Material:	Clear Plastic
Case Fill:	None (Dry)

<b>Seal Data:</b>	
Seal-to-Process Conn:	1/2" NPT female
Seal-to-Gauge Connection:	Direct mount
Wetted material:	316L SS
Diaphragm diameter:	2.2 in.
Seal Fill Fluid:	Silicone DC200®
Flushing Connection:	None
Gasket Material:	None; all-welded construction

Options and Accessories:	(Options are not depicted in drawing)
--------------------------	---------------------------------------

<b>Operating Limits:</b>	min max	
	Ambient Temp:	-40°F 150°F
	Process Temp:	-40°F 400°F
	Max Working Pressure:	300 psi
	Proof Pressure at 70°F:	390 psi
<b>Max. Process Fluid Containment Pressure @ 70°F:</b>		3000 psi

<b>Drawing Dimensions:</b>	
Height "H":	4 in.

Data generated on:	11/10/2020	Revision:	x1	Rev. Date*:	6/1/2013
--------------------	------------	-----------	----	-------------	----------

\*Revision date applies to all possible data: Individual drawings may not be affected. To obtain current revision, re-generate drawing at [www.reotemp.com](http://www.reotemp.com).

Made in U.S.A.

File Control  
MS8G-P2A  
MS8U-DDDA  
MS8L-XA  
MS8P-F2A

Consult factory for critical dimensions.	REOTEMP Instrument Corporation <b>REOTEMP</b> INSTRUMENTS 10656 Roselle Street San Diego, CA 92121 USA Phone: (858) 784-0710 Fax: (858) 784-0720	DRAWN BY: JR SIZE: B CAGE CODE: 24793
Copyright 2013 REOTEMP Instruments	THIS DRAWING AND SPECIFICATIONS ARE THE PROPERTY OF REOTEMP INSTRUMENT CORP., AND ARE ISSUED IN STRICT CONFIDENCE AND SHALL NOT BE REPRODUCED, COPIED OR USED AS THE BASIS FOR MANUFACTURE OR SALE OF ITEMS DEPICTED HEREIN WITHOUT WRITTEN PERMISSION FROM REOTEMP INSTRUMENT CORP.	SCALE: NTS SHEET: 1 OF 1

Notes: Dimensions are in inches (unless otherwise noted) visit [www.reotemp.com](http://www.reotemp.com) for attribution of trademarks.