

HRT-310 Quick Start

[Packing List]



HRT-310



CA-0910



Software CD



Screw Driver
(1C016)

1. Introduction

The hardware wiring and detailed operation of HRT-310, users can refer to the user manual in the ICP DAS product CD (CD:\hart\gateway\HRT-310\manual).

The quick start is used to help users quickly understand HRT-310 how to convert Modbus communication to HART. The below demo will use a HRT-310 module (as HART master), one HART slave device and one PC to make a simple application as the below figure. The PC is prepared for the setting and operation of HRT-310.

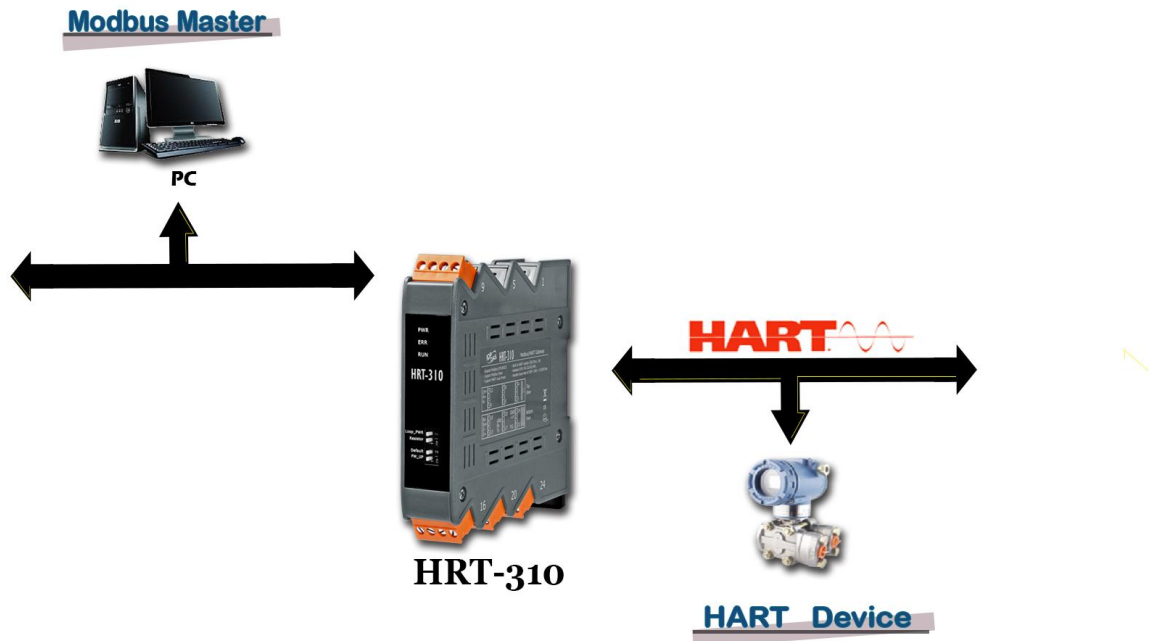

Figure1 : HRT-310 Application Structure

2. Hardware Configuration

2.1 Pin Assignment:



Pin	Name	Description
LP+	12	V+ of Loop Power (+24Vdc)
HART+	11	Positive of HART
HART-	10	Negative of HART
+VS	23	V+ of Power Supply (+10 ~ +30 Vdc)
GND	24	GND of Power Supply
RXD	18	Receive Data of RS-232
TXD	17	Transmit Data of RS-232
GND	19	GND of RS-232
RX+	15	Receive Data+ of RS-422
RX-	16	Receive Data- of RS-422

Pin	Name	Description
TX+	13	Transmit Data+ of RS-422
TX-	14	Transmit Data- of RS-422
D+	13	Data+ of RS-485
D-	14	Data- of RS-485

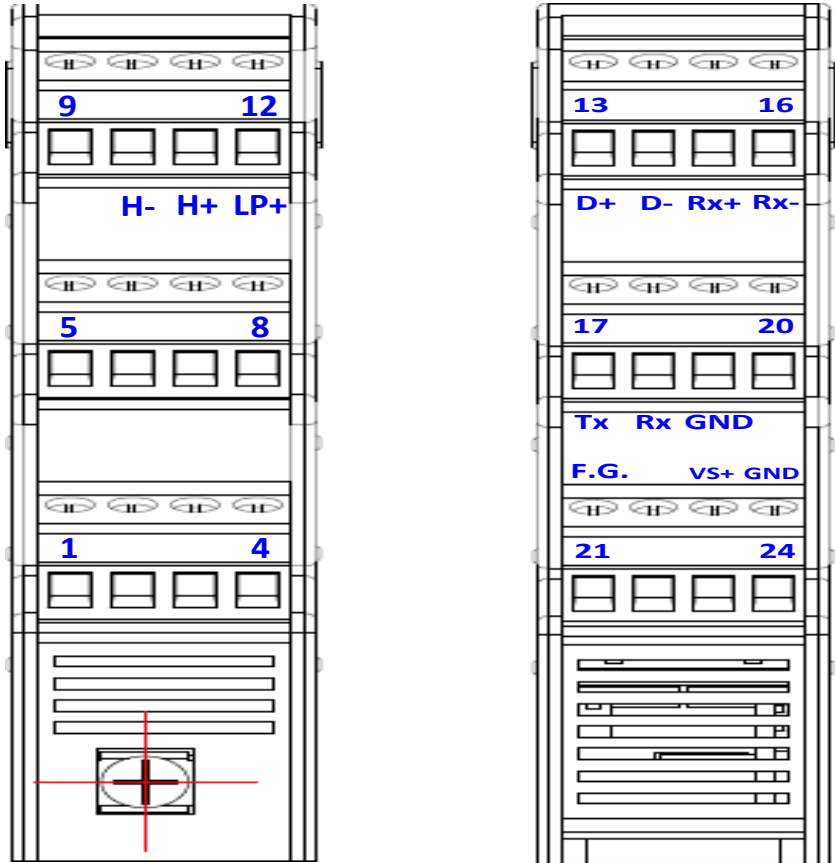

2.2 DIP Switch Setting

Please set the dip switch of the “Resistor” and “Default” to be ”ON” position.

Item	ON
Resistor	Enable HART loop resistor (250 Ohm, 1W)
Default	Adapt the default settings. (Refer to section 2.5.1)

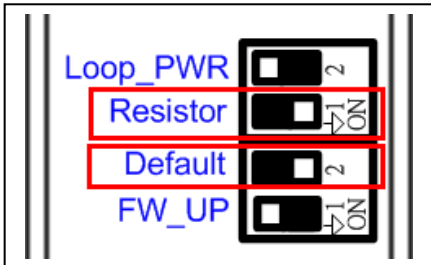

2.3 LED Indicator

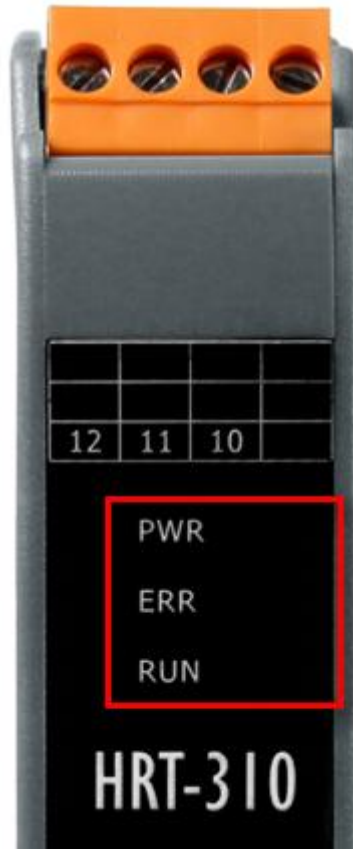

LED Name	Status	Description
PWR	ON	Module Power OK.
	OFF	Module Power Failed.
ERR	Flash	HART Comm. Error.
	OFF	HART Comm. OK
RUN	Flash	[Flash per second] Module in initial mode. [Flash per half second] Module received the burst frame from HART device.
	ON	Module in normal operation.
	OFF	Firmware has not been loaded yet.

2.4 RS-232 Wiring

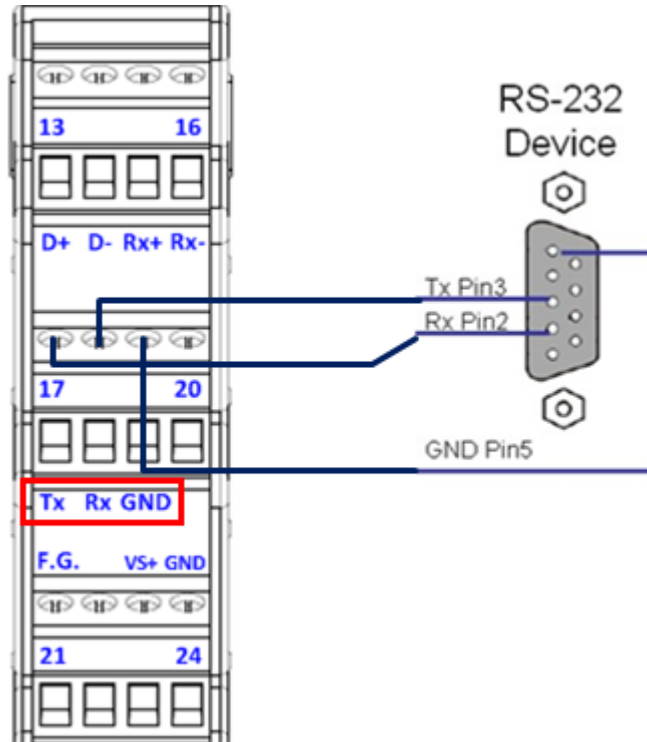

2.5 HART network wiring:

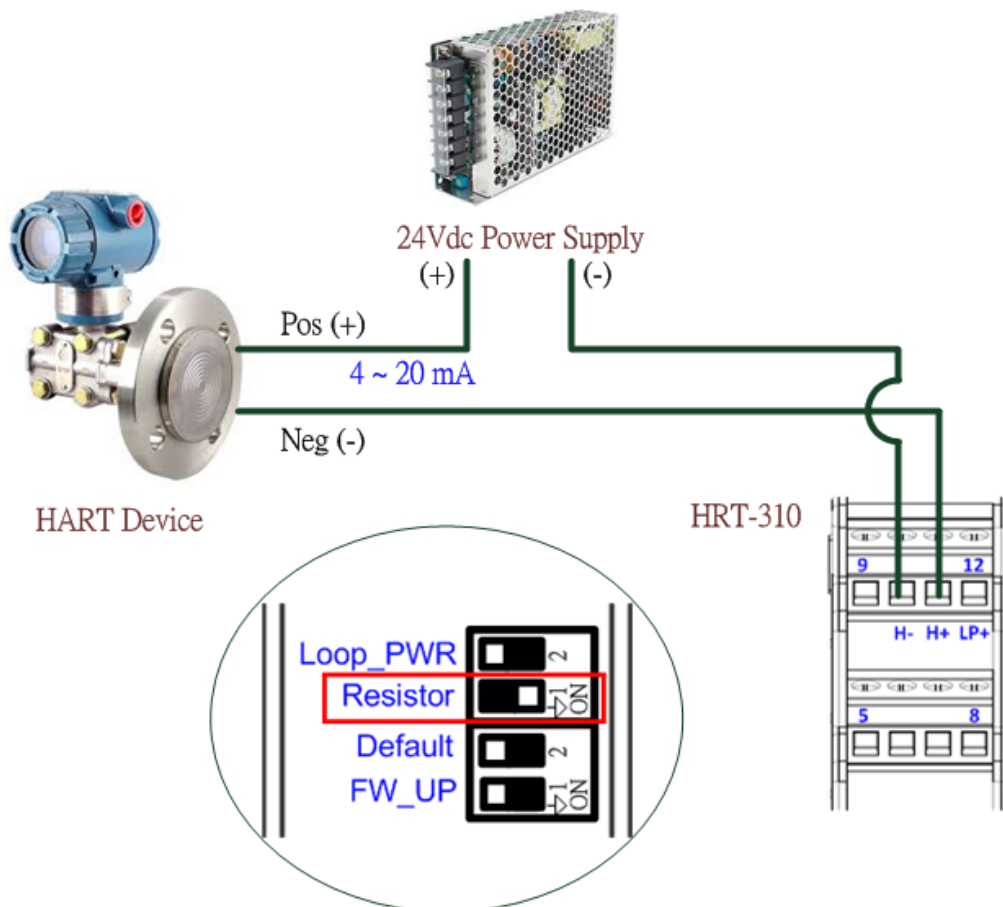

3. Install HG_Tool Utility

[Install .NET Compact Framework]

(1) When executing HG_Tool utility, the .NET Framework 2.0 or above must be installed first. If the .NET Framework 2.0 or above exists in the PC, please omit the step.

[Install HG_Tool.exe]

(1) Users can download the “HG_Tool” from the below source.

[1] CD_Disk => CD:\hart\gateway\utilities\hg_tool\”

[2] ftp://ftp.icpdas.com.tw/pub/cd/fieldbus_cd/hart/gateway/utilities/hg_tool/

(2) Execute the “setup.exe” file to install the “HG_Tool” utility.

(3) After finishing the installation of the HG_Tool, users can run the utility.
(refer to the path in the below figure)

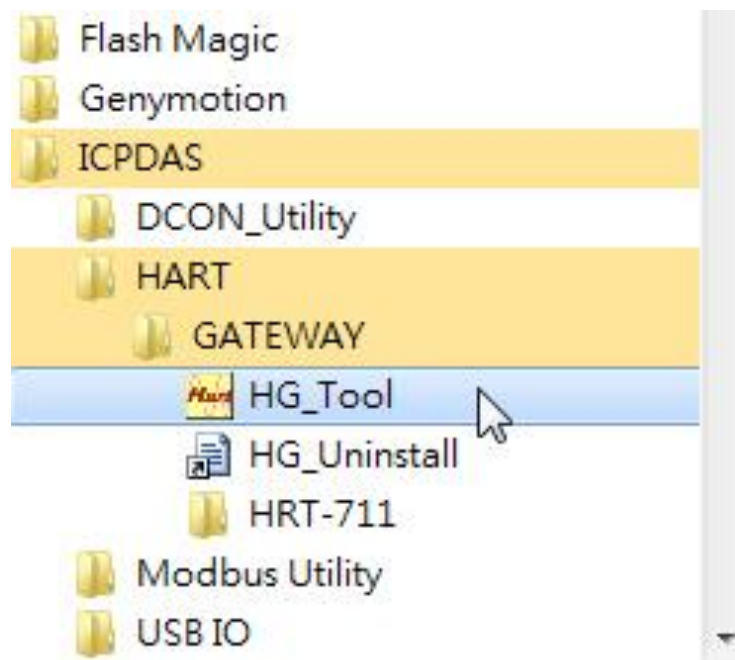

4. Communication Test

Step 1: Connect PC, HRT-310 and HART slave device according to figure1.

Step 2: Set the DIP switch of the “Default” to be “ON” position.

Step 3: Turn on the power of HRT-310.

Step 4: Wait for the “RUN” LED to be always on status. If the “RUN” LED always flashes, it means the HRT-310 can’t communicate with the HART device. Please check the HART network wiring.

Step 5: Execute the HG_Tool utility.

Step 6: Set the communication settings between PC and HRT-310.

When the DIP switch of the “Default” to be “ON” position, the HRT-310 will adopt the below comport communication settings.

- [1] Protocol: MB RTU
- [2] Net ID: 1
- [3] Baud Rate: 115200 bps
- [4] Data Bits: 8
- [5] Stop Bits: 1
- [6] Parity: None

=> So the HG_Tool must have the same settings with the HRT-310 as shown in the below figure.

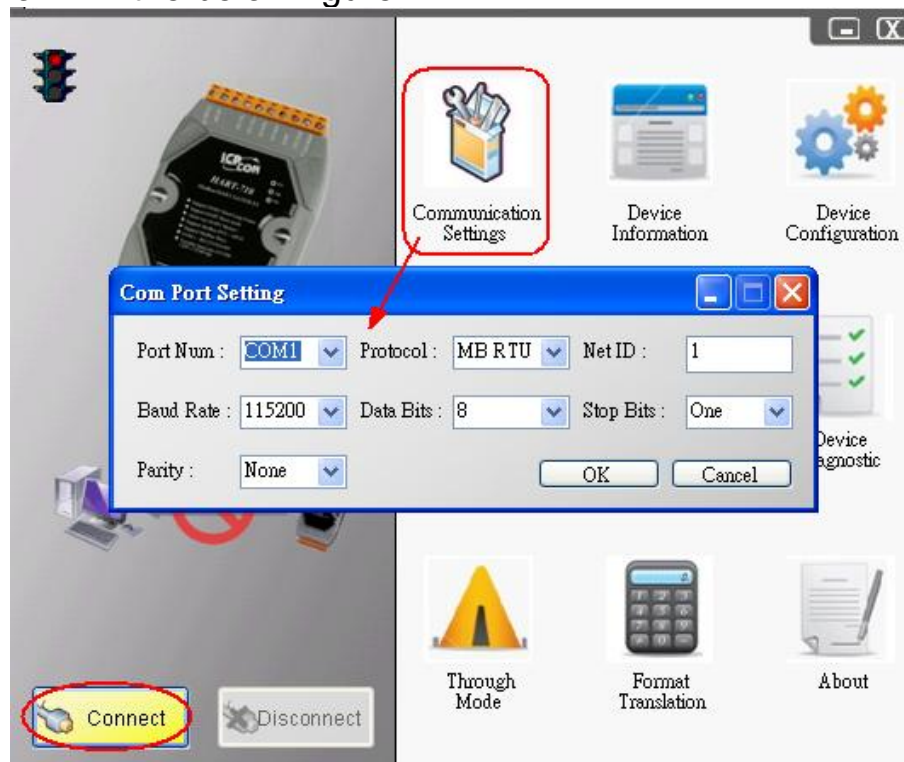

Step 7: Click “Connect” button.

Step 8: Wait for the traffic light from red light to “green” light. If the traffic light always keeps in the “yellow” light, it means the PC can’t connect to HRT-710, please check the RS-232 wiring.

Step 9: Click the “Device Information” icon. Then select the “Default CMD” or “User CMD” and right-click the mouse to choose the “Basic Operation” option to get the information of the corresponding HART command.

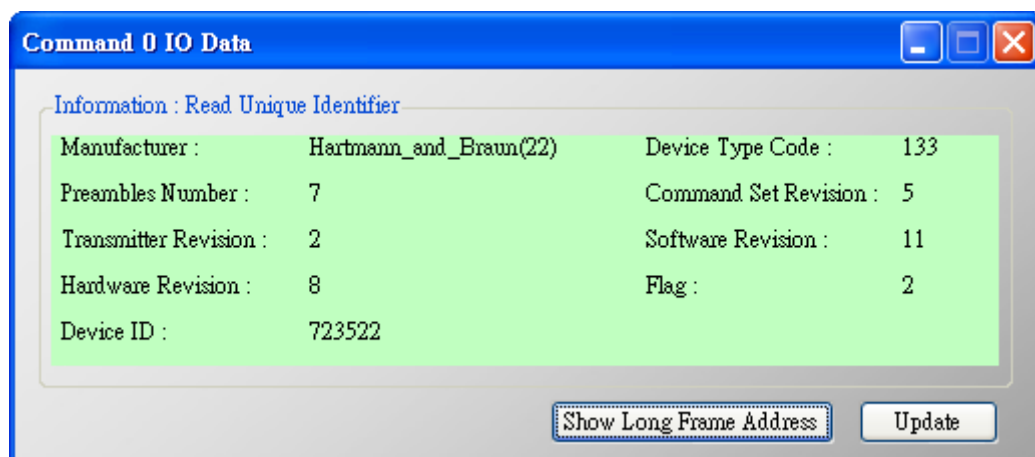
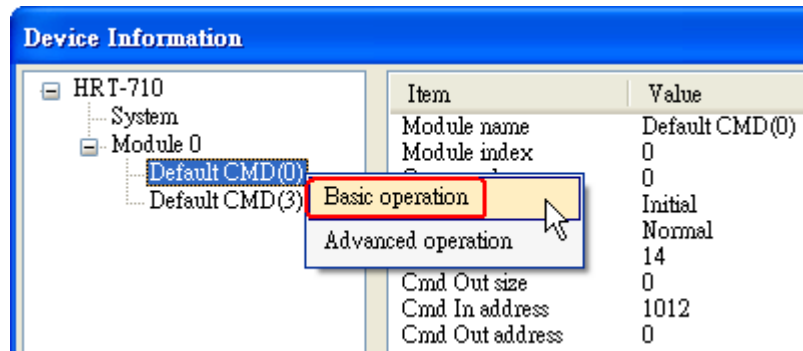

The information of HART command 0

[Note]

1. The detailed setting steps, please refer to the Q01 ~ Q03 of FAQ in the manual.