

DSCA34



Linearized 2- or 3-Wire RTD Input Signal Conditioners

Description

Each DSCA34 RTD input module provides a single channel of RTD input which is filtered, isolated, amplified, linearized, and converted to a high-level voltage output. Signal filtering is accomplished with a five-pole filter which provides 85dB of normal-mode rejection at 60Hz and 80dB at 50Hz. An anti-aliasing pole is located on the field side of the isolation barrier, and the other four poles are on the system side. After the initial field-side filtering, the input signal is chopped by a proprietary chopper circuit. Isolation is provided by transformer coupling, again using a proprietary technique to suppress transmission of common mode spikes or surges.

RTD excitation is provided from the module using a precision current source. Lead compensation is achieved by matching two current paths which cancels the effects of lead resistance. The excitation current is small (approx. 0.25mA) which minimizes self-heating of the RTD.

Module output is either voltage or current. For current output models a dedicated loop supply is provided at terminal 3 (+OUT) with loop return located at terminal 4 (-OUT). The system-side load may be either floating or grounded.

Special input circuits provide protection against accidental connection of power-line voltages up to 240VAC and against transient events as defined by ANSI/IEEE C37.90.1. Protection circuits are also present on the signal output and power input terminals to guard against transient events and power reversal. Signal and power lines are secured to the module using screw terminals which are in pluggable terminal blocks for ease of system assembly and reconfiguration.

The modules have excellent stability over time and do not require recalibration, however, zero and span settings are adjustable up to $\pm 3\%$ to accommodate situations where fine-tuning is desired. The adjustments are made using potentiometers located under the front panel label and are non-interactive for ease of use.

► Features

- Interfaces to 100 Ω Platinum or 120 Ω Nickel RTDs
- Linearizes RTD Signal
- Industry Standard Output of 0 to +10V, 0 to 20mA, or 4 to 20mA
- 1500Vrms Transformer Isolation
- ANSI/IEEE C37.90.1 Transient Protection
- Input Protected to 240VAC Continuous
- True 3-Way Isolation
- Wide Range of Supply Voltage
- 160dB CMR
- 85dB NMR at 60Hz, 80dB at 50Hz
- $\pm 0.08\%$ Accuracy
- $\pm 0.025\%$ Conformity
- Easily Mounts on Standard DIN Rail
- C-UL-US Listed
- CE and ATEX Compliant

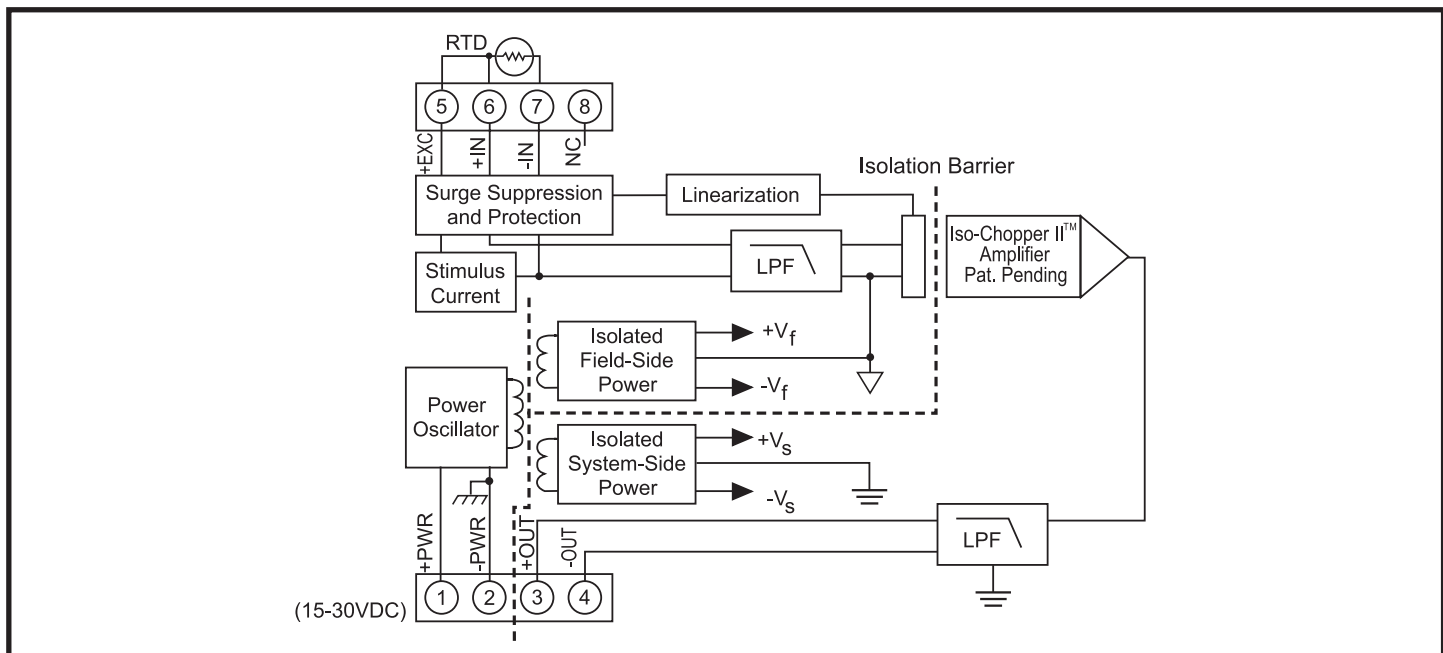

Figure 1: DSCA34 Block Diagram

Specifications Typical at $T_A = +25^\circ\text{C}$ and +24V supply voltage

Module	DSCA34
Input Range Limits	-200°C to +850°C (100Ω Pt) -80°C to +320°C (120Ω Ni)
Input Protection Continuous Transient	240Vrms max ANSI/IEEE C37.90.1
Sensor Excitation Current Lead Resistance Effect	≈ 250μA ±0.02°C/Ω
Output Range Load Resistance (I_{OUT}) Current Limit Output Protection Short to Ground Transient	See Ordering Information 600Ω max 8mA (V_{OUT}), 30mA (I_{OUT}) Continuous ANSI/IEEE C37.90.1
CMV, Input to Output, Input to Power Continuous Transient	1500Vrms max ANSI/IEEE C37.90.1
CMV, Output to Power Continuous CMR (50Hz or 60Hz)	50VDC max 160dB
Accuracy Conformity	See Ordering Information ±0.025% (100Ω Pt) ±0.07% (120Ω Ni)
Adjustability Stability Input Offset Output Offset Gain	±3% zero and span ±1μV/°C ±6ppm/°C (V_{OUT}), ±20ppm/°C (I_{OUT}) ±60ppm/°C
Output Noise, 100kHz Bandwidth	250μVrms (V_{OUT}), 1μArms (I_{OUT})
Bandwidth, -3dB NMR Response Time, 90% Span Open Input Response	3Hz 85dB at 60Hz, 80dB at 50Hz 165ms
'+' Lead '-' Lead 'x' Lead	Upscale Non-deterministic Downscale
Power Supply Voltage Current Sensitivity Protection Reverse Polarity Transient	15 to 30VDC 25mA (V_{OUT}), 55mA (I_{OUT}) ±0.0001%/° Continuous ANSI/IEEE C37.90.1
Environmental Operating Temperature Range Storage Temperature Range Relative Humidity Emissions EN61000-6-4 Radiated, Conducted Immunity EN61000-6-2 RF ESD, EFT	-40°C to +80°C -40°C to +80°C 0 to 95% Noncondensing ISM, Group 1 Class A ISM, Group 1 Performance A ±0.5% Span Error Performance B
Mechanical Dimensions (h)(w)(d) Mounting	2.95" x 0.89" x 4.13" (75mm x 22.5mm x 105mm) DIN EN 50022 -35x7.5 or -35x15 rail

NOTES:

(1) Includes conformity, hysteresis and repeatability.

Installation Notes:

- 1.) This Equipment is Suitable for Use in Class I, Division 2, Groups A, B, C, D, or Non-Hazardous Locations Only.
- 2.) Warning - Explosion Hazard - Substitution of Components May Impair Suitability for Class I, Division 2.
- 3.) Warning - Explosion Hazard - Do Not Disconnect Equipment Unless Power Has Been Switched Off or The Area is Known to be Non-Hazardous.

Ordering Information

Model	Input Range	Output Range [†]	Accuracy ¹	
100Ω Pt ** DSCA34-01	-100°C to +100°C (-148°F to +212°F)	2, 3, 4	±0.08%	±0.16°C
DSCA34-02	0°C to +100°C (+32°F to +212°F)	2, 3, 4	±0.10%	±0.10°C
DSCA34-03	0°C to +200°C (+32°F to +392°F)	2, 3, 4	±0.08%	±0.16°C
DSCA34-04	0°C to +600°C (+32°F to +1112°F)	2, 3, 4	±0.05%	±0.30°C
DSCA34-05	-50°C to +350°C (-58°F to +662°F)	2, 3, 4	±0.05%	±0.20°C
120Ω Ni ** DSCA34N-01	0°C to +300°C (+32°F to +572°F)	2, 3, 4	±0.15%	±0.45°C

†Output Ranges Available

Output Range	Part No. Suffix	Example
1. -10V to +10V	NONE	NA
2. 0V to +10V	NONE	DSCA34-01
3. 4 to 20mA	C	DSCA34-01C
4. 0 to 20mA	E	DSCA34-01E

****RTD Standards**

Type	Alpha Coefficient	DIN	JIS	IEC
100Ω Pt	0.00385	DIN 43760	JIS C 1604-1989	IEC 751
120Ω Ni	0.00672			

DSCA