

SG-3383 User's Manual

3-channel DC Current Signal Splitter Module

Rev1.20

Introduction

The SG-3383 DC current signal splitters accept one 4 to 20 mA current input and provide three optically isolated 4 to 20 mA current outputs that are linearly related to the 4 to 20 mA current input. This provides an economical solution when one signal must be sent to three different devices. Typical applications include isolation, output splitting, output device separation and redundancy (i.e. to prevent failure of the entire loop if one device fails), or a combination of these. The input signal is filtered, amplified, split, and then passed through an opto-coupler to the output stages. Full 3-way isolation (input, output, power) , 4 kV EFT Protection for Power Line and 8 kV ESD Protection make this module useful for ground loop elimination, common mode signal rejection, and noise pickup reduction.

The SG-3383 includes an LED display that can be used to indicate whether the module is functioning correctly, and also includes VRs (Zero, Span) that can be used to calibrate the output range accuracy. The input bandwidth of the SG-3383 is typically 2.5 kHz.

Specifications

Current Input:

- ◆ Unipolar: +4 ~ +20 mA
- ◆ Input Impedance: 125 Ω
- ◆ Input Bandwidth: 2.5 kHz (typical)

Current Output:

- ◆ Current: +4 ~ +20 mA
- ◆ Current Output Wring: Source
- ◆ Accuracy: $\pm 0.1\%$ of FSR (typical)
- ◆ Current Load Resistor: 0 ~ 500 Ω

General:

- ◆ 3-way Isolation: 3000 V_{DC}
- ◆ Operation Temperature Range: -25°C to +75°C
- ◆ Storage Temperature Range: -30°C to +85°C
- ◆ Operation Bandwidth: 2.5 kHz

Supply Voltage:

- ◆ Input Range: +10 ~ +30 V_{DC}
@24 V_{DC} (Typical)
- ◆ Consumption: 2.5 W

For more details, please visit at

http://www.icpdas.com/root/product/solutions/signal_conditioning_modules/sg-3000/sg-3383.html

Pin Assignments/Wiring

- ◆The terminal wiring for the SG-3383 is shown below
- ◆Power input, current input and current output can be connected
- ◆The SG-3383 uses a power input range of +10~ +30V_{DC}

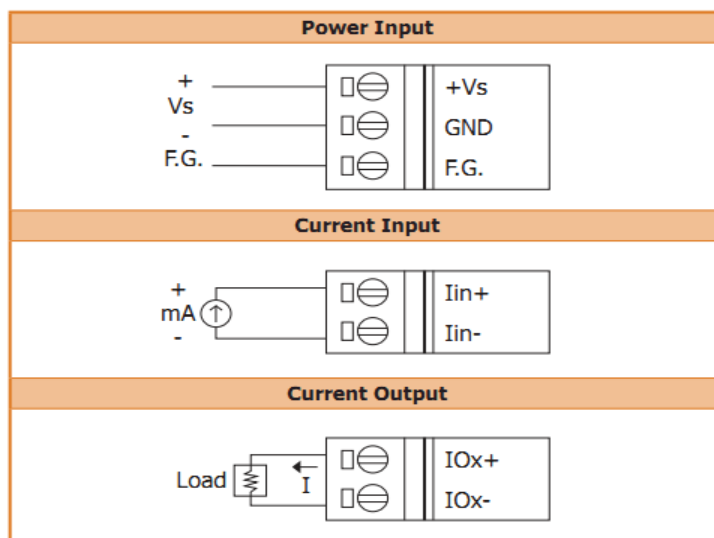
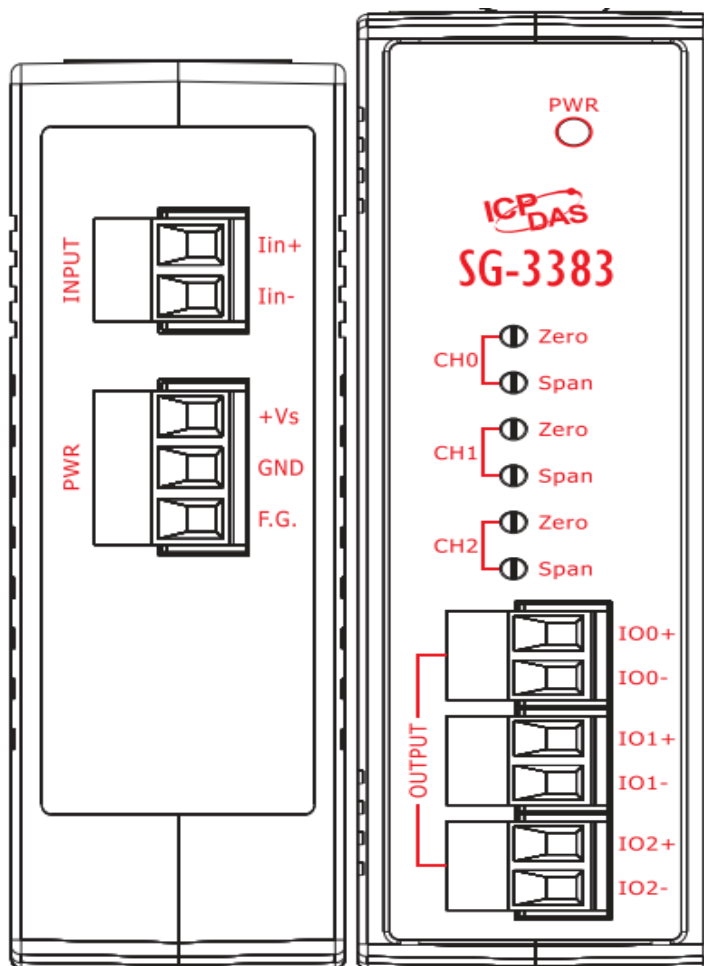

Configuration

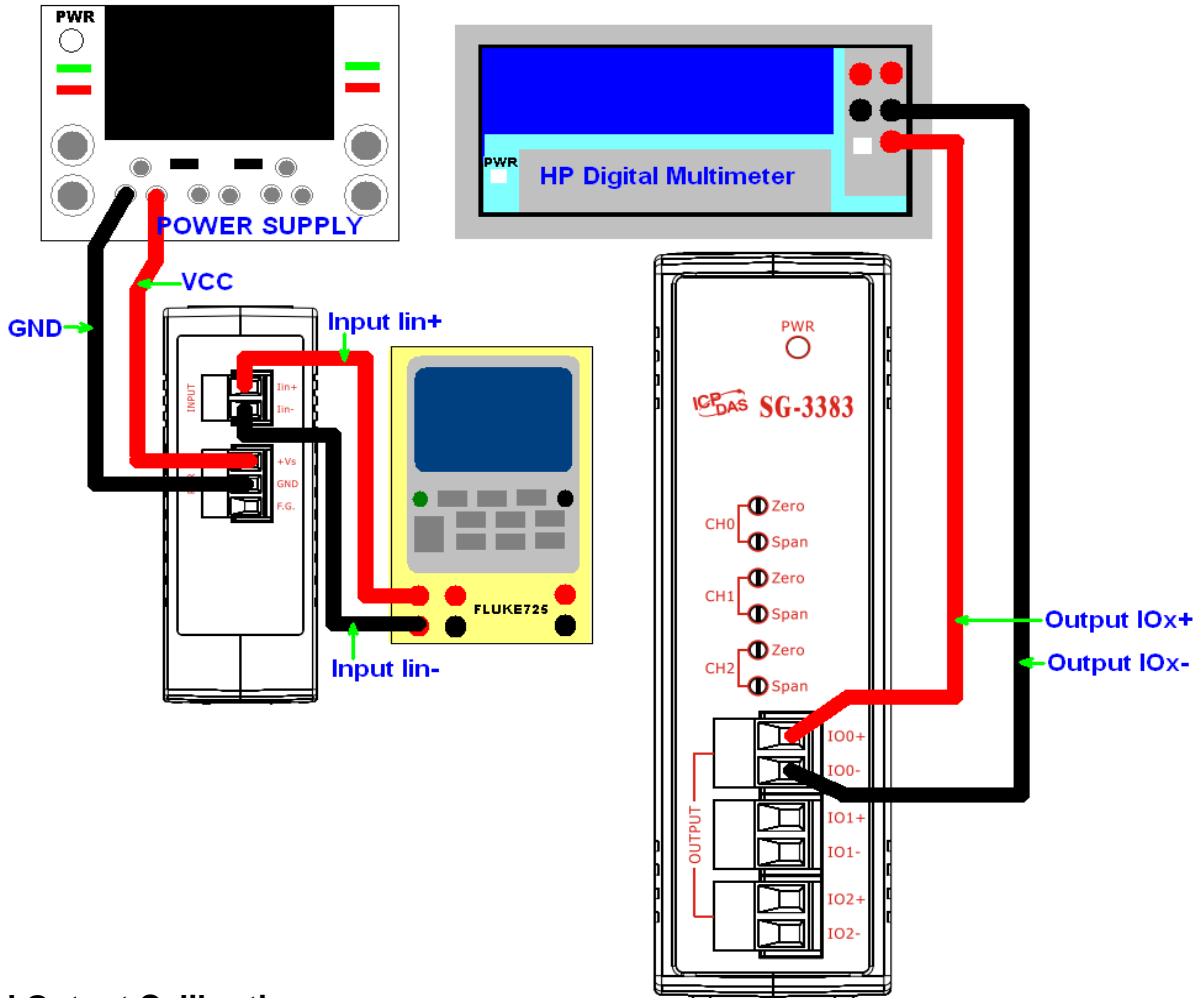

Input and Output Calibration

** Define the following variables for calibration use **

- Source current input +4 mA = output reading+4 mA
- Source current input +20 mA = output reading+20 mA

- ◆1. Connect a +4 mA source current to the INPUT pin the SG-3383, and read the output for the 4 mA signal on the multimeter.
- ◆2. Connect a +20 mA source current to the INPUT pin the SG-3383, and read the output for the 20 mA signal on the multimeter.
- ◆3. Adjust the ZERO variable resistor the SG-3383 and repeat Steps1 and 2 until the following condition are met.

(Source current for the +4 mA input signal = output value read for the +4 mA signal)--eq1

- ◆4. Adjust the SPAN variable resistor the SG-3383 and repeat Steps1 and 2 until the following conditions are met.

(Source current for the +4 mA input signal = output value read for the +4 mA signal)---eq2
 (Source current for the +20 mA input signal = output value read for the +20 mA signal)---eq3

- ◆5. If the readings fail to meet the conditions described in eq2 and eq3, repeat Steps 3 and 4 for channels0, 1 and 2 until the conditions specified in Step 4 are successfully met.

Block Diagram

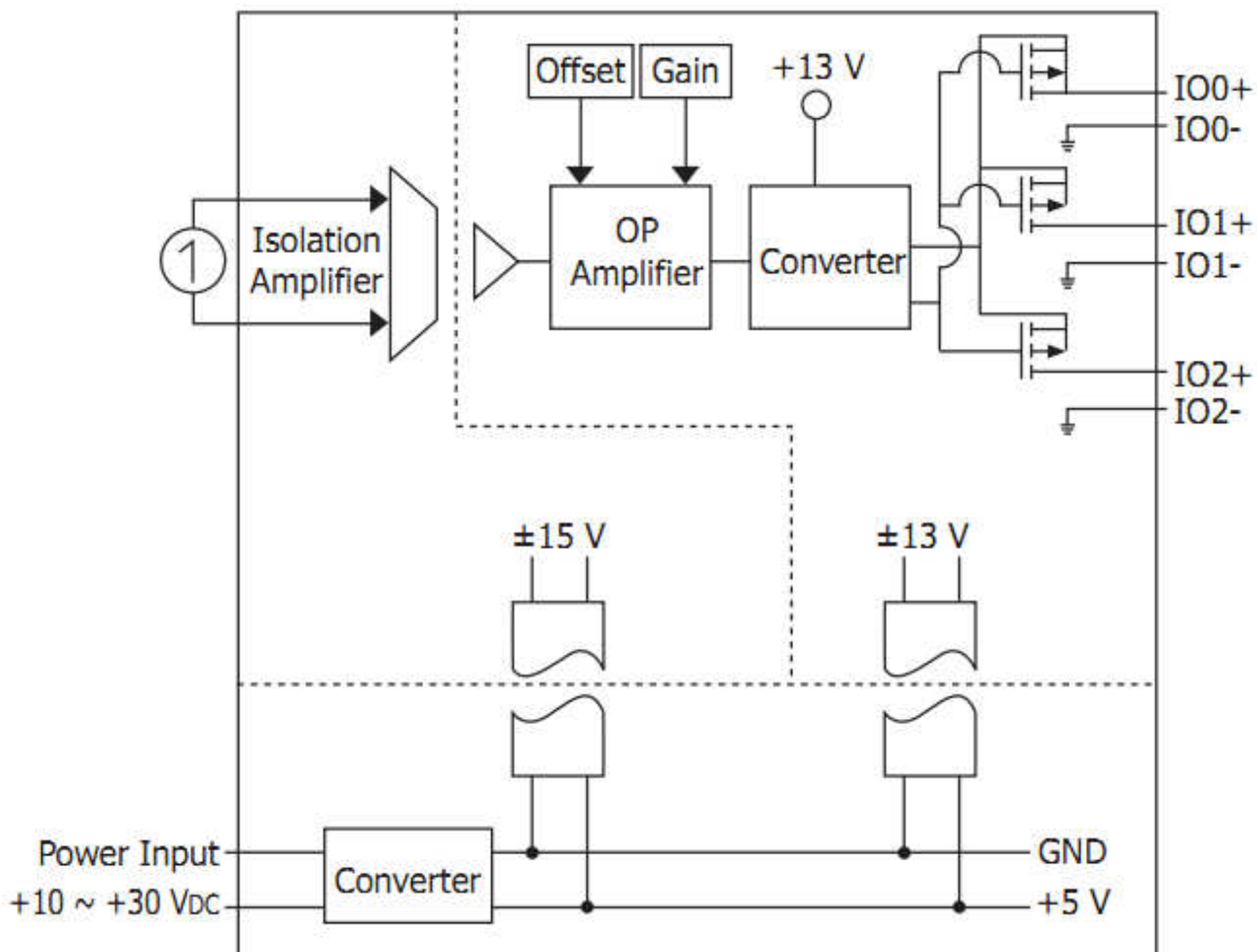

Dimensions (Units: mm)

