



ITP-G802SM

EN50155 IP67 Managed 8x 10/100/1000Base-T + 2x 100/1000Base-X SFP+ Ethernet Switch

ITP-G800M

EN50155 IP67 Managed 8x 10/100/1000Base-T Ethernet Switch

ITP-G802SM series are managed industrial grade Gigabit switches with 8x 10/100/1000Base-T ports and/or 2 SFP Gigabit/Fast Ethernet ports that provide stable and reliable Ethernet transmission. The ITP-G802SM series provide L2 management functions supported include STP/RSTP/MSTP/ITU-T G.8032 Ring and multiple u-Ring for redundant cabling, layer 2 Ethernet IGMP, VLAN, QoS, Security, IPv6, bandwidth control, port mirroring, cable diagnostic and Green Ethernet.

Housed in rugged DIN rail or wall mountable enclosures, these switches are designed for the harshest environments. Especially, ITP-G802SM series switches use M12 connectors to ensure tight, robust connections and to guarantee reliable and anti environmental disturbances operation, such as vibration and shock. ITP-G802SM series are compliant with EN 50155, covering power input voltage, surge, EFT, ESD, vibration, shock, thus making the switches suitable for industrial applications, such as vehicle, rolling stock, ship, vessel.

ITP-G802SM series are IP67 rated to protect against dust and water submersion. They are particularly used in environments with extreme temperature, high humidity, oil, dust and in outdoor environments requiring water-proof applications such as IP surveillance, city security. ITP-G802SM series can also work with CTC Management platform SmartView to provide convenient, real-time and centralized network management.

Features

- 8x 10/100/1000Base-T M12 and 2x 100/1000Base-X SFP Fiber (Total 10 Port) (ITP-G802SM)
- 8x 10/100/1000Base-T M12 (Total 8 port) (ITP-G800M)
- M12 and M23 connector against vibration and shock
- IP67 water proof design against dust and water (Figure 3)
- Redundant and wide input range voltage, Low voltage (12/24/48VDC) and High Voltage (110/220VDC or 110/220VAC)
- UL60950-1, CE, FCC, Rail Traffic EN50155, EN50121-4 certified
- Industrial Grade EMS, EMI, EN61000-6-2, EN61000-6-4 certified
- Cable diagnostic, Measuring cable OK or broken point distance
- Supports Green Ethernet IEEE802.3az EEE (Energy Efficient Ethernet) management to optimize the power consumption
- STP, RSTP, MSTP, ITU-T G.8032 Ethernet Protection Ring (EPR) for redundant cabling
- Provide up to 5 instances that each supports u-Ring, u-Chain or Sub-Ring type for flexible uses (Figure 5)
- u-Ring for Redundant Cabling, recovery time < 10ms in 250 maximum devices
- DHCP Server/Client/Relay/Snooping/Snooping option 82/Relay option 82
- QoS, Traffic classification QoS, CoS, bandwidth control for Ingress and Egress, Storm Control, DiffServ
- IEEE802.1q VLAN, MAC based VLAN, IP subnet based VLAN, Protocol based VLAN, VLAN translation, GVRP, MVR
- Dynamic IEEE 802.3ad LACP Link Aggregation, Static Link Aggregation
- IGMP snooping V1/V2/V3, IGMP Filtering/ Throttling, IGMP query, IGMP proxy reporting, MLD snooping V1/V2
- Security : Port based and MAC based IEEE802.1X, RADIUS, ACL, TACACS+, HTTP/HTTPS, SSL/SSH v2
- Software upgrade via TFTP and HTTP, redundant firmware to avoid in case of upgrade failure
- Support IEEE1588 PTP V2 for precise time synchronization to operate in Ordinary-Boundary, Peer to Peer Transparent Clock, End to End Transparent Clock, Master, Slave mode by each port
- RMON, MIB II, Port mirroring, Event syslog, DNS, NTP IEEE802.1ab LLDP
- Support 5 operating mode in each port: Ordinary-Boundary, Peer to Peer Transparent Clock, End to End Transparent Clock, Master, Slave
- Supports IPv6 Telnet server /ICMP v6
- CLI, Web based management, SNMP v1/v2c/v3, Telnet server for management
- Provides SmartConfig for quick and easy mass configuration
- Supports SmartView for Centralized Management

Specifications

Standard	IEEE 802.3	10Base-T 10Mbit/s Ethernet
	IEEE 802.3u	100Base-TX, 100Base-FX, Fast Ethernet
	IEEE 802.3ab	1000Base-T Gbit/s Ethernet over twisted pair
	IEEE 802.3z	1000Base-X Gbit/s Ethernet over Fiber-Optic
	IEEE 802.1d	STP (Spanning Tree Protocol)
	IEEE 802.1w	RSTP (Rapid Spanning Tree Protocol)
	IEEE 802.1s	MSTP (Multiple Spanning Tree Protocol)
	ITU-T G.8032 / Y.1344	ERPS (Ethernet Ring Protection Switching)
	IEEE 802.1Q	Virtual LANs (VLAN)
	IEEE 802.1X	Port based and MAC based Network Access Control, Authentication
Standard	IEEE 802.3ad	Link aggregation for parallel links with LACP(Link Aggregation Control Protocol)
	IEEE 802.3x	Flow control for Full Duplex
	IEEE 802.1ad	Stacked VLANs, Q-in-Q
	IEEE 802.1p	LAN Layer 2 QoS/CoS Protocol for Traffic Prioritization
VLAN ID	IEEE 802.1ab	Link Layer Discovery Protocol (LLDP)
	IEEE 802.3az	EEE (Energy Efficient Ethernet)
	4094	IEEE802.1Q VLAN VID
Switch Architecture	Back-plane (Switching Fabric): 20Gbps (ITP-G802SM) 16Gbps (ITP-G800M) (Full wire-speed)	
	Data Processing Store and Forward	

Flow Control	IEEE 802.3x for full duplex mode Back pressure for half duplex mode
Network Connector	8x M12 (8-Pin, Female, A-Code) 10/100/1000Base-T auto negotiation speed, Auto MDI/MDI-X function, Full/Half duplex Water proof Fiber Cable Gland support for 2 X 100/1000 Base-X SFP slot, with DDMI (for ITP-G802SM)
Console	RS-232 (5-pin A-Code M12 male)
Network Cable	UTP/STP above Cat. 5e cable EIA/TIA-568 100-ohm (100m)
Protocols	CSMA/CD
Reverse Polarity Protection	Present
Overload Current Protection	Present
CPU Watch Dog	Present
LED	Per unit: Power 1 (Green), Power 2 (Green), Fault (Amber), CPU Act (Green), Ring Master (Yellow)
	Per UTP port: 10/100 Link/Active (Green) 1000 Link/Active (Amber)
Jumbo Frame	SFP Fiber Per port: Link/Active (Green) 9.6KB
MAC Address Table	8K
Memory Buffer	256K Bytes for packet buffer

Power Supply	Provide 1x M23 (5-Pin, male) for redundant dual input, optional Low (L) or High (H) voltage. Low voltage (L): 12/24/48V (8.4~60VDC) High voltage (H): 110/220VDC (88~300VDC), or 110/220VAC (88~264VAC)				
Power Consumption		ITP-G802SM-LL	ITP-G802SM-HL	ITP-G800M-LL	TP-G800M-HL
	12VDC	8.5	9.9	7.6W	9.4W
	24VDC	9.2W	10.3	8.9W	9.6W
	48VDC	11	11.6	10.6W	11.1W
	110 VAC/ VDC		9.9W		8.6W
	220 VAC/ VDC		9.9W		8.6W
Warning Message	System Syslog, SMTP/ e-mail event message, alarm relay				
Alarm Relay Contact	5-pin A-code M12 male Relay outputs with current carrying capacity of 1 A @24VDC				
Operating Temperature	-10 ~ 60°C (ITP-G802SM , ITP-G800M) -40 ~ 75°C (ITP-G802SM-E , ITP-G800M-E)				
Operating Humidity	5% to 95% (Non-condensing)				
Storage Temperature	-40 ~ 85°C				
Housing	Rugged Metal, Fanless , IP67 water proof protection (Figure 3)				
Dimensions	70x240x168mm (D x W x H)				
Weight	2.645kg (ITP-G802SM-LL) 2.82kg (ITP-G802SM-HL) 2.53kg (ITP-G800M-LL) 2.705g (ITP-G800M-HL)				
Installation Mounting	Wall mounting, or DIN Rail mounting (Optional)				

MTBF	215,292 Hours (ITP-G802SM-LL) 188,971 Hours (ITP-G802SM-HL) 233,294 Hours (ITP-G800M-LL) 202,701 Hours (ITP-G800M-HL) (MIL-HDBK-217)
Warranty	5 years
Certification	
EMC	CE
EMI (Electromagnetic Interference)	FCC Part 15 Subpart B Class A, CE EN55022 Class A
Railway Traffic	EN50155, EN50121-4
Immunity for Heavy Industrial Environment	EN61000-6-2
Emission for Heavy Industrial Environment	EN61000-6-4
EMS (Electromagnetic Susceptibility)	EN61000-4-2 (ESD) Level 3, Criteria B EN61000-4-3 (RS) Level 3, Criteria A
Protection Level	EN61000-4-4 (Burst) Level 3, Criteria A EN61000-4-5 (Surge) Level 3, Criteria B EN61000-4-6 (CS) Level 3, Criteria A EN61000-4-8 (PFMF, Magnetic Field) Field Strength: 300A/m, Criteria A
Safety	UL60950-1
Shock	IEC-61373
Freefall	IEC 60068-2-32
Vibration	IEC-61373

Software Specifications

Topology	
VLAN	IEEE 802.1q VLAN, up to 4094 802.1Q VLAN VID IEEE 802.1q VLAN, up to 4094 Groups IEEE 802.1ad Q-in-Q MAC-based VLAN, up to 256 entries IP Subnet-based VLAN, up to 128 entries Protocol-based VLAN(Ethernet, SNAP, LLC), up to 128 entries VLAN Translation, up to 256 entries GVRP (GARP VLAN Registration Protocol) MVR (Multicast VLAN Registration)
Link Aggregation (Port Trunk)	Static (Hash with SA, DA, IP, TCP/UDP port), up to 5 trunk group Dynamic (IEEE 802.3ad LACP), up to 5 trunk group
Spanning Tree	IEEE802.1d STP, IEEE802.1w RSTP, IEEE802.1s MSTP
Multiple u-Ring	up to 5 instances that each supports u-Ring, u-Chain or Sub-Ring type for flexible uses, and maximum up to 5 Rings. Recovery time <10ms The maximum number of devices allowed in a Ring supported ring is 250.
Loop Protection	Present
ITU-T G.8032 / Y.1344 ERPS (Ethernet Ring Protection)	Recovery time <50ms Single Ring, Sub-Ring, Multiple ring topology network
QoS Feature	
Class of Service	IEEE802.1p 8 active priorities queues for per port
Traffic Classification QoS	IEEE802.1p based CoS IP Precedence based CoS IP DSCP based CoS QCL(QoS Control List): Frame Type, Source/Destination MAC, VLAN ID, PCP, DEI QCE(QoS Control Entry): Protocol, Source IP, IP Fragment, DSCP, TCP/UDP port number
Bandwidth Control for Ingress	Rate in steps :1 kbps / Mbps / fps / kfps Range : 100 kbps to 1Gbps / 1fps to 3300kfps Rate Unit : bit or frame
Bandwidth Control for Egress	Rate in steps : 1 kbps / Mbps Range : 100 kbps to 1Gbps Rate Unit : bit Per queue / Per port shaper
DiffServ (RF 2474) Remarkings	
Storm Control	for Unicast, Broadcast, Multicast
IP Multicasting Feature	
IGMP / MLD Snooping	IGMP Snooping v1, v2, v3 / MLD Snooping v1, v2 Port Filtering Profile, Throttling
IGMP / MLD Snooping	Fast Leave Maximum Multicast Group : up to 1022 entries Query / Static Router Port

Security Features	
IEEE 802.1X	Port-Based, MAC-Based
ACL	Number of rules : up to 256 entries for L2 / L3 / L4
RADIUS authentication & accounting	
TACACS+ authentication & accounting, TACACS+ 3.0	
HTTPS, HTTP	
SSL / SSH v2	
User Name Password Authentication	Local Authentication
Remote Authentication	Remote Authentication (via RADIUS / TACACS+)
Management Interface Access Filtering	Web, Telnet / SSH , CLI RS-232 console
Management Features	
CLI	Cisco® like CLI
Web Based Management	
Telnet	Server
SNMP	V1, V2c, V3
SW & Configuration Upgrade	TFTP, HTTP Redundant firmware in case of upgrade failure
RMON	RMON I (1, 2, 3, 9 group), RMON II
MIB II	RFC 1213
UPnP	
DHCP	Server, Client, Relay, Snooping Snooping option 82, Relay option 82
IP Source Guard	
Port Mirroring	
Event Syslog	Syslog server (RFC3164) (Support 1 server)
Warning Message	System syslog, e-mail, alarm relay
DNS	Client, Proxy
IEEE1588 PTP V2	Support 5 operating mode in each port : Ordinary-Boundary, Peer to Peer Transparent Clock, End to End Transparent Clock, Master, Slave
NTP	
LLDP (IEEE 802.1ab)	Link Layer Discovery Protocol LLDP-MED
IPv6 Features	
IPv6 Management	Telnet Server/ICMP v6
SNMP over IPv6	
HTTP over IPv6	
SSH over IPv6	
IPv6 Telnet Support	

IPv6 NTP Support	Support
IPv6 TFTP Support	
IPv6 QoS	
IPv6 ACL	Number of rules: up to 256 entries L2 / L3 / L4

Others Features	
Green Ethernet	Supports IEEE802.3az EEE (Energy Efficient Ethernet) Management to optimize the power consumption Determine the cable length and lowering the power for ports with short cables
Green Ethernet	Lower the power for a port when there is no link LED Power Management :Adjustment LEDs intensity
Cable Diagnostic	Measuring cable OK or broken point distance

Application

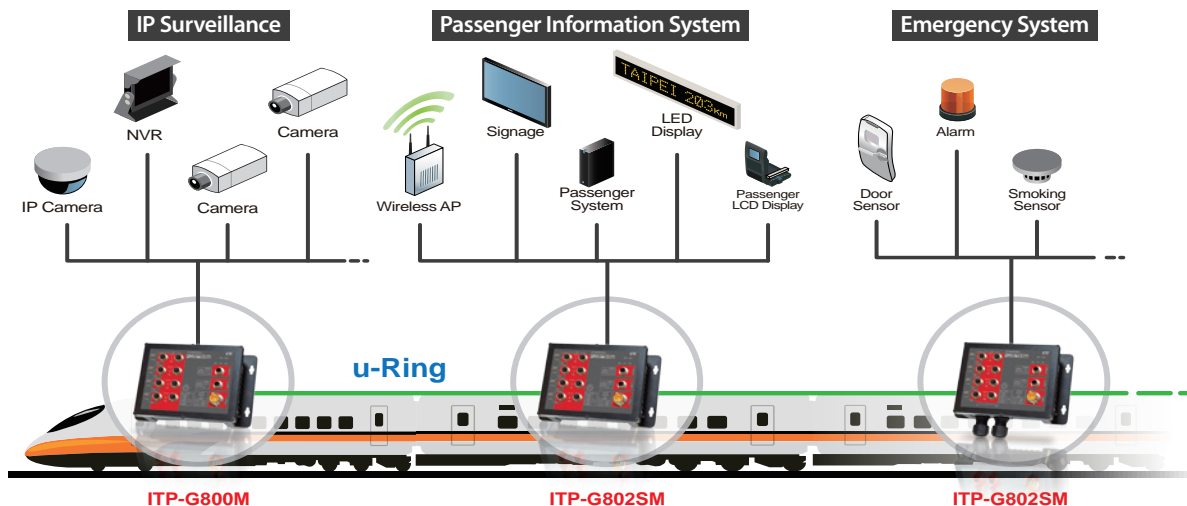

Figure 1 : ITP Series in Onboard Train Application



Figure 2 : ITP Series for Industrial Automation



Figure 3 : IP67 Waterproof

u-Ring Configuration Auto-refresh Refresh

Delete	Instance	Type	Master	East		West	
				Port	Edge	Port	Edge
Delete	1	u-Ring	<input type="checkbox"/>	1		2	
Delete	2	u-Ring	<input type="checkbox"/>	4		3	
Delete	3	u-Ring	<input type="checkbox"/>	10 (Fiber2)		11 (Fiber3)	
Delete	4	Sub-Ring	<input type="checkbox"/>	6			
Delete	5	u-Chain	<input type="checkbox"/>	5	<input type="checkbox"/>	9 (Fiber1)	<input type="checkbox"/>

Add New Instance

Save Reset

Figure 4 : An illustration of u-Ring instances configured in Web interface

Figure 5 : u-Ring Type

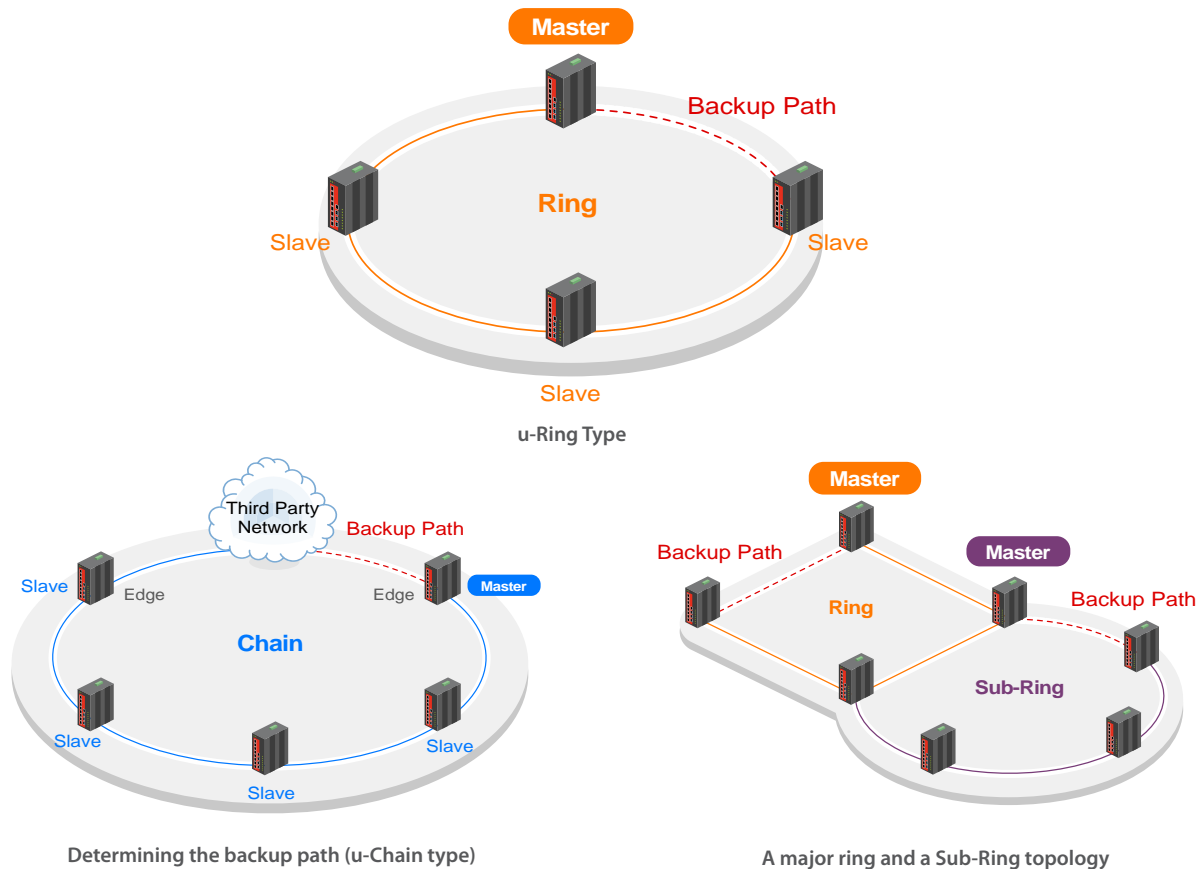
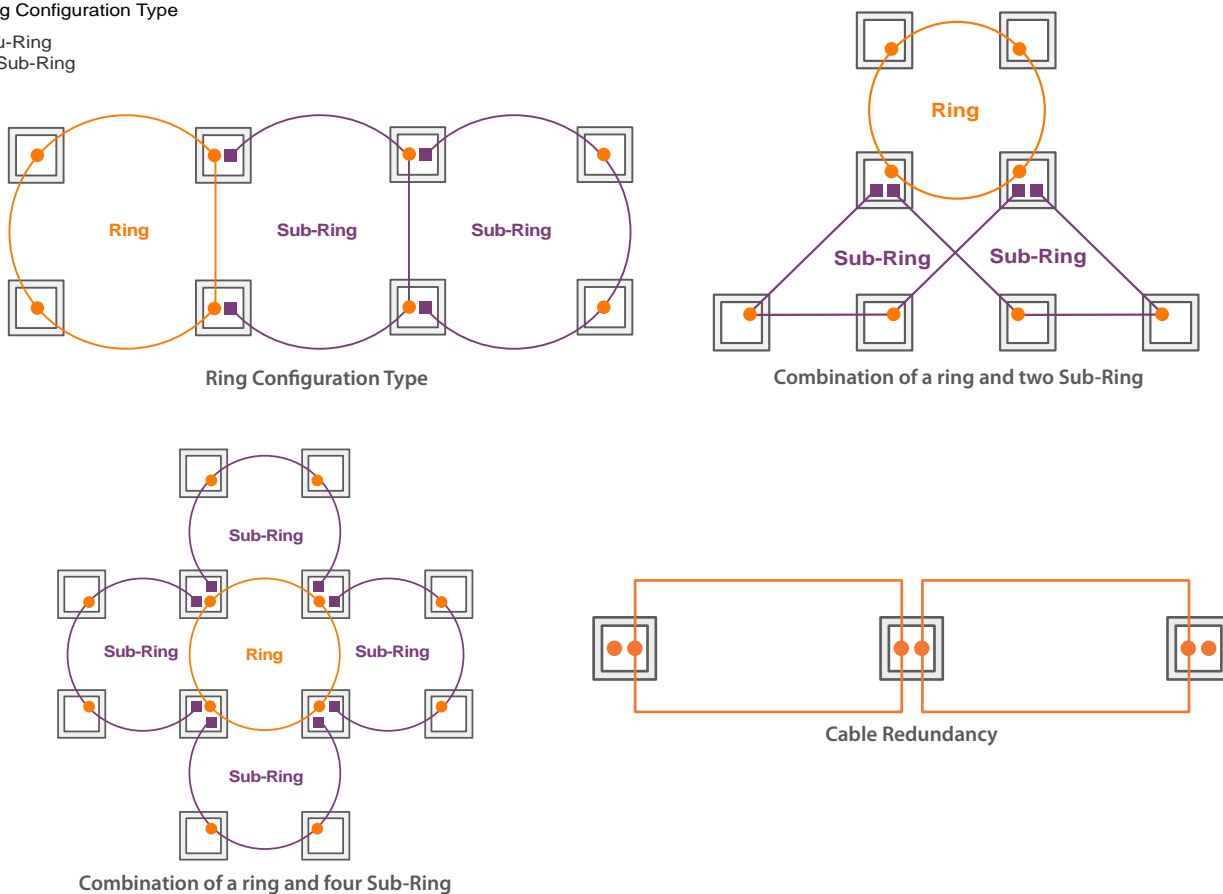

Figure 6 : Ring Configuration Example

Ring Configuration Type

- u-Ring
- Sub-Ring



Dimensions

ITP-G802SM

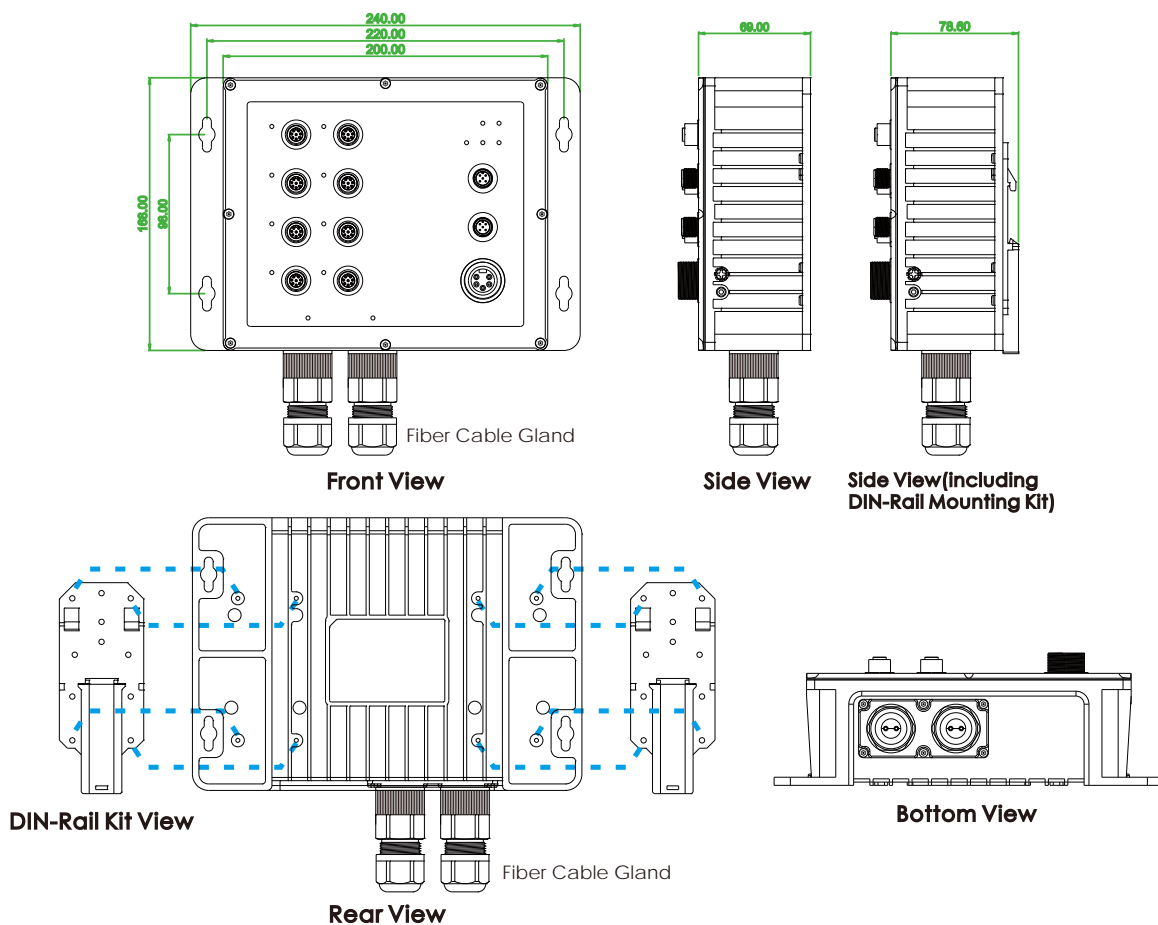

ITP-G800M

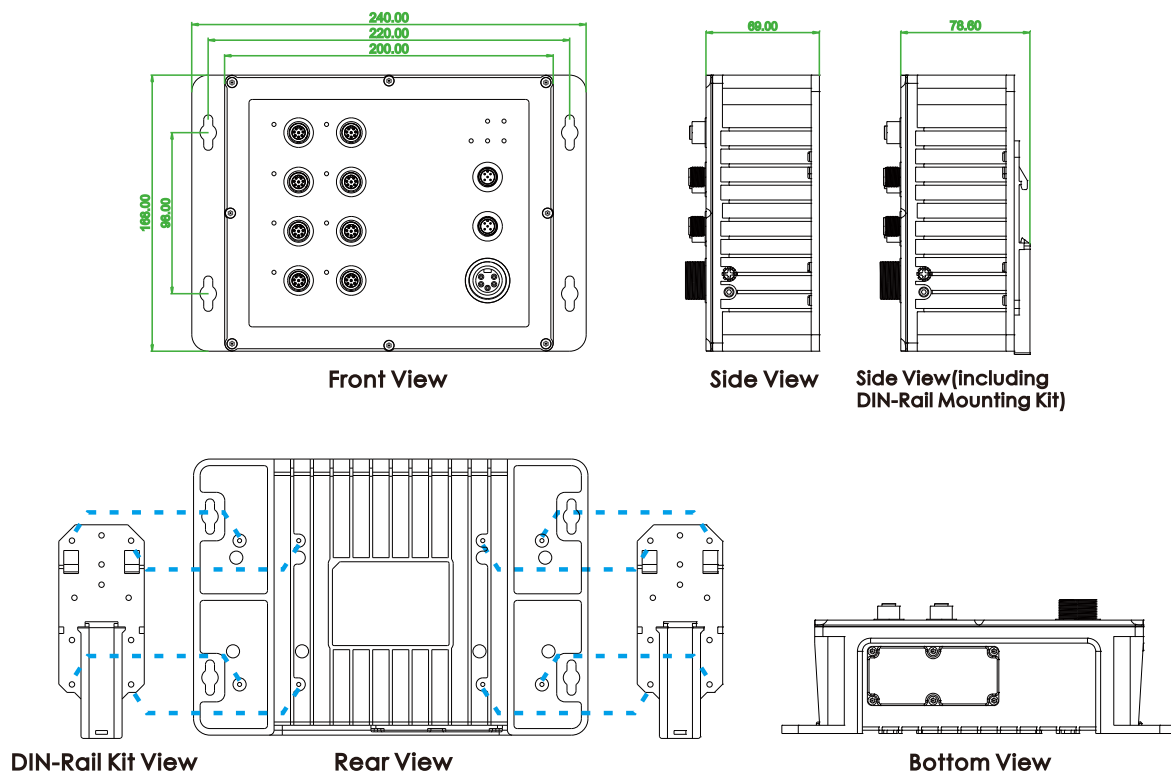

Ordering Information

Model Name	Managed	IP67	Total Port	UTP Port M12		Fiber Port		Power Supply		Certification				Shock Vibration IEC61373	Operating Temperature
				10/100/1000 Base-T	100/1000 Base-X	Low Volt 12/24/48VDC (8.4~60VDC)	High Volt 110/220 VDC 110/220 VAC	EN50155 EN50121-4	UL60950-1	EN61000-6-2 EN61000-6-4	CE FCC				
ITP-G802SM-LL	V	V	10	8	2 SFP	2	—	V	Plan	V	V	V	V	-10~60 C	
ITP-G802SM-HL	V	V	10	8	2 SFP	1	1	V	Plan	V	V	V	V	-10~60 C	
ITP-G802SM-ELL	V	V	10	8	2 SFP	2	—	V	Plan	V	V	V	V	-40~75 C	
ITP-G802SM-EHL	V	V	10	8	2 SFP	1	1	V	Plan	V	V	V	V	-40~75 C	
ITP-G800M-LL	V	V	8	8	—	2	—	V	Plan	V	V	V	V	-10~60 C	
ITP-G800M-HL	V	V	8	8	—	1	1	V	Plan	V	V	V	V	-10~60 C	
ITP-G800M-ELL	V	V	8	8	—	2	—	V	Plan	V	V	V	V	-40~75 C	
ITP-G800M-EHL	V	V	8	8	—	1	1	V	Plan	V	V	V	V	-40~75 C	

Model Naming Rule

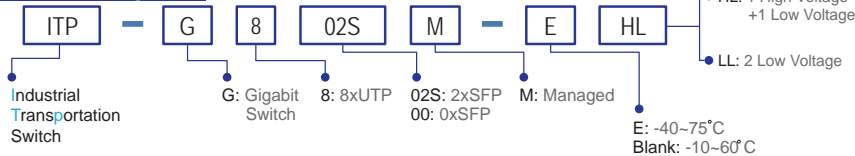

Optional Accessories

DR-4524	Industrial Power supply, Input 85 ~ 264VAC, Output 24VDC, 48W, -10 ~ +50°C
MDR-40-24	Industrial Power supply, Input 85 ~ 264VAC, Output 24VDC, 40W, -20 ~ +70°C
IND-DNK04	Din Rail Kit for Industrial, Wide : 52mm (130 X52mm / 4 Screws) (2pcs/set)
SmartView™	Network management platform with 50/100/200/500 device agents

Optional Accessories (SFP)

(The SFP series have been tested with the best operating performance on the series product.)
 (Please see CTC Industrial SFP for more detail and more item.)

ISFP-M7000-85-D(E)	Industrial SFP GbE, M/M, 500 meter, wave length 850nm, DDML, -10~70°C (-40~85°C)
ISFP-S7020-31-D(E)	Industrial SFP GbE, S/M, 20km, wave length 1310nm, DDML, -10~70°C (-40~85°C)
ISFP-T7100-00-D(E)	Industrial SFP GbE, UTP 100meter, DDML, -10~70°C (-40~85°C)

Package List

- ITP-G802SM or ITP-G800M device
- Protective caps for UTP port and Console, Alarm port
- Fiber Cable Gland for SFP port x2 set (for ITP-G802SM)
- Console cable (M12 to DB9)
- CD (SmartConfig, Manual)
- Quickly installation guide

SFP Naming Rule

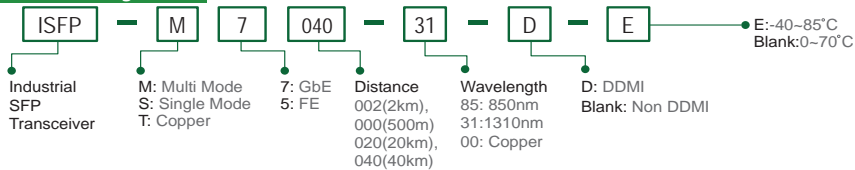

Optional M12 Cable

CAB-M12AM8-RJ45

M12 A-code Male (8-Pin) to RJ-45, AWG 24, IP67, 1 meter length



For GbE UTP

CAB-M12AF5-OPEN

M12 A-code Female (5-Pin) to open wire, AWG 22, IP67, 1 meter length



For Alarm

CAB-M23F5-OPEN

M23 Female (5-Pin) to open wire, (AWG 16), IP67, 1 meter length



For Power

Optional M12 Connector

M12A-M8

M12 A-code Male (8-Pin) connector, IP67



For GbE UTP

M12A-F5

M12 A-code Female (5-Pin) connector, IP67



For Alarm

Optional Din-Rail Kit

IND-DNK04

Din Rail Kit for Industrial, Wide: 52mm



(130 X52mm / 4 Screws) (2pcs/set)