

HPERC-IBR-HH

*Rugged System with 3rd Gen Intel® Core™ i7 Processor
and MIL-STD-38999 High Speed Connectors*

Features

- High speed eSATA, USB 3.0
- VITA 75 mount with passive cooling
- Intel® Core™ i7 dual or quad core Processor
- Soldered DDR3L 8GB, up to 16GB RAM
- Quad Gigabit Ethernet
- Available GPGPU on 16-lane 3rd Generation PCI Express
- Dual independent displays (HDMI/DVI/VGA)
- Simple user expansion and configuration
- Rugged temperature: -40°C to +70°C



Specifications

Core System

CPU	Intel® Core™ i7-3517UE 1.7GHz, dual-core Intel® Core™ i7-3612QE 2.1GHz, quad-core
Chipset	Intel® QM77 Express Chipset
GPGPU	MXM NVIDIA GT 745M with 2GB 128-bit GDDR5 (optional)
Memory	16GB DDR3L-1333 ECC 8GB soldered down, 8GB SODIMM
BIOS	AMI EFI
Expansion Busses	MXM (3 rd Generation PCIe x16) PCI/104 Express® Type 2 (PCIe Gen2) PCI Express Mini Card (PCIe Gen2)

Standard I/O

Video	2x DVI, 1x HDMI and 1x VGA (only 2 display outputs supported concurrently)
Audio	1x amplified stereo output 1x stereo input
LAN Chipset	4x Intel® I210 Ethernet controller
LAN Speed	10/100/1000 Mbps
eSATA	2x SATA 3Gb/s (non-powered)
USB	2x USB 3.0 4x USB 2.0
Serial	7x RS-232/422
GPIO	8x digital IO

Internal Storage

Removable SATA	2x 2.5" SLC/MLC SSD on SATA 6 Gb/s (up to 1 TB)
RAID	0/1 supports up to 12Gb/s
Removable	1x SDHC - SLC (up to 64 GB)

Security

TPM	Atmel AT97SC3204-U1A190
Secure Erase	Hardware input triggered Software triggered

Power

Input	10-36VDC
Performance	S-States S3, S4

Thermal

Internal Transfer	Passive conduction to body
Storage Temperature	-55°C to +85°C
Ambient Temperature	-40°C to +70°C at 1 atm air Heatsink (free air convection) VITA 75.21 mount

Environmental

Immersion	IEC 529 - IP-67
Humidity	95% at +60°C non-condensing
Shock	MIL-STD-810G - 516.6 Procedures I and V
Vibration	MIL-STD-810G - 514.6 Procedure I Categories 4, 9, 11, 21
EMI/EMC	MIL-STD-461F
Temperature	MIL-STD-810G - 501.5 Procedure II MIL-STD-810G - 502.5, Procedure 1 and 2

Mechanical

Form Factor	VITA-75 Finned Passive Convection
Dimension	304.8(L) x 150(W) x 101.95(H) mm (with mounting brackets)
Weight	3.91 kg
IO Connectors	MIL-DTL-38999 (uniquely-keyed)

Operating System

OS	Windows® 7 (64-bit) WES 7 (64-bit/32-bit) VxWorks 6.9.3.1 (Please contact ADLINK for other OS support)
----	---

Functional Diagram

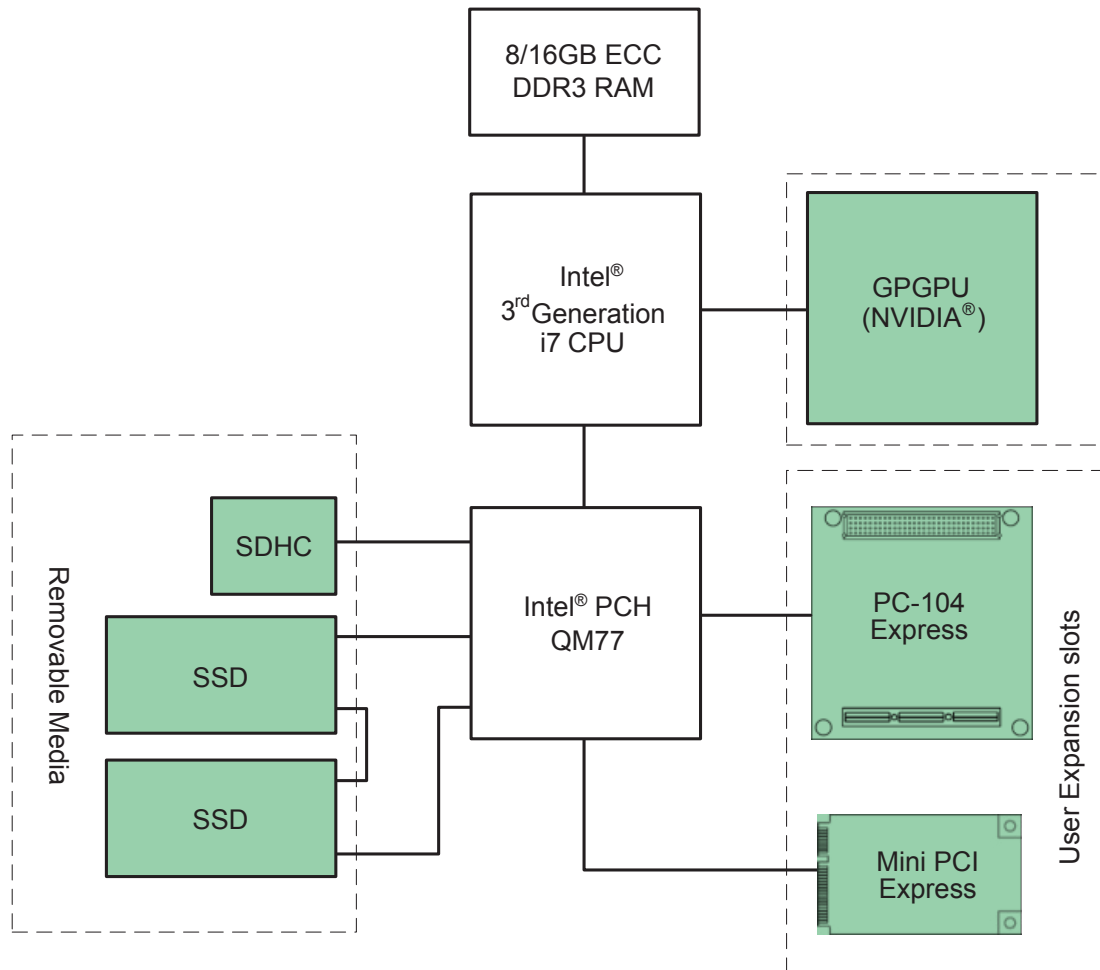

Ordering Information

Accessories

Model Number	Description/Configuration
HPERC Accessories	
HPERC-H-03	HPERC™ breakout cable kit including MERITEC MIL-STD Nkey & Akey and AC Adapter
M3N745M-JN-A	MXM NVIDIA GT 745M GPU card, with 2GB 128-bit GDDR5 memory (must be pre-assembled at ADLINK factory)

Configurations

Model Number	Description/Configuration
HPERC-IBR-HH	
HPERC-IBRHH-100XN	Finned-Convection, Intel® Core™ i7 3517UE, 16GB RAM
HPERC-IBRHH-B00XN	Finned-Convection, Intel® Core™ i7 3517UE, 8GB RAM
HPERC-IBRHH-300XN	Finned-Convection, Intel® Core™ i7 3612QE, 16GB RAM
HPERC-IBRHH-D00XN	Finned-Convection, Intel® Core™ i7 3612QE, 8GB RAM