

# GW-7663 User Manual

Version 1.00, Aug. 2015

## **Warranty**

---

All products manufactured by ICP DAS are under warranty regarding defective materials for a period of one year, beginning from the date of delivery to the original purchaser.

## **Warning**

---

ICP DAS assumes no liability for any damage resulting from the use of this product. ICP DAS reserves the right to change this manual at any time without notice. The information furnished by ICP DAS is believed to be accurate and reliable. However, no responsibility is assumed by ICP DAS for its use, not for any infringements of patents or other rights of third parties resulting from its use.

## **Copyright**

---

Copyright © 2015 by ICP DAS Co., Ltd. All rights are reserved.

## **Trademark**

---

The names used for identification only may be registered trademarks of their respective companies.

## **Contact US**

If you have any problem, please feel free to contact us.  
You can count on us for quick response.

Email: [service@icpdas.com](mailto:service@icpdas.com)

# Table of Contents

---

|   |           |
|---|-----------|
| <b>Table of Contents .....</b>                              | <b>3</b>  |
| <b>1. Introduction .....</b>                                | <b>5</b>  |
| 1.1. Features .....   | 6         |
| 1.2. Specification .....                                    | 7         |
| 1.3. Internal I/O Structure .....                           | 9         |
| 1.4. Overview .....   | 10        |
| 1.5. Dimensions.....  | 14        |
| <b>2. PROFINET .....</b>                                    | <b>15</b> |
| 2.1. Device classes of PROFINET IO.....                     | 15        |
| 2.2. Device Description.....                                | 16        |
| 2.3. Conformance Classes (CC).....                          | 17        |
| <b>3. Basic Application .....</b>                           | <b>18</b> |
| 3.1. Connect to Network, PC and PROFINET IO controller..... | 18        |
| 3.2. Network configuration.....                             | 19        |
| 3.3. GSD Import .....                                       | 27        |
| 3.4. Project Setup.....                                     | 29        |
| <b>4. Communication .....</b>                               | <b>37</b> |
| 4.1. Communication Sequence .....                           | 37        |
| 4.2. Module configuration .....                             | 41        |
| 4.3. PROFINET Input Data Area.....                          | 42        |
| 4.4. PROFINET Output Data Area.....                         | 43        |
| 4.5. Diagnostic Messages .....                              | 44        |
| 4.6. Data exchange example .....                            | 45        |

|  |           |
|--|-----------|
| 4.6.1. PLC receives DI status from Modbus slave.....                           | 46        |
| 4.6.2. PLC refreshes DO status to Modbus slave.....                            | 48        |
| <b>5. MiniOS7 Utility Tool.....</b>  | <b>50</b> |
| 5.1. Installing the MiniOS7 Utility .....                                      | 50        |
| 5.2. Using MiniOS7 Utility to get Ethernet settings and firmware version ..... | 51        |
| <b>6. PFN_Tool Utility.....</b>  | <b>53</b> |
| 6.1. Installing the PFN_Tool Utility .....                                     | 53        |
| 6.2. PFN_Tool Utility Functionalities .....                                    | 54        |
| 6.2.1. Module Search .....   | 54        |
| 6.2.2. Module Basic Configuration.....   | 55        |
| 6.2.3. Module Advanced Configuration.....                                      | 57        |
| <b>7. Troubleshooting .....</b>  | <b>66</b> |
| <b>8. Appendix .....</b>   | <b>67</b> |
| 8.1. Modbus Exception Code .....   | 67        |

# 1. Introduction

---

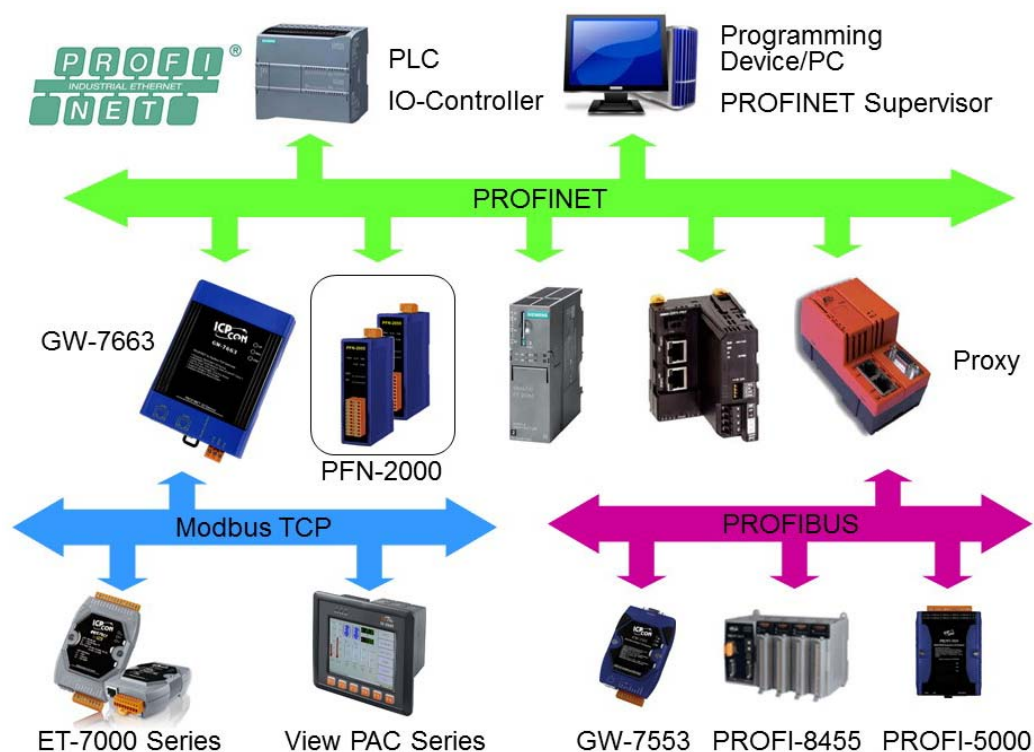

PROFINET is an open Industrial Ethernet standard developed by the PROFIBUS Organization (PI). Based on Ethernet versatility, PROFINET make vertical integration of field level with Enterprise level easily. PROFINET is automation in real time, so it can cover all requirements of the Automation Industry. PROFINET is fit for factory automation, process automation, safety applications and motion control applications, etc.

PROFINET contains 2 different solutions. They are PROFINET IO and PROFINET CBA (Component Based Automation). GW-7663 module are PROFINET IO device. The user can access and configure the modules easily by using the GSDML file in any PROFINET Engineering tool, and exchange process data quickly with the IO controller.

## 1.1. Features

- ◆ **Transfer protocol: PROFINET IO**
- ◆ **Supported Ethernet services: ICMP, IGMP, ARP, DHCP, TELNET, TFTP, SNMP, VLAN Priority Tagging**
- ◆ **Supported PROFINET services: RTC, RTA, CL-RPC, DCP, LLDP, I&M**
- ◆ **PROFINET Conformance Class B and RT Class 1**
- ◆ **Cyclic Time: 1ms (min)**
- ◆ **Generic GSDML File Provided**
- ◆ **Max. Input / Output data :512 / 512 bytes**
- ◆ **Support Modbus TCP format**
- ◆ **Support Modbus Master(Client) and Slave(Server) mode**
- ◆ **Maximum support 8 Modbus servers in Modbus Client mode**
- ◆ **Maximum support 4 Modbus clients in Modbus Server mode**
- ◆ **Integrated 2-Port Switch**
- ◆ **Automatic MDI / MDI-X Crossover for Plug-and-play**
- ◆ **Provide LED indicators**
- ◆ **Robust, fan less design**
- ◆ **4 kV Contact ESD protection for any terminal**
- ◆ **Wide range of power input (+10 ~ +30 VDC) and operating temperature (-25 ~ +75°C)**

## 1.2. Specification

| Hardware                |                     |
|-------------------------|---------------------|
| <b>CPU</b>              | 32-bit CPU Core     |
| <b>RAM/Flash/EEPROM</b> | 32 MB / 4 MB / 8 KB |
| <b>Watchdog</b>         | CPU built-in        |
| <b>ESD Protection</b>   | 4 kV class A        |

| PROFINET Interface         |                                  |
|----------------------------|----------------------------------|
| <b>Protocol</b>            | PROFINET IO Device               |
| <b>Conformance Classes</b> | Class B                          |
| <b>Services</b>            | RTC, RTA, CL-RPC, DCP, LLDP, I&M |
| <b>Cycle Time</b>          | 1 ms (min.)                      |

| Ethernet Interface |  |
|--------------------|--|
| <b>Controller</b>  | 10/100Base-TX Ethernet Controller (Auto-negotiating, Auto_MDIX)  |
| <b>Connector</b>   | RJ-45 x 2 (LED indicators) , Integrated 2-Port Switch            |
| <b>Services</b>    | ICMP, IGMP, ARP, DHCP, TELNET, TFTP, SNMP, VLAN Priority Tagging |

| LED Display      |                           |
|------------------|---------------------------|
| <b>Round LED</b> | AP LED, BOOT LED, ERR LED |

| Power Requirements       |  |
|--------------------------|--|
| <b>Power supply</b>      | Unregulated +10 ~ +30 VDC  |
| <b>Protection</b>        | Power reverse polarity protection, Over-voltage brown-out protection |
| <b>Power Consumption</b> | 3.4 W  |

| <b>Mechanical</b>   |                                    |
|---------------------|------------------------------------|
| <b>Dimensions</b>   | 42 mm x 76 mm x 110 mm (W x L x H) |
| <b>Installation</b> | DIN Rail or Wall mounting          |

| <b>Environment</b>           |                             |
|------------------------------|-----------------------------|
| <b>Operating Temperature</b> | -25 °C ~ +75 °C             |
| <b>Storage Temperature</b>   | -30 °C ~ +80 °C             |
| <b>Humidity</b>              | 10~ 90 % RH, non-condensing |



# 1.3. Internal I/O Structure

GW-7663 Internal I/O Structure

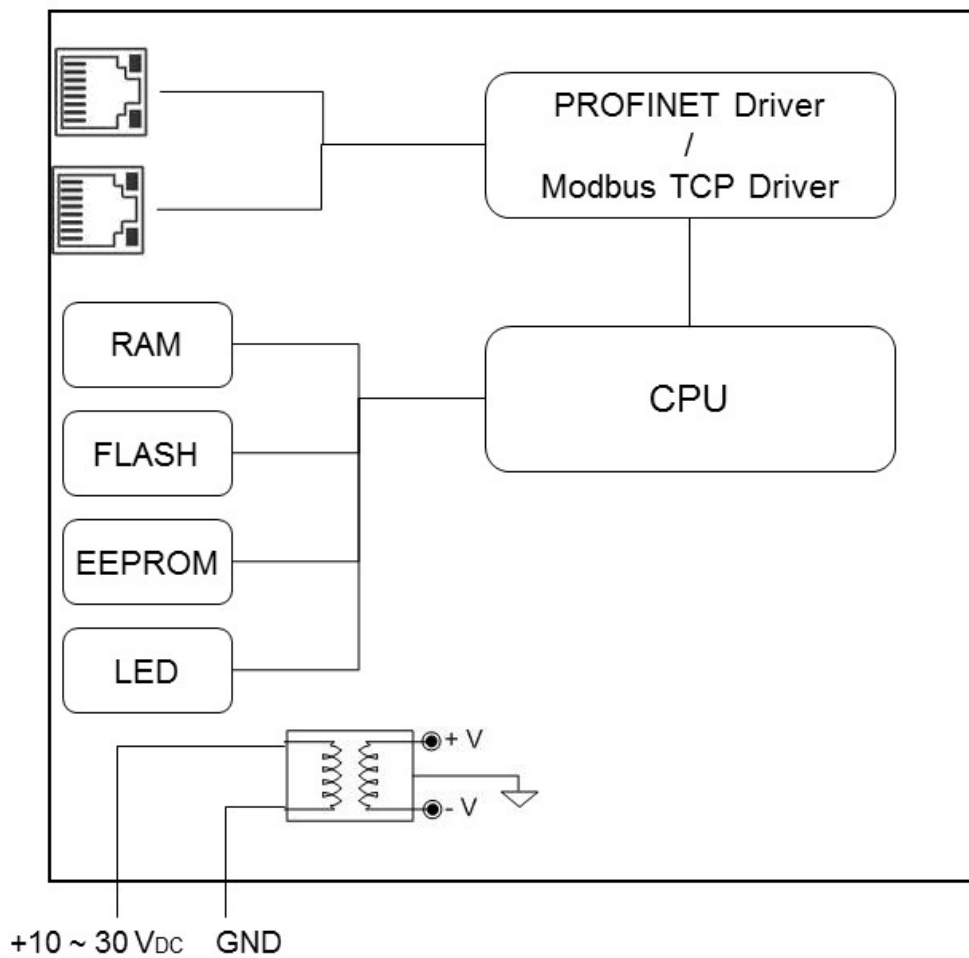

## 1.4. Overview

Here is a brief overview of the components and its descriptions for module status.

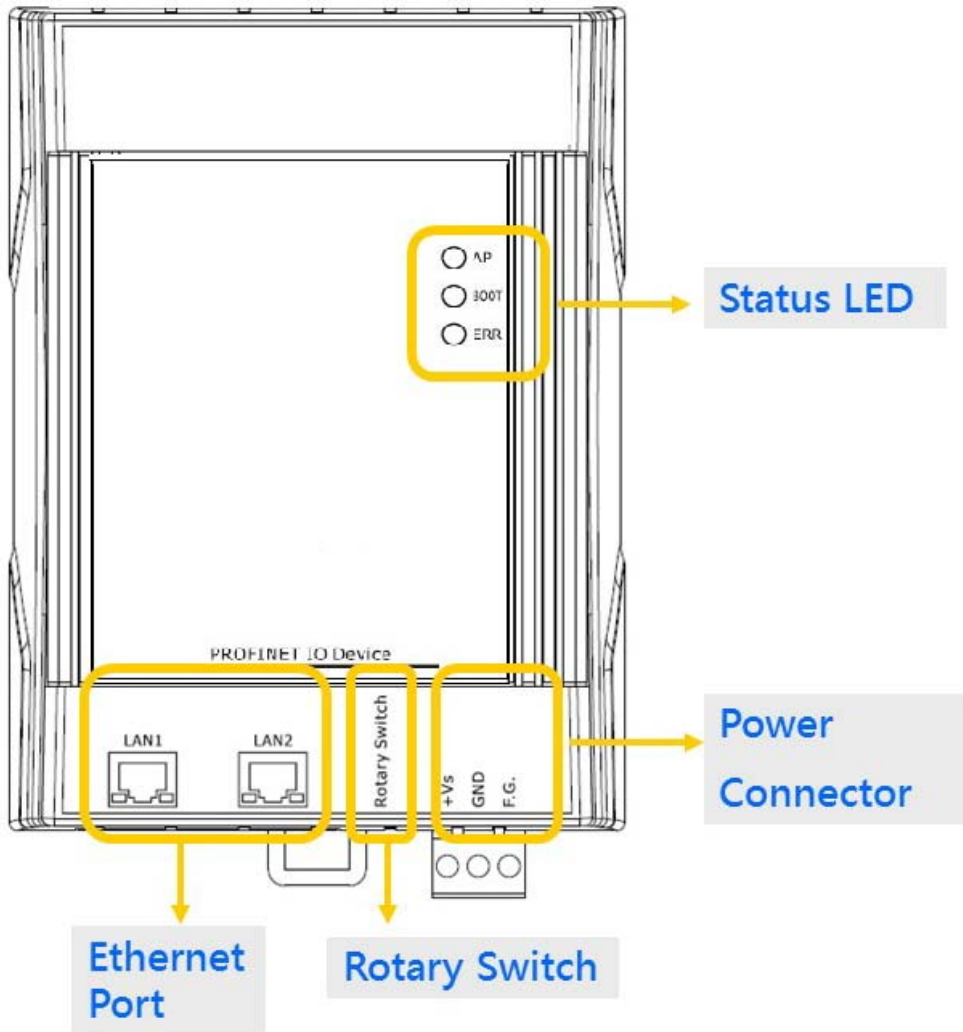

## ► Status LED Indicators

---

AP mode:

| AP  | BOOT         | ERR          | Description  |
|-----|--------------|--------------|--|
| OFF | OFF          | Flash (Slow) | waiting for PROFINET connection  |
| ON  | OFF          | OFF          | PROFINET connection is established.                                    |
| ON  | OFF          | Flash (Slow) | Device is at AP mode and the module received the incorrect parameters. |
| ON  | OFF          | Flash (Fast) | Error! GW-7663 has diagnostic message.                                 |
| ON  | Flash (Slow) | Flash (Slow) | Hardware authentication error!   |

Bootloader mode:

| AP           | BOOT | ERR | Description  |
|--------------|------|-----|--|
| ON           | ON   | OFF | waiting for Ethernet link                                  |
| OFF          | ON   | OFF | Ethernet link established, waiting for IP address acquired |
| Flash (Slow) | ON   | OFF | IP address acquired, waiting for telnet connection         |
| ON           | ON   | OFF | Telnet connection is established.                          |

Flash(Slow): about 500ms      Flash(Fast): about 100ms

## ► Ethernet Ports

---

An Ethernet port is an opening on GW-7663 network equipment that Ethernet cables plug into. Ethernet ports accept cables with RJ-45 connectors.

### Tips & Warnings

---



1. When users connect GW-7663 and switch, users should not connect LAN1 and LAN2 to switch at the same time, else it will lead to abnormal network.
2. When users connect network devices by daisy chain topology, users can connect these devices in series by LAN1 and LAN2.

---

## ► Rotary Switch

---

| Position | Mode            | Module configuration                  |
|----------|-----------------|---------------------------------------|
| 0        | AP mode         | Output: 32 bytes<br>Input: 32 bytes   |
| 1        | AP mode         | Output: 64 bytes<br>Input: 64 bytes   |
| 2        | AP mode         | Output: 128 bytes<br>Input: 128 bytes |
| 3        | AP mode         | Output: 256 bytes<br>Input: 256 bytes |
| 4        | AP mode         | Output: 384 bytes<br>Input: 384 bytes |
| 5        | AP mode         | Output: 512 bytes<br>Input: 512 bytes |
| 6~7      | AP mode         | Reserved                              |
| 8~F      | Bootloader mode | N/A                                   |

GW-7663 User Manual (Version 1.00, Aug/2015)

## Tips & Warnings

---



If AP LED turn on, BOOT LED turn off and ERR LED flash slow. It means that the value of rotary switch does not match the settings of the modules(please refer to section 4.2. Module configuration).

---

### ► Power Connector

---

| Pin Name | Function                |
|----------|-------------------------|
| +VS      | 10 ~ 30 VDC power input |
| GND      | Ground connection       |
| F.G.     | Frame ground connection |

## 1.5. Dimensions

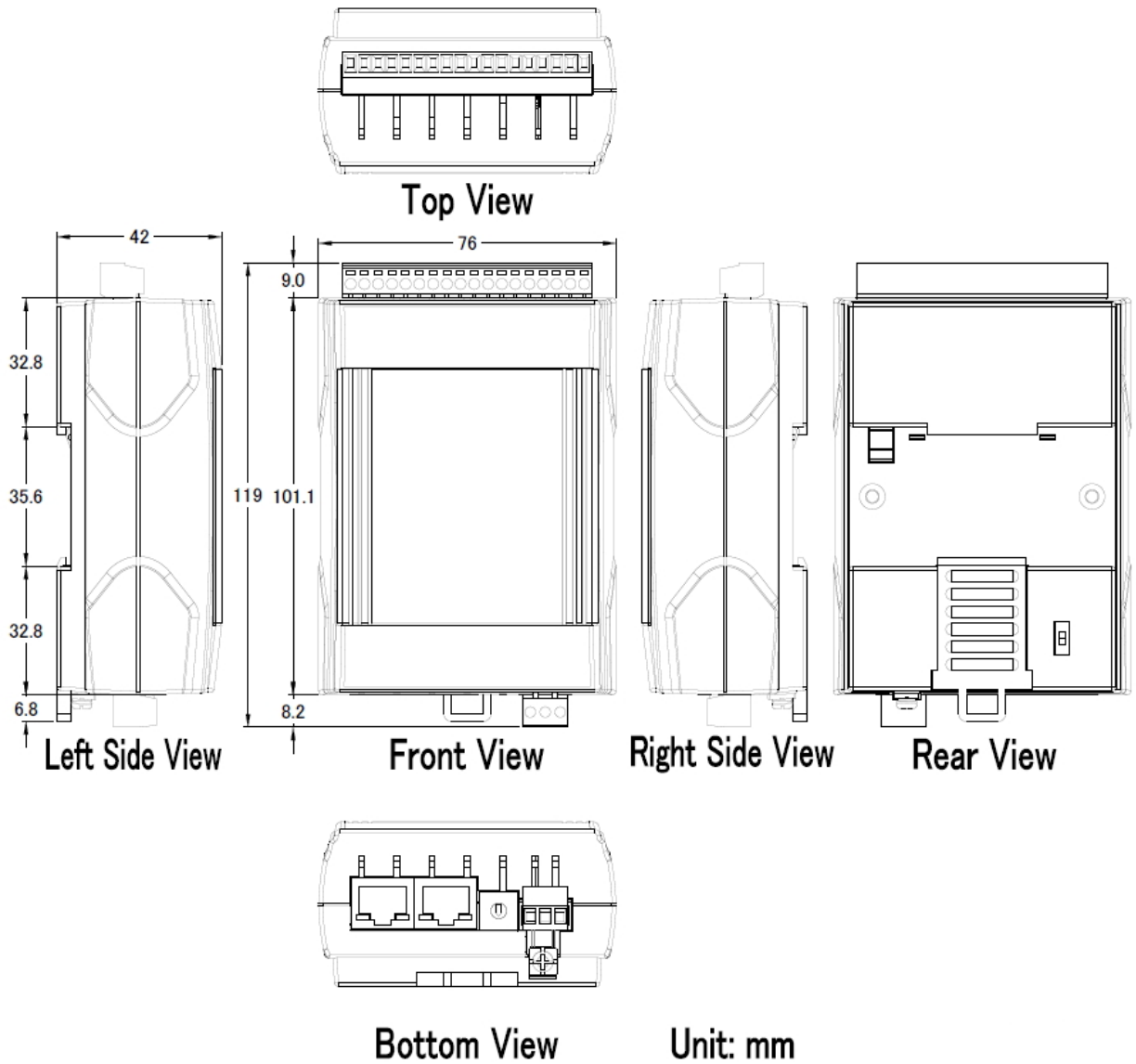

## 2. PROFINET

---

PROFINET contains 2 different solutions. They are PROFINET IO and PROFINET CBA (Component Based Automation). **GW-7663 module is a PROFINET IO device.**

PROFINET IO is used for communication with decentral periphery like IOs, drives, etc.

PROFINET CBA is a communication solution for autonomously acting partial units of machines or plants.

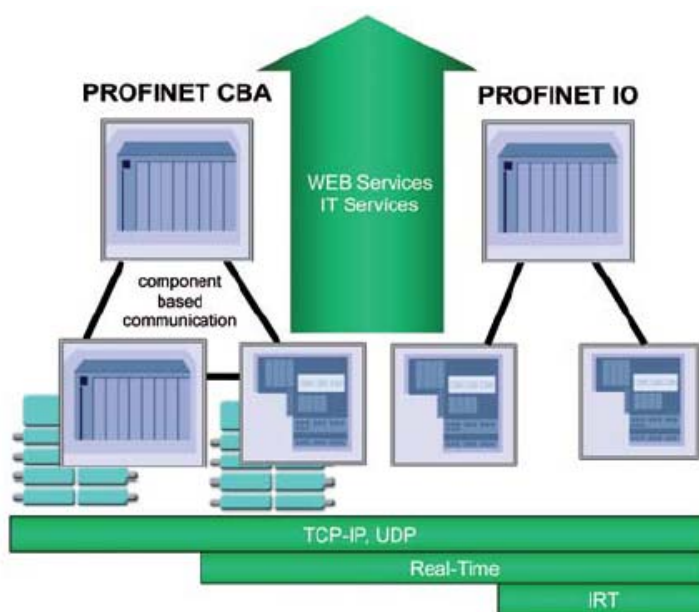

### 2.1. Device classes of PROFINET IO

The following devices classes are defined to facilitate structuring of PROFINET IO field devices.

- ◆ IO-Controller: This is typically a PLC on which the automation program runs
- ◆ IO-Supervisor: This can be a programming device (PG), personal computer (PC), or human machine interface (HMI) device for commissioning or diagnostic purposes.
- ◆ IO-Device: An IO-Device is a distributed I/O field device that is connected via PROFINET IO. It can exchange data with multiple IO-Controllers.

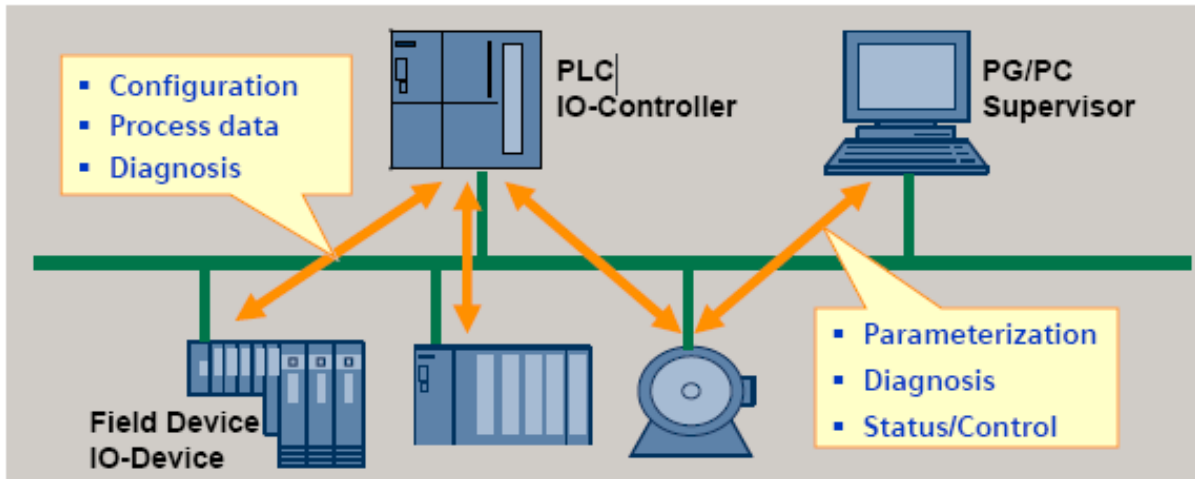

The functionality of a PROFINET IO Device is always described in a GSD file. This file contains all data that are relevant for engineering as well as for data exchange with IO-Device.

PROFINET IO-Devices can be described using XML-based GSD. The description language of the GSD file, i.e. GSDML (General Station Description Markup Language) is based on international standards.

Every manufacturer of a PROFINET IO-Device must supply an associated GSD file according to the GSDML specification. Users can access and configure GW-7663 module by using the GSDML file in any PROFINET Engineering tool.

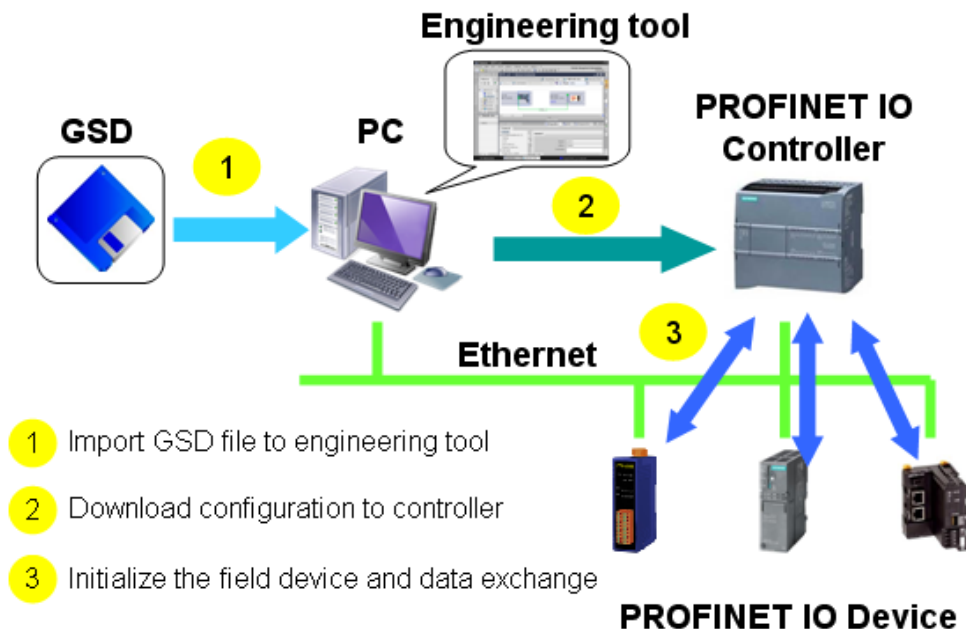



## 2.3. Conformance Classes (CC)

PI has classified the scope of functions in PROFINET IO into 3 conformance classes (CC-A, CC-B, CC-C). Users simply need to select a CC appropriate for system and do not need to worry about any other details to ensure the interoperability in an automation system with regard to the scope of functions and performance parameters.

### CC-A:

Use of the infrastructure of an existing Ethernet network including integration of basic PROFINET functionality. All IT services can be used without restrictions. Examples of typical applications are in building automation and process automation. Wireless communication is only possible in this class.

### CC-B:

In addition to the functions of CC-A, the scope of functions of CC-B supports easy and user-friendly device replacement without the need for an engineering tool. Examples of typical applications are in automation systems with a higher-level machine controller that place relatively low demands for a deterministic data cycle.

### CC-C:

In addition to the functions of CC-B, the scope of functions of CC-C supports high-precision and deterministic data transmission, including for isochronous applications. An example of a typical application is the field of motion control.



# 3. Basic Application

---

If you are a new user, begin with this chapter, it includes a guided tour that provides a basic overview of installing, configuring and using the GW-7663.

In the following examples the S7-1200 PLC from Siemens is used to be a PROFINET IO Controller. The configuration and communication is done by the program “Step 7 V11 SP2 (TIA PORTAL)” provided by Siemens.

## 3.1. Connect to Network, PC and PROFINET IO controller

The GW-7663 module is equipped with two RJ-45 Ethernet ports for connection to an Ethernet switch, PC and PROFINET IO controller.

### Tips & Warnings

---



1. When users connect GW-7663 and switch, users should not connect LAN1 and LAN2 to switch at the same time, else it will lead to abnormal network.
2. When users connect network devices by daisy chain topology, users can connect these devices in series by LAN1 and LAN2.

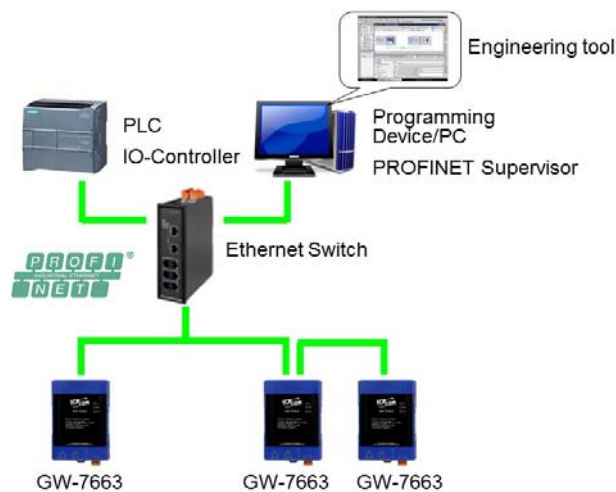

## 3.2. Network configuration

In this example, please follow the below configuration to configure the network.

PC:

IP: 192.168.6.210

Mask: 255.255.0.0

PLC:

Device name: plc1

IP: 192.168.6.211

Mask: 255.255.0.0

GW-7663:

Device name: gw-7663

IP: 192.168.6.212

Mask: 255.255.0.0

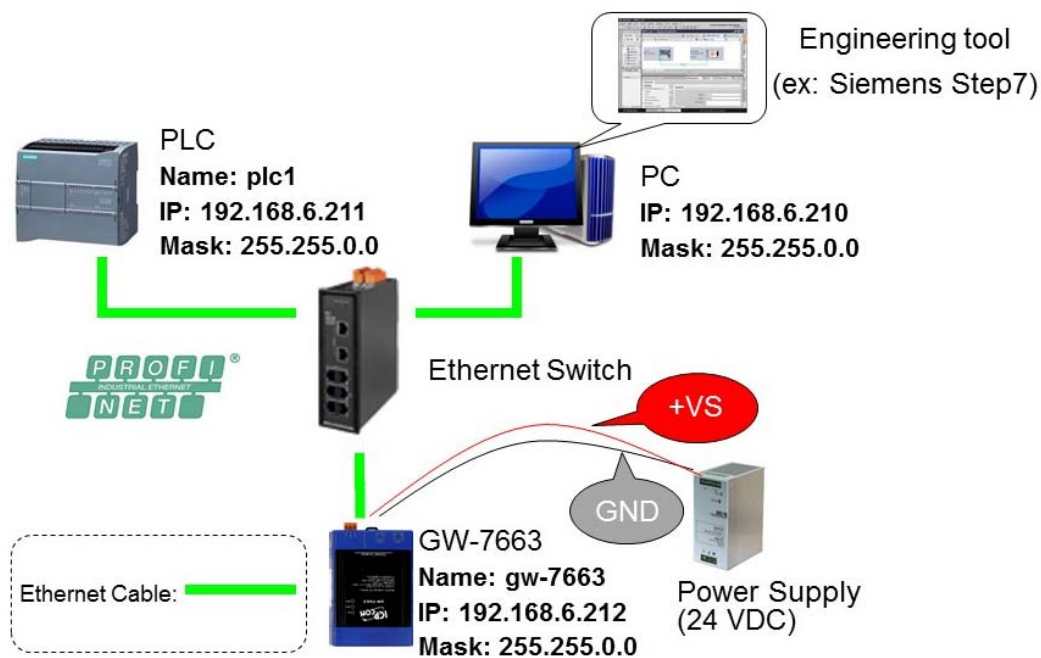

GW-7663 User Manual (Version 1.00, Aug/2015)

## Step 1: Set PC's IP

- ◆ Click “start->Settings->Network Connections”

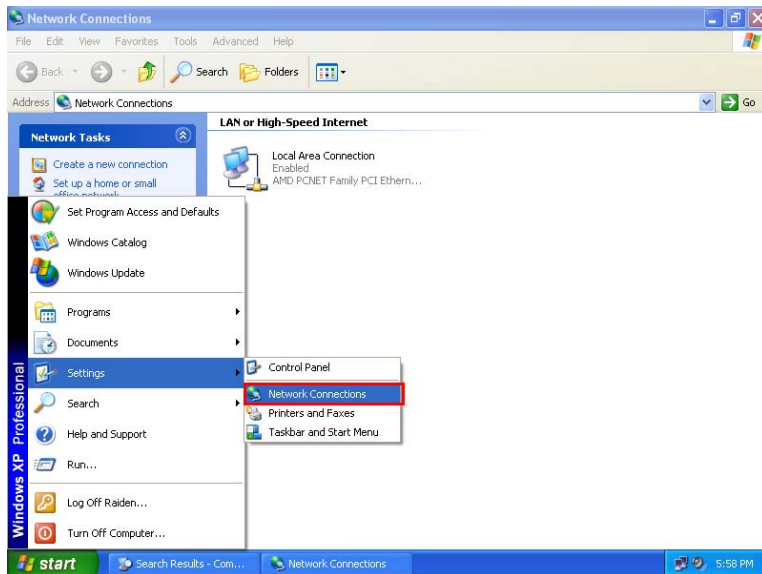

- ◆ Double click “Local Area Connection” icon



- ◆ Click “Properties” button

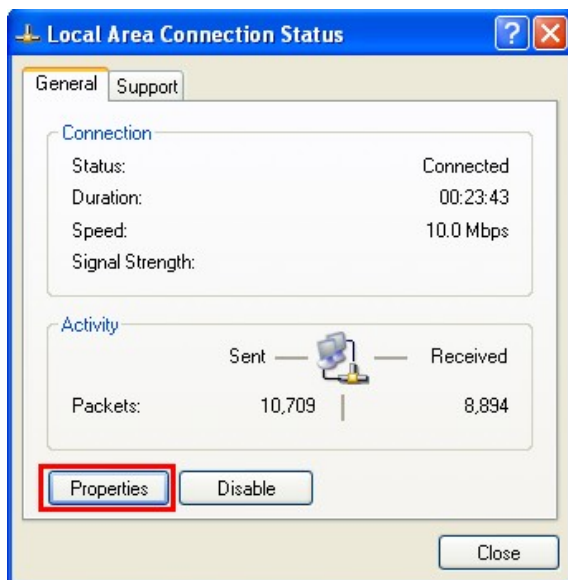

- ◆ Select “Internet Protocol(TCP/IP)” and click “Properties” button

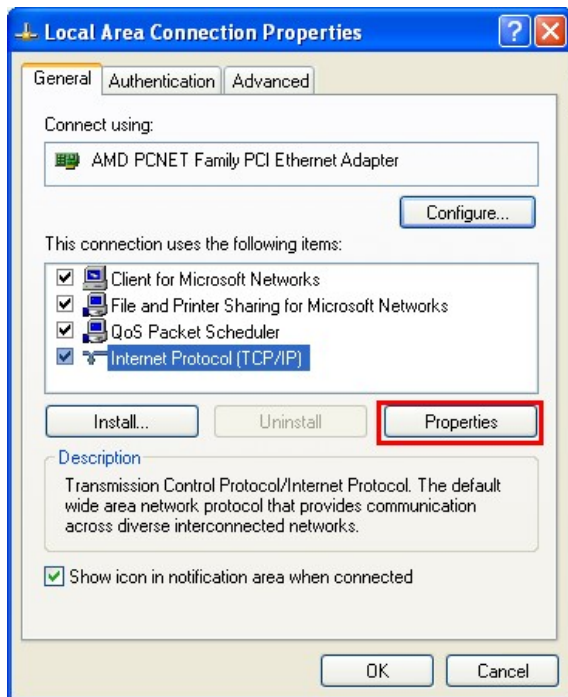

- ◆ Set “Internet Protocol Properties” and then click “OK” button.

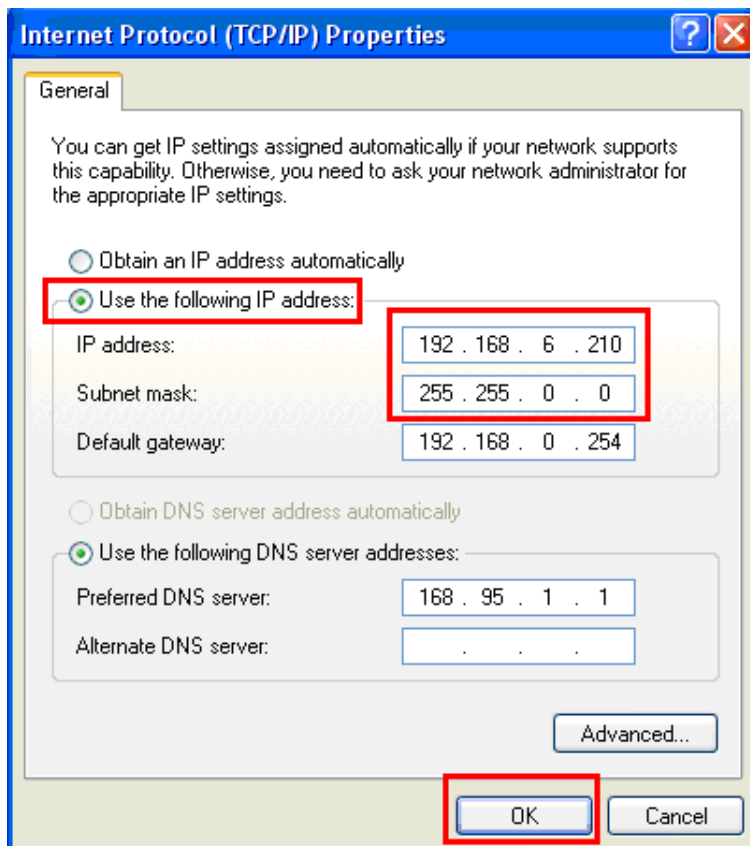

## Step 2: Set PLC's name and IP

- ◆ Double Click TIA icon to start Step 7 V11



- ◆ Click "Project view"

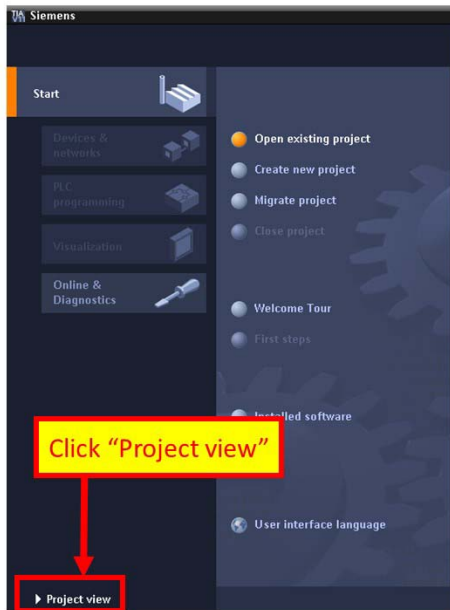

- ◆ Search accessible devices

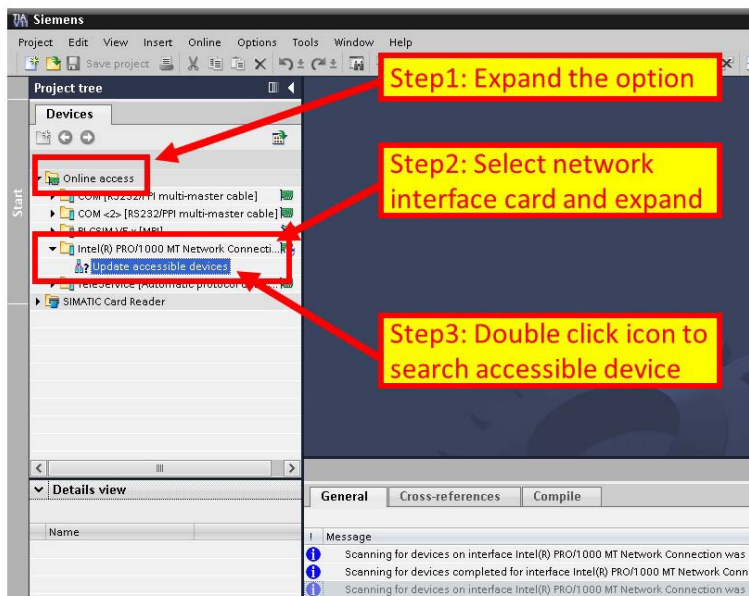



- ◆ Select PLC and click “Online & diagnostics” button

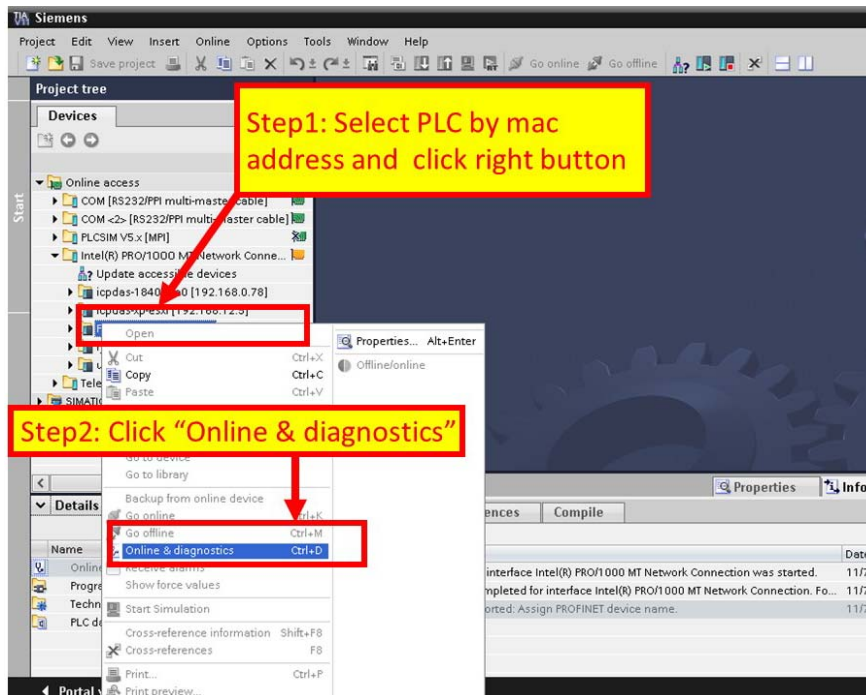

- ◆ Set IP and Mask

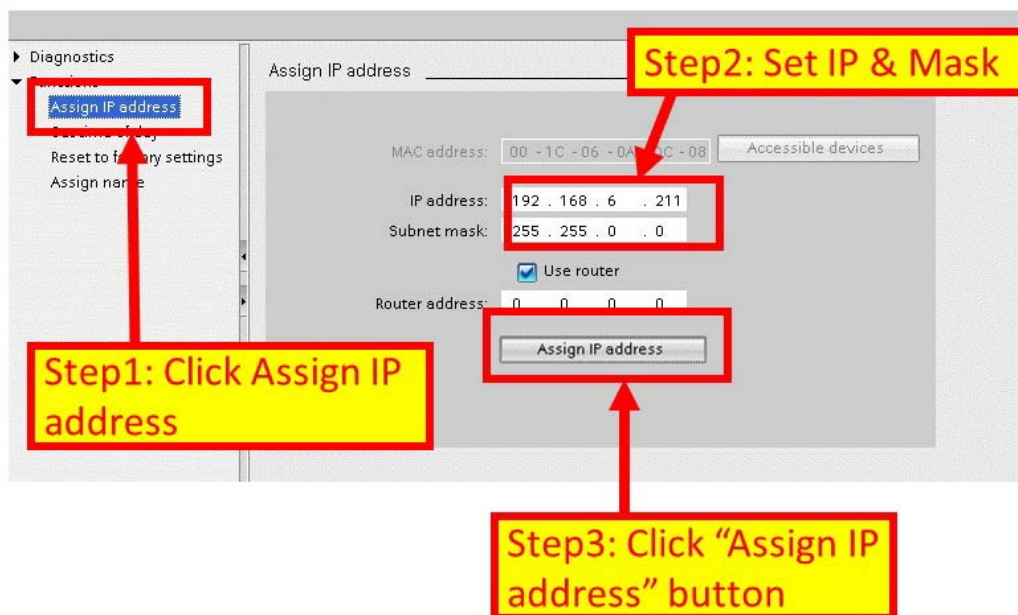

◆ Set device name

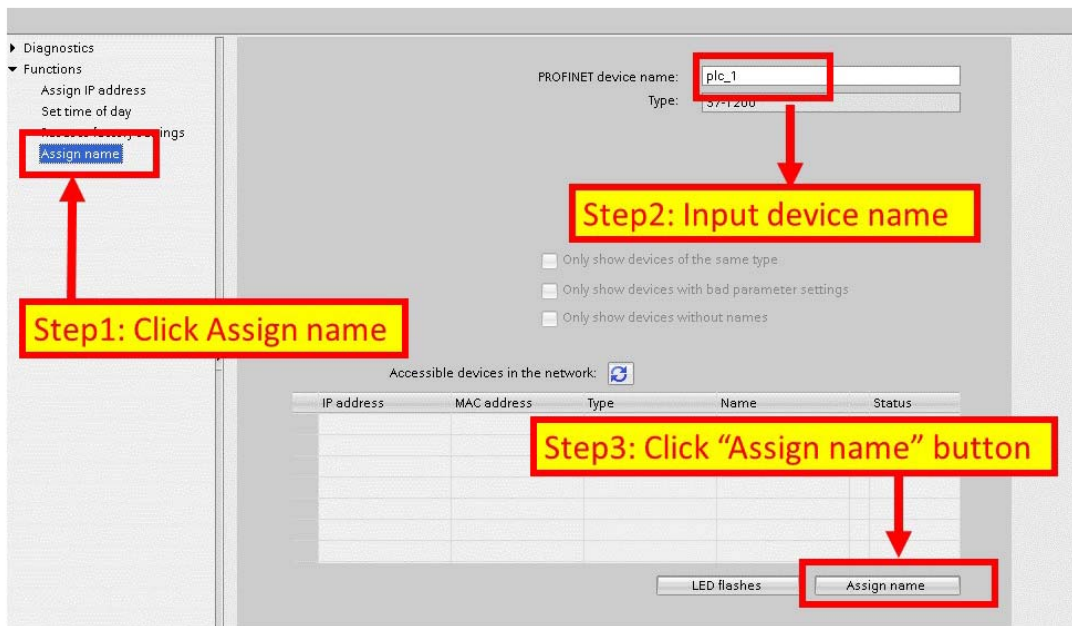

**Step 3: Set GW-7663 module's name and IP**

◆ Search accessible devices

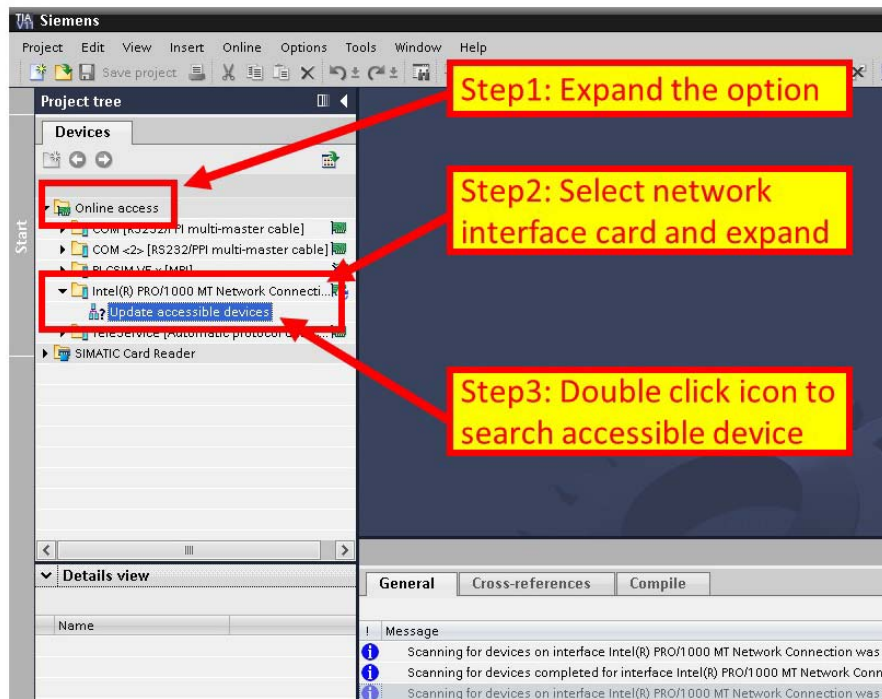



- ◆ Select GW-7663 module and click “Online & diagnostics” button

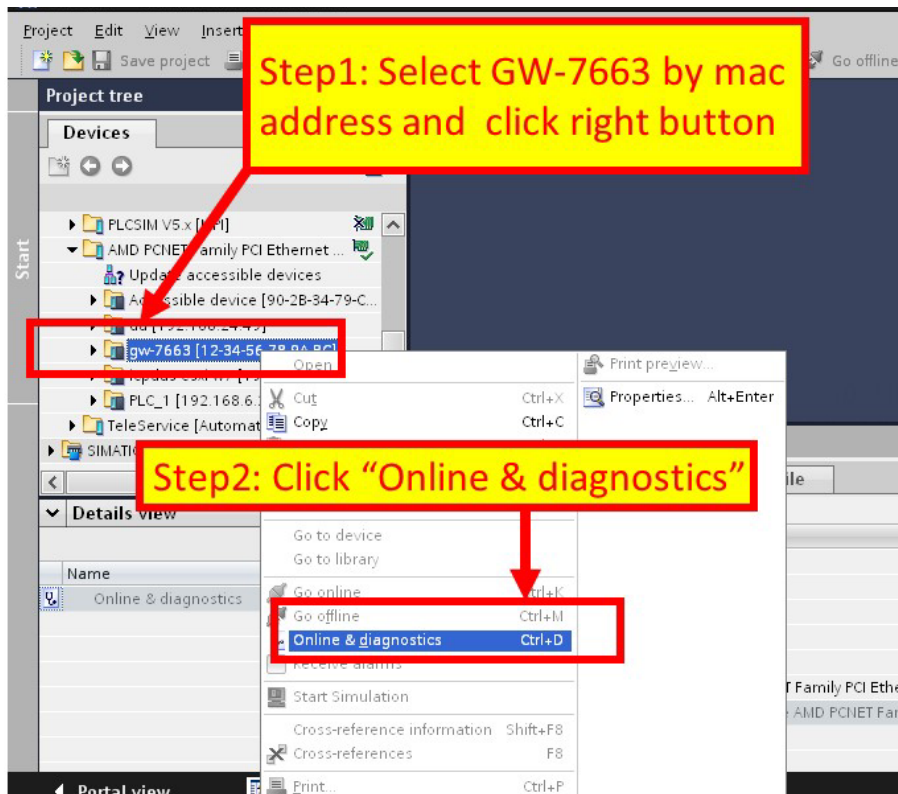

- ◆ Set IP and Mask

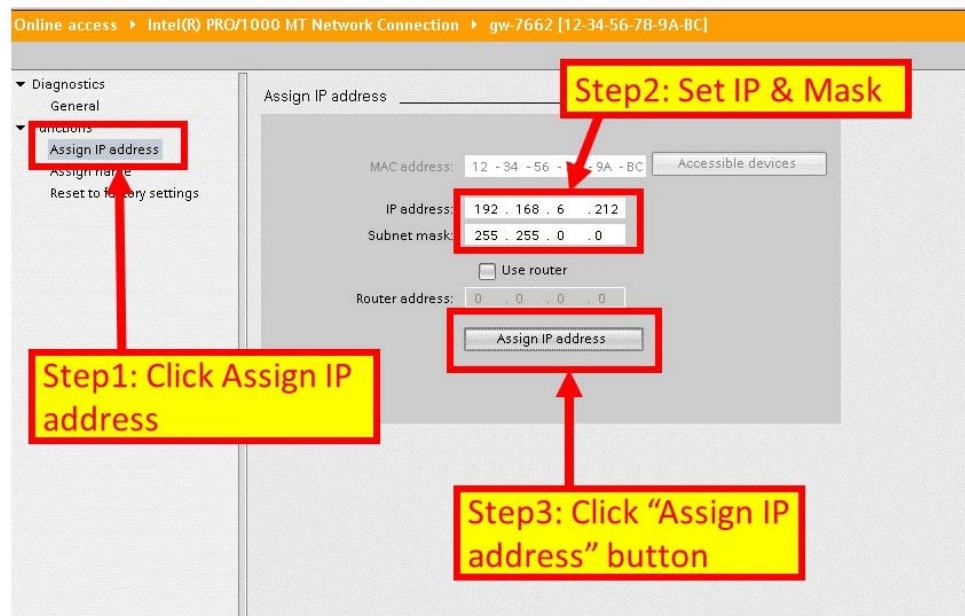

◆ Set device name

Step1: Click Assign name

Step2: Input device name

Step3: Click "Assign name" button

| IP address | MAC address | Type | Name | Status |
|------------|-------------|------|------|--------|
|            |             |      |      |        |
|            |             |      |      |        |
|            |             |      |      |        |
|            |             |      |      |        |
|            |             |      |      |        |

### 3.3. GSD Import

In this example, please follow the step to import GSD file.

#### Step 1: Get GSD file

The GSD file can be obtained from companion CD or our FTP site:

CD: \fieldbus\_cd\profinet\gateway\gw-7663\gsd\  
[ftp://ftp.icpdas.com/pub/cd/fieldbus\\_cd/profinet/gateway/gw-7663/gsd/](ftp://ftp.icpdas.com/pub/cd/fieldbus_cd/profinet/gateway/gw-7663/gsd/)

#### Step 2: Import GSD file

- ◆ Double Click TIA icon to start Step 7 V11



- ◆ Click "Project view"

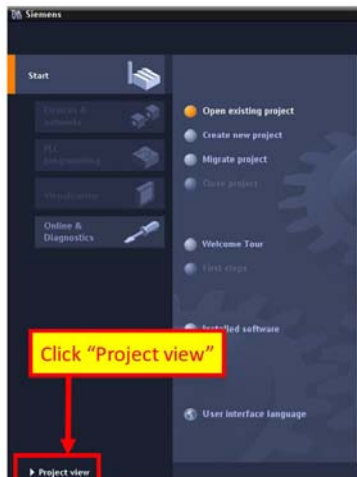

- ◆ Select “Menu->Options->Install general station description file (GSD)”

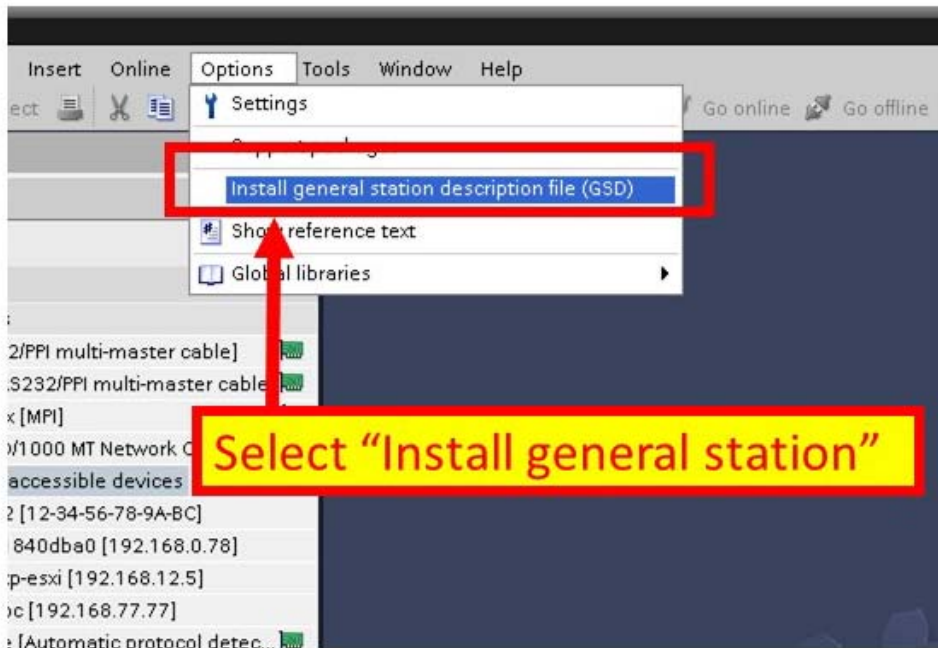

- ◆ Select and install GSD file

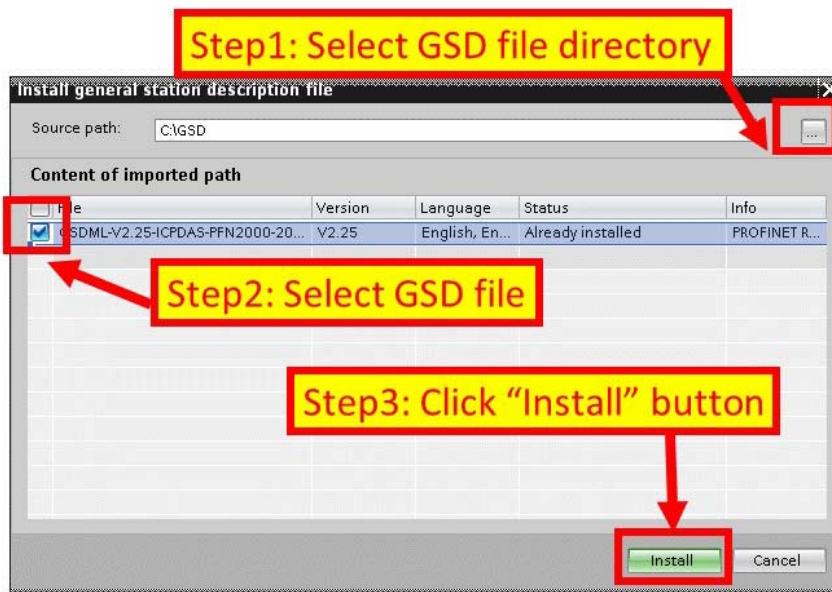

# 3.4. Project Setup

In this example, please follow the step to setup project.

## Step 1: Create the project

- ◆ Double Click TIA icon to start Step 7 V11

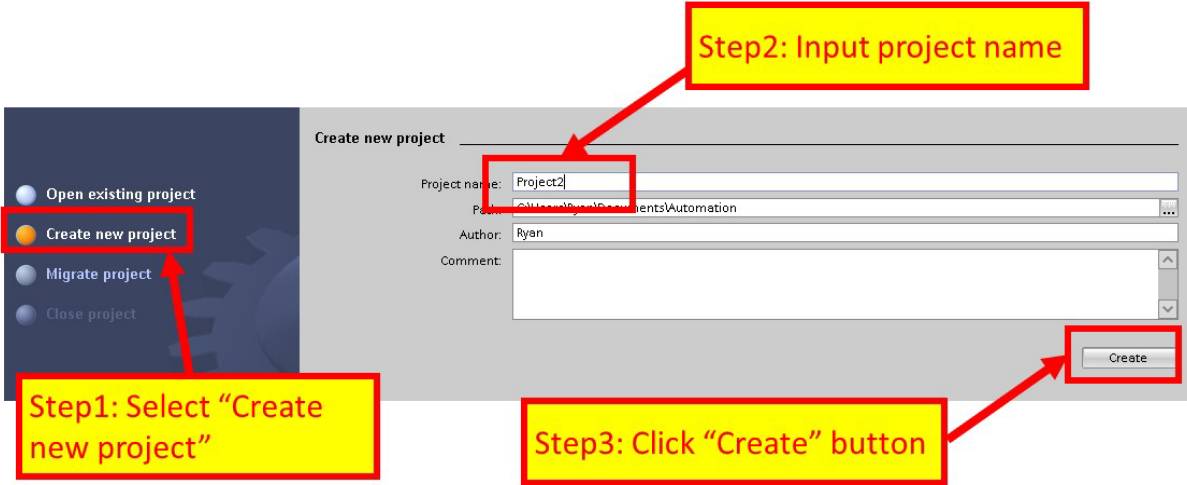

- ◆ Create the Project

The image is a screenshot of the 'Create new project' dialog box in TIA Portal. On the left side, there is a vertical list of options: 'Open existing project', 'Create new project', 'Migrate project', and 'Close project'. The 'Create new project' option is highlighted with a red box and a red arrow pointing to it from a yellow callout box that says 'Step1: Select "Create new project"'. The main area of the dialog box contains several input fields: 'Project name:' with the text 'Project2' entered and highlighted by a red box and a red arrow from a yellow callout box that says 'Step2: Input project name'; 'Path:' with the text 'C:\Users\Ryan\Desktop\Automation' and a dropdown arrow; 'Author:' with the text 'Ryan'; and 'Comment:' with an empty text area. At the bottom right of the dialog box, there is a 'Create' button, which is highlighted by a red box and a red arrow from a yellow callout box that says 'Step3: Click "Create" button'.

## Step 2: Project configuration

### ◆ Add a PLC device

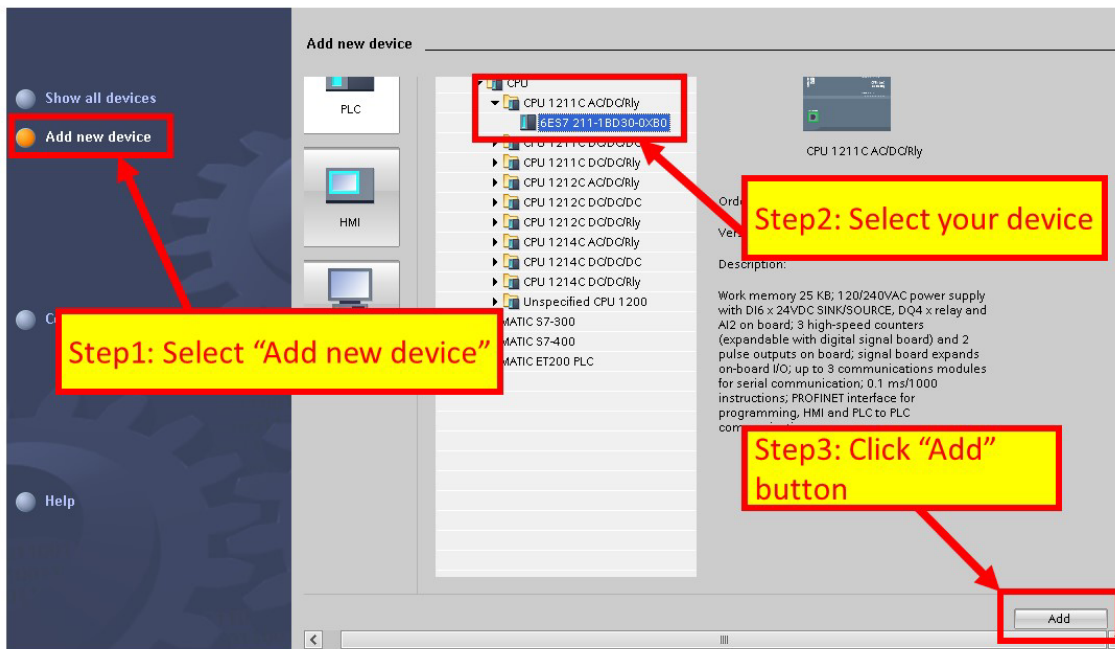
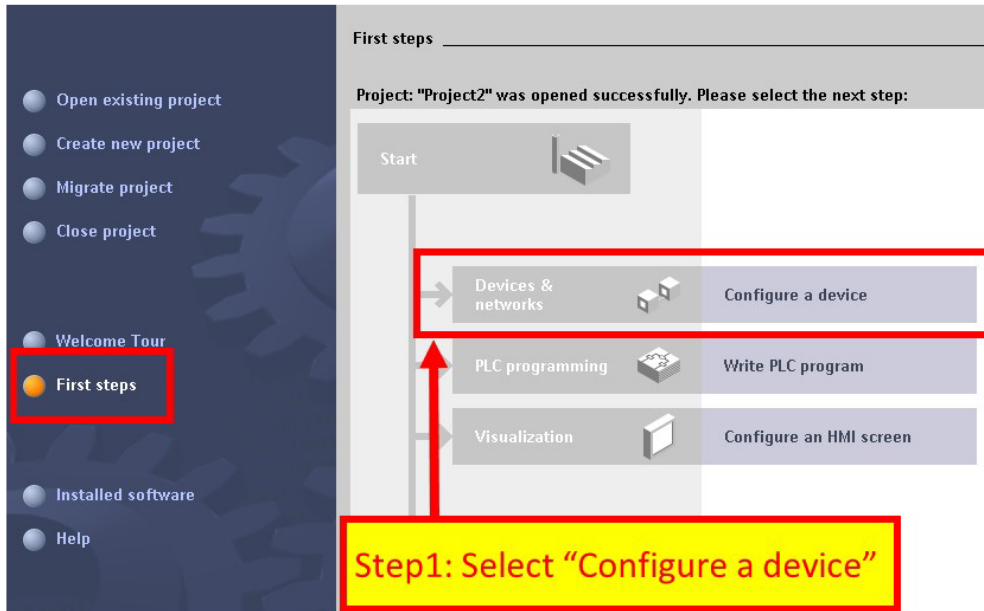



- ◆ Set the device name of PLC to “PLC\_1”

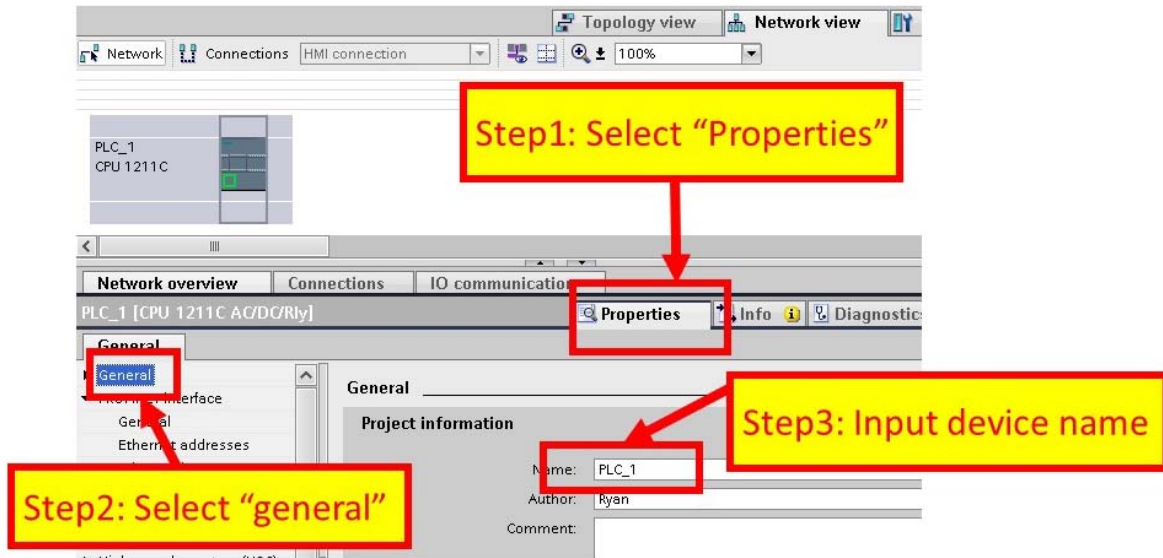

- ◆ Set the IP and mask of PLC and add a new subnet

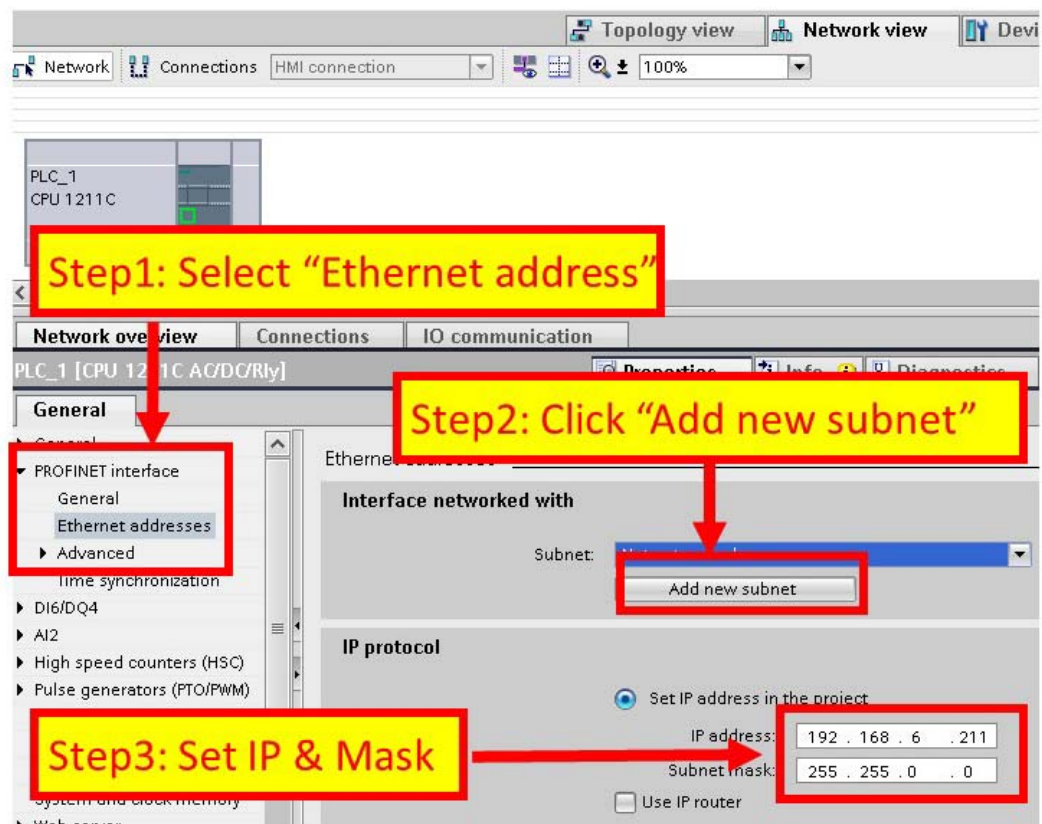

◆ Add GW-7663 module

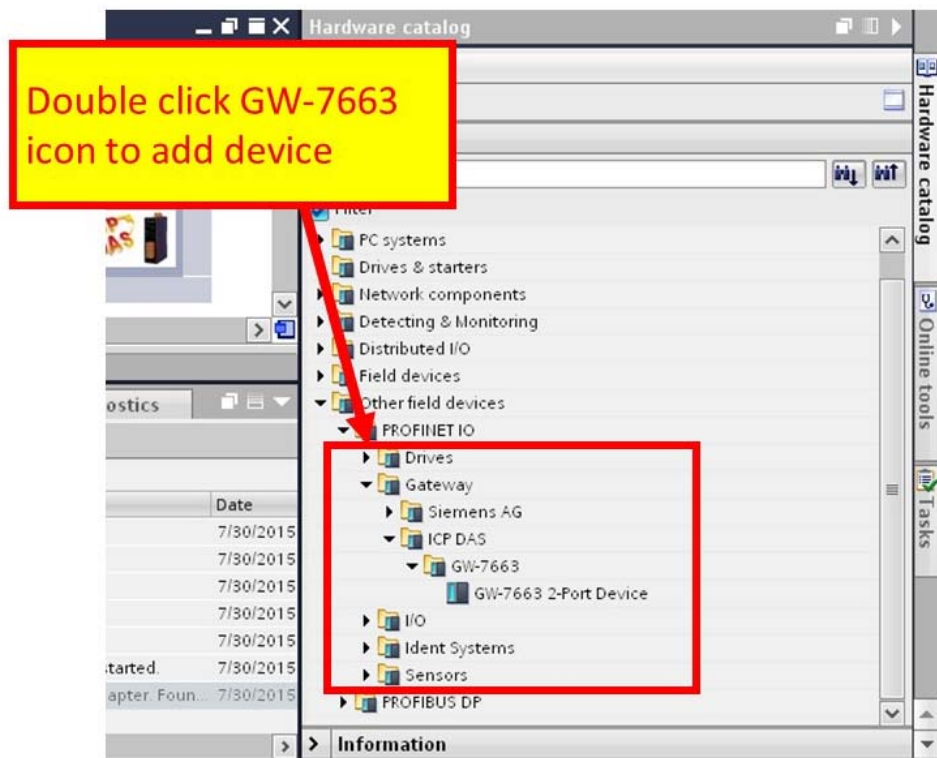

◆ Select PROFINET interface

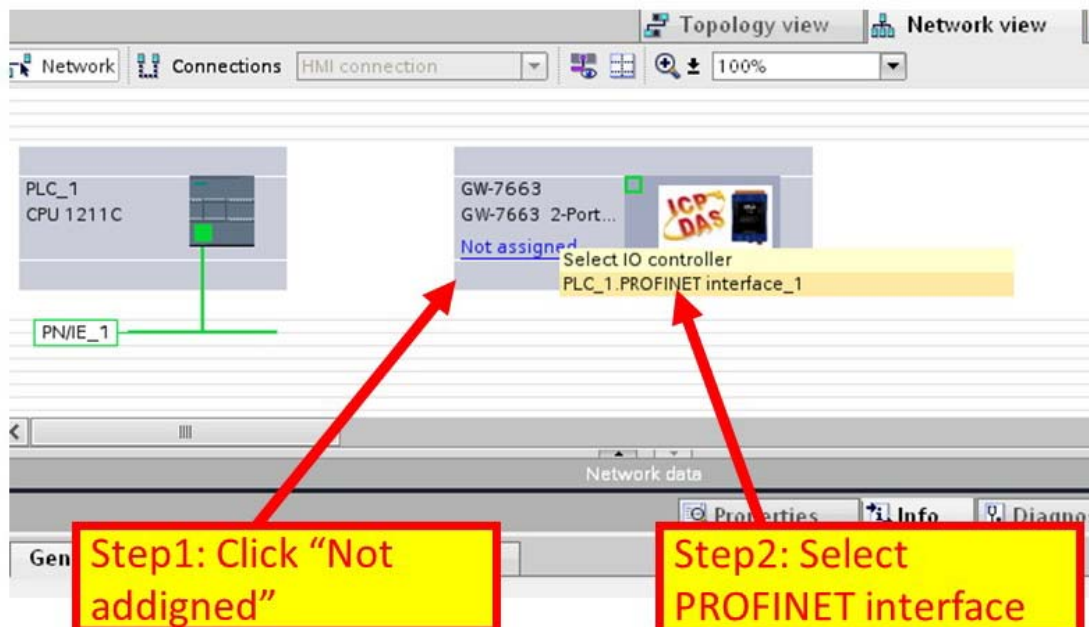



- ◆ Set device name to “gw-7663”

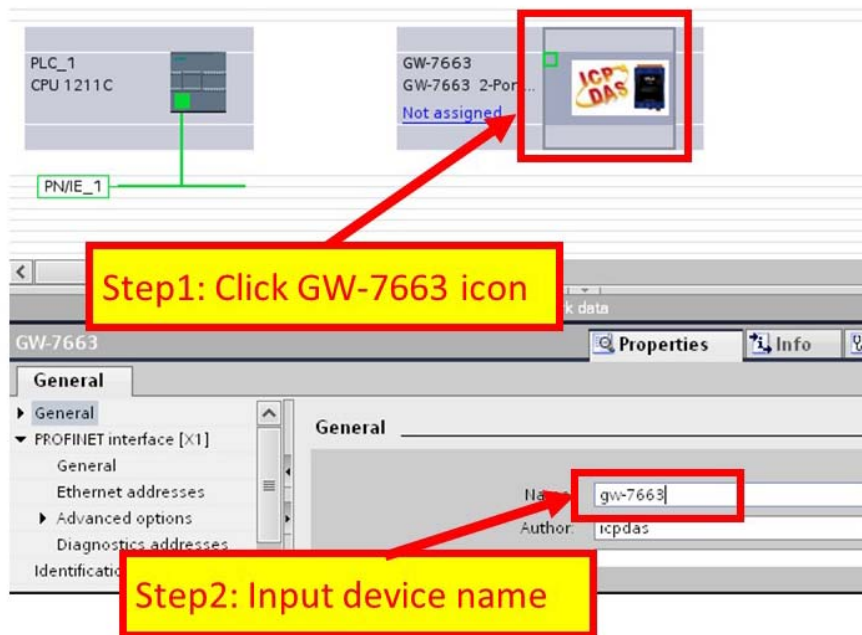

- ◆ Set the IP of GW-7663 module

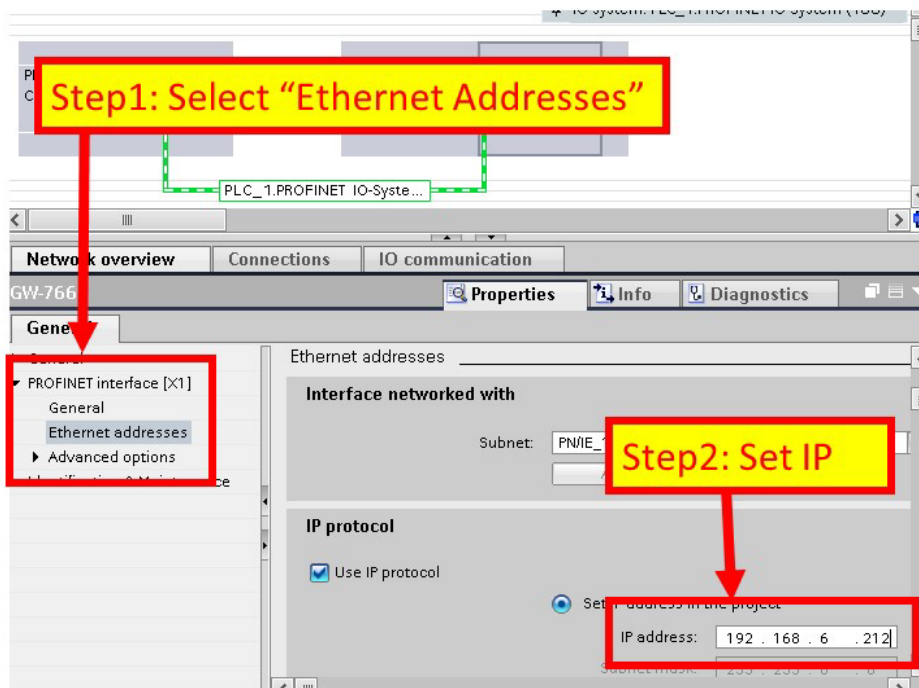

◆ Select module type of GW-7663 module

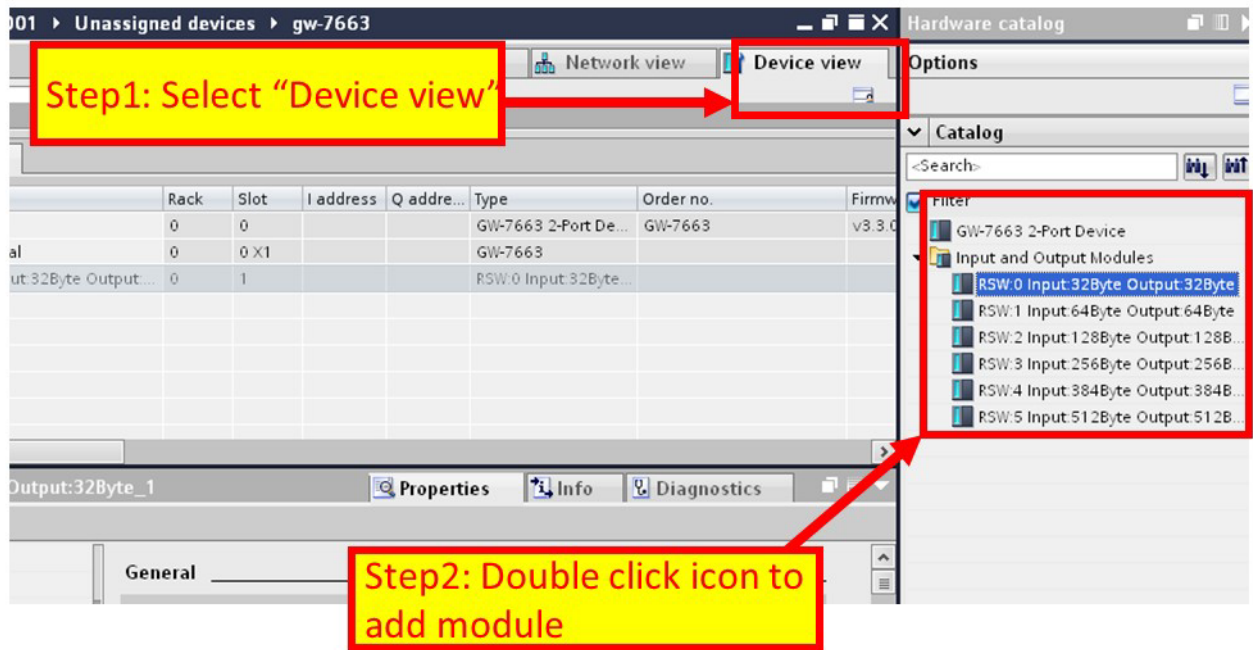

◆ Compile and download to device

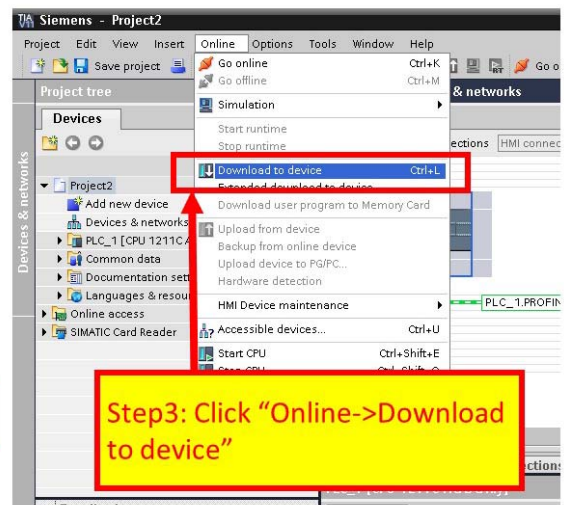
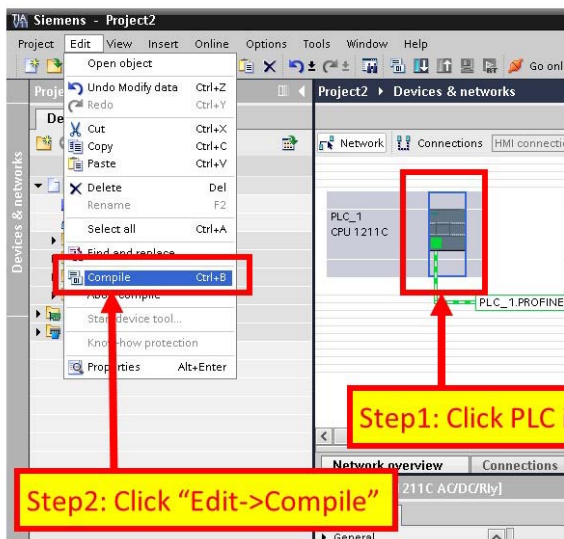

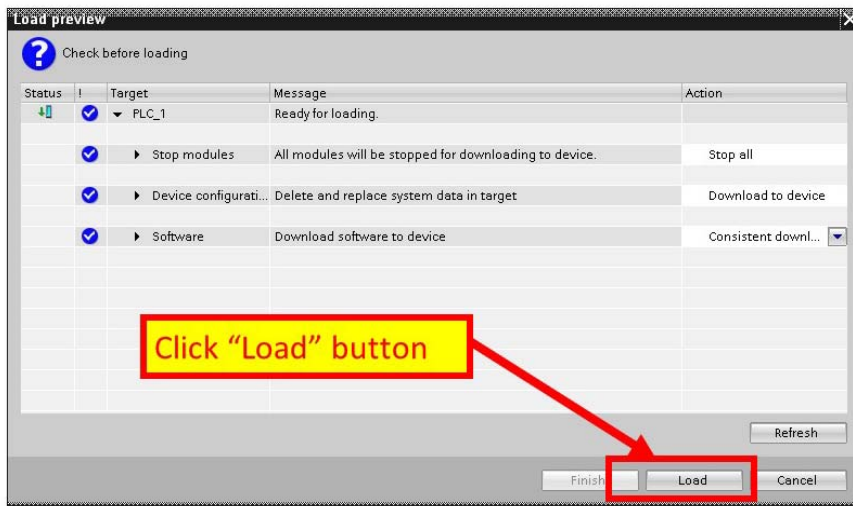
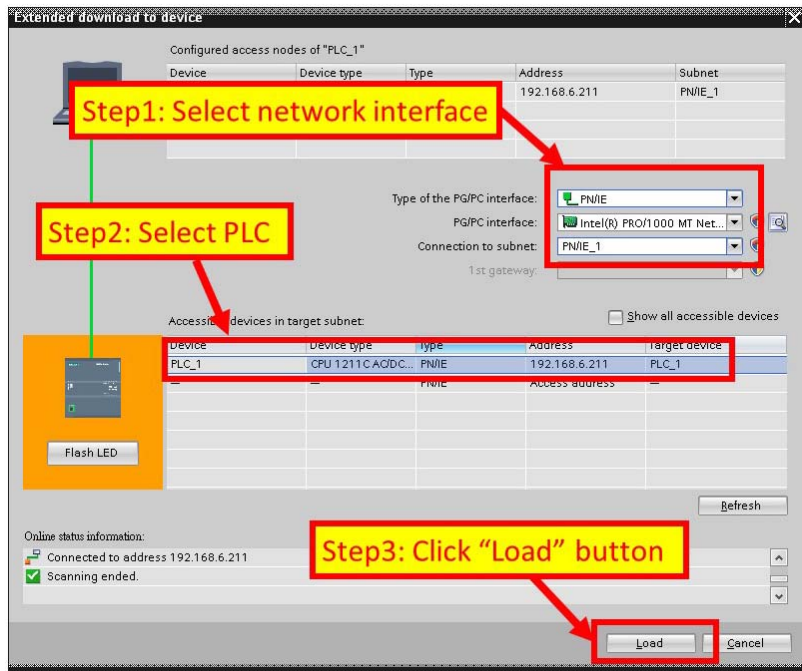

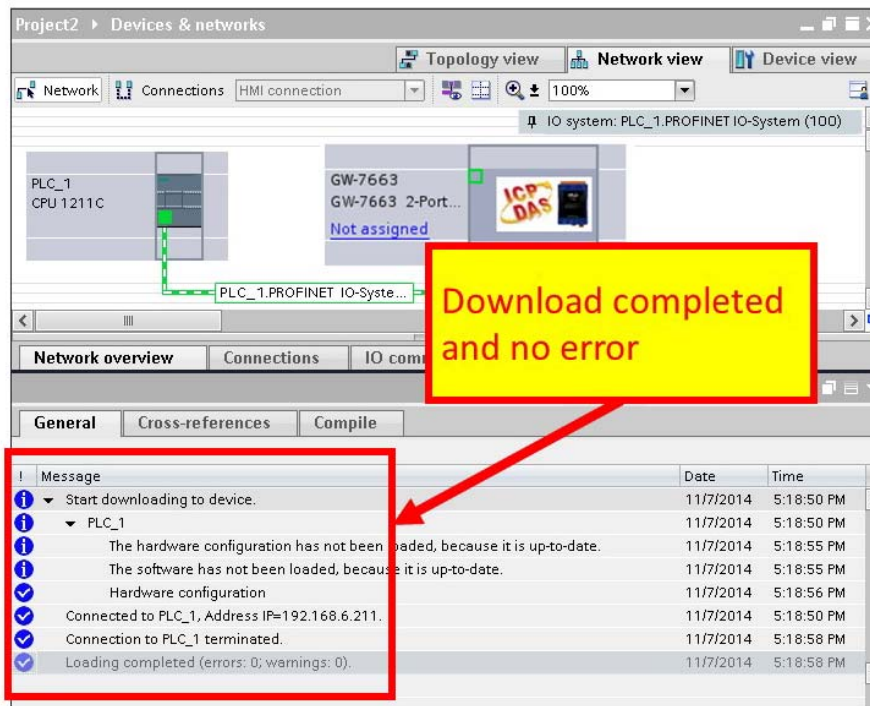
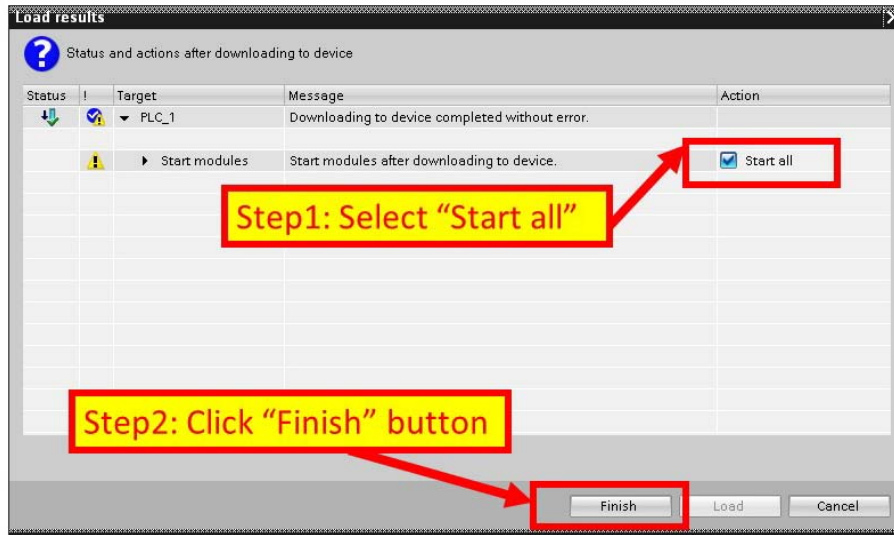

**At this time, the AP LED should turn on, BOOT LED and ERR LED should turn off, it means the connection between PLC and GW-7663 module is established.**

## 4. Communication

---

### 4.1. Communication Sequence

GW-7663 module has basically got 6 buffers:

- PROFINET IO device input buffer
- PROFINET IO device output buffer
- DI buffer
- DO buffer
- AI buffer
- AO buffer

PROFINET IO controller has basically got 2 buffers:

- PROFINET IO controller input buffer
- PROFINET IO controller output buffer

#### PROFINET Data Exchange

During each message cycle PROFINET IO controller writes the content of its output buffer to PROFINET IO device input buffer and reads the content of PROFINET IO device output buffer to its input buffer. The exchange cycle is taking place even though the content of the PROFINET IO controller and PROFINET IO device output buffer has not changed. The data flow between PROFINET IO controller and GW-7663 is shown in below.

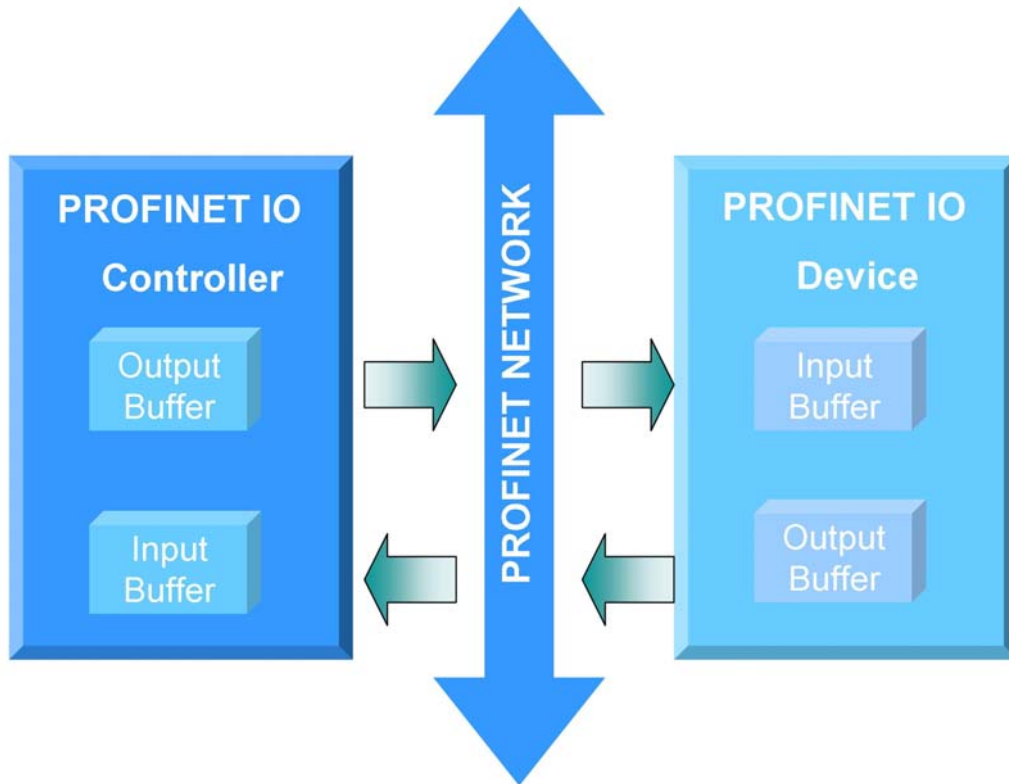

### Modbus Data Exchange – Master mode (Client)

When GW-7663 acts as a Modbus master device, it can get query message through parameters set by PFN\_Tool Utility and DO, AO buffer, and then send query message to Modbus slave device. It can also receive response message from Modbus slave device and then saving to internal DI, AI buffer.



## GW-7663 send data to Modbus slave device

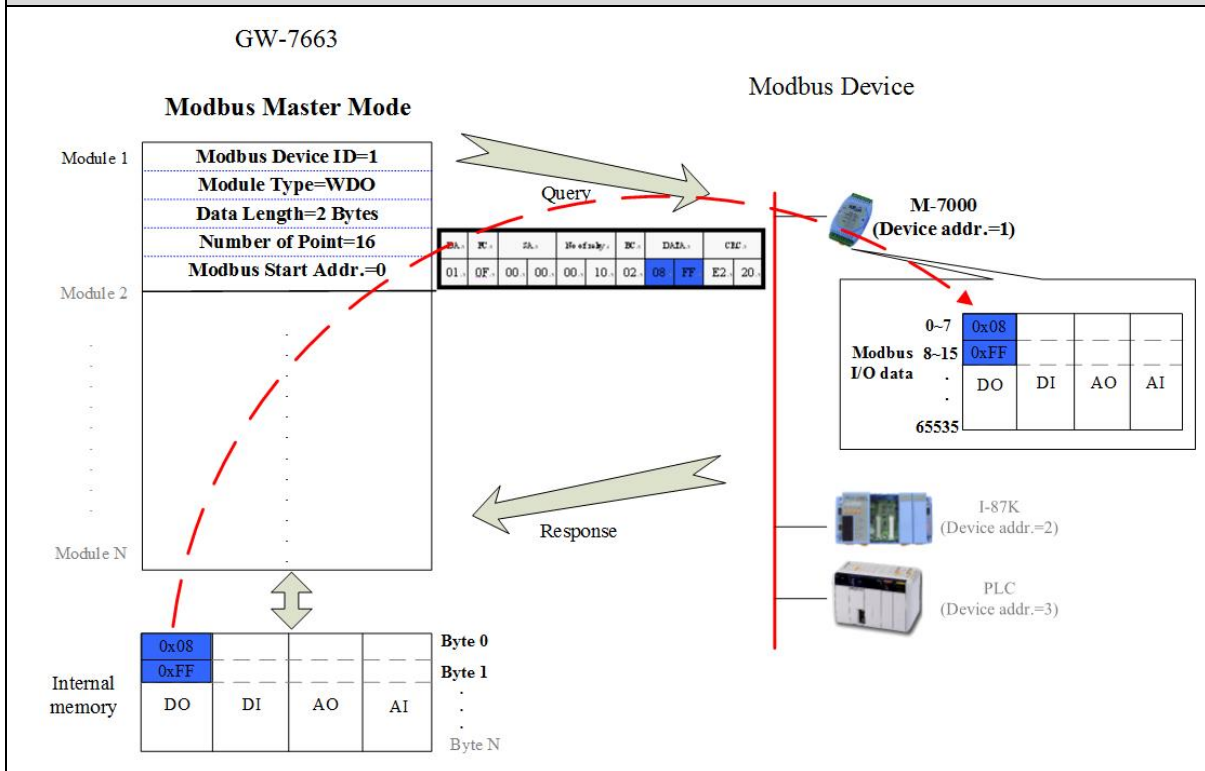

## GW-7663 receive data from Modbus slave device

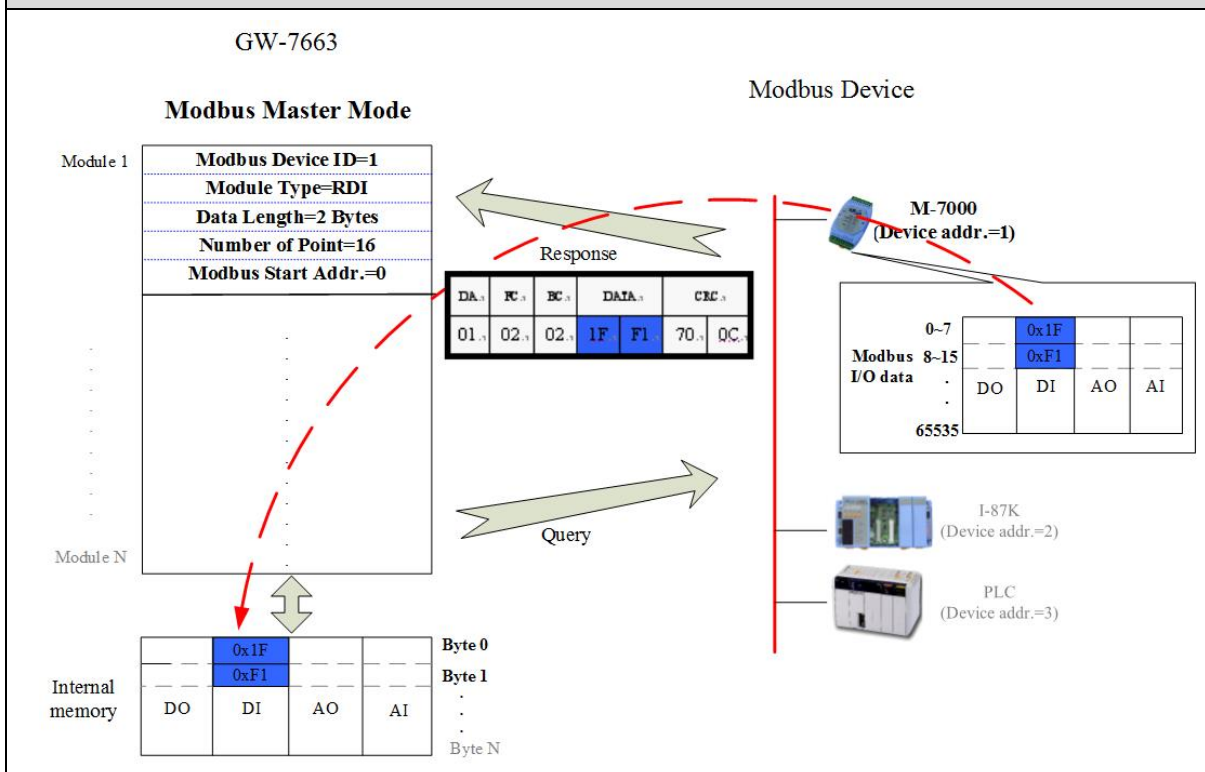

## Modbus Data Exchange – Slave mode (Server)

When GW-7663 acts as a Modbus slave device, it can receive query message from Modbus master device and then saving to internal DO, AO buffer. It can also send response message to Modbus master device through internal DI, AI buffer.

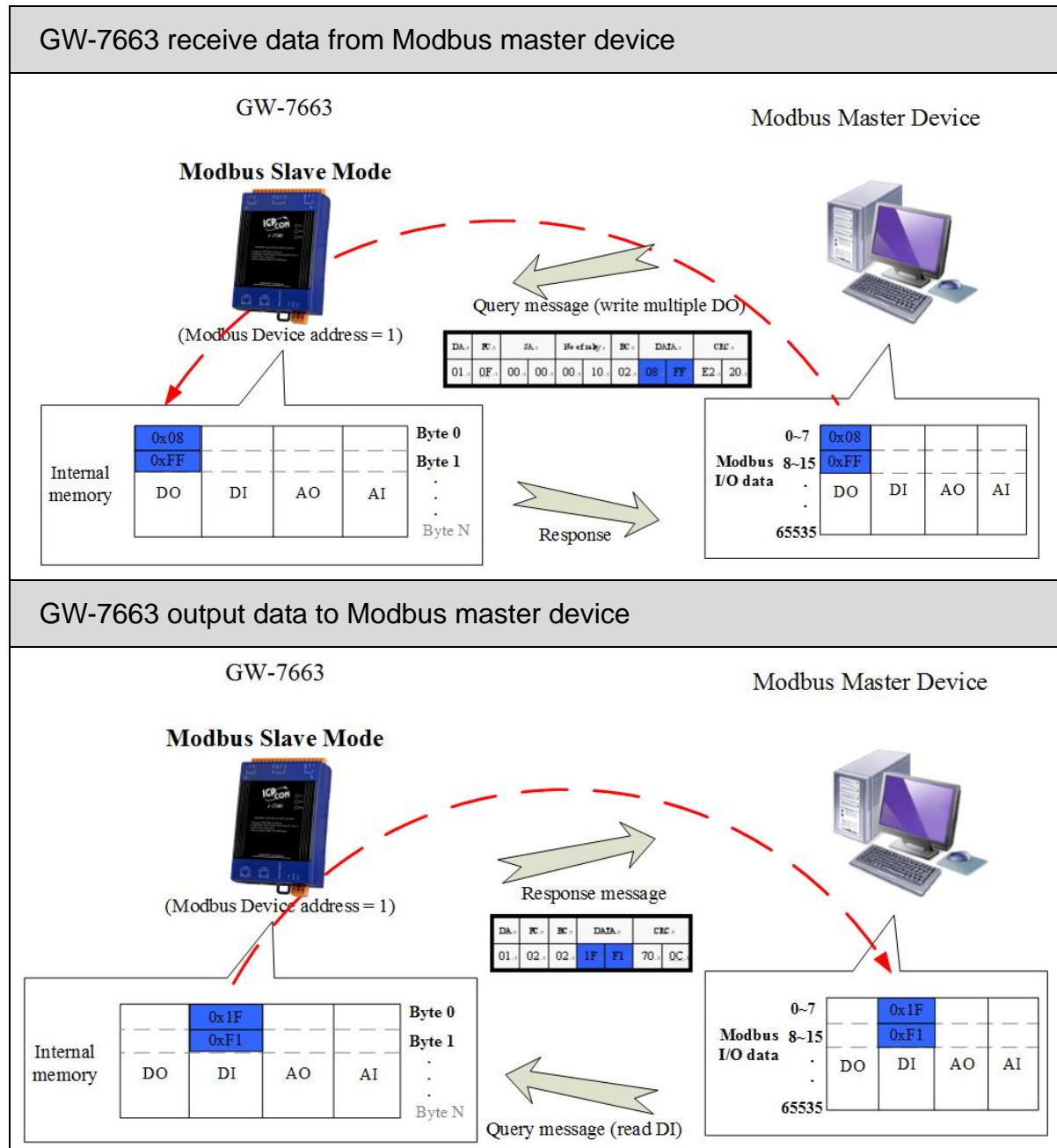



## 4.2. Module configuration

The user can set the size of the I/O modules in the PROFINET configuration tool. Each I/O module will allocate input 8 bytes and output 8 bytes for system. The settings of the modules are described below.

- Max. I/O modules: 1
- "RSW:0 Input:32Byte Output:32Byte" module
- "RSW:1 Input:64Byte Output:64Byte" module
- "RSW:2 Input:128Byte Output:128Byte" module
- "RSW:3 Input:256Byte Output:256Byte" module
- "RSW:4 Input:384Byte Output:384Byte" module
- "RSW:5 Input:512Byte Output:512Byte" module

### Tips & Warnings

---



If AP LED turn on, BOOT LED turn off and ERR LED flash slow. It means that the value of rotary switch does not match the settings of the modules(please refer to section1.4. Overview).

---

## 4.3. PROFINET Input Data Area

The maximum input data length of GW-7663 is 512 bytes. The first 8 bytes of the received input data are reserved for the communication status. The remaining data in the input data area represents the data packet received from the Modbus network.

| Byte  | Description                        |
|-------|------------------------------------|
| 1     | The number of diagnostic messages  |
| 2     | Type of diagnostic messages        |
| 3     | Description of diagnostic messages |
| 4     | Current used Modbus command module |
| 5~8   | Reserved                           |
| 9~512 | Received data from Modbus network  |

### ► Diagnostic message (byte 1~3)

---

EX: the data in byte1~3 is "0x02 0x01 0x0C". It means there are 2 diagnostic messages and the first message is "Modbus command module 1 send query message to Modbus slave device and doesn't receive any response message".

|      |                                 |
|------|---------------------------------|
| "02" | There are 2 diagnostic messages |
| "01" | Module 1 Error                  |
| "0C" | Response Message Timeout        |

### ► Received data (byte 9~512)

---

For more detail information, please refer to section4.6.1. PLC receives DI status from Modbus slave

## 4.4. PROFINET Output Data Area

The maximum output data length of GW-7663 is 512 bytes. The first 8 bytes are belong to communication commands.

| Byte  | Description                   |
|-------|-------------------------------|
| 1     | Reserved                      |
| 2     | Control bit                   |
| 3~8   | Reserved                      |
| 9~512 | Output data to Modbus network |

### ► Control bit (byte 2)

---

Bit 0: When this bit is set, diagnostic messages send by the GW-7663 module will all be cleared.

Bit 1~7: The remaining bits have to be set to zero.

### ► Output data (byte 9~512)

---

For more detail information, please refer to section 4.6.2. PLC refreshes DO status to Modbus slave.

## 4.5. Diagnostic Messages

The GW-7663 module can record maximally 32 diagnostic messages at the same time. If the number of the diagnostic messages is bigger than 32, the GW-7663 will not process other diagnostic message.

| Type                              | Description                     |
|-----------------------------------|---------------------------------|
| Module 1~128 Error<br>(0x01~0x0D) | Illegal Function (0x01)         |
|                                   | Illegal Data Address (0x02)     |
|                                   | Illegal Data Value (0x03)       |
|                                   | Slave Device Failure (0x04)     |
|                                   | Acknowledge (0x05)              |
|                                   | Slave Device Busy (0x06)        |
|                                   | Negative Acknowledge (0x07)     |
|                                   | Memory Parity Error (0x08)      |
|                                   | Modbus Not Defined Error (0x09) |
|                                   | Gateway Path Unavailable (0x0A) |
|                                   | Device Failed to Respond (0x0B) |
|                                   | Response Message Timeout (0x0C) |
|                                   | CRC(LRC) Error (0x0D)           |

### ► Module Error

---

For more detail description of diagnostic message, please refer to section 8.1. Modbus Exception Code.

### Tips & Warnings

---



1. These Diagnostic messages are not supported when GW-7663 act as a Modbus slave
-

# 4.6. Data exchange example

The configuration of PROFINET, please refer to section 3.4. Project Setup. About PROFINET IO module, please select **"RSW:0 Input:32Byte Output:32Byte"**

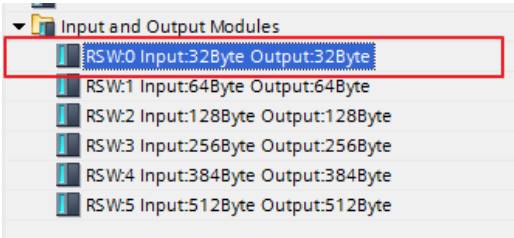

The first input 8 bytes and output 8 bytes are allocated for system. The 9th byte to the 32th byte are allocated for Modbus.

| Device overview |   |      |      |           |           |                       |   |
|-----------------|---|------|------|-----------|-----------|-----------------------|---|
| ...             | Module  | Rack | Slot | I address | Q address | Type                  |   |
|                 | <ul style="list-style-type: none"> <li>GW-7662                             <ul style="list-style-type: none"> <li>Internal</li> <li>RSW:0 Input:32Byte Output:32Byte_1</li> </ul> </li> </ul> | 0    | 0    |           |           | GW-7662 2-Port De...  | G |
|                 |   | 0    | 0 X1 |           |           | GW-7662               |   |
|                 |   | 0    | 1    | 1...32    | 1...32    | RSW:0 Input:32Byte... |   |

In the following two example, PROFINET IO controller communicate with ET-7026(Modbus slave) via GW-7663.

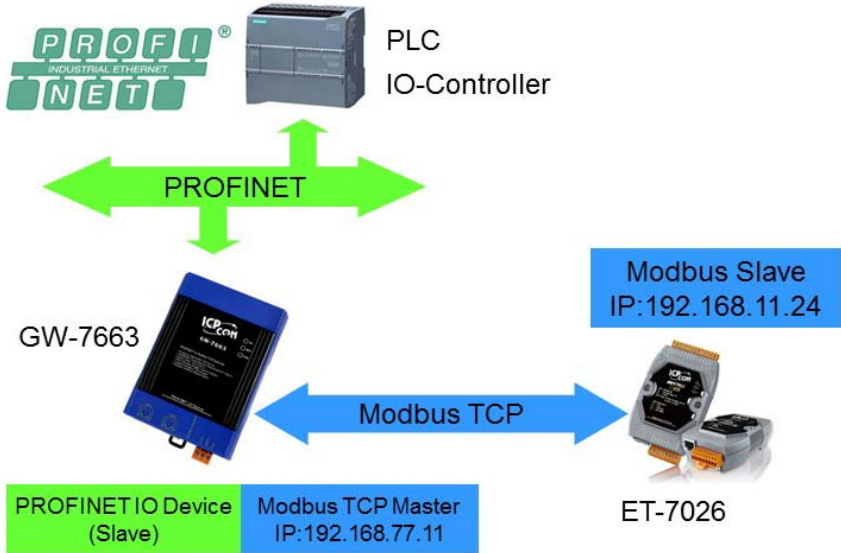

## 4.6.1. PLC receives DI status from Modbus slave

**Modbus Settings**

1 搜尋模組

2 雙擊模組

3 按「Advanced Settings」鈕

1

---

Device Information: Device Type: GW-7663, Firmware Version: V1.0

Modbus Settings: Modbus Type: Master(Client), Polling Interval (ms): 500, Server settings: Server NO.: 0, IP: 192.168.11.24, Re-Connect Time (ms): 8000

Request Command: FC4 Read multiple input registers (3xxxx) for AI

| Server NO. | ID | FC | Start Addr. | Count | Word order | PFN Input Addr. (Byte) | PFN Output Addr. (Byte) |
|------------|----|----|-------------|-------|------------|------------------------|-------------------------|
| 1          | 0  | 1  | 4 (RAI)     | 0     | 6          | No                     | 8-19                    |
| 2          | 0  | 1  | 16 (WAO)    | 0     | 2          | No                     | N/A                     |
| 3          | 0  | 1  | 2 (RDI)     | 0     | 2          | No                     | 20-20                   |
| 4          | 0  | 1  | 15 (WDO)    | 0     | 2          | No                     | N/A                     |

Suggested Module: RSW:0 Input:32Byte Output:32Byte

Press 『Upload Settings』 to save settings

2

3

## Communication test

Get DI status from web server of ET-7026(OFF, ON)

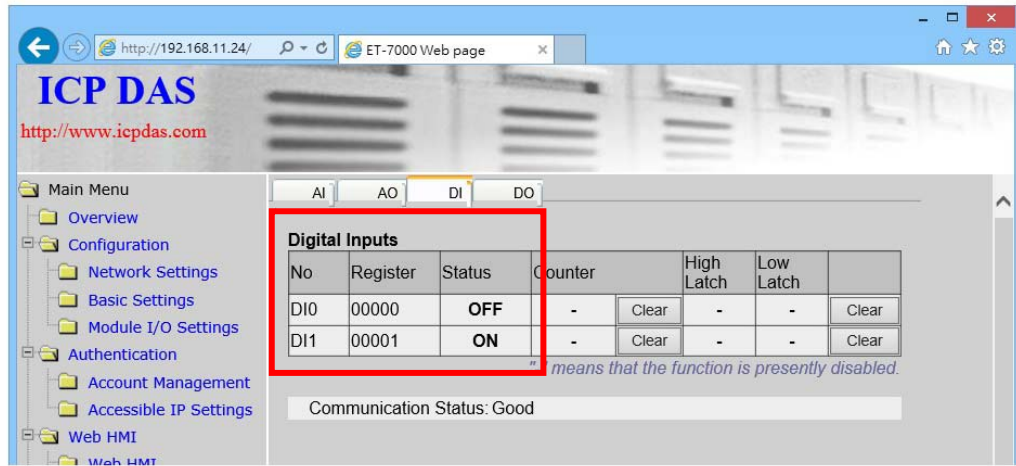

The screenshot shows the ICP DAS ET-7000 Web page. The browser address bar displays "http://192.168.11.24/" and "ET-7000 Web page". The page title is "ICP DAS" with the URL "http://www.icpdas.com". A navigation menu on the left includes "Main Menu", "Overview", "Configuration", "Network Settings", "Basic Settings", "Module I/O Settings", "Authentication", "Account Management", "Accessible IP Settings", "Web HMI", and "Web HMT". The "DI" tab is selected, showing a "Digital Inputs" table. The table has columns for "No", "Register", "Status", "Counter", "High Latch", and "Low Latch". The "Status" column shows "OFF" for DI0 and "ON" for DI1. Below the table, the "Communication Status" is "Good".

| No  | Register | Status | Counter | High Latch | Low Latch |
|-----|----------|--------|---------|------------|-----------|
| DI0 | 00000    | OFF    | -       | -          | -         |
| DI1 | 00001    | ON     | -       | -          | -         |

Communication Status: Good

1

PLC will receives DI status(OFF, ON) at PLC address I21.0, I21.1

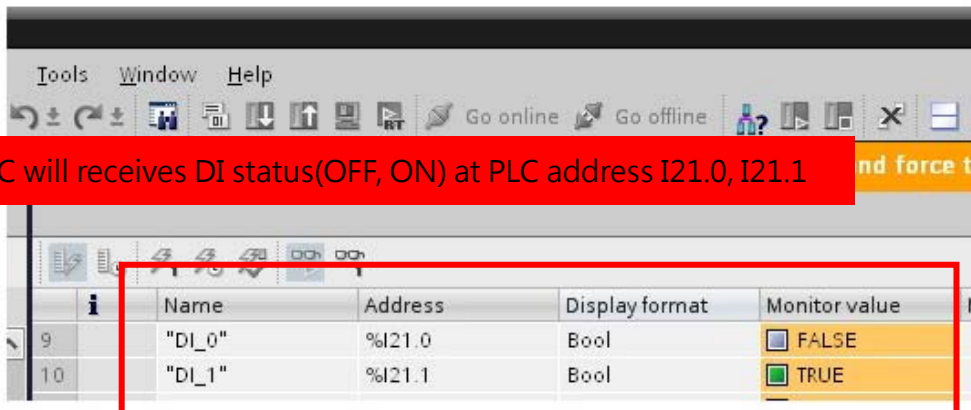

The screenshot shows the PLC software interface. The menu bar includes "Tools", "Window", and "Help". The toolbar contains various icons for navigation and control. A table displays the status of digital inputs:

| Name   | Address | Display format | Monitor value                            |
|--------|---------|----------------|--|
| "DI_0" | %I21.0  | Bool           | <input type="checkbox"/> FALSE           |
| "DI_1" | %I21.1  | Bool           | <input checked="" type="checkbox"/> TRUE |

2



## 4.6.2. PLC refreshes DO status to Modbus slave

**Modbus Settings**

1 搜尋模組

2 雙擊模組

3 按「Advanced Settings」鈕

1

---

Device Information: Device Type: GW-7663, Firmware Version: V1.0

Modbus Settings: Modbus Type: Master(Client), Polling Interval (ms): 500, Query Timeout (ms): 1000, I/O Safe Mode: Last Value, Modbus Device ID (dec): 1

Server settings: Server NO.: 0, IP: 192.168.11.24, Re-Connect Time (ms): 8000

| Server NO. | ID | FC | Start Addr. | Count | Word order | PFN Input Addr. (Byte) | PFN Output Addr. (Byte) |
|------------|----|----|-------------|-------|------------|------------------------|-------------------------|
| 1          | 0  | 1  | 4 (RAI)     | 0     | 6          | No                     | 8-19                    |
| 2          | 0  | 1  | 16 (WAO)    | 0     | 2          | No                     | N/A                     |
| 3          | 0  | 1  | 2 (RDI)     | 0     | 2          | No                     | 20-20                   |
| 4          | 0  | 1  | 15 (WDO)    | 0     | 2          | No                     | N/A                     |

Suggested Module: RSW:0 Input:32Byte Output:32Byte

Press 『Upload Settings』 to save settings

2

3

## Communication test

Get DO status from web server of ET-7026(OFF, OFF)

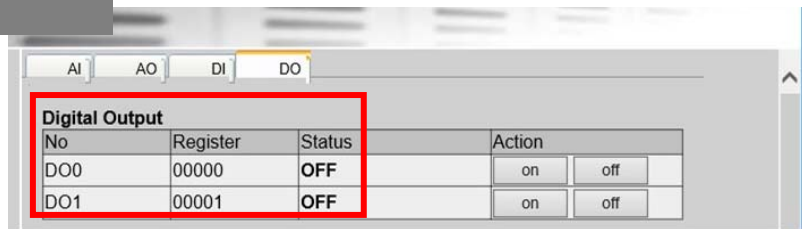

| No  | Register | Status | Action   |
|-----|----------|--------|--|
| DO0 | 00000    | OFF    | <input type="button" value="on"/> <input type="button" value="off"/> |
| DO1 | 00001    | OFF    | <input type="button" value="on"/> <input type="button" value="off"/> |

1

Modify Q13.0, Q13.1 to TRUE and FALSE (ON, OFF)

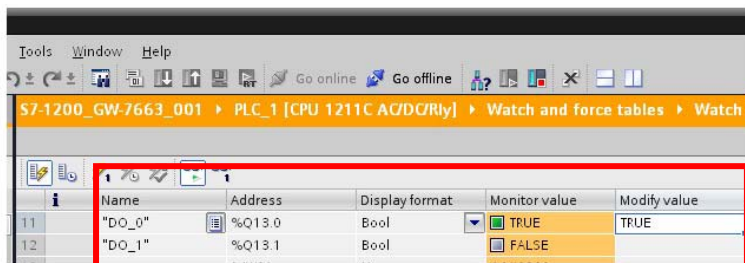

| Name   | Address | Display format | Monitor value                            | Modify value |
|--------|---------|----------------|--|--------------|
| "DO_0" | %Q13.0  | Bool           | <input checked="" type="checkbox"/> TRUE | TRUE         |
| "DO_1" | %Q13.1  | Bool           | <input type="checkbox"/> FALSE           | FALSE        |

2

Get DO status from web server of ET-7026(ON, OFF)

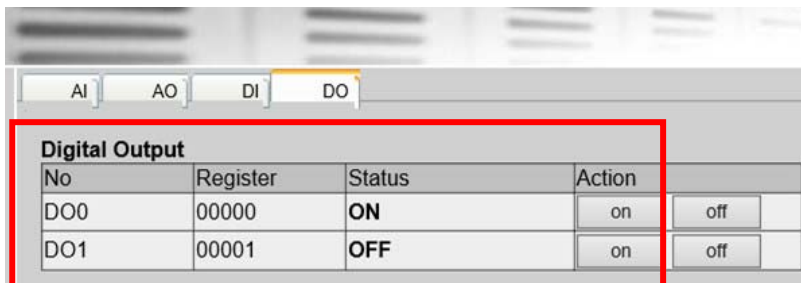

| No  | Register | Status | Action   |
|-----|----------|--------|--|
| DO0 | 00000    | ON     | <input type="button" value="on"/> <input type="button" value="off"/> |
| DO1 | 00001    | OFF    | <input type="button" value="on"/> <input type="button" value="off"/> |

3

## 5. MiniOS7 Utility Tool

---

The MiniOS7 Utility is a useful tool that provides a quick and easy way to get Ethernet settings and firmware version of GW-7663 module.

### 5.1. Installing the MiniOS7 Utility

#### Step 1: Get the MiniOS7 Utility tool

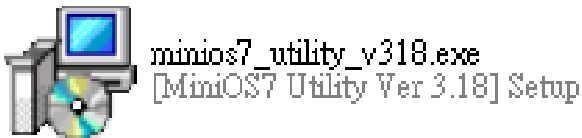

The MiniOS7 Utility can be obtained from companion CD or our FTP site:  
CD:\Napdos\minios7\utility\minios7\_utility\  
[ftp://ftp.icpdas.com/pub/cd/8000cd/napdos/minios7/utility/minios7\\_utility/](ftp://ftp.icpdas.com/pub/cd/8000cd/napdos/minios7/utility/minios7_utility/)

#### Step 2: Follow the prompts to complete the installation

After the installation has been completed, there will be a new short-cut for MiniOS7 Utility on the desktop.

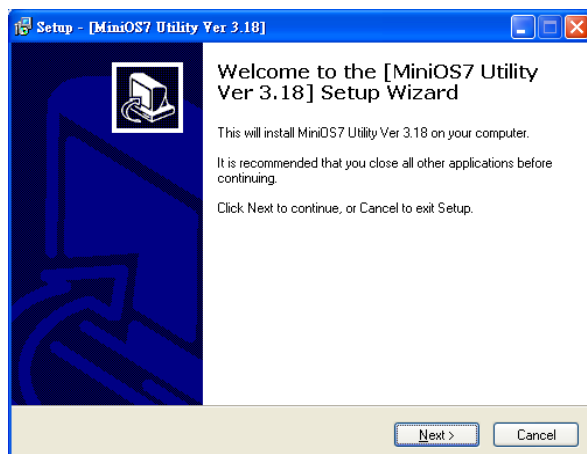

## 5.2. Using MiniOS7 Utility to get Ethernet settings and firmware version

### Step 1: Run the MiniOS7 Utility

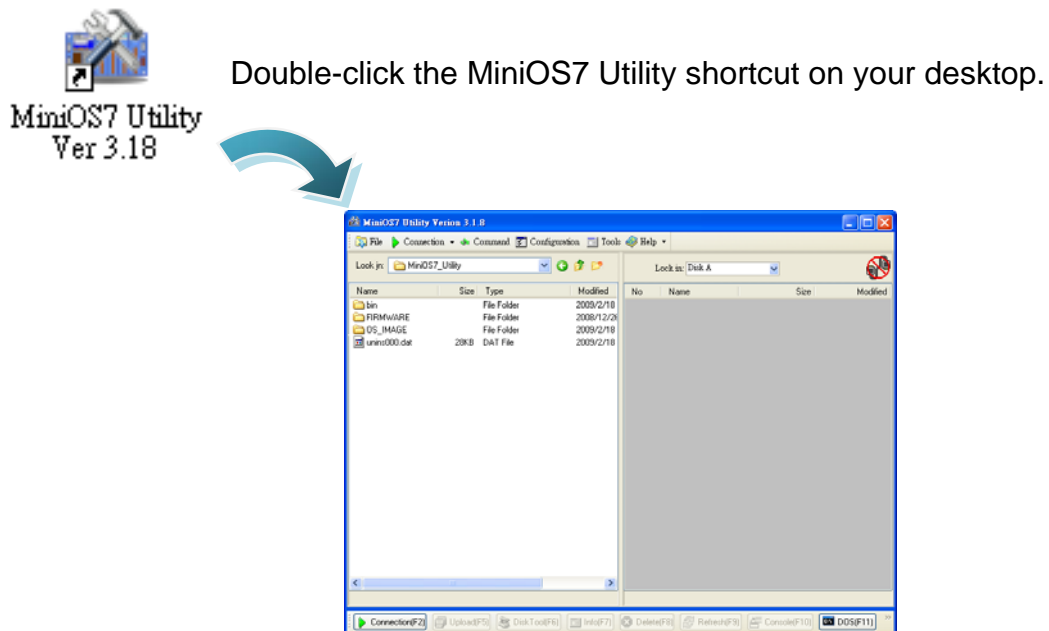

### Step 2: Press “F12” or choose “Search” from the “Connection” menu

After pressing **F12** or choosing **Search** from **Connection** menu, that will search all of the modules that provide by ICP DAS on your network.

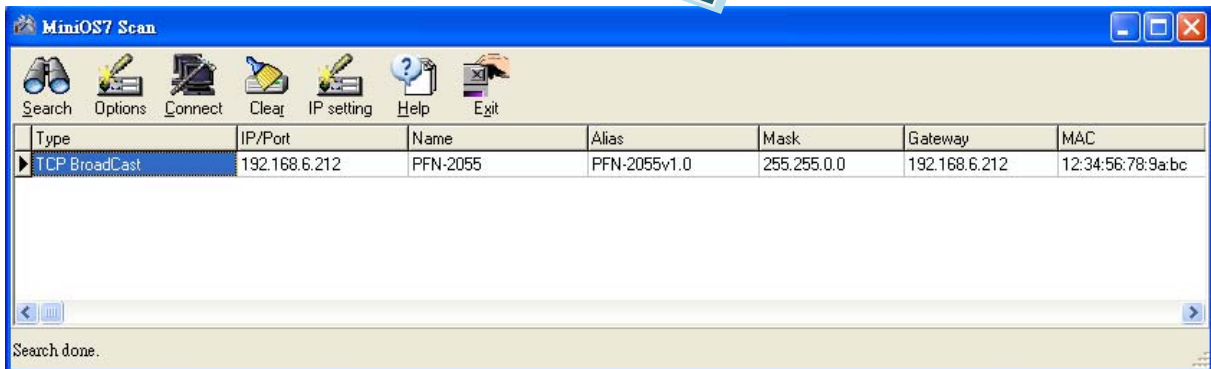
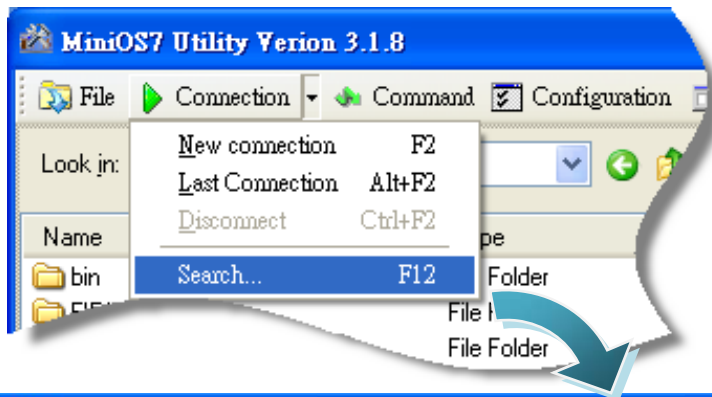

## Tips & Warnings



2. If you can't find the module by searching the network. It means the IP address of GW-7663 module is zero (default IP = 0.0.0.0). At this time, please follow the section 3.2. Network configuration=> Step 3: Set GW-7663 module's name and IP" to set module's IP and then re-search the network again. Or, wait for the PROFINET controller connect to GW-7663 module (AP LED=ON) and then re-search the network again.
3. About scan result of MiniOS7 Utility, Alias=module name & firmware version.

# 6. PFN\_Tool Utility

## 6.1. Installing the PFN\_Tool Utility

### Step 1: Get the PFN\_Tool Utility



The PFN\_Tool Utility can be obtained from companion CD or our FTP site:  
CD:\fieldbus\_cd\profinet\utility\  
[ftp://ftp.icpdas.com.tw/pub/cd/fieldbus\\_cd/profinet/utility/](ftp://ftp.icpdas.com.tw/pub/cd/fieldbus_cd/profinet/utility/)

### Step 2: Follow the prompts to complete the installation

After the installation has been completed, there will be a new shortcut for PFN\_Tool Utility on the desktop.

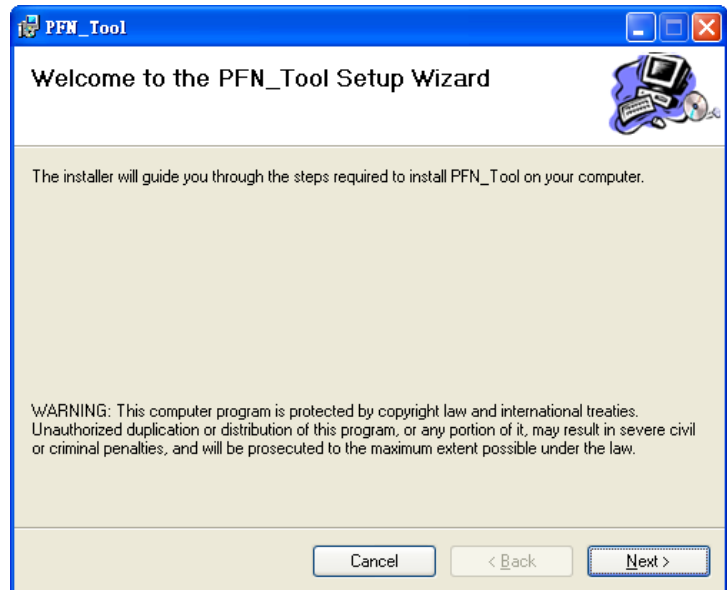

## 6.2. PFN\_Tool Utility Functionalities

### 6.2.1. Module Search

#### Step 1: Select Network Device

Select network device that connect with GW-7663 module, and press “Search Start” button.

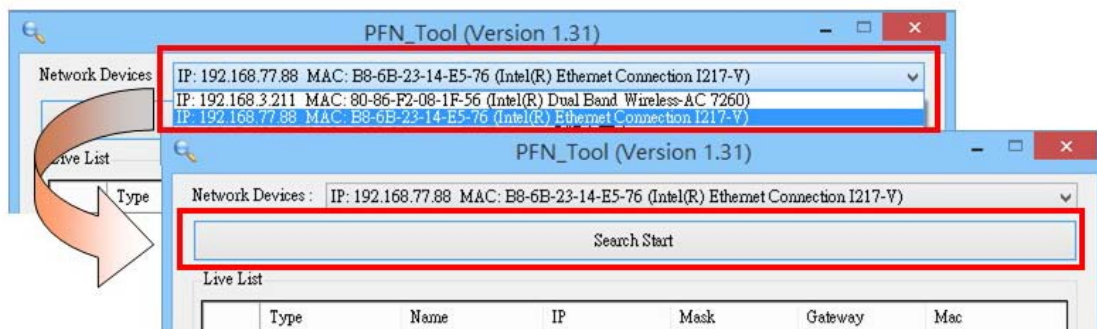

#### Step 2: Search results

Live List will show all of the PROFINET devices on the same network of network device.

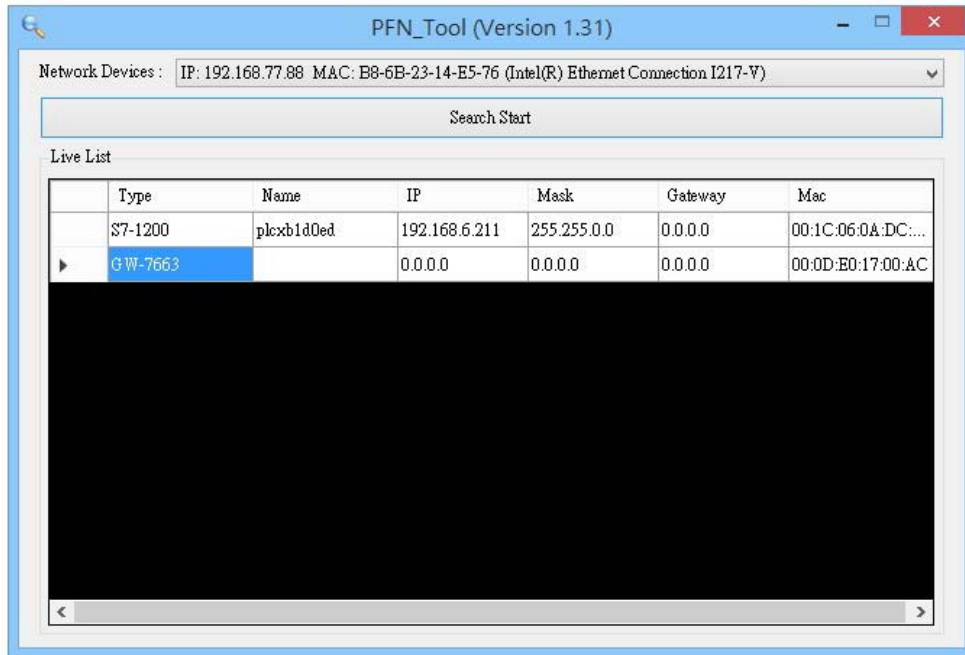



# 6.2.2. Module Basic Configuration

## Step 1: Open Device Basic Configuration

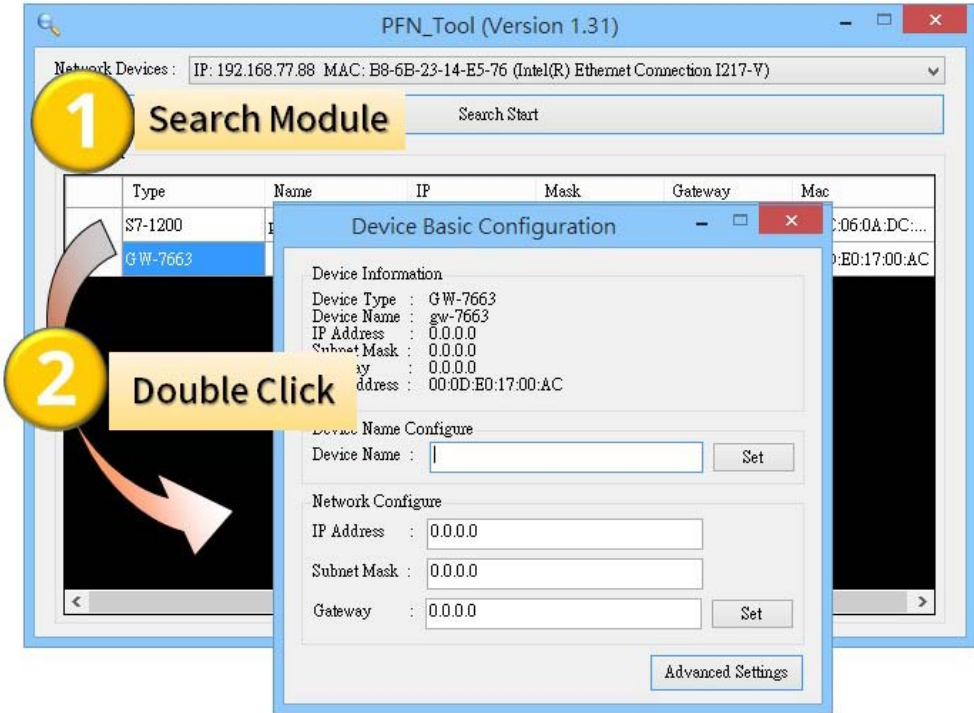

## Step 2: Set Device Name

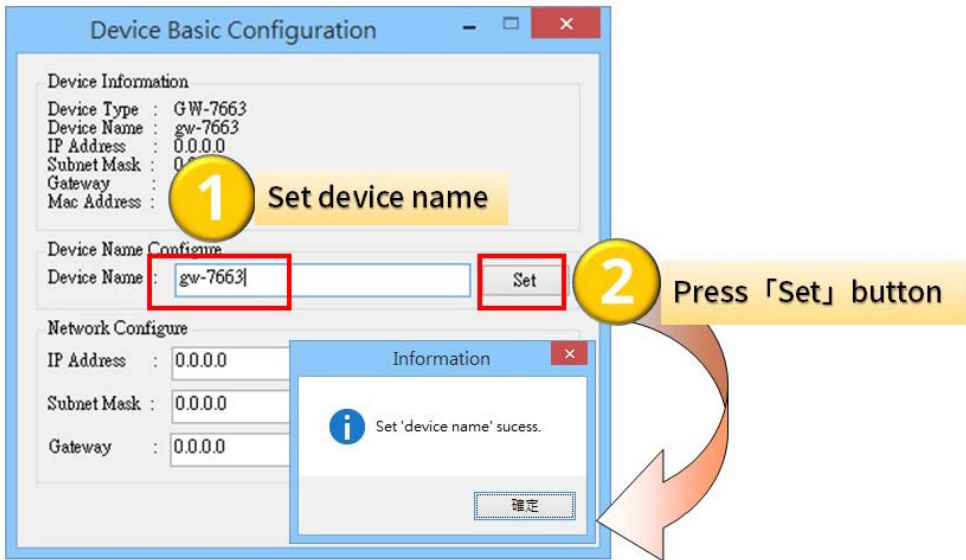

### Step 3: Set Network Parameters

The network parameter of GW-7663 module must have the same domain and different IP with PC.

EX: PC's IP = 192.168.1.110

GW-7663 module's IP = 192.168.1.111

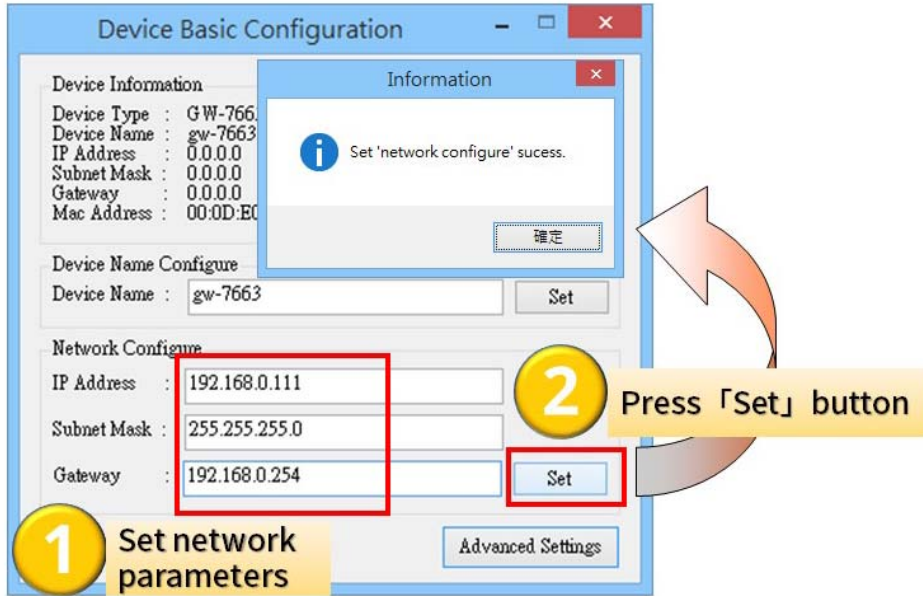

```
Connection-specific DNS Suffix . :  
Description . . . . . : Realtek RTL8168C(P)/8111C(P) PCI-E Gigabit Ethernet NIC  
Physical Address. . . . . : 6C-F0-49-AC-51-8B  
Dhcp Enabled. . . . . : No  
IP Address . . . . . : 192.168.0.110  
Subnet Mask . . . . . : 255.255.255.0  
Default Gateway . . . . . : 192.168.0.254  
DNS Servers . . . . . : 168.95.1.1
```

### Tips & Warnings



1. When PROFINET controller connect to GW-7663 module (AP LED=ON), user can't set device name and network parameters.

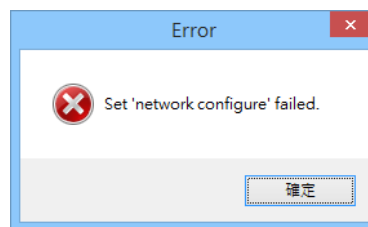
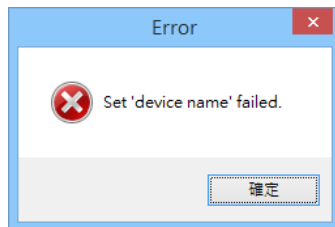

## 6.2.3. Module Advanced Configuration

### Step 1: Open Device Advanced Configuration

The screenshot shows the PFN\_Tool (Version 1.31) interface. On the left, a table lists network devices. The 'GW-7663' device is selected. A yellow callout '1 Search Module' points to the search bar. A yellow callout '2 Double Click' points to the 'GW-7663' entry in the table. A yellow callout '3 Press 'Advanced Settings' button' points to the 'Advanced' button at the bottom of the 'Device Basic Configuration' window. The 'Device Advanced Configuration' window is open, showing various configuration options for the GW-7663 device.

Network Devices: IP: 192.168.77.88 MAC: B8-6B-23-14-E5-76 (Intel(R) Ethernet Connection S7-1200)

| Type    | Name    | IP | Mask | Gatew |
|---------|---------|----|------|-------|
| S7-1200 |         |    |      |       |
|         | GW-7663 |    |      |       |

Device Basic Configuration

Device Information

Device Type : GW-7663  
Device Name : gw-7663  
IP Address : 0.0.0.0  
Mask : 0.0.0.0  
y : 0.0.0.0  
Address : 00:0D:E0:17:00:AC

Name Configure

Device Name : gw-7663

Network Configure

IP Address : 192.168.0.111  
Subnet Mask : 255.255.255.0  
Gateway : 192.168.0.254

Advanced

Device Advanced Configuration

Device Information

Device Type : GW-7663  
Firmware Version : V1.0

Options

Load File Save File Download Settings Upload Settings

Modbus Settings Modbus Test Diagnostic Msg. Communication Log Information

Parameters

Modbus Type: Master(Client) Polling Interval (ms): 500 Server settings: Server NO. 0 OK  
Byte Order: Little Endian(Intel) Query Timeout (ms): 1000 IP: 192 . 168 . 0 . 1  
I/O Safe Mode: Last Value TCP Connect Num: 1 Re-Connect Time (ms): 5000  
Modbus Device ID (dec): 1

Request Command

Function Code: PC1 Read multiple coils status (0x000x) for DO Add  
Server NO. 0 PROFINET Info: Total Input (Byte): 8 Modify  
Modbus ID (dec): 1 (1~247) Total Output (Byte): 8 Delete  
Start Address (dec): 0 (0~65535)  
Count (dec): 1 (1~1024 Bits) System used: 8 Bytes  
 Change Word Order (AABB CCDD -> CCDD AABB)

| Server NO. | ID | FC | Start Addr. | Count | Word order | PFN Input Addr.(Byte) | PFN Output Addr.(Byte) |
|------------|----|----|-------------|-------|------------|-----------------------|------------------------|
|------------|----|----|-------------|-------|------------|-----------------------|------------------------|

Suggested Module : RSW:0 Input:32Byte Output:32Byte

### Step 2: Advanced Configuration

Device Advanced Configuration of GW-7663 has 5 parts, they are (1)Modbus Settings (2)Modbus Test (3)Diagnostic Msg. (4)Communication Log (5)Information

The screenshot shows the 'Device Advanced Configuration' window. The 'Modbus Settings' tab is selected and highlighted with a red box. The other tabs are 'Modbus Test', 'Diagnostic Msg.', 'Communication Log', and 'Information'. The 'Parameters' section is visible below the tabs.

Device Information

Device Type : GW-7663  
Firmware Version : V1.0

Options

Load File Save File Download Settings Upload Settings

Modbus Settings Modbus Test Diagnostic Msg. Communication Log Information

Parameters

## ► Modbus Settings

Configure Modbus devices connected with GW-7663.

### Parameters

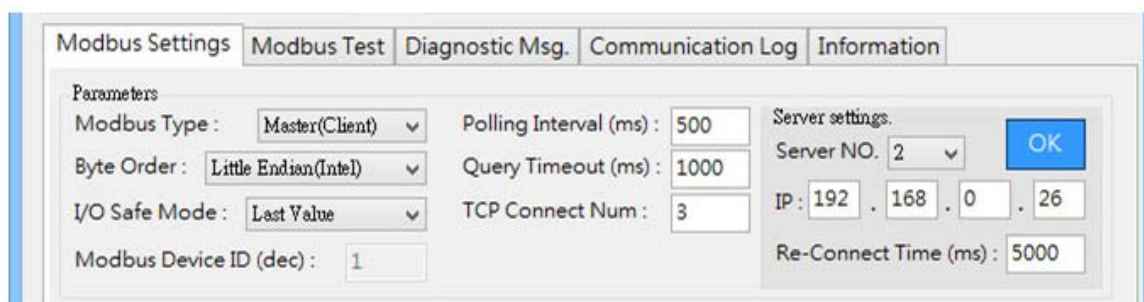

- ※ **I/O Safe Mode**: When GW-7663 acts as a Modbus master device. If connection between GW-7663 and PROFINET IO controller and Modbus slave devices is interrupted.  
“*Last Value*”: Internal DO/DI/AO/AI data retain last value.  
“*Safe Value*”: Internal DO/DI/AO/AI data will be set to safe value and send safe value to PROFINET IO controller and Modbus slave devices.
- ※ **Modbus Device ID**: Modbus address of the GW-7663, when GW-7663 acts as a Modbus slave device.
- ※ **Polling Interval**: Time interval between 2 Modbus commands, when GW-7663 acts as a Modbus master device.
- ※ **TCP Connect Num**: The number of Modbus slave devices connected with GW-7663, when GW-7663 acts as a Modbus master device.
- ※ **Server NO**: Index number of Modbus slave that connected with GW-7663.
- ※ **IP**: The IP address of Modbus slave that connected with GW-7663.
- ※ **Re-Connect Time**: The re-connect time of Modbus slave that connected with GW-7663.
- ※ **Query Timeout**: Timeout value for waiting Modbus response message, when

GW-7663 acts as a Modbus master device.

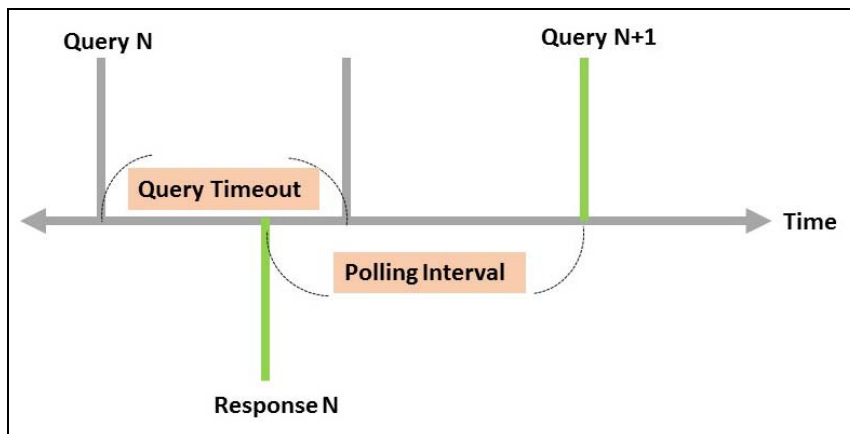

## Options

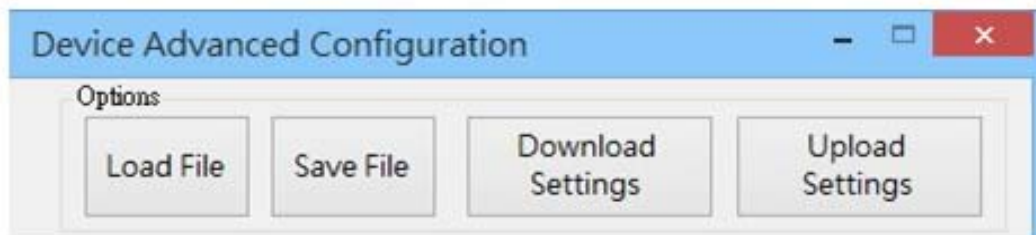

- ※ **Load File**: User can load Modbus settings from a file(\*.ini).
- ※ **Save File**: User can save Modbus settings to a file(\*.ini).
- ※ **Download Settings**: Read Modbus settings from GW-7663.
- ※ **Upload Settings**: Write Modbus settings to GW-7663, GW-7663 will reboot to complete the configuration.

## Request Command – Modbus Master (Client)

Request Command

Function Code : FC16 Write multiple registers (4xxxx) for AO

Modbus ID (dec) : 1 (1~247)

Start Address (dec) : 0 (0~65535)

Count (dec) : 64 (1~64 Words)

Change Word Order (AABB CCDD -> CCDD AABB)

PROFINET Info.

Total Input (Byte) : 512

Total Output (Byte) : 512

System used: 8 Bytes

Add

Modify

Delete

|     | ID | FC       | Start Addr. | Count | Word order | PFN Input Addr.(Byte) | PFN Output Addr.(Byte) |
|-----|----|----------|-------------|-------|------------|-----------------------|------------------------|
| ▶ 1 | 1  | 16 (W&O) | 0           | 64    | No         | N/A                   | 8-135                  |
| 2   | 1  | 16 (W&O) | 64          | 64    | No         | N/A                   | 136-263                |
| 3   | 1  | 16 (W&O) | 128         | 64    | No         | N/A                   | 264-391                |
| 4   | 1  | 16 (W&O) | 192         | 60    | No         | N/A                   | 392-511                |
| 5   | 1  | 4 (RAI)  | 0           | 64    | No         | 8-135                 | N/A                    |
| 6   | 1  | 4 (RAI)  | 64          | 64    | No         | 136-263               | N/A                    |

Suggested Module : RSW:5 Input:512Byte Output:512Byte

- ※ **Max. Modbus command module:** 128 (Module 1~Module 128)
- ※ **Server NO:** Index number of Modbus slave that connected with GW-7663.
- ※ **Function Code:** FC01、FC02、FC03、FC04、FC05、FC06、FC15、FC16
- ※ **Modbus ID:** Device ID of Modbus slave that connected with GW-7663.
- ※ **Start Address:** GW-7663 and Modbus slave device exchange data from this starting address.
- ※ **Count:** It is data size that GW-7663 and Modbus device exchange.
- ※ **Change Word Order:** When checkbox is checked, GW-7663 will change the data between the high word and low word.
- ※ **Suggest Module:** It suggests a PROFINET IO module based on total Modbus command length.



## Request Command – Modbus Slave (Server)

Request Command

Slave Type :

Count (dec) :  (1~4032 Bits)

PROFINET Info.

Total Input (Byte) :

Total Output (Byte) :

System used: 8 Bytes

Change Word Order (AABB CCDD -> CCDD AABB)

|     | Server NO. | ID | FC | Mapping Table | Count | Word order | PFN Input Addr.(Byte) | PFN Output Addr.(Byte) |
|-----|------------|----|----|---------------|-------|------------|-----------------------|------------------------|
| ▶ 1 | N/A        | 1  | DI | 10001~10008   | 8     | No         | N/A                   | 8~8                    |
| 2   | N/A        | 1  | AI | 30001~30002   | 2     | No         | N/A                   | 9~12                   |
| 3   | N/A        | 1  | DO | 00001~00008   | 8     | No         | 8~8                   | N/A                    |
| 4   | N/A        | 1  | AO | 40001~40004   | 4     | No         | 9~16                  | N/A                    |

Suggested Module : RSW:0 Input:32Byte Output:32Byte

- ※ **Slave Type**: Modbus IO type when GW-7663 act as a Modbus slave.
- ※ **Count**: It is data size that GW-7663 and Modbus device exchange.
- ※ **Change Word Order**: When checkbox is checked, GW-7663 will change the data between the high word and low word.
- ※ **Suggest Module**: It suggests a PROFINET IO module based on total Modbus command length.



## ► Modbus Test

User can test communication between GW-7663 and Modbus devices.

**1. Configure Modbus Settings**

**2. Move to Modbus Test page and press 「Upload Settings」 button**

**3. Press 「Send Data」 to change output value**

**4. It will auto update input value**

**1. Set output value**

| Server NO. | ID | FC | Start Addr. | Count | Word order | FFN Input Addr. (Byte) | FFN Output Addr. (Byte) |
|------------|----|----|-------------|-------|------------|------------------------|-------------------------|
| 1          | 0  | 1  | 4 (RAI)     | 0     | 6          | No                     | 8-19                    |
| 2          | 0  | 1  | 16 (WAO)    | 0     | 2          | No                     | N/A                     |
| 3          | 0  | 1  | 2 (RDI)     | 0     | 2          | No                     | 20-20                   |
| 4          | 0  | 1  | 15 (WDO)    | 0     | 2          | No                     | N/A                     |

| Word   | Value (Hex) |
|--------|-------------|
| Word 1 | 0002        |
| Word 2 | FFFF        |

| Server NO. | ID | FC | Start Addr. | Count | Word order | FFN Input Addr. (Byte) | FFN Output Addr. (Byte) |
|------------|----|----|-------------|-------|------------|------------------------|-------------------------|
| 1          | 0  | 1  | 4 (RAI)     | 0     | 6          | No                     | 8-19                    |
| 2          | 0  | 1  | 16 (WAO)    | 0     | 2          | No                     | N/A                     |
| 3          | 0  | 1  | 2 (RDI)     | 0     | 2          | No                     | 20-20                   |
| 4          | 0  | 1  | 15 (WDO)    | 0     | 2          | No                     | N/A                     |

| Word   | Value (Hex) |
|--------|-------------|
| Word 1 | 0002        |
| Word 2 | FFFF        |
| Word 3 | FFFF        |
| Word 4 | FFFF        |
| Word 5 | FFFF        |

## ► Diagnostic Msg.

It shows diagnostic messages of GW-7663.

**1** Press 「Update」 button to update diag. msg

**2** Diag. Msg. Count : 1

**2** Diag. Msgs.

| Diag Data | Type           | Message                  |
|-----------|----------------|--------------------------|
| 0x01 0x0C | Module 1 Error | Response Message Timeout |

**3**

| Name | Address   | Display format | Monitor value | Modify value | Comment |
|------|-----------|----------------|---------------|--------------|---------|
| 1    | %B1       | Hex            | 16#01         |              |         |
| 2    | %B2       | Hex            | 16#01         |              |         |
| 3    | %B3       | Hex            | 16#0C         |              |         |
| 4    | <Add new> |                |               |              |         |

## ► Communication Log

It shows communication logs between GW-7663 and Modbus devices connected with GW-7663.

**1**

Press 「Update」 button to update log

**2**

Update OK

| #  | Timestamp(ms) | Type | Tx/Rx | Frame   |
|----|---------------|------|-------|---|
| 1  | 87760         | RAI  | Tx    | 01 02 00 00 00 06 01 04 00 00 00 06                         |
| 2  | 87765         | RAI  | Rx    | 01 02 00 00 00 0F 01 04 0C 00 02 FF FF FE FF FF FF FF FF FF |
| 3  | 88270         | WAO  | Tx    | 01 02 00 00 00 0B 01 10 00 00 02 04 00 00 00 00             |
| 4  | 88275         | WAO  | Rx    | 01 02 00 00 00 06 01 10 00 00 00 02                         |
| 5  | 88780         | EDI  | Tx    | 01 02 00 00 00 06 01 02 00 00 02                            |
| 6  | 88785         | EDI  | Rx    | 01 02 00 00 00 04 01 02 01 02                               |
| 7  | 89290         | WDO  | Tx    | 01 02 00 00 00 08 01 0F 00 00 00 02 01 00                   |
| 8  | 89295         | WDO  | Rx    | 01 02 00 00 00 06 01 0F 00 00 00 02                         |
| 9  | 89801         | RAI  | Tx    | 01 02 00 00 00 06 01 04 00 00 00 06                         |
| 10 | 89805         | RAI  | Rx    | 01 02 00 00 00 0F 01 04 0C 00 02 FF FF FF FF FF FF FF FF    |
| 11 | 90310         | WAO  | Tx    | 01 02 00 00 00 0B 01 10 00 00 02 04 00 00 00 00             |
| 12 | 90315         | WAO  | Rx    | 01 02 00 00 00 06 01 10 00 00 00 02                         |
| 13 | 90820         | EDI  | Tx    | 01 02 00 00 00 06 01 02 00 00 02                            |
| 14 | 90825         | EDI  | Rx    | 01 02 00 00 00 04 01 02 01 02                               |
| 15 | 91330         | WDO  | Tx    | 01 02 00 00 00 08 01 0F 00 00 00 02 01 00                   |
| 16 | 91335         | WDO  | Rx    | 01 02 00 00 00 06 01 0F 00 00 00 02                         |
| 17 | 91840         | RAI  | Tx    | 01 02 00 00 00 06 01 04 00 00 00 06                         |
| 18 | 91845         | RAI  | Rx    | 01 02 00 00 00 0F 01 04 0C 00 02 FF FF FF FF FF FF FF FF    |
| 19 | 92350         | WAO  | Tx    | 01 02 00 00 00 0B 01 10 00 00 02 04 00 00 00 00             |
| 20 | 92355         | WAO  | Rx    | 01 02 00 00 00 06 01 10 00 00 00 02                         |
| 21 | 92860         | EDI  | Tx    | 01 02 00 00 00 06 01 02 00 00 02                            |
| 22 | 92865         | EDI  | Rx    | 01 02 00 00 00 04 01 02 01 02                               |
| 23 | 93370         | WDO  | Tx    | 01 02 00 00 00 08 01 0F 00 00 00 02 01 00                   |
| 24 | 93375         | WDO  | Rx    | 01 02 00 00 00 06 01 0F 00 00 00 02                         |
| 25 | 93880         | RAI  | Tx    | 01 02 00 00 00 06 01 04 00 00 00 06                         |
| 26 | 93885         | RAI  | Rx    | 01 02 00 00 00 0F 01 04 0C 00 02 FF FF FF FF FF FF FF FF    |
| 27 | 94390         | WAO  | Tx    | 01 02 00 00 00 0B 01 10 00 00 02 04 00 00 00 00             |
| 28 | 94395         | WAO  | Rx    | 01 02 00 00 00 06 01 10 00 00 00 02                         |

**3**

1. Press 「Save」 button to Save logs

2. Save ok

► Information

It shows PROFINET settings of GW-7663.

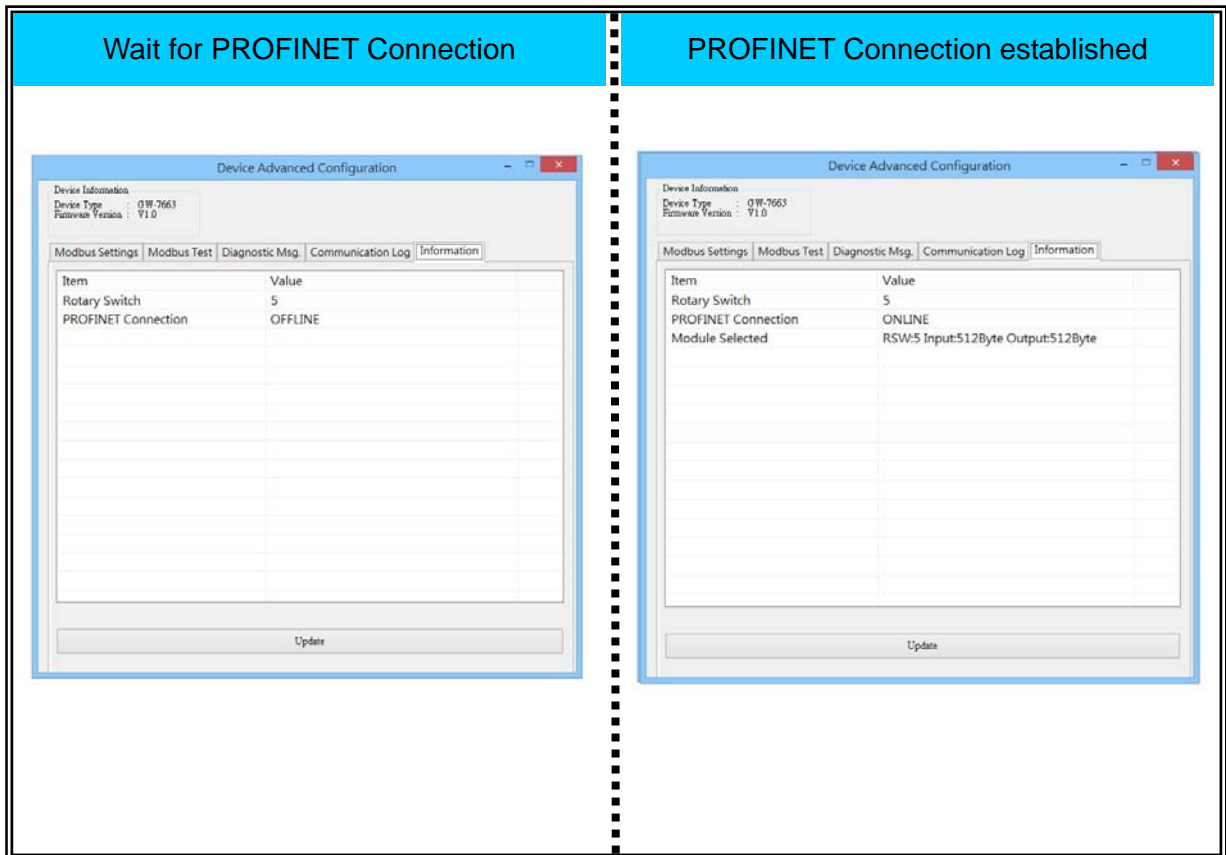

## 7. Troubleshooting

| Item | Trouble state   | Solution  |
|------|---|---|
| 1    | 'AP', 'BOOT' and 'ERR' LED are always off.  | The power supply of GW-7663 module has some problems. Please check the wire connection of the power and the voltage is between 10~30V <sub>DC</sub> .   |
| 2    | 'AP' and 'BOOT' LED are always off and 'ERR' LED is always flash per 500ms.                 | That means the GW-7663 module can't connect to the PROFINET IO controller. Please check the wire connection and module configuration (include network settings, device name) and project configuration of engineering tool that provide by PROFINET IO controller's manufacturer.   |
| 3    | 'AP' LED is always on and 'BOOT' LED is always off and 'ERR' LED is always flash per 500ms. | It means that the value of rotary switch does not match the settings of the modules (please refer to section 4.2. Module configuration).  |
| 4    | 'BOOT' LED is always on.  | It means the GW-7663 module is at Bootloader mode. Please switch to AP mode(section 1.4. Overview→Rotary Switch).   |
| 5    | Can't find any GW-7663 module by MiniOS7 Utility  | It means the IP address of GW-7663 module is zero (default IP = 0.0.0.0). At this time, please follow the section 3.2. Network configuration => Step 3: Set GW-7663 module's name and IP" to set module's IP and then re-search the network again. Or, wait for the PROFINET controller connect to GW-7663 module (AP LED=ON) and then re-search the network again. |
| 6    | Can't find any GW-7663 module by PFN_Tool Utility   | <ol style="list-style-type: none"> <li>Please check the wire connection</li> <li>Please set the GW-7663 module to AP mode, please refer to the section1.4. Overview. Please check network card is ok, and GW-7663 module and network card have to in the same network.</li> </ol>   |

# 8. Appendix

---

## 8.1. Modbus Exception Code

| Code | Name                         | Meaning   |
|------|------------------------------|---|
| 01   | Illegal Function             | The Function Code received in the query is not an allowable action for the server (or slave). This may be because the function code is only applicable to newer devices, and was not implemented in the unit selected. It could also indicate that the server (or slave) is in the wrong state to process a request of this type, for example because it is not configured and is being asked to return register values.  |
| 02   | Illegal Data Address         | The data address received in the query is not an allowable address for the server (or slave). More specifically, the combination of reference number and transfer length is invalid. For a controller with 100 registers a request of offset 96 and a length of 5 will generate exception 02.   |
| 03   | Illegal Data Value           | A value contained in the query data field is not an allowable value for server (or slave). This indicates a fault in the structure of the remainder of a complex request, such as that the implied length is incorrect. It specifically does NOT mean that a data item submitted for storage in a register has a value outside the expectation of the application program, since the MODBUS protocol is unaware of the significance of any particular value of any particular register. |
| 04   | Failure In Associated Device | An unrecoverable error occurred while the server (or slave) was attempting to perform the requested action.   |
| 05   | Acknowledge                  | Specialized use in conjunction with programming commands. The server (or slave) has accepted the request and is processing it, but a long duration of time will be required to do so. This response is returned to prevent a timeout error from occurring in the client (or master). The client (or master) can next issue a Poll Program Complete message to determine if processing is completed.   |

|    |   |   |
|----|---|---|
| 06 | Busy, Rejected Message                  | Specialized use in conjunction with programming commands. The server (or slave) is engaged in processing a long-duration program command. The client (or master) should retransmit the message later when the server (or slave) is free.  |
| 07 | Negative Acknowledgement                | The program function just requested cannot be performed. Issue poll to obtain detailed device dependent error information. Valid for Program/Poll 13 and 14 only.   |
| 08 | Memory Parity Error                     | Specialized use in conjunction with function codes 20 and 21 and reference type 6, to indicate that the extended file area failed to pass a consistency check. The server (or slave) attempted to read record file, but detected a parity error in the memory. The client (or master) can retry the request, but service may be required on the server (or slave) device. |
| 0A | Gateway Path Unavailable                | Specialized use in conjunction with gateways, indicates that the gateway was unable to allocate an internal communication path from the input port to the output port for processing the request. Usually means that the gateway is misconfigured or overloaded.  |
| 0B | Gateway Target Device Failed to respond | Specialized use in conjunction with gateways, indicates that no response was obtained from the target device. Usually means that the device is not present on the network.  |