













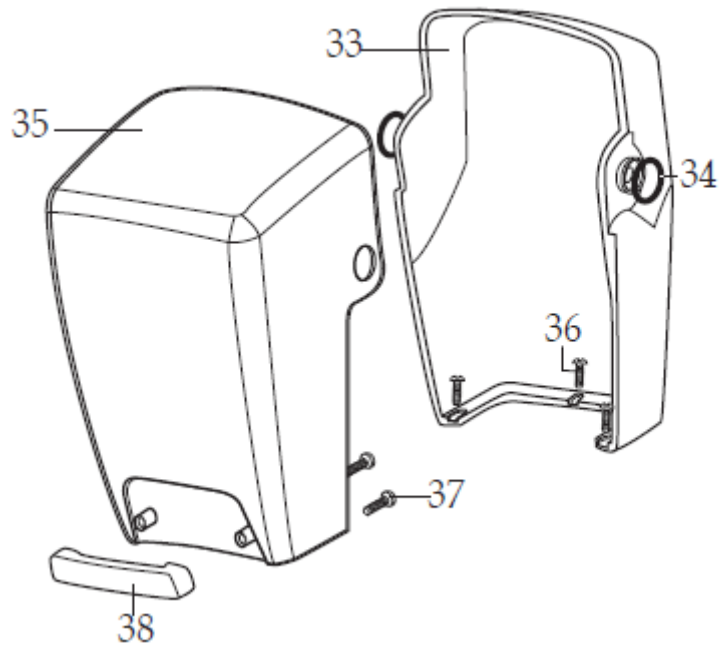

Machine	Explode	Code	Description
Waring Xtreme Hi-Power Blender MX1100	1		Jar Lid Cover
Waring Xtreme Hi-Power Blender MX1100	2		Jar Lid
Waring Xtreme Hi-Power Blender MX1100	3		Jar Only (64oz Stackable)
Waring Xtreme Hi-Power Blender MX1100	3	DM876	Jar With Blending Assembly (64oz Stackable)
Waring Xtreme Hi-Power Blender MX1100	3	AF918	Jar With Blending Assembly (48oz Stackable)
Waring Xtreme Hi-Power Blender MX1100	4		Blade Assembly
Waring Xtreme Hi-Power Blender MX1100	5		Bearing Holder O Ring
Waring Xtreme Hi-Power Blender MX1100	6		Nut Gasket
Waring Xtreme Hi-Power Blender MX1100	7		Bearing Holder Nut
Waring Xtreme Hi-Power Blender MX1100	8		Drive Coupling
Waring Xtreme Hi-Power Blender MX1100	9		Jar Pad
Waring Xtreme Hi-Power Blender MX1100	10		Jar Pad For Sound Enclosure
Waring Xtreme Hi-Power Blender MX1100	11		Motor
Waring Xtreme Hi-Power Blender MX1100	12		Dampening Plate Gasket
Waring Xtreme Hi-Power Blender MX1100	13		Top Housing With Ferrite Core & Cord
Waring Xtreme Hi-Power Blender MX1100	13		Top Housing-Black (Older Unit)
Waring Xtreme Hi-Power Blender MX1100	14		Motor Foam
Waring Xtreme Hi-Power Blender MX1100	15		Dampening Plate Bushing
Waring Xtreme Hi-Power Blender MX1100	16		Dampening Plate Sleeve
Waring Xtreme Hi-Power Blender MX1100	17		Washer
Waring Xtreme Hi-Power Blender MX1100	18		Screw
Waring Xtreme Hi-Power Blender MX1100	19		Soft Start Control Panel
Waring Xtreme Hi-Power Blender MX1100	20		Housing Foam Baffle-Rear
Waring Xtreme Hi-Power Blender MX1100	21		Housing Foam Baffle-Front
Waring Xtreme Hi-Power Blender MX1100	22		Motor Housing
Waring Xtreme Hi-Power Blender MX1100	23		Washer
Waring Xtreme Hi-Power Blender MX1100	24		Bottom Housing Foam Baffle
Waring Xtreme Hi-Power Blender MX1100	25		Foam Baffle
Waring Xtreme Hi-Power Blender MX1100	26		Cable Tie
Waring Xtreme Hi-Power Blender MX1100	27		Top Housing With Ferrite Core & Cord
Waring Xtreme Hi-Power Blender MX1100	27		Power Cord Set
Waring Xtreme Hi-Power Blender MX1100	28		Strain Relief
Waring Xtreme Hi-Power Blender MX1100	29		Bottom Housing-Black
Waring Xtreme Hi-Power Blender MX1100	30		Screw
Waring Xtreme Hi-Power Blender MX1100	31		Corner Post
Waring Xtreme Hi-Power Blender MX1100	32		Screw



Machine	Explode	Code	Description
Waring Xtreme Hi-Power Blender MX1100	33		Inner Sound Enclosure
Waring Xtreme Hi-Power Blender MX1100	34		O Ring
Waring Xtreme Hi-Power Blender MX1100	35		Outer Sound Enclosure
Waring Xtreme Hi-Power Blender MX1100	36		Screw
Waring Xtreme Hi-Power Blender MX1100	37		Screw
Waring Xtreme Hi-Power Blender MX1100	38		Sound Enclosure Handle