

# TMF / SKFT-N ActiveCore

SKOPE Top Mount Freezer  
Hydrocarbon



TMF / SKFT-N ActiveCore  
SKOPE Top Mount Freezer  
Hydrocarbon  
Service Manual

MAN80227  
Rev. 1.3 Aug. 2022

© 2021 SKOPE Industries Limited. All rights reserved.

SKOPE Industries Limited reserves the right to alter specifications without notice.

**SKOPE**® is a registered trademark of SKOPE Industries Limited.  
SKOPE INDUSTRIES LIMITED

Head Office  
PO Box 1091, Christchurch  
New Zealand  
A.B.N. 73 374 418 306  
AU: 1800 121 535  
NZ: 0800 947 5673  
E-mail: [skope@skope.com](mailto:skope@skope.com)  
Website: [www.skope.com](http://www.skope.com)

### **Trademark Infringement**

The SKOPE trademark on this product is infringed if the owner, for the time being, does any of the following:

- Applies the trade mark to the product after its state, condition, get-up or packaging has been altered in any manner
- Alters, removes (including part removal) or obliterates (including part obliteration) the trade mark on the product
- Applies any other trade mark to the product
- Adds to the product any written material that is likely to damage the reputation of the trade mark

Notice of the above contractual obligations passes to:

- Successors or assignees of the buyer
- Future owners of the product

# CONTENTS

---

<b>1 Servicing Hydrocarbon</b>	
Overview	5
SKOPE HC Service Requirements	6
<b>2 Specifications</b>	
Models	7
<b>3 Electronic Controller</b>	
Overview	8
Apps	8
SCS Connect Field App	8
SCS Connect Track App	8
SKOPE- connect App	8
Controller Faceplate	9
Buttons and Display	9
Service Mode	9
SCS Connect Field App and Track App	11
Connecting	11
App Categories	12
Faults and Alarms	13
<b>4 Wiring</b>	
Model: TMF/SKFT650N/1000N	16
<b>5 Spare Parts</b>	
Main Assembly - TMF/SKFT650N Series	20
Main Assembly - TMF/SKFT1000N Series	21
Cabinet Assembly - TMF650N Series	22
Cabinet Assembly - TMF1000N Series	23
Glass Door Assembly	24
Sign Assembly	25
Unit Assembly UTHDNI-0043	26
Electronic Controller Assembly	28
Unit Junction Box Assembly	29
<b>6 Installation</b>	
Installation Guidelines	30
Ventilation Requirements	31
Door Handles	32
Fitting Door Handles	32
Removing Door Handles	33
Shelves	34
Shelf Clips	34
Repositioning Shelves	34
<b>7 Operation</b>	
Loading Product	35
Light Switch	35
Cabinet Heat Control	36
Overview	36
Dew Point Sensor	36
Temp Sensor	36
Trouble Shooting	37
Adjusting Heater Power	38
Procedure	38

Hot Gas Defrost . . . . .	39
Refrigeration System Diagnostics – Function Test . . . . .	40
Refrigeration System Table . . . . .	41
Compressor and Inverter Information . . . . .	42
Inverter LED Indication . . . . .	42
Trouble Shooting . . . . .	42
Compressor . . . . .	43
Compressor Inverter . . . . .	44
<b>8 Replacement Procedures</b>	
Lighting . . . . .	45
Sign Light . . . . .	48
Doors . . . . .	49
Alignment Adjustment . . . . .	49
Height Adjustment . . . . .	49
Replacing the Gasket . . . . .	49
Removing and Refitting the Door . . . . .	49
Adjusting Door Tension . . . . .	51
Replacing the Torsion Bar . . . . .	51
Refrigeration Unit . . . . .	52
Before Servicing . . . . .	52
Refrigeration Unit Assembly . . . . .	53
Gas Detector . . . . .	53
Leak Detector . . . . .	53
On-Site Work . . . . .	53
Not Cooling Fault . . . . .	54
Hydrocarbon Workshop . . . . .	54
Removing the Unit . . . . .	55
Replacing the Unit . . . . .	56
Unit Electrics Box Assembly . . . . .	57
Unit Cover . . . . .	58
Condenser Fan . . . . .	58
Evaporator Fan . . . . .	60
Replacing the Controller . . . . .	62
Door Switch . . . . .	63
Control Probe . . . . .	63
Evaporator Probe . . . . .	64
Condenser Probe . . . . .	65
Ambient Probe . . . . .	66
Replacing Component Notes . . . . .	67
Cleaning . . . . .	68
Cabinet . . . . .	68
Condenser Coil . . . . .	68
Probe Resistance . . . . .	69
<b>9 Troubleshooting</b>	
Electronic Controller . . . . .	71
Cabinet and Refrigeration Unit . . . . .	71
On-site work procedure by authorised service person . . . . .	73



# 1 Servicing Hydrocarbon

---

## Overview

---

---

This ActiveCore freezer range uses hydrocarbon (HC) R290 as its refrigerant. R290 is a natural refrigerant that has a very low environmental impact.

Special service requirements are needed as R290 is a flammable refrigerant.

### Safety hazards

The main hydrocarbon safety hazards are:



- Flammability
- Venting of hydrocarbon and compressor oil
- Asphyxiation

Do not interfere with the refrigeration system. All refrigeration maintenance and repairs must be undertaken according to the SKOPE HC Service Requirements below.

See “SKOPE HC Service Requirements” on page 6 for more information including examples of hazardous activities.

### Electrical safety precautions

Correct wiring routing is as important as using the correct components for compliance with safety and radio interference regulations. In order to maintain safety and compliance with regulations, any wiring that is disturbed during servicing must be replaced and secured in its original position.

## SKOPE HC Service Requirements

---

Servicing must only be performed by Approved SKOPE Service Technicians, and must meet all requirements in the SKOPE HC Service Policy (available from SKOPE), including the following:

### **Hydrocarbon work – SKOPE Service Policy**

**It is the responsibility of the service technician to follow SKOPE's Hydrocarbon equipment service policy and by accepting a service work order they agree to the following (where applicable):**

- MUST – Ensure all workers are trained in the SAFETY of hydrocarbon products to the appropriate level for the work required.
- MUST – Follow all Local Safety Regulations relevant to flammable refrigerant gases.
  - Australia should reference - AIRAH Flammable Refrigerants – Safety Guide
  - New Zealand should reference – Flammable Refrigerant Safety Documentation (Refrigerant License NZ)
- MUST – Adhere to all on-site (workplace) Health and Safety requirements
- MUST – Not modify or alter the design of SKOPE equipment in any way
- MUST – In cases where the refrigeration system is not readily removable from the cabinet; then the entire cabinet MUST be sent to the Hydrocarbon workshop for repair.
- MUST – ONLY use SKOPE OEM Spare Parts; or identical replacement parts. Any variation in replacement part may render the system non-compliant and unsafe.
- MUST – Follow all best practice work activities for servicing hydrocarbon refrigerants (SKOPE recommend attending specific hydrocarbon refrigeration handling training courses). Nitrogen must be used for purging system before commencing “Hot Work” – brazing.
- MUST – Adhere to relevant SKOPE Service Manual. If any contradiction, the local Regulations take precedence over SKOPE requirements
- MUST – Work only in suitable, safe and compliant work spaces. Personal Protective Equipment must always be used when working on Hydrocarbon equipment.
- MUST – Service people diagnosing refrigeration faults must always carry and utilise Flammable Gas detectors when working on Hydrocarbon equipment.
- MUST – Prior to any service work; know where and how to safely and quickly isolate power supply to cabinet
- MUST – Not perform any Hot Work (brazing etc.) in the field. These are to be completed in a suitable service depot / workshop (in a dedicated specific Hazardous Work Area compliant to local flammable gas regulations)
- MUST – Not transport a refrigeration system with a known active leak. If there is an active leak the refrigerant must be safely removed (with use of Bullet Piercing Valve or Line Tap valves) before transporting. Valves must be removed at the hydrocarbon service depot once repair is completed.
- MUST – All hydrocarbon workshop areas must have emergency plans; that includes suitable evacuation and fire control plans and equipment.
- MUST – Only use refrigerant grade hydrocarbon, to precise mass specified on removable refrigeration system serial label.
- MUST – Be accurate refrigerant charge; The refrigerant mass is ultra-low charge and must only be measured in by accurate scales to +/- 1.0gram. Refrigerant MUST not be overcharged; or added to an already charged system.
- MUST – Use identical drier replacement; as any change will affect gas charge volume; and effect reliability compliance and safety.
- MUST – Any pipework replacement, must be identical to genuine SKOPE parts.
- MUST – Not introduce a sparking device inside a cabinet or inside a removable refrigeration system. Battery drills should not be used.
- MUST – Not perform any activity that could stress a refrigeration pipe (unless in a workshop).
- MUST – Get customer authorisation to permanently swap a removable refrigeration system.
- MUST – Have the Wellington Drive SCS Field app installed on a Bluetooth enabled device carried by the service technician (exception is for cabinets that do not utilise the Wellington Drive Controller). The app should be utilised for safe, accurate diagnosis of the system and it is required to complete a controller replacement in the field.
- RECOMMENDED – Have the Wellington Drive SCS Track app installed on a Bluetooth enabled device carried by the service technician. This passive app collects system data from the Wellington Drive SCS Connect Controller and transmit it to the cloud.
- Logistics companies may be used to transport a complete refrigerator where no separation of the refrigeration system occurs. Logistics companies are not required to be contracted to this SKOPE Service Policy.

## 2 Specifications

### Models

This freezer service manual is applicable to the SKOPE TMF ActiveCore top mount freezers detailed in the table below. Refer to the relevant product specification sheet (available on the SKOPE website: [www.skope.com](http://www.skope.com)) for specifications.

Series	Model	SKOPE ID	Unit
TMF650N ActiveCore	TMF650N-A	LTH65GYN	UTHDNI-0043
	TMF650N-AC	LTH65BYN	
TMF1000N ActiveCore	TMF1000N-A	LHT10GYN	
	TMF1000N-AC	LTH10BYN	
SKFT650N ActiveCore	SKFT650N-A	LT65GYN	
	SKFT650N-AC	LT65BYN	
SKFT1000N ActiveCore	SKFT1000N-A	LT10GYN	
	SKFT1000N-AC	LT10BYN	

## 3 Electronic Controller

---

### Overview

---

---

The freezer is fitted with a Wellington Drive SCS Connect electronic controller. The controller is located above the door/s and visible from the outside of the freezer.

Controller servicing can be performed via the controller faceplate, or the SCS Connect Field app.

This does not control the cabinet body and door heater elements

### Apps

---

---

**SCS Connect Field App** The SCS Connect Field app is designed for service techs, and provides access to the controller from mobile devices with Bluetooth capability. The app provides information on data logging, alarm notification and diagnostic control.

See “SCS Connect Field App and Track App” on page 11 for information on setting up and using the app.

**SCS Connect Track App** The SCS Connect Track app is used to upload data from freezers fitted with a Wellington SCS Connect electronic controller.

**SKOPE-connect App** The SKOPE-connect app is designed for end-users and provides wireless access to the controller from mobile devices with Bluetooth capability.

The app allows end users to adjust some electronic controller settings including energy saving modes, open/close hours and preset temperature set points for specific product.

The app may be useful for diagnostics. Download from the Google Play Store, or Apple App Store.



## Controller Faceplate

**Buttons and Display** The controller faceplate includes the front display panel and interface buttons.

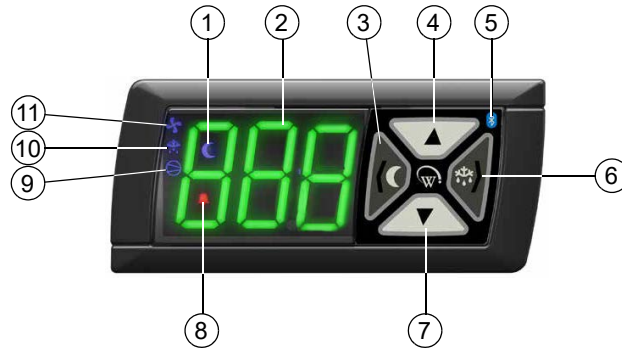

No.	Description
1	<b>Night Mode:</b> Indicator. On during cooler night mode.
2	<b>Display:</b> Indicator. Digital display of cabinet air temperature or messages. The temperature is what the sensor inside the cooler detects, and not necessarily the product temperature. However, they may be very close depending on how the controller is set to sense temperature.
3	<b>Light Switch - Night Mode (back/abort):</b> Button. Press to switch the lights on or off. Press and hold to switch cooler between day and night mode. Used during programming.
4	<b>Up:</b> Button. Used for programming.
5	<b>Bluetooth:</b> Indicator. Flashing when connected to a device.
6	<b>Defrost Cycle (next/enter):</b> Button. Press and hold to initiate manual defrost. Used during programming.
7	<b>Down:</b> Button. Used for programming.
8	<b>Fault - Alarm:</b> Indicator. On during fault or alarm. Note: Alarm message is also shown on the display during alarm.
9	<b>Compressor:</b> Indicator. On when the compressor is running.
10	<b>Defrost Mode:</b> Indicator. On during defrost cycle.
11	<b>Fan:</b> Indicator. ON when evaporator fan running.

**Service Mode** Service mode can be accessed and used via the SCS Connect Field app (see “SCS Connect Field App and Track App” on page 11), or the controller faceplate (see below).

**Note:** A 9 digit pin code is required to access service mode via the controller buttons. Contact your User Manager to receive your activation code.

### To enable and use service mode via the controller faceplate

1. Press and hold the up and down buttons simultaneously until prompted to enter the 9 digit pin code.
2. Enter service mode pin code.
3. Use the up, down, back/abort and next/enter buttons to navigate to the desired category.

There are 5 main service mode categories when accessing and using service mode via the controller faceplate:

**Parameters**

Provides access and editing of individual controller parameters.

It is not recommended that parameters are changed unless absolutely necessary. If incorrect parameter settings are suspected, reload the complete parameter set.

**Reset**

Returns the controller back to factory settings. Parameter set must be reloaded after performing a reset.

**Manual test**

Allows inspection of input values from sensors, and check the effects of output adjustments to peripherals, and to run preset test routines.

**Statistics**

Displays logged values and event counts to assist with fine tuning and diagnostics.

**About**

Lists the properties of the refrigeration system and the controller, including cooler model codes, firmware, hardware and software versions.

## SCS Connect Field App and Track App

**Connecting** Follow the procedures below to install and set-up the app, and connect to a controller.

**Note:** The SCS Connect Field app and Track app is separate from the SKOPE-connect app.

### To install the SCS Connect Field app

1. Download and install the Connect Field app or Track app from Google Play or Apple Store (search for “scs wellington” to find it).

---

2. When you first run the app, you will be requested to enter an activation code. Contact your Service Manager or SKOPE to receive your activation code (you must be connected to the internet at the time of activation).  
Your activation code is unique to you, and should NEVER be shared with anyone else, as it determines your personal access level for the app. The same code will give you access to all SCS apps you are authorised to use.

---

3. Once activation is complete, you must define a 4-digit PIN code. This can be any code unique to you. Each time you start the app, you will be required to enter this same PIN code. This is to prevent other people accessing the app from unlocked phones.

---

4. You can see which databases you are activated against from the “Settings” screen. You can be activated to more than one database at the same time. Simply select ACTIVATE ANOTHER DATABASE, and enter the new databases unique activation code, as in Step 2.

### To connect to a controller

1. Check that the Bluetooth logo on the top right of the controller faceplate is unlit, and when connection is achieved it will begin to flash.  
**Note:** A flashing Bluetooth logo indicates that the controller is currently connected to a device.

---

2. Open the SCS Connect Field app.

---

3. Select a controller to connect to from the list of visible controllers.  
**Note:** This list is filtered by your activation permissions, so devices you are not authorised to connect to will not be displayed.

---

4. Select ‘connect’ to connect to the controller.

---

5. Check that the Bluetooth logo on the top right of the controller faceplate is flashing, indicating that the controller is connected.

**App Categories** Various options are available in the app menu to provide information about the connected controller and its cooler. Depending on user access level, some menu options may not be available.

**Home screen**

The home screen shows a graphic representation of the current state of the cooler or freezer being controlled.

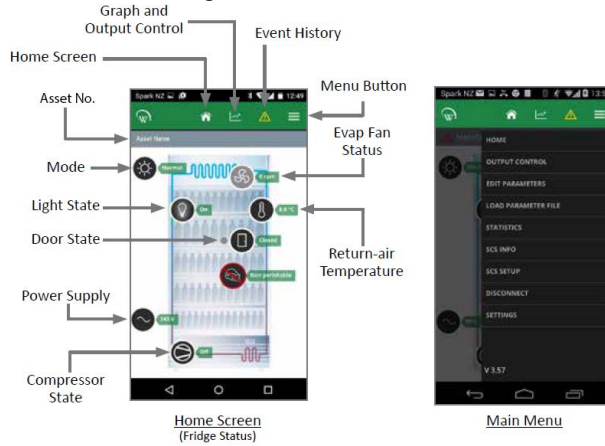

**Output control**

Provides control of the controller input sensors and switches, and output relays.

**Edit parameters**

Provides access and editing of individual controller parameters.

**Note:** Parameter changes must be recorded on warranty/job card.

It is not recommended that parameters are changed unless absolutely necessary. If incorrect parameter settings are suspected, reload the complete parameter set. **Note:** Updated parameters are not applied until DISCONNECT has been selected from the menu (after loading new parameter set).

**Load parameter file**

Allows reloading of cooler default parameter set or changing to new parameter set. See See “Replacing the Controller” on page 62 for instructions. **Note:** Updated parameters are not applied until DISCONNECT has been selected from the menu (after loading new parameter set).

	Model Number	TMF-N Models	SKTF-N Models
<b>Parameter Numbers</b>	613	✓	✓

**Statistics**

Information from the past seven days on cooler activity including temperatures, door openings and alarms.

**SCS info**

Controller version and cooler asset information.

**SCS setup**

Add or change SCS info (see above).

**Disconnect**

Disconnect from currently connected controller.

**Settings**

Change app general settings.



## Faults and Alarms

The following table explains faults and alarms that the electronic controller may log and display.

If a fault occurs, the fault - alarm indicator is lit on the controller faceplate, but no message is displayed. Faults do not affect product temperature, and require no action from the shop owner.

Alarms are logged and the alarm message is displayed on the controller faceplate. Alarms may result in abnormal product temperature.

Some faults and alarms can be cleared by the shop owner, and others can only be cleared by a service technician.

If the cooler is connected to the power supply and has warm product, check the SCS Connect Field App for active fault or alarm, and investigate. If the cooler does not have an active fault or alarm, check the app statistics to determine if and when the controller signalled a fault or alarm.

Refer to the tables below for faults and alarm descriptions and possible causes and actions. The service tech type column refers to the service tech skill level required to complete a task. Refer to the “SKOPE HC Service Requirements” on page 6 for service tech type details.

### Faults

Description	Service tech type	Possible root cause
Door left open. The door has been open for several minutes. Excessive door open counts	1, 2, 3, 4	- door not self closing (torsion fault) - door switch / circuit - controller
Over-voltage protection The maximum allowable mains supply voltage has been exceeded. The cabinet has temporarily shut down to prevent damage and will restart once the supply voltage decreases.	1, 2, 3, 4	- should be a one off; if continues: - line voltage / rural - voltage setting parameter - controller
Under-voltage protection The mains supply voltage has dropped below the minimum allowable level. The cabinet has temporarily shut down to prevent damage and will restart once the supply voltage increases.	1, 2, 3, 4	- should be a one off; if continues: - power supply overloaded / multi-box - line voltage / rural. - voltage setting parameter - controller
High condensing temperature protection The system was operating at an elevated temperature and has temporarily shut down to prevent damage. Extended operation in this condition may result in ALARM 15, increased energy consumption and a reduction in cabinet life. This alarm may be caused by very high ambient temperature.	2, 3, 4	NO swap unit required - condenser not clean - poor installation / ventilation - condenser fan motor / blade - controller
Excessive compressor cycling protection The system has been turning on and off too frequently.	2, 3, 4	Take spare unit in case refrigeration system fault. - condenser blocked - poor installation / ventilation - cabinet / unit gasket seals leaking - door not self closing / gasket leaking - product; hot / blocking cabinet airflow - overloaded from excess door openings / ambient - fan motor / blade (condenser / evaporator) - controller - compressor / gas leak = SWAP unit

### Alarms

Code	Description	Service tech type	Possible root cause
dor	Door left open. The door has been open for several minutes. Will revert to door left open FAULT after 10 minutes (see faults table on previous page).	1, 2, 3, 4	- door not self closing (torsion fault) - door switch / circuit - controller

*Continued over the page*

Code	Description	Service tech type	Possible root cause
8	Estimated product temperature below allowable range  The estimated product temperature has been below the allowable range for longer than the permissible time. Potential causes are: an empty or partially filled cabinet, or low ambient temperature.	1, 2, 3, 4	- low ambient - App settings - controller
9	Estimated product temperature above allowable range  The estimated product temperature has been above the allowable range for longer than the permissible time. Potential causes are: excessive door openings, door being left open, or warm product loaded into cabinet.	2, 3, 4	NO Swap unit required to be taken (but may be required as fault could still be with sealed refrigeration system) - condenser blocked - poor installation / ventilation - frozen blocked evaporator coil - unit gasket leaking (to cabinet seal / lid seal) - door leaking air (bad gasket / door not self closing) - product; hot / blocking cabinet airflow - overloaded from excess door openings / ambient - fan motor / blade (condenser / evaporator) - App settings - controller - compressor / gas leak = arrange SWAP unit
15	Excessive condensing temperature protection  The system was operating at an excessive temperature and has shut down to prevent permanent damage. This alarm may occur due to very high ambient temperature.	2, 3, 4	NO swap unit required - condenser not clean - poor installation / ventilation - condenser fan motor / blade - controller
17	Control probe failure  A critical system sensor has failed and the cabinet can no longer operate.	2, 3, 4	NO swap unit required - control Probe / circuit - controller
18	Electrical over-current protection activated  The compressor was drawing too much current and has shut down to prevent permanent damage.	2, 3, 4	Take spare unit in case refrigeration system fault. - condenser blocked - poor installation / ventilation - cabinet / unit gasket seals leaking - door not self closing / gasket leaking - product; hot / blocking cabinet airflow - overloaded from excess door openings / ambient - fan motor / blade (condenser / evaporator) - controller - compressor / gas leak = SWAP unit
19	Failed to reach set temperature  The refrigeration system has been operating continuously for a long period without reaching the set temperature.	2, 3, 4	Take spare unit in case refrigeration system fault. - condenser blocked - poor installation / ventilation - frozen blocked evaporator coil - cabinet seal leaking / door / unit - product; hot / blocking cabinet airflow - overloaded from excess door openings / ambient - fan motor / blade (condenser / evaporator) - controller - compressor / gas leak = SWAP unit
20	Over cooling product  The internal temperature is too low. The system has temporarily shut down until the temperature has returned to normal. This can occur if the set temperature has been raised by a large amount.	1, 2, 3, 4	- confirm if really too cold; change parameters accordingly
22	Evaporator fan over-current protection  The current supplied to the evaporator fan motor is too high.	2, 3, 4	NO swap unit required - faulty fan motor - fan blade fault (imbalance / debris / blockage) - controller
23	Condenser fan over-current protection  The current supplied to the condenser fan motor is too high.	2, 3, 4	NO swap unit required - faulty fan motor - fan blade fault (imbalance / debris / blockage) - controller
24	Controller communication error  Controller has lost communication channels.	1, 2, 3, 4	- App - controller / circuit

Continued over the page

Code	Description	Service tech type	Possible root cause
25	Controller update failed Controller update could not be completed.	1, 2, 3, 4	- App - controller / circuit
26	Controller hardware failure Controller hardware has failed.	1, 2, 3, 4	- App - controller / circuit
27	Probe failure A non-critical system probe has failed. The cabinet will continue to operate with partial function but requires service.	2, 3, 4	NO swap unit required - evaporator probe / connections - controller
28	No downward tendency The temperature is no longer decreasing.	2, 3, 4	Take spare unit in case refrigeration system fault. - condenser blocked - poor installation / ventilation - cabinet / unit gasket seals leaking - door not self closing / gasket leaking - product; hot / blocking cabinet airflow - overloaded from excess door openings / ambient - fan motor / blade (condenser / evaporator) - controller - compressor / gas leak = SWAP unit
29	Compressor cutting out The compressor cut out on its internal protection or pressure switch.	2, 3, 4	Take spare unit in case refrigeration system fault. - condenser blocked - poor installation / ventilation - cabinet seal leaking / door / unit - product; hot / blocking cabinet airflow - overloaded from excess door openings / ambient - fan motor / blade (condenser / evaporator) - controller - compressor / gas leak = SWAP unit
30	Excessive automatic defrosting The system is automatically defrosting too frequently.	2, 3, 4	Take spare unit in case refrigeration system fault. - door not self closing / gasket leaking - Evaporator probe - Evaporator motor / fan - controller - compressor / gas leak = SWAP unit
31	Compressor stalling The compressor is stalling on start up.	2, 3, 4	Take spare unit in case refrigeration system fault. - condenser blocked - poor installation / ventilation - cabinet / unit gasket seals leaking - door not self closing / gasket leaking - product; hot / blocking cabinet airflow - overloaded from excess door openings / ambient - fan motor / blade (condenser / evaporator) - controller - compressor / gas leak = SWAP unit

# 4 Wiring

Model: TMF/SKFT650N/1000N

### WIRE COLOURS

BK	Black
BN	Brown
RD	Red
OG	Orange
GN	Green
BU	Blue
GY	Grey
WH	White
GNYE	Green-Yellow
Based upon IEC 757 Standard	

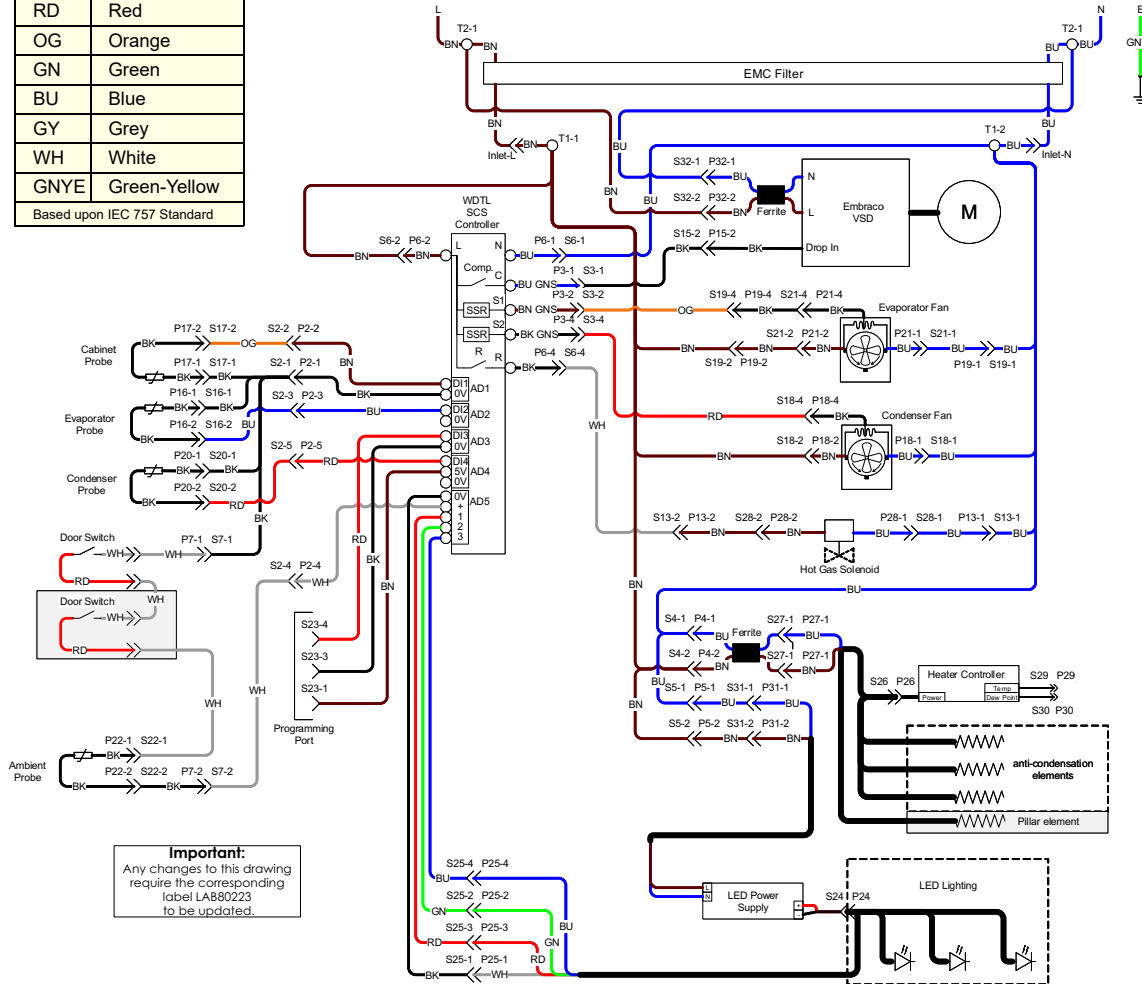

**Important:**  
Any changes to this drawing require the corresponding label LAB80223 to be updated.

### LEGEND

Internal Unit Junction Box Sockets/Plugs	
Inlet	IEC Cabinet Socket/Plug
S1/P1	Not Used
S2/P2	Unit Junction Box to Controller Signal Socket/Plug (6-way)
S3/P3	Unit Junction Box to Controller Power Socket/Plug (Blue 4-way)
S4/P4	Lighting/Heater Wire Unit Socket/Plug (Black 3-way)
S5/P5	Lighting/Heater Wire Unit Socket/Plug (Black 3-way)
S6/P6	Unit Junction Box to Controller Power Socket/Plug (Red 4-way)
S7/P7	Door Sensor Socket/Plug (White 2-way)
S8/P8	Not Used
S9/P9	Not Used
S10/P10	Not Used
S11/P11	Not Used
S12/P12	Not Used

Continued over the page

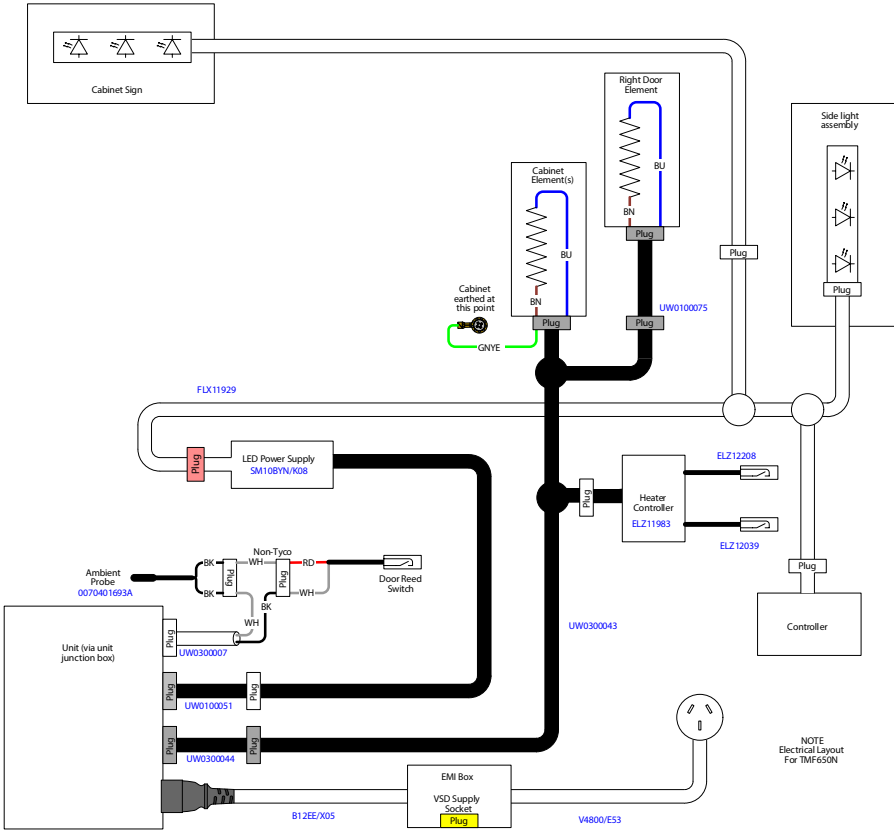
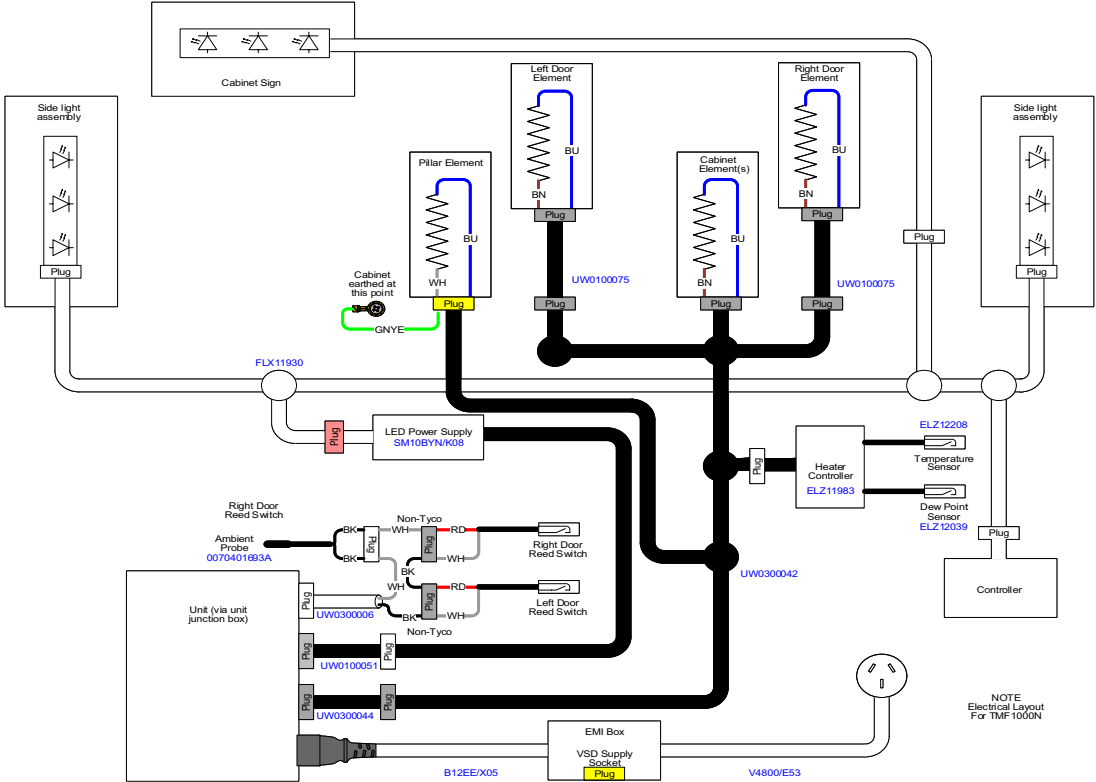

**LEGEND**

S13/P13	Hot Gas Solenoid Unit Socket/Plug (White 3-way)
S14/P14	Not Used
S15/P15	Compressor Unit Socket/Plug (Blue 4-way)
S16/P16	Evaporator Sensor Socket/Plug (Black 2-way)
S17/P17	Cabinet Sensor Socket/Plug (Blue 2-way)
S18/P18	Condenser Motor Unit Socket/Plug (Red 4-way)
S19/P19	Evaporator Motor Unit Socket/Plug (White 4-way)
S20/P20	Condenser Sensor Socket/Plug (Red 2-way)
T1	Unit Terminals
T2	EMI Filter Box Terminals
<b>External Sockets/Plugs</b>	
S21/P21	Evaporator Motor Extension Socket/Plug (Red 4-way)
S22/P22	Ambient Sensor Socket/Plug (White 2-way)
S23/P23	Programming/Comms Port Socket (Blue 4-way)
S24/P24	LED Driver DC Out Put Socket/Plug (Red 2-way)
S25/P25	LED Lighting Loom Socket/Plug (White 6-way)
S26/P26	Heater Controller Socket/Plug (White 4-way)
S27/P27	Cabinet Heating Loom and Ferrite Plug/Socket (Black 3-way)
S28/P28	Hot Gas Solenoid Extension Socket/Plug (White 4-way)
S29/P29	Heater Controller Temperature Controller
S30/P30	Heater Controller Dew Point Sensor
S31/P31	LED Driver AC Extension Flex Socket/Plug (White 3-way)
S32/P32	Unfiltered VSD Supply Socket/Plug (Yellow 4-way)



## 5 Spare Parts

### Main Assembly - TMF/SKFT650N Series

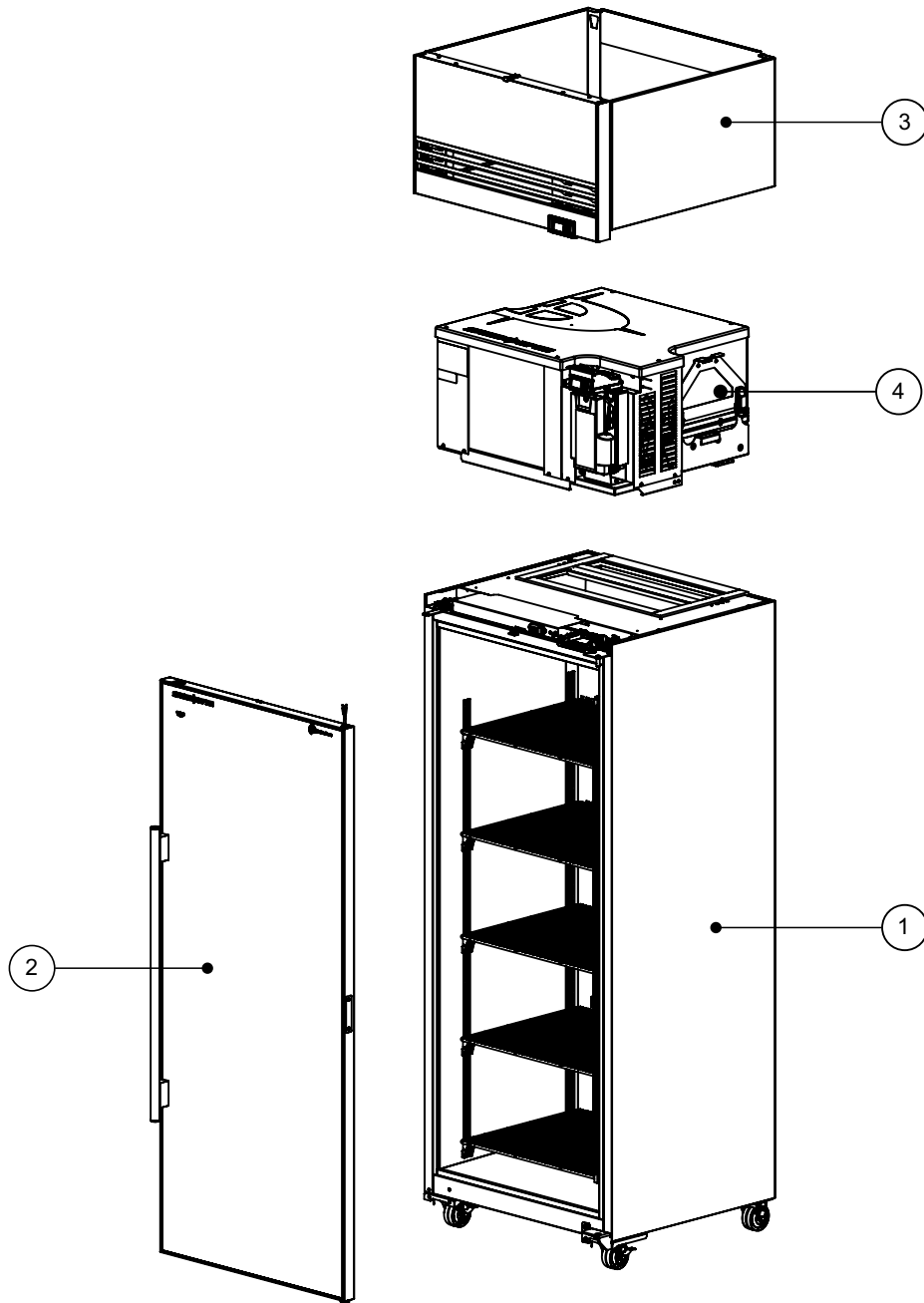

#### Parts - Main Assembly TMF650N Series

No.	Description	Page
1	Cabinet assembly	Page 22
2	Door assembly	Page 24
3	Sign assembly	Page 25
4	Unit assembly	Page 26



# Main Assembly - TMF/SKFT1000N Series

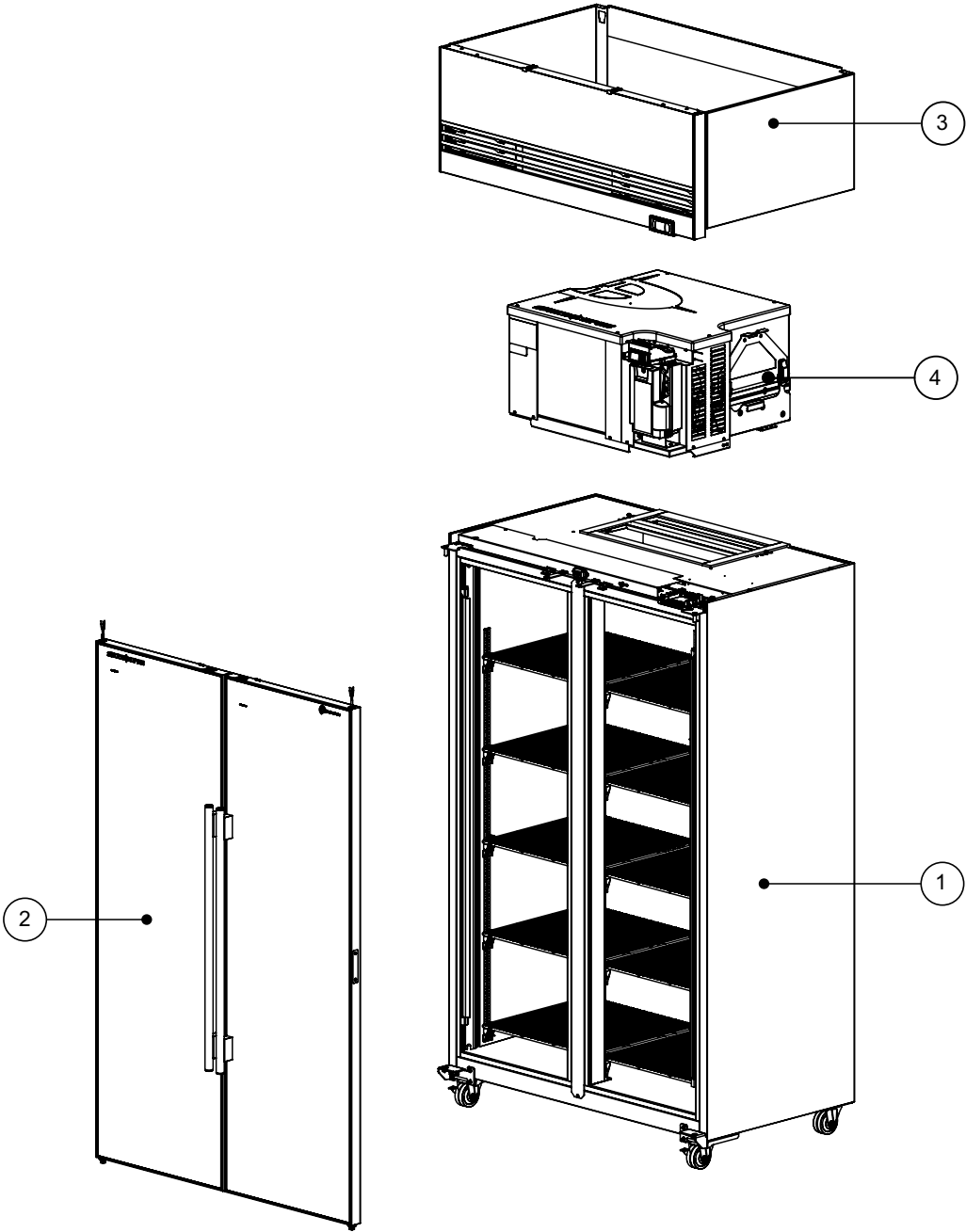

## Parts - Main Assembly TMF1000N Series

No.	Description	Page
1	Cabinet assembly	Page 23
2	Door assembly	Page 24
3	Sign assembly	Page 25
4	Unit assembly	Page 26

## Cabinet Assembly - TMF650N Series

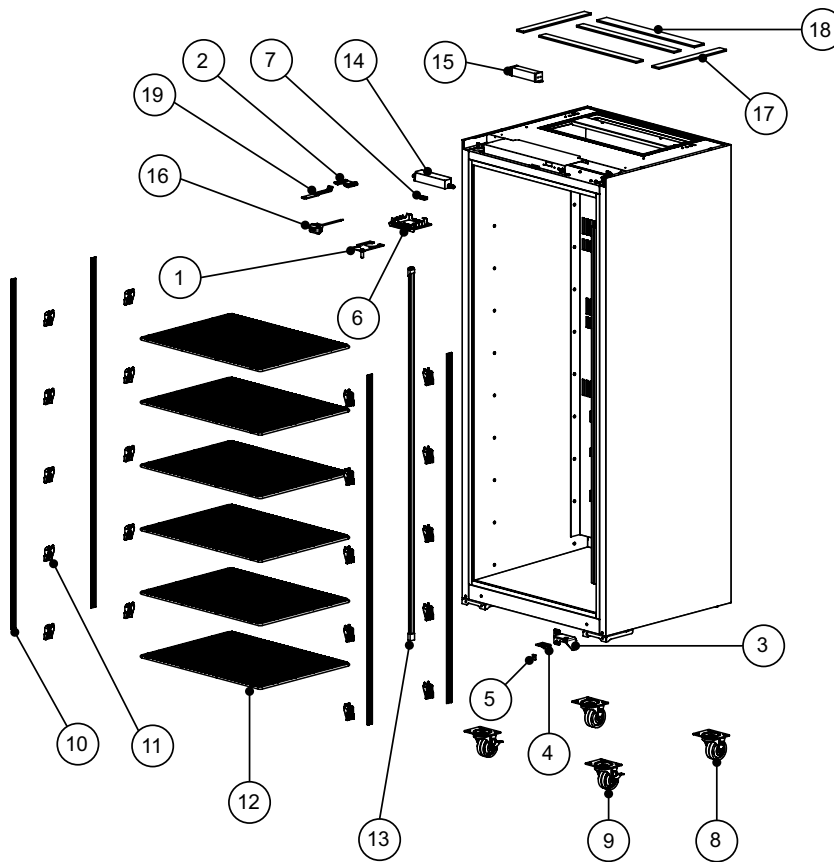

### Parts - Cabinet Assembly TMF650N Series

No.	Description	Spares Part Number	
		Unpainted/standard	Colour: White
1	Top hinge – right hand	-	HB0070110582
2	Sliding lock bush	-	HB0070206938
3	Bottom hinge – right hand	-	HB0070110851
4	Tension bracket	HB0070110580	-
5	Height adjustment block lock nut	HB0070110581	-
6	Controller clip	-	HB0070206333
7	Door sensor assembly (includes magnet)	HB0074091496	-
8	Rear castor	HB0070105066	-
9	Front castor lockable	HB0070105065B	-
10	Shelf support strip	HB0070110331	-
11	Shelf clip	-	HB0070205867
12	Wire shelf	-	HB0070110864
13	LED light	ELL11771	-
14	Light power supply	SM10BYN/K08	-
15	Heater controller	ELZ11983	-
16	Dew point sensor	ELZ12039	-
17	Inseal 35 × 6	RUE12328	-
18	Inseal 50 × 6	RUE5120	-
19	Door lock bracket	HB0070111623	-

## Cabinet Assembly - TMF1000N Series

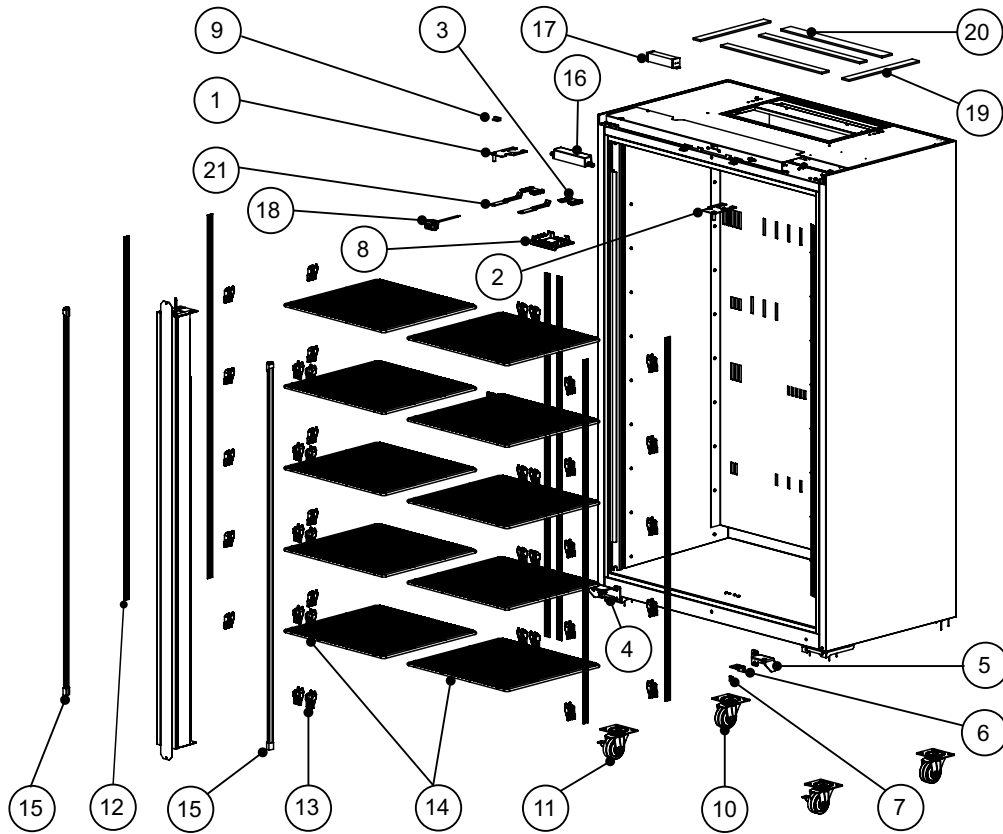

### Parts - Cabinet Assembly TMF1000N Series

No.	Description	Spares Part Number	
		Unpainted/standard	Colour: White
1	Top hinge – left hand	-	HB0070110583
2	Top hinge – right hand	-	HB0070110582
3	Sliding lock bush	-	HB0070206938
4	Bottom hinge – left hand	-	HB0070110850
5	Bottom hinge – right hand	-	HB0070110851
6	Tension bracket	HB0070110580	-
7	Height adjustment block	HB0070110581	-
8	Controller clip	-	HB0070206333
9	Door sensor assembly (includes magnet)	HB0074091496	-
10	Rear castor	HB0070105066	-
11	Front castor lockable	HB0070105065B	-
12	Shelf support strip	HB0070110331	-
13	Shelf clip	-	HB0070205867
14	Wire shelf – split (10 per cabinet)	-	HB0070110862
	Wire shelf – wide (5 per cabinet)	-	HB0070110863
15	LED light	ELL11771	-
16	Light power supply	SM10BYN/K08	-
17	Heater Controller	ELZ11983	-
18	Dew Point Sensor	ELZ12039	-
19	Inseal 35 × 6	RUE12328	-
20	Inseal 50 × 6	RUE5120	-
21	Door lock bracket	HB0070111623	-

## Glass Door Assembly

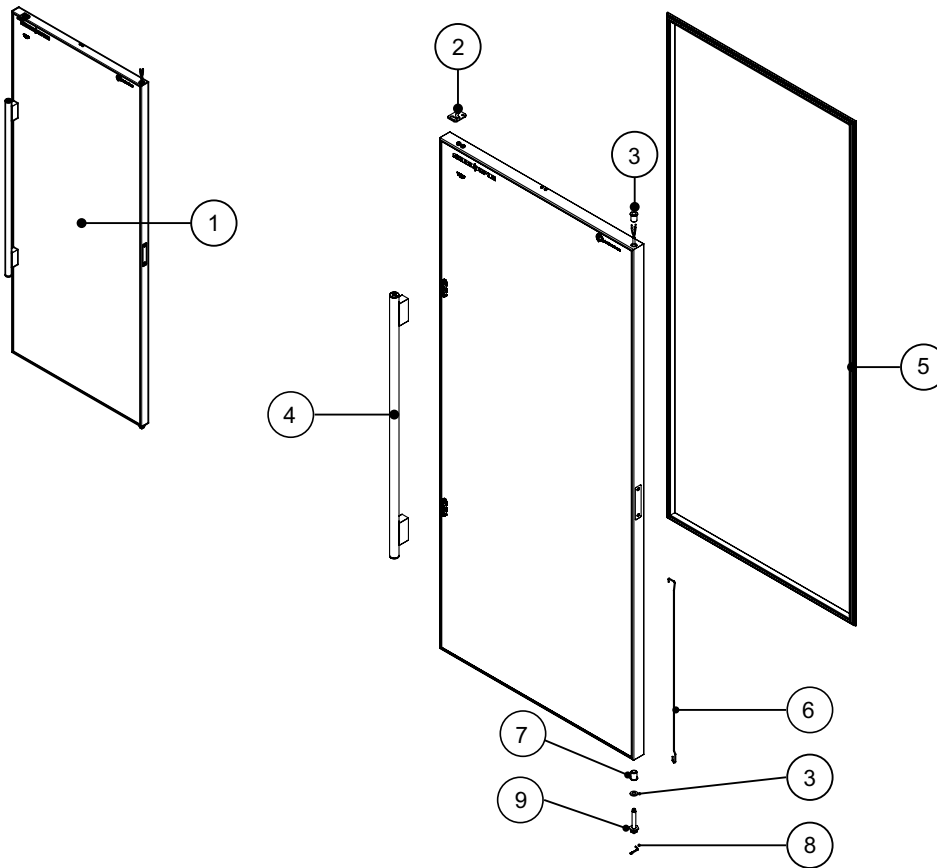

### Parts - Glass Door Assembly

No.	Description	Spares Part Number	
		<i>Unpainted/standard</i>	<i>Colour: White</i>
1	TMF650N door assembly – right hand	-	GLD12437R-WH
	TMF1000N door assembly – right hand	-	GLD12438R-WH
	TMF1000N door assembly – left hand	-	GLD12438L-WH
2	Top lock plate	SM60BV/348-BK	SM60BV/348-WH
3	Bush	PLM5075	-
4	Door handle	-	HAN11195/0844-AS (silver, for white door)
5	TMF650N magnetic gasket	GKT0432SK	-
	TMF1000N magnetic gasket	GKT0572SK	-
6	Torsion bar	REF5014	-
7	Bush washer	PLM11298	-
8	Capstan	TUR11299	-
9	Split pin	FAS5076	-

# Sign Assembly

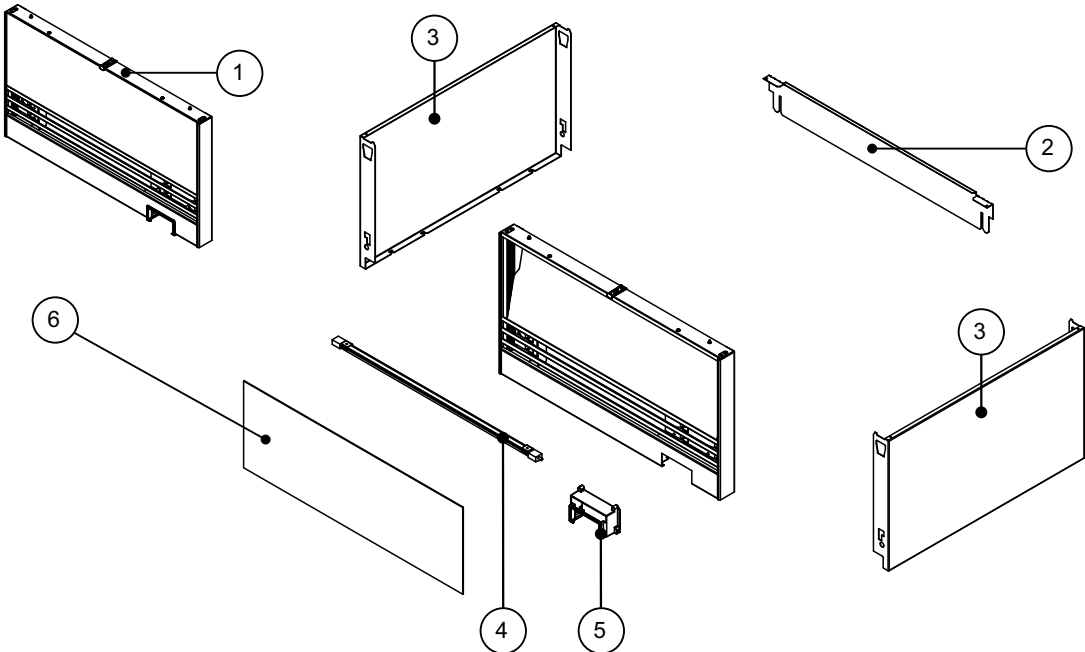

### Parts - Sign Assembly TMF650N

No.	Description	Spares Part Number
1	Lit sign assembly	LT65BYN/T61
	Non-lit sign assembly (sign replacement panel)	LT65GYN/T40
2	Sign back strip	LTH65BYN/C53
3	Sign side	SM65BV/182
4	Sign light bar (lit-sign)	ELL11772
5	Controller surround	HB0070206332
6	Sign panel (transparent) (lit-sign)	PLY11241-LT65

### Parts - Sign Assembly TMF1000N

No.	Description	Spares Part Number
1	Lit sign assembly	LT10BYN/T61
	Non-lit sign assembly (sign replacement panel)	LT10GYN/T40
2	Sign back strip	LTH10BYN/C53
3	Sign side	SM65BV/182
4	Sign light bar (lit-sign)	ELL11773
5	Controller surround	HB0070206332
6	Sign panel (transparent) (lit-sign)	PLY11241-LT65

# Unit Assembly UTHDNI-0043

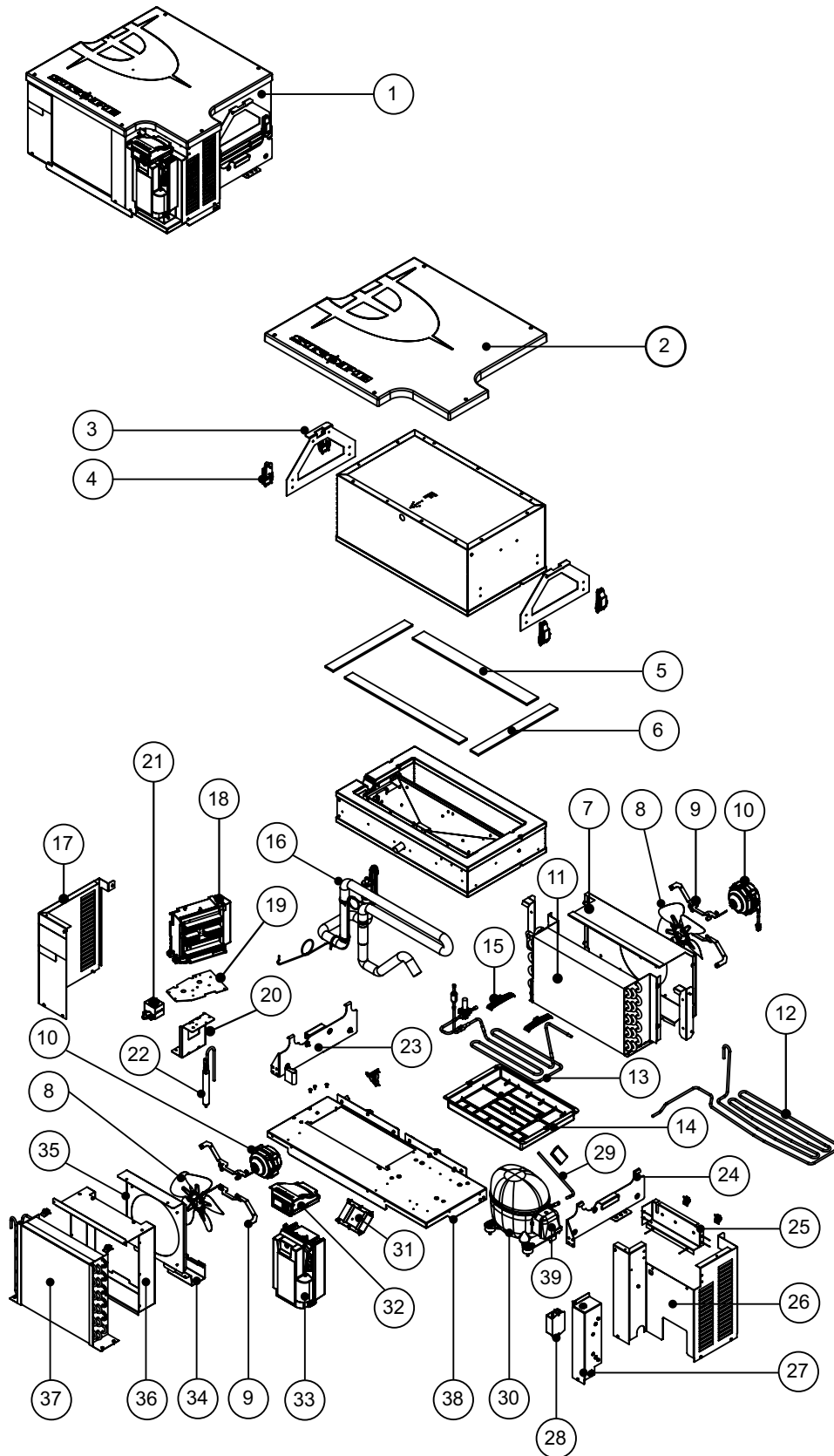

## Parts – Unit Assembly

No.	Description	Spares Part Number
1	Unit assembly	UTHDNI-0043
2	Top Cover	HB0070210740
3	Lid Handle Support	US04N00020
4	Over Centre Latch	SXX12296
5	Inseal 50 × 6	RUE5120
6	Inseal 35 × 6	RUE12328
7	Evaporator Shroud	US02N00021
8	Fan Blade Ø200 28°	HB0074000313
9	Fan Motor Bracket	HB0070113982
10	ECR2-0361 Fan Motor ECR2-0361 WDTL	ELM11309
11	Evaporator Coil – 1.0 Circuit	HB0070703152
12	Tube Hot Gas	HB0070703153
13	Pipework – Condensate	HB0070702906
14	Condensate Tray	HB0070210452
15	Condensate Pipe Support	HB0070206128
16	Pipework Suction line Assembly	HB0070702861
17	Unit Left Hand Side Cover	US04N00014
18	Inverter (Compressor power supply)	HB0071800233
19	Inverter Top Bracket	US05N00016
20	Inverter Bracket	HB0070114715
21	Solenoid Valve Assembly	HB0074000545A
22	20GN Spun Drier	HB0070700780
23	Bracket Left Hand Tub Side	HB0070114713
24	Bracket Right Hand Tub Side	HB0070114712
25	Cover Unit Front Top	US04N00015
26	Unit Right Hand Side Cover	US04N00013
27	Cover EMI Filter	HB0070114716
28	Schaffner EMI Filter N2030Z-10-06	ELZ10136
29	Process Tube	HB0070703196
30	Embraco Compressor – VNEU217U	HB0074001133
31	Bracket Unit Brace	HB0070114717
32	“Electronic Controller Assembly” on page 28	
33	“Unit Junction Box Assembly” on page 29	
34	Junction Box Support Bracket	HB0070114714
35	Motor Mount	US02N00019
36	Condenser Fan Shroud	US02N00018
37	Condenser Coil	HB0070702907
38	Unit Base	HB0070114711A
39	Compressor Overload Protector (NS)	SXX12497

## Electronic Controller Assembly

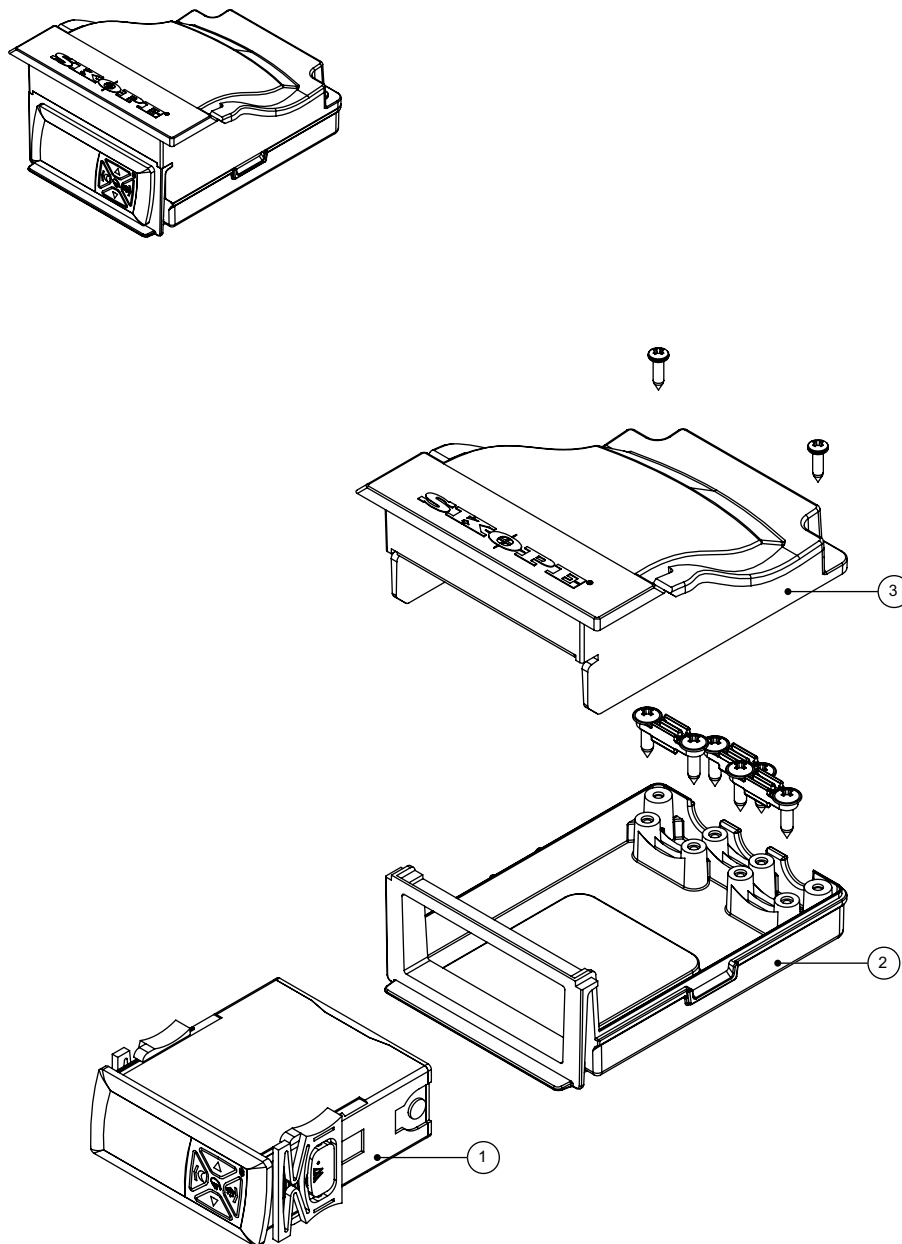

### Parts - Electronic Controller

Item	Description	Spare Part Number
0	Electronic controller assembly	
1	WDTL SCS electronic controller (programmed)	ELZ11749-1629
2	Controller housing base	UP09N00004
3	Controller housing cover	UP09N00005



# Unit Junction Box Assembly

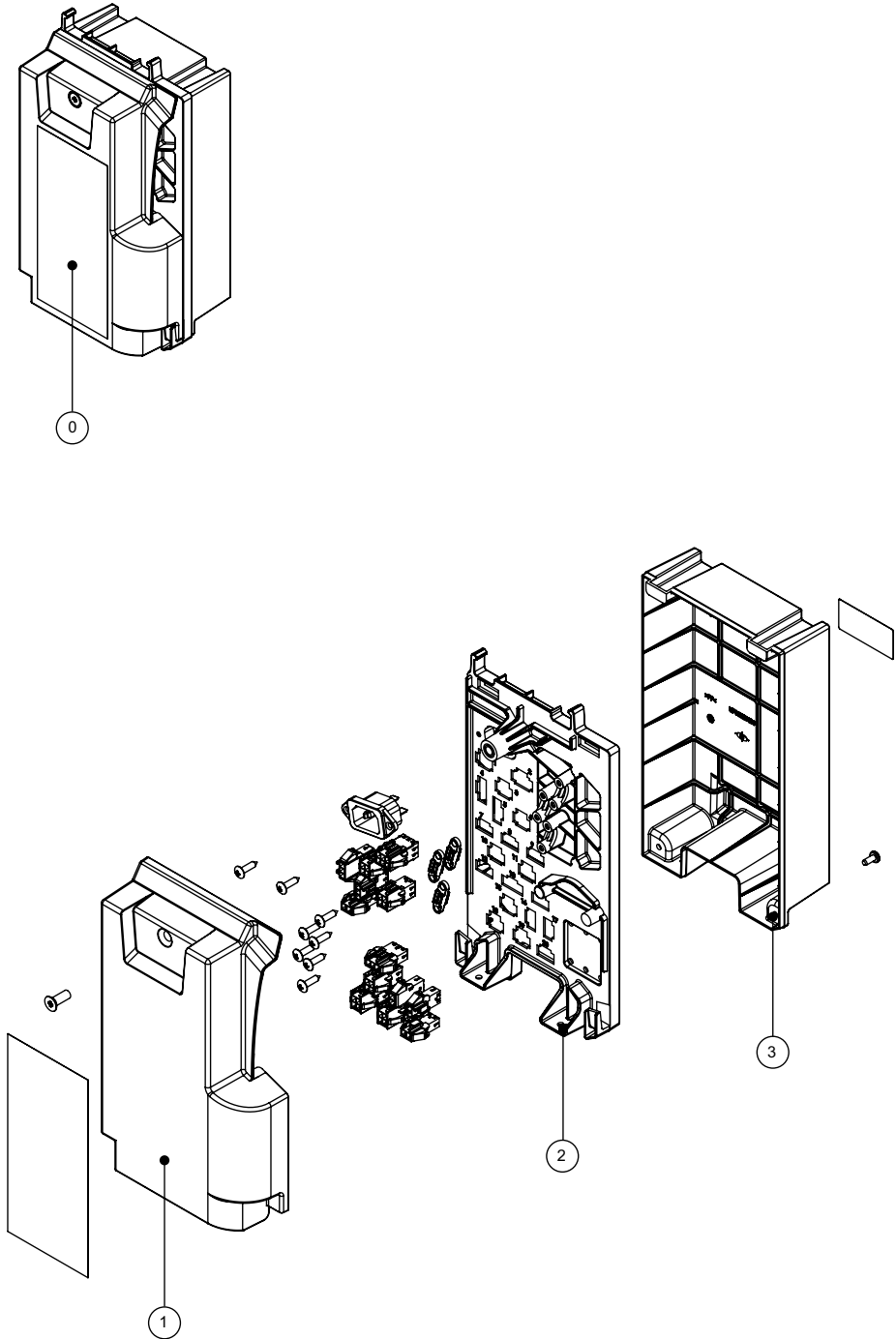

## Parts - Unit Junction Box

Item	Description	Spares Part Number
0	Unit junction box assembly	
1	Electrical front panel	HB0070207012A
2	Electrical enclosure panel	HB0070207014
3	Electrical rear panel	HB0070207013A

## 6 Installation

### Installation Guidelines

When installing this cabinet, ensure the installation guidelines below are considered and met.

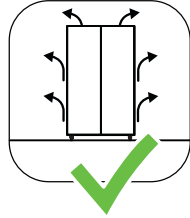

**Ventilation**  
Ensure all ventilation requirements below are met.

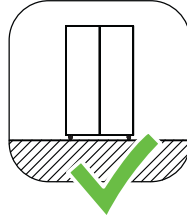

**Surface**  
The installation surface must be capable of supporting the loaded cabinet.

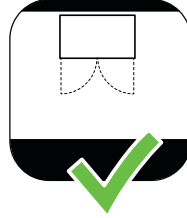

**Door Opening**  
Allow adequate space for the door/s to open and close properly.

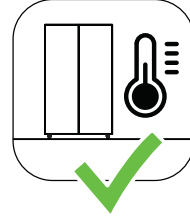

**Climate Class**  
The freezer must be installed in an environment within its climate class.  
The climate class is stated on the cabinet rating label inside the freezer.

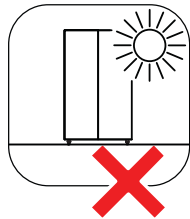

**Sunlight**  
Do not install the freezer in direct sunlight.

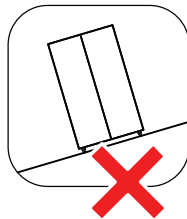

**Uneven Surface**  
Do not install the freezer on an uneven surface.

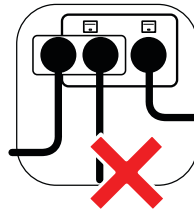

**Power Supply**  
Do not overload the power supply.

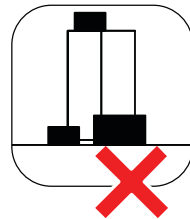

**Blocking Ventilation**  
Do not store boxes or items in front or on top of the freezer.

## Ventilation Requirements

Adequate ventilation around the refrigeration unit is essential for efficient operation. See the diagram below for ventilation requirements.

When positioning the freezer, ensure there is at least a 300mm space above the top panel. In certain climatic conditions, condensation may form on the back of the cabinet. If this is observed, ensure air circulation between cabinet and wall by adhering two of the enclosed self-adhesive blocks to the cabinet back as shown.

The air surrounding the refrigeration unit must not exceed 40°C. Keep the ventilation slots at the top of the cabinet clear at all times and **never** store cardboard cartons or other objects on top of the freezer.

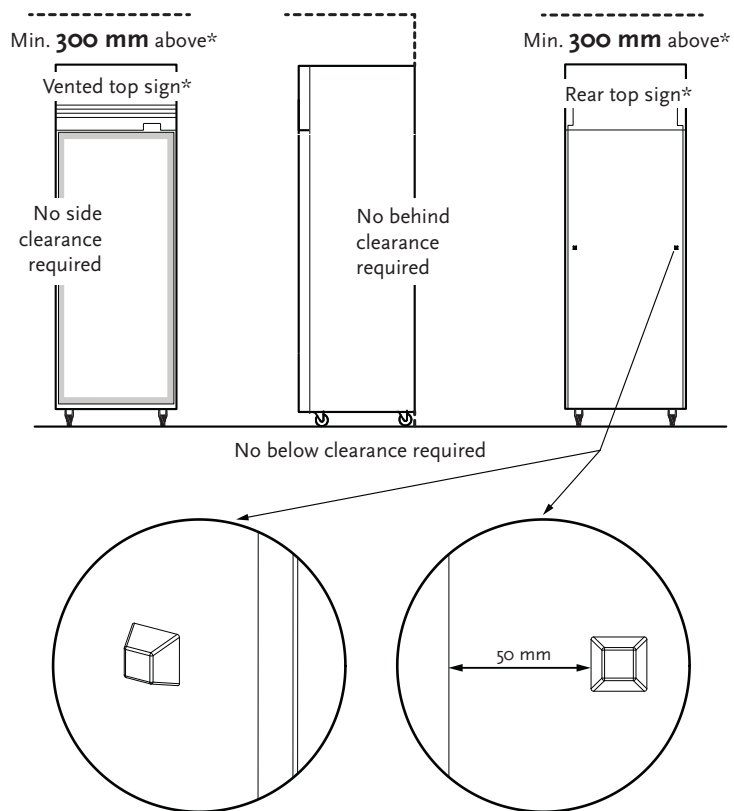

### Adhesive Blocks

If required use two adhesive blocks on the rear of the cabinet. Position the blocks on the left and right hand sides of the cabinet, approximately central vertically, and 50 mm from the edge of the cabinet.

## Door Handles

**Fitting Door Handles** For transit purposes the door handles may be packed separately inside the cabinet. If the door handles are packed separately, follow the steps below to fit them to the door/s.

### To fit a door handle

1. Remove the handle/s from inside the cabinet by carefully cutting the cable ties securing the handle, and remove the packaging.

2. A metal spring clip is fitted inside the handle mounts at each end of the handle.  
Ensure that the spring clips point up.

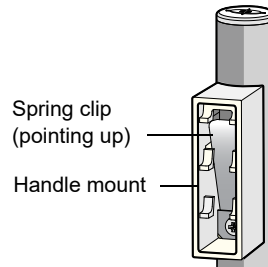

3. Position **BOTH** handle mounts simultaneously onto both door brackets. Then push the handle down onto the brackets, until the handle locks into place.

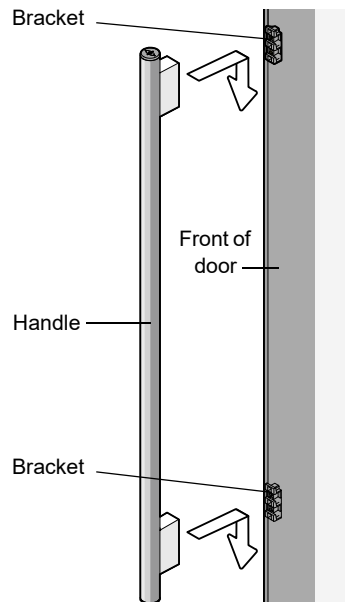

#### CAUTION

Ensure **BOTH** handle mounts are in position before pushing down.

4. If the handle does not lock into place, check that the spring clips are pointing up and try again.  
If only one end of the handle locks into place, unscrew the door handle (see over page), and refit ensuring both of the handle mounts are placed onto the brackets before pushing the handle down and locking into place.

**Removing Door Handles** The door handles can be removed for transporting and moving the cabinet through doorways, or for refitting.

### To remove a door handle

1. Open the door, and peel back the door gasket from behind the handle mounts on the inside of the door frame.
2. Unscrew the handle mounts through the holes on the inside of the door frame (top and bottom screws only), and remove the handle.

3. Remove the bracket/s from the handle mount by pressing the bracket in and down until it unclips from the handle mount.

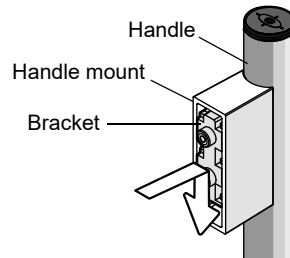

4. Fit and screw the bracket/s back onto the door. Ensure the catches are pointing up as pictured.

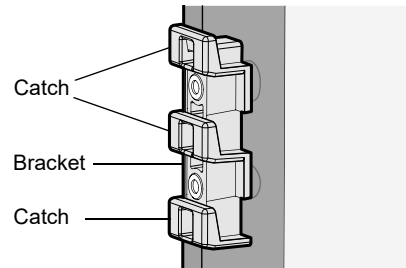

5. Refit the door gasket by clipping it back into place on the inside of the door frame. If the gasket is out of shape after refitting it, a hair drier can be used to heat and reshape it.

## Shelves

The freezer is fitted with five wire shelves per door, which may be positioned at different heights to suit various products.

**Shelf Clips** Each wire shelf is held in place with four shelf clips, which engage in the shelf support strips and slide up and down to the desired shelf position.

The support strips are numbered for easy placement of shelf clips. You can see the numbers in the bottom left hand corner of the shelf clip.

### To fit a shelf clip

1. The shelf clip twists onto the shelf support strip. Position the shelf clip with the flat side up against the shelf support strip and the two prongs pointing up. Twist the top of the clip anticlockwise onto the shelf support strip until it locks in place.

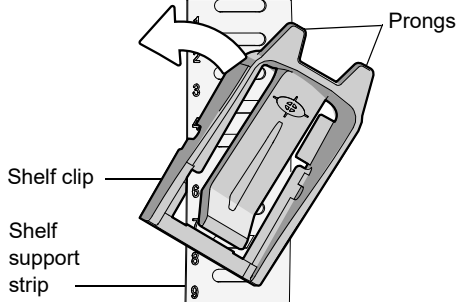

### To adjust the shelf clip height

1. Pull the shelf clip tab up and slide the shelf clip up or down as required. Once in position, ensure the shelf clip is locked into place.

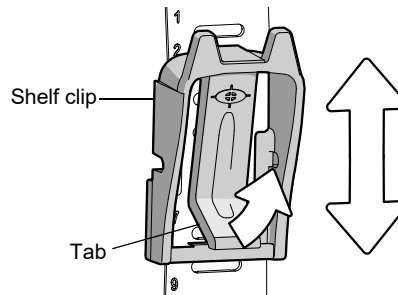

### To remove a shelf clip

1. Pull the shelf clip tab up and twist the top of the clip clockwise off the shelf support strip.

### Repositioning Shelves

When repositioning standard shelves, unload and remove the shelf, establish the desired position and slide the shelf clip in each of the shelf support strips to the desired position see **“To adjust the shelf clip height”** above. Sit the shelves on the shelf clips.

## 7 Operation

---

### Loading Product

---

---

Let the cabinet run for 30 minutes before loading it with product for the first time. When loading the cabinet:

- Do not load product above the load limit indicators shown on the cabinet interior sides

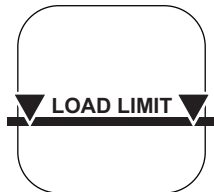

- Do not exceed a maximum load of 46kg per shelf (standard shelves) or 300kg per shelf (heavy duty ice shelves).
- Remove some product if the shelves are flexing and do not let anything hang over the shelves because this might stop the doors from shutting or break something.

### Light Switch

---

---

The lights can be switched on and off by pressing and holding the **AUX** button on the electronic controller display (see page 9).

## Cabinet Heat Control

**Overview** The cabinet Heater Controller Assembly is used to control the power output of the anti-condensation heating elements located in the cabinet doors and the cabinet front fascia. Using sensors to read the ambient conditions, the controller will only run the anti-condensation elements when they are required. This reduces the energy consumption of the cabinet.

The cabinet pillar is uncontrolled. Any condensation present on the pillar, or any sides of the cabinet that are not the front fascia, cannot be fixed by changes made to the heater controller assembly. Condensation on the sides of the cabinet indicate that it is likely operating in very high humidity.

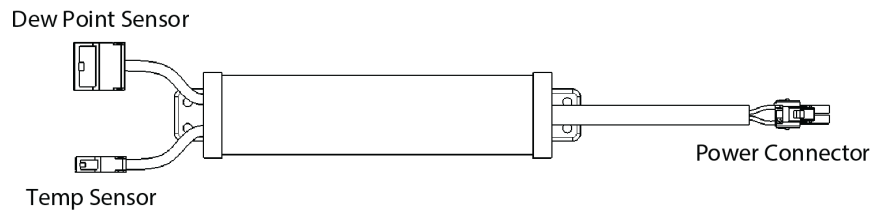

**Dew Point Sensor** The Dew Point sensor is used to measure the ambient temperature and the ambient humidity, which is used to calculate a target fascia temperature. It is mounted to the cover on the cabinet front top, and is accessible by removing the cabinet sign panel

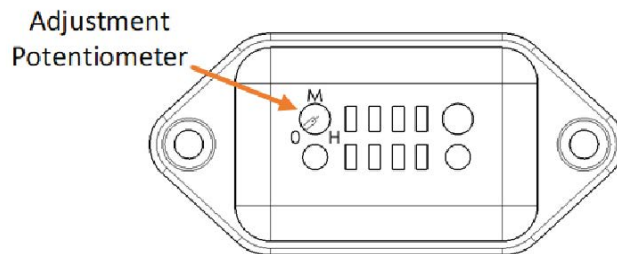

**Temp Sensor** The Temp sensor is used to measure the temperature of the front fascia to make sure it is high enough to prevent condensation. This component is foamed into the bottom front of the cabinet body and is non-serviceable.





**Trouble Shooting** If persistent condensation can be found on the exterior of the cabinet doors or fascia, use the following troubleshooting guide to determine the condition of the heater controller.

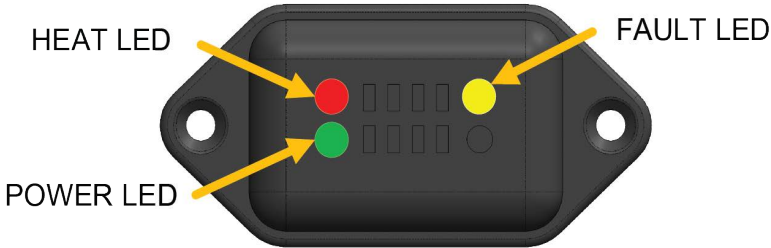

Condensation on front fascia or doors?	LED Status	Condition
N/A	○ ○ ○	There is no power to the heater. check the condition of the power and dew sensor connectors. If no damage is present, replace heater controller and dew sensor.
N/A	● ● ●	Initialisation (on start up for longer than 10 seconds)
NO	● ● ○	No issues. Power is on and heating active
NO	○ ● ○	No issues. Power is on and heating is not active
NO	● ● ●	Component Failure. Check the temp probe connector and wiring for damage. If no damage is present, replace heater controller and dew point sensor. If issue persists, there is damage to the temp sensor which is non-serviceable
YES	● ● ○	Heater duty setting is not high enough for the ambient conditions. Check that the cabinet is correctly installed in suitable conditions. If condensation persists, consider using the offset potentiometer to adjust the setting.
YES	○ ● ○	Heater duty setting is not high enough for the ambient conditions. Check that the cabinet is correctly installed in suitable conditions. If condensation persists, consider using the offset potentiometer to adjust the setting.
YES	● ● ●	Component Failure. Check all connectors and wiring for damage. If no damage is present, replace heater controller and dew point sensor.
YES	○ ● ●	Component Failure. Check all connectors and wiring for damage. If no damage is present, replace heater controller and dew point sensor.

## **Adjusting Heater Power**

If condensation persists, and the troubleshooting guide suggests no component faults are present, use the following procedure to increase the heater power.

Note!

This procedure will increase cabinet energy consumption.

Note!

Any condensation present on the pillar, or any sides of the cabinet that are not the front fascia, cannot be fixed by changes made to the heater controller assembly.

### **Procedure**

1. Remove the sign panel from the cabinet
2. Locate the dew point sensor on the front of the electrics cover
3. Use a small flat head screwdriver to carefully turn the adjustment potentiometer from the 0 position to the M position.
4. Check the LEDs on the front of the dew point sensor to ensure that the red heat LED is active.
5. Replace the sign panel, and wipe all cabinet faces clean of condensation

If the problem persists, repeat the procedure, and move the adjustment from the M position to the H position. This will significantly increase cabinet power consumption and will reduce the available cooling capacity of the cabinet.

## Hot Gas Defrost

This ActiveCore Freezer has hot gas defrost. This uses the superheated vapor from the compressor discharge as the heat source. This bypasses the condenser and expansion device and enters the evaporator via the hot gas solenoid valve, (located under the compressor inverter). From the solenoid valve, hot gas passes through under the evaporator, attached to an aluminium tray, this will defrost the evaporator drain tray and the evaporator coil.

Once the termination temperature is reached, there will be passive drip time for 4 mins, followed by 1 minute of active drip time (the evaporator fan operates).

The defrost probe is attached to the outlet of the evaporator.

Notes - typical hot gas defrost time is 2 to 8 minutes (ice dependent), every 3 hours. Max defrost time is limited to 15 minutes. If defrost runs to Max time limit there may be a refrigeration system fault because the evaporator probe at evaporator coil outlet has not reached the 15C termination temperature

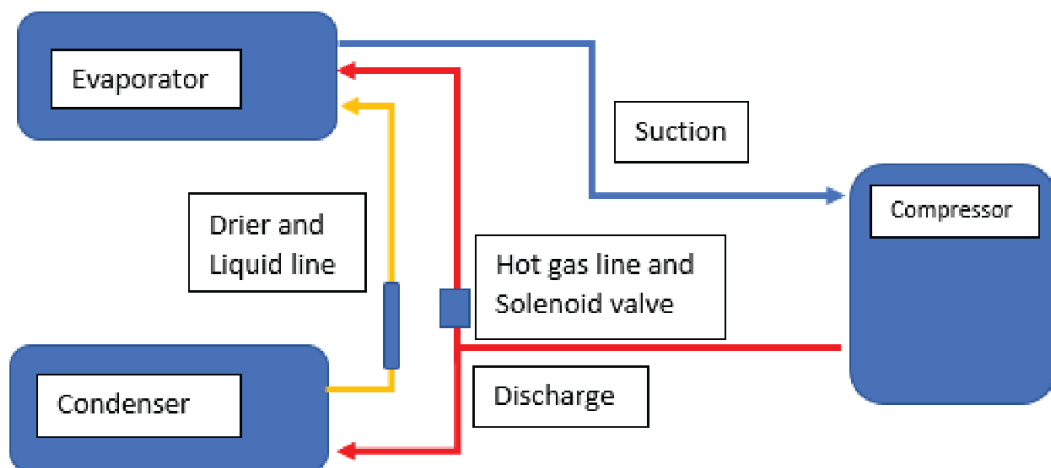

## Refrigeration System Diagnostics – Function Test

Connection into the sealed systems via line piercing valves to measure operating pressure to diagnose faults is not recommended because of the ultra low R290 charge and variable speed compressor.

Use the method below to determine whether there is a sealed system fault; before any break into the sealed system.

### Test Criteria

1. Unit may be fitted on cabinet or sitting on workbench
2. Evaporator coil (and all refrigeration system) must be soaked to room ambient temperature
3. Ambient for metrics in table is at 20°C
4. Remove unit top cover
5. Remove evaporator box top (4 latches, and lift upwards - off)
6. Sit unit top cover between front of the evaporator coil, and rear condenser fan (to prevent condenser air blowing onto evaporator coil). See image 1. below
7. If the unit is not fully plugged into cabinet - A probe (bypass) must be plugged into door plug (within electrical box)

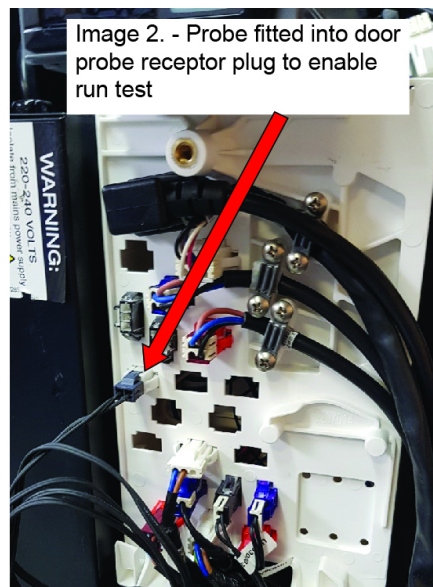

## Refrigeration System Table

Below are typical characteristics for correctly operating refrigeration system  
 The Evaporator fan start / run function as below is primary outcome to indicate correct operation.  
 If this is not met, then a fault may be present with the sealed system - refrigerant charge, compressor, inverter, defrost solenoid valve, or electrical system.  
 For controller specific issues, fault codes, etc, See “Electronic Controller” on page 8

Time - approx (after plug in)	First Plug in	20secs	1 min	2mins	5mins	7mins typically - PRIOR to Evap fan start	8mins typically - Evap fan START	After 10 minutes PRESS MANUAL Defrost	17.5mins
<b>Control display</b>	Display on, start code, then ambient temp	Ambient Temp	temp reduction				Temp increase when evaporator fan on		Temp increase
<b>Compressor</b>	OFF	ON	ON	ON	ON	ON compressor speed up (audible)	ON - hot to touch	Manual defrost duration approx 2.5mins, then 5mins DRIP time	OFF
<b>Evaporator coil</b>	dry	dry	Ice on evap capillary and evap Y inlet tube up to coil		ice on all evap coil return bends				Evap coil warm
<b>Condenser fan</b>	Twitch	ON	ON	ON	ON	ON	ON	OFF	OFF
<b>Evaporator fan</b>	Twitch	OFF	OFF	OFF	OFF	OFF	ON (approx 30secs), then off for up to 3mins	OFF	OFF, except ON for final 1 minute of defrost drip time
<b>Inverter LED</b>	One Green flash every 30 seconds								
<b>Current Amps (excluding cabinet)</b>	0.3	4.5	1.6	1.7	1.6	3.0	4.1	5.9 peak	0.2
<b>Watts (excluding cabinet)</b>	14	1020	336	367	348	664	926	1300 peak	6
<b>Field App Evaporator coil OUTLET Temp</b>	Ambient 20°C		24°C	23°C	4°C	Trigger for Evap fan ON @ - 5°C..... Then Evap fan OFF <-4°C		Increases during defrost, at 5°C defrost heating ends and compressor stops (approx 2.5minutes), then 5minute drip time	
<b>Field App Return Air Temp</b>	Ambient 20°C		23°C	20°C	6°C	Varies with fan on/off/defrost			
<b>Field App Return Air Temp</b>	Varies with fan on/off/defrost								

## Compressor and Inverter Information

The following diagnostic information is for the Embraco variable speed compressor.

Note that in cases where a compressor is confirmed to be faulty the inverter should also be replaced. However if an inverter is faulty a working compressor should not be replaced.

### Inverter LED Indication

The LED diagnostics function helps service technicians to diagnose possible component faults by blinking an LED inside the inverter box in different patterns. This indicates if there is a problem with the compressor.

LED Status	Period	Colour	Description
1 Flash	30 seconds	Green	Normal operation
2 Flash	5 seconds	Green	Communication problem
3 Flash	5 seconds	Red	Inverter problem
4 Flash	5 seconds	Orange	Compressor problem
No Flash	-		No input Power/ damaged Inverter

### Trouble Shooting

Compressor does not start	
Problem	Action
Compressor disconnected from the inverter	Verify compressor cable connection and compressor protector plugs
No control signal input or bad connection from controller	Verify control input cable connection and measure the signal from the controller
Open compressor winding	Measure winding for open circuit between all pairs of pins on the hermetic terminal. If any winding is open, compressor is faulty
Compressor with locked rotor (due to mechanical damage)	Replace compressor and inverter
Low input voltage supplied to the inverter	Measure AC voltage to confirm

Problem	Action
Inverter / compressor fault trip	Wait for cooling and reset time of inverter (1 - 10 minutes), Compressor (protector 60 minutes)
Compressor change of noise and or speed	normal function, varies to load according to inverter algorithm

**Compressor** The compressor is located at the front of the refrigeration unit, beside the condenser. If the compressor is causing excessive noise, check the mountings to ensure there is no damage to the rubber or the washers, nuts and screws.

**NOTE**

Variable speed compressor may as normal function rapidly change speed with resulting tonal noise variation.

Before replacing the compressor, check all plug connections and ensure the compressor electrics are operating correctly. The compressor must be supplied with consistent voltage over 220 volts, ensure the voltage does not drop at start-up. If the voltage does drop, ensure the unit has a direct power supply (not from a multi-box or extension cord).



**IMPORTANT**

To eliminate possible vibration noise, ensure condensate pipes are clamped onto base of condensate tray. It is important the compressor discharge pipe is tightly clamped at entry to this tray or high frequency vibration may occur.

The compressor over current protector is located direct on compressor terminals (under the compressor electrics cover). All other electrical is supplied directly from the compressor inverter (located on the opposite side of the unit).



**Compressor** The inverter is a non-serviceable component. For diagnostics see “Inverter  
**Inverter** LED Indication” on page 42.





## 8 Replacement Procedures

### Lighting

The freezer is fitted with LED modular interior lights, and the TMF-AC models are also fitted with an LED modular sign light. Ensure the light is replaced with the same light type. Fluorescent or LED tubes cannot be used in place of LED modular lights.

#### IMPORTANT

Replace the light with the same SKOPE OEM part.  
**DO NOT** use alternative LED strip or tube lights, or fluorescent tubes.

Refer to the table below for replacement light specifications.

#### Light specifications

Model	Interior light		Sign light	
	Description	Part No.	Description	Part No.
TMF650N-A	Interior light	ELL11771	n.a.	n.a.
TMF650N-AC			Sign light	ELL11772
TMF1000N-A			n.a.	n.a.
TMF1000N-AC			Sign light	ELL11773

The lighting is made up of three components which are replaceable:

- LED modular light
- Light power supply (1 per cabinet)
- Interior wiring loom (1 per door)

Power is supplied to the lights by the power supply (located in the cabinet electrics panel above the door/s) via the wiring loom/s which run down the sidelight channel.

Lighting components are all non-serviceable items. If a component is faulty, it should be removed and a SKOPE OEM new replacement component fitted.

Refer to the diagnostics table below to determine what component may be at fault, and the procedures over the next few pages for replacement instructions.

Ensure the cabinet is isolated from the power supply before cleaning or removing parts.

**Lighting fault diagnostics**

Problem	Possible Cause	Repair
No lights working. Cabinet is dark.	Lights switched off	Switch lights on at electronic controller faceplate (see page 9), or the app.
	Controller is in Energy Saving mode	Open the door to bring the controller into Normal mode.
	Controller alarm	Check controller for alarm code.
	Plug not connected properly	Check and clean plugs on top of the cabinet.
	Light power supply fault	Replace light power supply.
Light component not working.	Plug not connected properly	Check and clean plug connection in side light channel, behind the loom cover.
	Faulty light	Replace light.
Segment of light not working.	Faulty light	Replace light.

**To replace an interior light component**

1. Unplug the freezer from the power supply.
2. Unplug the light, and remove the light from the plastic casing.



3. Clip the replacement light into place on the plastic casing, ensuring the male end of the light is at the top, and plug the light in.

4. Ensure the light is firmly and completely clipped in.
5. Reconnect to the power supply and check for correct operation.

### To replace the LED driver power supply

1. Disconnect the freezer from the power supply.
2. Remove the sign panel.

#### IMPORTANT

**Lift the unit, do NOT slide as the cabinet seal may be damaged.**

3. Detach the refrigeration unit and carefully push back or remove to allow access to the cabinet electrics cover.

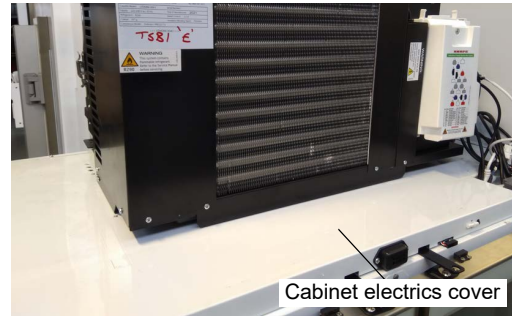

4. Unscrew the cabinet electrics cover.

5. Remove the light power supply.

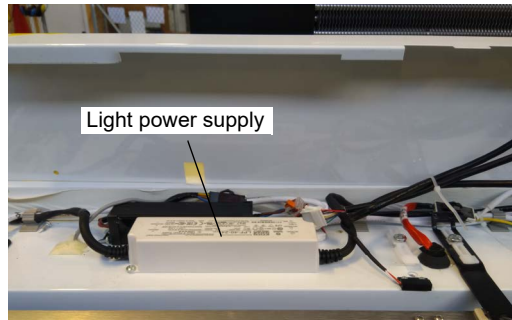

**Check the cabinet top seal is not damaged when refitting the unit. Any seal damage must be replaced. Seal damage may result in ice build up in the unit.**

6. Replace the light power supply and reassemble

### To replace an interior wiring loom

1. Disconnect the freezer from the power supply.
2. Unplug the light from the wire loom.
3. Gain access to the cabinet electrics panel (see procedure above).
4. Move up to the cabinet roof, and unplug the wiring loom from the light power supply, and if applicable the sign light.
5. Remove the putty from the loom entry point on the cabinet roof, and pull the loom up through the cabinet ceiling.
6. Refit the new loom and reassemble. Ensure that:
  - ▣ all plugs are clean, correctly fitted and plugged in.
  - ▣ the ceiling and roof hole is completely sealed with putty.

**Sign Light** The sign is lit by an LED modular light which can be replaced by following the steps below.

**To replace the sign light**

1. Disconnect the freezer from the power supply.
2. Undo the two fixing screws from the sign top cover and remove the top cover.
3. Remove the front sign panel/decals by sliding them up and out of the sign.
4. Remove the sign cover from the top of the sign.
5. Remove additional sign panel by sliding up and out of the sign.
6. Cut the cable tie holding the light cable at the back of the sign.
7. Undo the two most right hand sign reflector screws.
8. Carefully pull the light plug and cable through to the front of the sign, manipulating the reflector as required.
9. Unclip and replace the light.
10. Route the light plug and cable back through behind the reflector and hole at the back of the sign, and cable tie in place.
11. Reassemble the sign, reconnect to the power supply and check for correct operation.

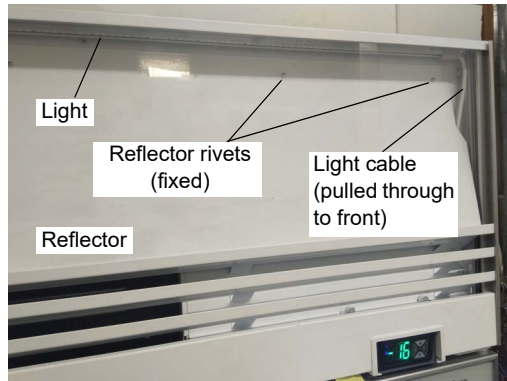

## Doors

---

Door sealing is critical. The gasket must fully seal around the entire cabinet perimeter because any air gaps will form ice inside the freezer cabinet.

**WARNING**  
For safe door operation the door bottom hinge bracket must always be fitted with a split pin.

**Alignment Adjustment** If a door is out of alignment, realign it by loosening the top hinge bracket fixing screws, and move the top of the door as required.

**Height Adjustment** A height adjustment block is fitted below the bottom hinge. As standard, the notched edges on the bottom of the hinge and the top of the height adjustment block align to set the door to the correct level. If the door is not at the correct height when at the standard setting, follow the steps below to adjust the height.

**Note:** The door height cannot be adjusted on solid door cabinets, and on the middle door on three door models.

### To adjust the door height

1. Isolate the freezer from the power supply.

2. Loosen the bottom hinge, and remove the height adjustment block.

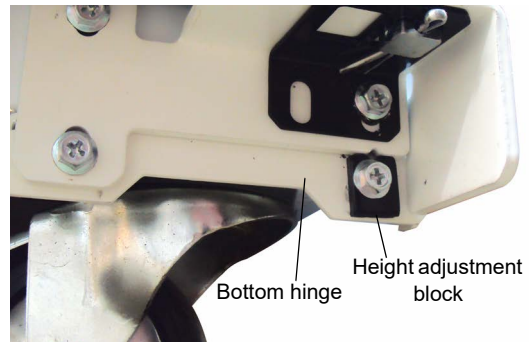

3. Set the door to the correct height, rotate and refit the height adjustment block to the most appropriate setting and tighten up the bottom hinge screws.

**Replacing the Gasket** The one-piece door gasket clips into the door frame and runs around the perimeter of the door. Remove the gasket by peeling it from the door frame, starting at a corner.

If the gasket is out of shape after refitting, use a hair dryer to heat and reshape it.

**Removing and Refitting the Door** For ease of servicing and to reverse the hinging, the door can be removed from the cabinet. Refer to the image below for door hinging components.

### To remove the door

1. Isolate the freezer from the power supply.
2. Remove the sign panel.

*Continued over the page*

3. Remove the split pin from the capstan at the bottom hinge (outside door pictured).

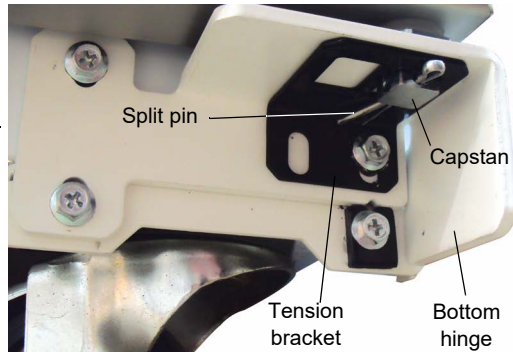

4. Unscrew and remove the tension bracket. Take care when removing as the bracket is under tension.

---

**To replace the top hinge bracket (if necessary)**

---

1. Follow the steps on the previous page to remove the door.
  2. Remove the top hinge from the top of the door and replace.
- 

**To refit the door**

---

1. Lift the door onto the bottom hinge.
2. Fit the top hinge to the top of the door, and partially fix in place on the top of the cabinet. Align the door with the cabinet and tighten the fixing screws.  
Ensure the top hinge spacer is fitted under the top hinge before fixing the top hinge in place.

3. Apply tension to the door (see page 36).

4. Fit the split pin through the hole in the capstan to lock the door in place (outside door pictured).

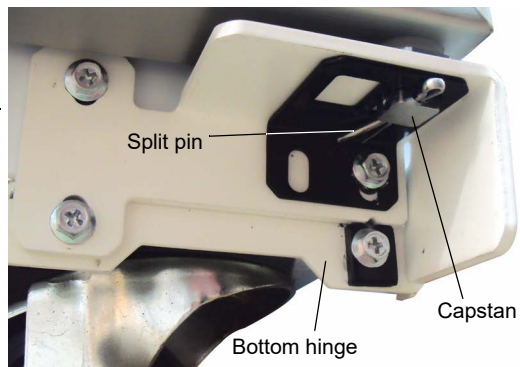

5. Fit the height adjustment block to the bottom screw hole (not fitted to middle doors). As standard, the notched edges on the bottom of the hinge and the top of the height adjustment block align to set the door to the correct level. If necessary, rotate the height adjustment block to level the door.
-

**Adjusting Door Tension** The door has an internal torsion bar, pre-tensioned at the factory, that lets the door self-close. If necessary, the door tension can be further adjusted by rotating the capstan mounted in the bottom hinge bracket.

**To adjust the door tension**

1. Remove the split pin from the capstan at the bottom hinge.
2. Remove the tension bracket from the bottom hinge.

3. Use a tool to apply tension to the door via the capstan. First, rotate the capstan against the door opening direction to remove any slack. Once resistance is felt, continue to rotate 180° to provide tension.

While holding door tension on the capstan, fit the tension bracket to the top screw hole so that it supports the door tension on the capstan.

Outside door pictured.

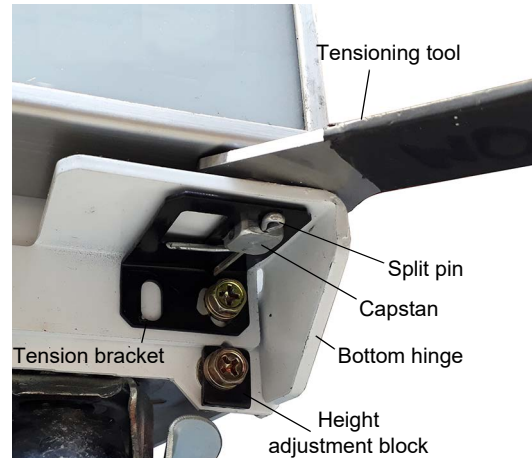

4. Fit the split pin through the hole in the capstan to lock the door in place.

5. Check door tension by holding the door open about 100mm and letting it go. The door should gently close, with the gasket forming an airtight seal with the cabinet.

**Replacing the Torsion Bar** When the door tension can no longer be adjusted, replace the torsion bar.

**To replace the torsion bar**

1. Remove the door from the cabinet (see page 49).

2. Lever the capstan, bush and bush washer from the bottom of the door, and unhook from the torsion bar.

**Note:** The torsion bar cannot easily be removed from the door. Cut the old torsion bar and push it into the door frame.

Fit the capstan, bush and bush washer to the new torsion bar, and fit this assembly into the bottom of the door.

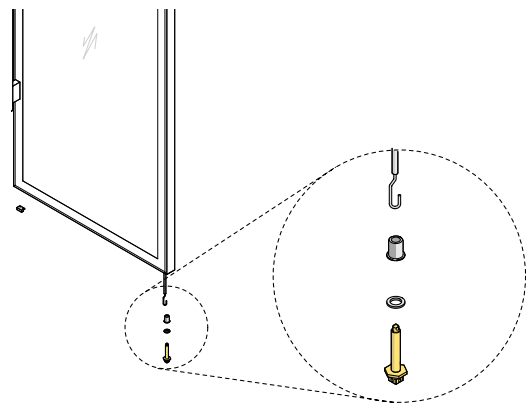

3. Refit the door (see page 49).

## Refrigeration Unit

---

### Before Servicing Overview

Ensure you have read and understand this manual before commencing with any servicing.

**Important.** Ensure the following before servicing:

- ▣ Only technicians contracted to SKOPE hydrocarbon service policy may service this cabinet, according to the Service Tech type.
- ▣ SKOPE hydrocarbon refrigeration systems must only be serviced by appropriately skilled refrigeration mechanics.
- ▣ Servicing of sealed refrigeration system must be completed at a hydrocarbon workshop/service area with dedicated hydrocarbon equipment and personal protective equipment.
- ▣ All local hydrocarbon storage and handling regulations and procedures must be adhered at all times.

Ensure all electronic controller alarms diagnostics and refrigeration system diagnostics are performed to confirm a refrigeration system fault is present. Do **NOT** open the refrigeration system. Check all components such as the electronic controller and electrical systems. If a sealed system fault is suspected, the system must not be opened; it must be checked as “Refrigeration System Diagnostics – Function Test” on page 40

#### IMPORTANT

Use only dedicated hydrocarbon SKOPE OEM spare parts.

**DO NOT** use alternative parts.

For safety compliance, only SKOPE supplied components specified for the appliance shall be used for repairs.

#### Safety hazards

The main hydrocarbon safety hazards are:

- ▣ Flammable refrigerant.
- ▣ Venting of hydrocarbon and compressor oil.
- ▣ Asphyxiation.



#### Refrigerant identification

The cabinet rating label (located in the upper inside of the cabinet) states the refrigerant type. In addition to this, a warning labels are fitted to hydrocarbon refrigeration coolers to indicate the use of R290 refrigerant.

#### Personal Protective Equipment (PPE)

Ensure all required PPE is used correctly during servicing.

#### Service equipment

All refrigeration service tools must be hydrocarbon compliant and any electrical equipment that could be exposed to the refrigerant must be intrinsically safe. **ONLY** dedicated hydrocarbon service equipment may be used.

In addition to standard tools for accessing and removing parts, specialist tools are required when completing refrigeration system service tasks detailed in this manual:

- ▣ Intrinsically safe vacuum pump.



- Dedicated hydrocarbon gauges.
- Intrinsically safe hydrocarbon combustible gas leak detector.
- Intrinsically safe scales to 0.1gm accuracy.
- Well ventilated work area.

**Refrigeration Unit Assembly**

The refrigeration unit is a top mounted, electronically controlled removable unit.

For safety and compliance, only SKOPE supplied parts specifically for this appliance may be used for repairs. Other parts may appear to be suitable, but may not be approved or safe for use in an appliance with hydrocarbon refrigerant.

The unit must only be used on a SKOPE Hydrocarbon compliant cabinet. Refer to the cabinet rating label to determine if the cabinet is suitable for use with a hydrocarbon unit. The rating label MUST state refrigerant as R290. If the label states a different refrigerant, or does NOT state a refrigerant, it is NOT suitable for a hydrocarbon unit.

**WARNING**  
The hydrocarbon unit must only be used on an hydrocarbon compliant cabinet.

For servicing or transportation, the refrigeration unit unplugs and lifts off the cabinet. Some minor servicing can be performed without removing the refrigeration unit.

The model and serial number are both printed on the unit rating/serial number label attached to the top of the side of the cover.

Specifications for the model are in the following table. Verify model and basic requirements before servicing.

**Unit specifications**

Unit Model:	UTHDNI-0043
Compressor:	Embraco VNEU217U
Compressor capacity:	740 Watts
Refrigerant / Charge	R290 / 107 g

**Gas Detector**

A gas detector is required and must be used when servicing HC units. A gas detector is a safety device for Hydrocarbon gas to warn the technician that hazardous flammable gas is present.

**Leak Detector**

A leak detector is recommended for servicing HC units. It is used to track and locate the source of Hydrocarbon gas leaks.

**On-Site Work**

The service technician must have required knowledge, skills and tools to proceed with on-site refrigeration sealed system diagnostics.

**Minimum knowledge and skills**

- Experience and qualifications suitable for work on a flammable refrigeration system as per “Service Tech type”
- Performs no unsafe activity.
- Fully complies with “SKOPE HC Service Requirements” on page 6.

**Minimum tools and equipment**

- Hydrocarbon gas detector
- Safety signage - suitable to create a safe work zone 1.5m around the cabinet.
- Refrigeration gauge set - suitable for R290 flammable refrigerant.

- Bullet valves/line piercing valves suitable for 6mm tube.

#### **Service vehicle**

- Suitable for transporting flammable gas (being HC refrigeration systems). Vehicle storage area must be well ventilated externally, and not ventilated into the vehicle. There must be no ignition sources in the storage area, nor any areas where the gas may pool.
- Must be able to transport swap units.
- Should carry minimum SKOPE HC service parts.

#### **Not Cooling Fault**

If a customer reports a 'not cooling' fault, and it has been established that the cabinet is not cooling, follow the procedure on See "On-site work procedure by authorised service person" on page 73 when making the service visit.

#### **Hydrocarbon Workshop**

The following tools and equipment are required in the hydrocarbon workshop:

- Hydrocarbon leak detector
- Dedicated hazardous workshop area – suitable for servicing and release of flammable refrigerant
- Refrigeration gauge set – suitable for R290 flammable refrigerant
- Dry nitrogen – suitable for purging and high pressure testing
- Refrigeration vacuum pump rated as suitable for use with R290 (by the vacuum pump supplier)
- Charging scales rated as suitable for use with R290 (by the scales supplier), accuracy to 1.0gm
- R290 refrigerant supply cylinder

## Removing the Unit

Follow the steps below to remove the refrigeration unit from the cabinet. Ensure the freezer is disconnected from the power supply before removing the unit.

The unit is heavy (48kg) and requires a minimum of two people to lift from the cabinet. Steps or a platform about one metre high are suggested to allow the unit to be safely lifted, carried and put down at waist height.

### To remove the refrigeration unit

1. Unplug the freezer from the power supply.
2. Remove the top sign. If fitted with key locks, open the door/s and unscrew the sign from the brackets below the sign.
3. Detach the electronic controller assembly from the top of the cabinet, and clip it onto the top of the unit.
4. Remove electrics cover and unplug the mains supply plug and cabinet plugs.
 

**Note:** The unit plugs (plugs feeding into the unit) and electronic controller plugs (plugs feeding to the electronic controller assembly) do not need to be unplugged.
5. Remove the sign back strip. **Note:** If necessary the sign sides can also be removed.
6. Undo the two unit fixing screws (one on each side of the unit) and lift the unit off the cabinet. Replace seal if damaged because any gap may allow cabinet ice build up.
7. When refitting the unit, ensure that the:
  - ▣ the gasket on the top of the cabinet is in good condition.
  - ▣ you take care of cabinet seal, Lift the unit, Do NOT slide unit on seal
  - ▣ the mains and cabinet plugs are reconnected.
  - ▣ the electrics cover is refitted.
  - ▣ the unit is re-fixed in place.

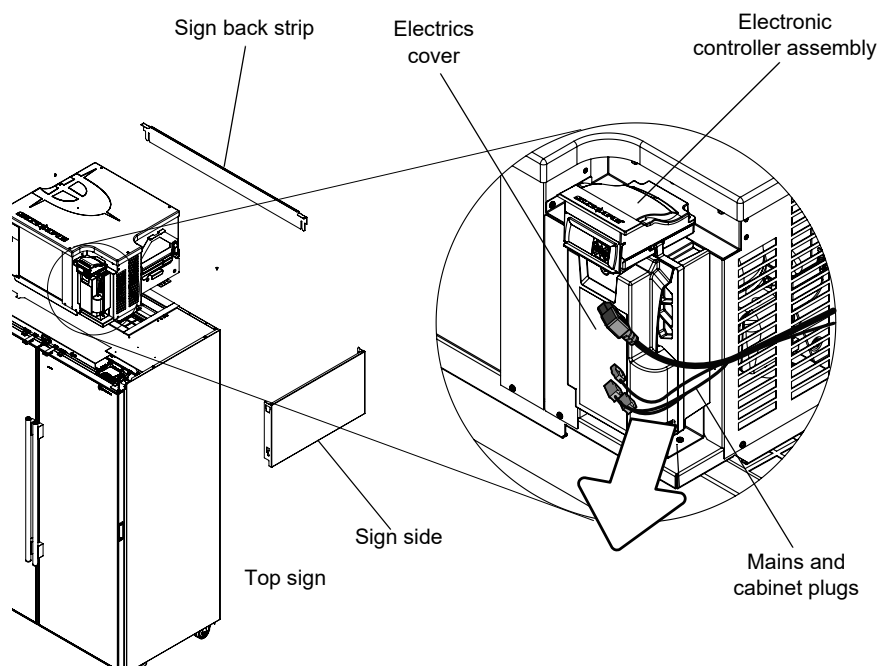

**Replacing the Unit** The SKOPE ActiveCore freezer refrigeration unit can be replaced. Follow the procedure below.

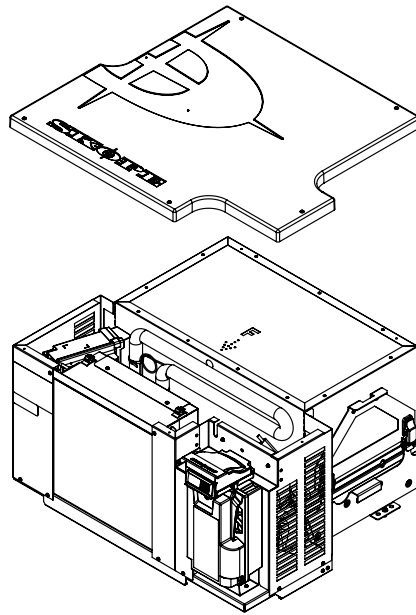

**WARNING**  
The hydrocarbon unit must only be used on a hydrocarbon compliant cabinet.

## Unit Electrics Box Assembly

The unit electrics box assembly contains the mains supply socket, and panel mount socket connectors for the unit and cabinet. Refer to the diagram over the page or label on the electrics box cover for socket connection identification.

Due to the confined space within the unit electrics box, plugs may come loose as a result of movement and vibrations. Take care when refitting to ensure all plugs are securely attached to the correct sockets.



### To remove and open the unit electrics box assembly

1. Disconnect the freezer from the power supply.
2. If present, unclip the electronic controller from the top of the electrics box.

3. Undo the fixing screw at the top of the electrics box cover, and remove the cover.



4. Unplug all unit plugs from the unit electrics box.
5. Undo the two fixing screws at the base of the electrics box, and detach the electrics box from the unit.
6. To open the electrics box, undo the two fixing screws on the back of the electrics box and swing the back cover off.

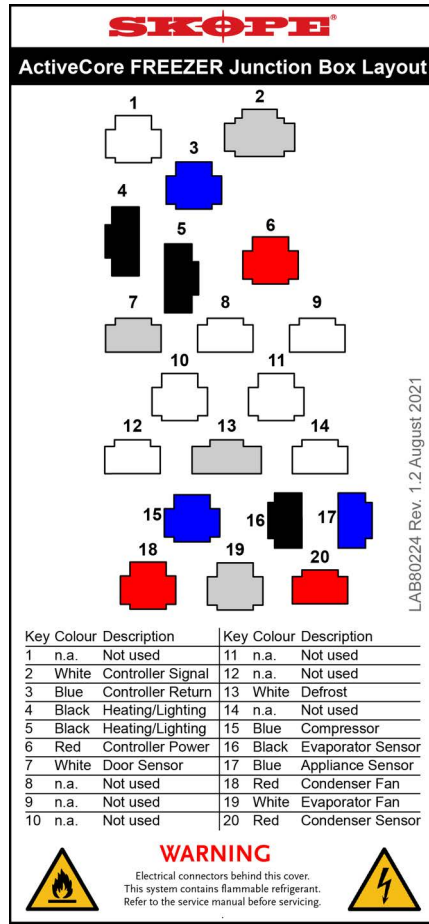

**Unit Cover** Remove the unit cover to access parts within the unit assembly.

**To remove the unit cover**

1. Disconnect the freezer from the power supply and remove the refrigeration unit (see page 55).

2. Unscrew the five screws from the sides of the refrigeration unit and lift the cover off the unit.

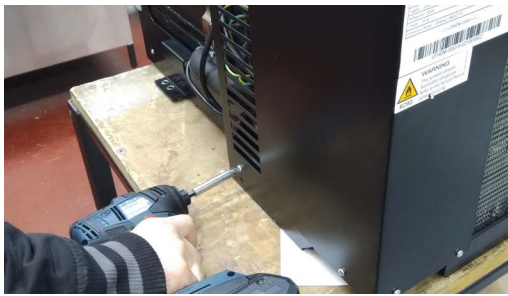

**Condenser Fan** The condenser fan assembly is made up of a fan motor, fan blade and mounting brackets which can be replaced if necessary.

If the fan stops for any reason, check all connections to ensure no plugs have come loose. Refer to the label on the electrics box cover to identify the condenser fan plug and socket in the electrics box.

**IMPORTANT**  
 Replace the motor with the same SKOPE OEM part.  
**DO NOT** use alternative parts.

It is important that the fan blade and/or fan motor is replaced with the same part to ensure safety, correct alignment and refrigeration performance, and compliance. Fan blades should be tightened to the fan motor manufacturer recommended torque settings (shown in the table below).

#### Fan motor manufacturer recommended torque settings

Fan motor manufacturer	Torque setting
Wellington Drive	1.5 Nm

#### To access and remove the condenser fan assembly

1. Isolate the freezer from the power supply and remove the refrigeration unit (see page 55).
2. Remove the unit cover (see page 58).
3. Open the electrics box and unplug the condenser fan motor plug (see page 57).

4. Cut the cable ties holding the cables along the unit, and free up the condenser fan motor cable.



5. Remove the fan assembly (fan motor, fan blade, mounting brackets) from the unit by lifting the shroud up and out.

#### To replace the fan blade

1. Remove the condenser fan assembly (see above).
2. Remove the screw and washer from the centre of the fan blade, and lift the blade from the motor.
3. Replace new blade and fix with 12mm flat washer and serrated head screw. Tighten the blade to fan motor manufacturer recommended torque setting.
4. Reassemble unit and test.

#### To replace the fan motor (with correct SKOPE spare part only)

1. Remove the condenser fan assembly and the fan blade (see above).
2. Unplug the fan flexible cord from the electrics box (see page 57).
3. Detach the fan motor from the fan mounting brackets by removing the four screws from the mounting bracket.
4. Fit new motor and reattach fan blade with 12mm flat washer and serrated head screw. Tighten the blade to 1.5Nm. Ensure motor connection plug is orientated to be at the top when fitted.
5. Reassemble unit, ensuring all cables are neatly cable tied away from the fan blade, and test for correct operation.



**Evaporator Fan** The evaporator fan assembly is made up of a fan motor and fan blade, both of which can be replaced when necessary. The evaporator fan flexible cord has a white plug.

If the fan stops for any reason, check all connections to ensure no plugs have come loose. Refer to the label on the electrics box cover to identify the evaporator fan plug and socket in the electrics box.

The fan motor and fan blade are fixed to the evaporator shroud via the brackets. The shroud (complete with fan motor and fan blade) can be lifted off the evaporator tub once the refrigeration unit cover and evaporator box top has been removed.

**IMPORTANT**  
 Replace the motor with the same SKOPE OEM part.  
**DO NOT** use alternative parts.

It is important that the fan blade and/or fan motor is replaced with the same part to ensure safety, correct alignment and refrigeration performance, and compliance. Fan blades should be tightened to the fan motor manufacturer recommended torque settings (shown in the table below).

**Fan motor manufacturer recommended torque settings**

Fan motor manufacturer	Torque setting
Wellington Drive	1.5 N m

**To access the evaporator fan assembly**

1. Isolate the freezer from the power supply and remove the refrigeration unit (see page 55).

---

2. Unclip and remove the foamed top.

---

3. Remove the refrigeration unit cover.

---

4. Free up cables from the putty on the evaporator box top perimeter has been removed.

---

5. Cut cable ties to release control probe from the fan bracket.

---

6. Lift the assembly up and out of the evaporator box.



**To replace the fan blade**

1. Isolate the freezer from the power supply and remove the refrigeration unit (see page 55).

---

2. Gain access to the evaporator fan assembly (see above).

---

3. Remove the screw and washer from the centre of the fan blade, and lift the blade from the motor.

---

4. Fit new blade, ensuring it is centred within the evaporator shroud. Tighten the blade to fan motor manufacturer recommended torque setting.

---

5. Reassemble unit and test for correct operation.

---



**To replace the fan motor (with correct SKOPE spare part only)**

---

1. Follow the above steps to access the evaporator fan assembly and remove the fan blade.

---
2. Free the fan flexible cord by cutting the cable ties, trace the cable back to the connector (near the compressor electrics) and unplug.

---
3. Detach the fan motor from the fan mounting brackets by removing the four screws from the mounting bracket.

---
4. Attach to the replacement motor. Ensure that the flexible cord points towards the bottom of the evaporator tub once reinstalled. Take care to re-cable tie the fan and temperature probe flexible cords back onto the mounting bracket (to prevent high frequency vibration).

---
5. Fit fan blade, ensuring it is centred within the evaporator shroud. Tighten the blade to 1.5Nm.

---
6. Reassemble unit and test for correct operation.

---

---

## Replacing the Controller

Follow the steps below to replace the controller.

**Note:** Replacement spare part electronic controllers are not supplied with the parameter set loaded. This must be loaded via the SCS Connect Field app after replacing the controller. Internet access may be required.

### To replace the controller

1. Disconnect the freezer from the power supply and access the electronic controller (see page 8).
2. Remove the cable clamps and disconnect the terminals from the back of the controller.

3. Fit the new replacement controller, and connect up the terminals at the back of the controller. Fit low voltage terminals before high voltage terminals.

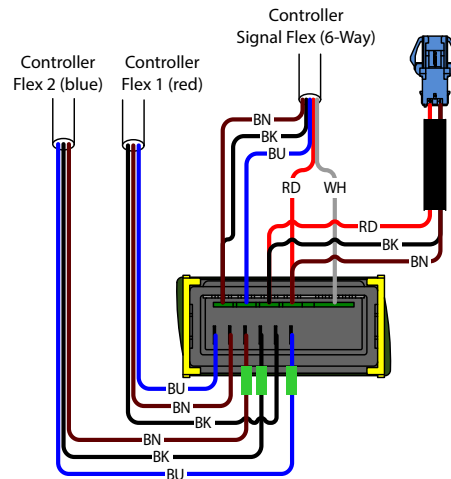

4. Reassemble the controller box and cabinet, perform electrical safety test as required, and reconnect to the power supply.
5. Use a mobile device to connect to the controller with the SCS Connect Field app (see "SCS Connect Field App and Track App" on page 11).
6. Navigate to the LOAD PARAMETER FILE menu.
7. Select the appropriate parameter file from LOCAL. If not available in LOCAL, search for the parameter file in SERVER (internet access required), and download to LOCAL.
8. Confirm correct file and WRITE TO SCS.
9. After WRITE TO SCS is complete, select MENU DISCONNECT to save parameter set on SCS.
10. Power cycle the controller and check that correct parameter set has been applied
11. Power cycle the controller and check that correct parameter set has been applied
12. Set up controller and cabinet links as required:

#### Corporate

The service tech must link to the controller to the cabinet serial number in the SCS Connect Field app.

#### General Market

The owner must set up SKOPE-connect (if in use).

**Door Switch** The freezer is fitted with a door switch above each door, which tells the electronic controller when a door is opened. A small magnet in the door frame activates the switch. A cable connects the switch to the electronic controller via an inline connector on top of the cabinet.

---

**To remove the door switch**

---

1. Disconnect the freezer from the power supply.
  2. Disconnect the door switch cable plug from the inline connector on top of the cabinet.
  3. Unscrew the two fixing screws from the door switch and remove.
  4. Fit the replacement door switch and connect via the inline connector.
- 
- 

**Control Probe** The control probe is cable tied to a bracket sitting in the return air port, in front of the evaporator coil (see image below).

---

**To replace the control probe**

---

1. Remove the evaporator fan assembly (see page 60).
  2. Detach the probe from the evaporator fan shroud bracket and trace the probe cable back to the unit electric box and unplug (see page 56).
  3. Following the same path as the original probe, fit the new probe with cable ties as necessary. Ensure the probe cable is securely plugged into the rear of the unit junction box, and that it is cable tied to the evaporator fan shroud bracket, with the probe positioned in a vertical 90° angle.
- 
- 

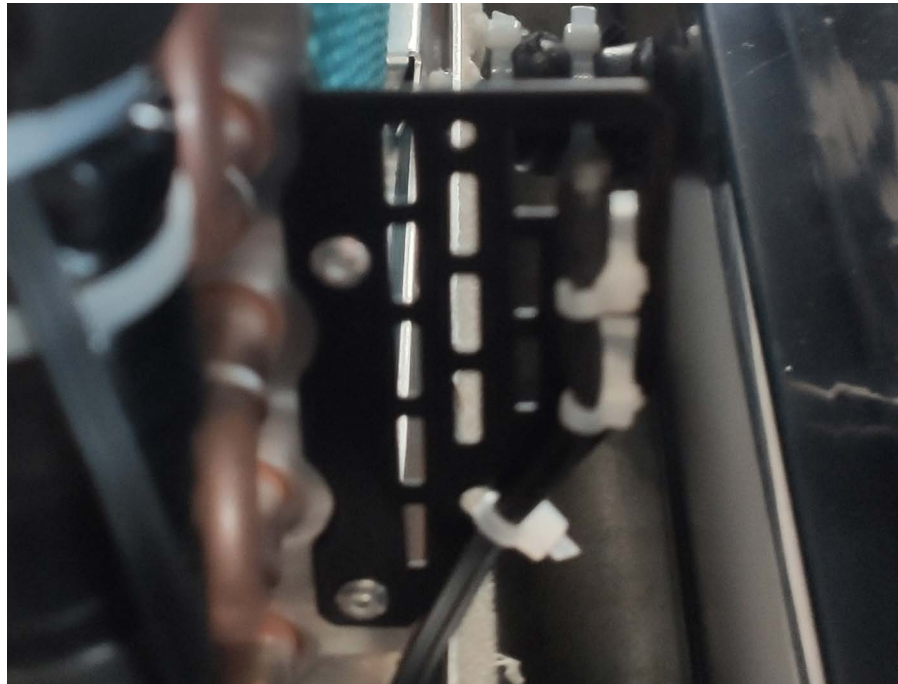

**Evaporator Probe** The evaporator probe location and its insulation onto the evaporator outlet pipe is critical to reliable function of hot gas defrost and evaporator fan motor function.



**To replace the evaporator probe**

1. Disconnect the freezer from the power supply and remove the refrigeration unit (see page 55).
2. Remove the unit cover (see page 58).
3. Remove the evaporator fan assembly (see page 60).

4. Remove both pieces of putty securing the pipes and cables on the evaporator tub perimeter.

5. Carefully lift the coil up and out of the evaporator tub. Take care of pipes and cables when lifting out.



6. Detach the probe from the side of the evaporator coil, and trace the probe cable back to the unit electric box, cutting cable ties as required, and unplug (see page 56).

7. Following the same path as the original probe, run the new probe to the evaporator coil and secure with cable ties. Position the probe in the same location as the original probe (against the side of the coil above the bottom pipe as pictured above). Plug the probe cable securely into the electric box.

8. Reassemble the unit and test for correct operation.

**IMPORTANT**  
Ensure that the evaporator probe is fully insulated with cork tape when it is replaced.

**Condenser Probe** The condenser probe is located on the side of the condenser coil. It monitors condenser temperature and protects compressor from overheating.

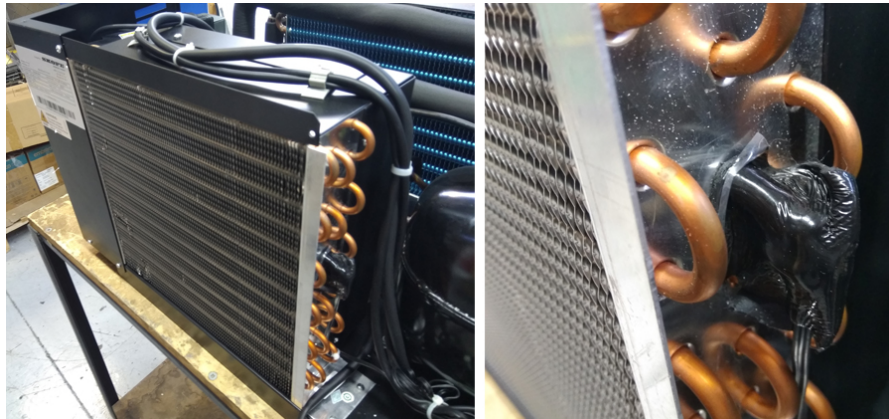

#### To replace the condenser probe

1. Disconnect the freezer from the power supply and remove the refrigeration unit (see page 55).
2. Remove the top cover, junction box and EMI filter assembly.
3. Detach the probe from the side of the condenser coil, and trace the probe cable back to the unit electrics box, cutting cable ties as required, and unplug (see page 56).
4. Following the same path as the original probe, run the new probe to the condenser coil and secure with cable ties. Locate the probe in the same location as the original probe (as pictured above) and insulate with cork tape. Plug the probe cable securely into the electrics box.
5. Reassemble the unit and test for correct operation.

**Ambient Probe** The ambient probe is located above the door. It monitors the temperature around the refrigeration unit. **Note:** The ambient probe is wired in series with the door switch.

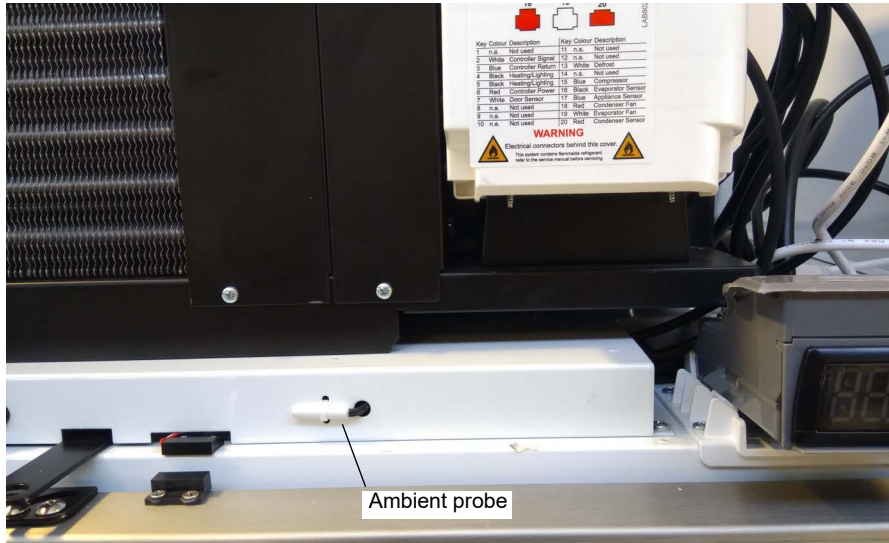

Ambient probe

**To replace the ambient probe**

1. Disconnect the freezer from the power supply.
2. Remove the sign panel.

3. Detach the refrigeration unit and carefully push back or remove to allow access to the cabinet electrics cover.



Cabinet electrics cover

4. Unscrew the cabinet electrics cover.
5. Detach the probe from the electrics cover, and trace the probe cable back to the connector, cutting cable ties as required, and unplug.
6. Fit the new probe and secure with cable ties. Ensure the probe is located in the same location as the original probe (as pictured above).
7. Reassemble the unit and test for correct operation.



## Replacing Component Notes

The following refers to replacing the compressor and inverter, and any sealed component (evaporator coil/condenser coil).



- A faulty inverter does not require an operational compressor to be replaced
- When replacing a compressor, the inverter and compressor protector should also be replaced.
- When replacing a compressor the drier must be replaced.
- The compressor and drier must not be left open to air (the maximum time allowed is less than 20 minutes).
- OFN (oxygen free nitrogen) service purging must be applied at all times when brazing.
- To prove gas tightness a high pressure drop of 1500Kpa OFN (only) should be applied for more than 12 hours.
- Evacuate to less than 10 Pa for more than 4 hours.
- Charge to +/- 1 gm of refrigerant charge on label.
- Braze process tubes closed (service valves must not be left on long term).
- Leak test the entire system as final check to confirm that no leaks are present.

## Cleaning

Before any cleaning, unplug the cabinet from the power supply.

**Cabinet** Wipe the inside and outside of the cabinet with a damp cloth, taking care to keep moisture away from electrical parts.

**Condenser Coil** To ensure trouble-free performance, the condenser coil must be kept clean. We strongly urge monthly cleaning with a soft brush to remove dust and fluff. A more thorough cleaning is required by qualified service personnel every six months. The condenser coil **must** be kept clean for efficient and reliable operation.

### WARNING

Unplug the cabinet from the power supply before cleaning the condenser coil.

### To clean the condenser coil and optional condenser filter

1. Isolate the freezer from the power supply.

2. Remove the front panel from the top of the cabinet by swinging it out and off. Lit sign front panels will also need to be unplugged.

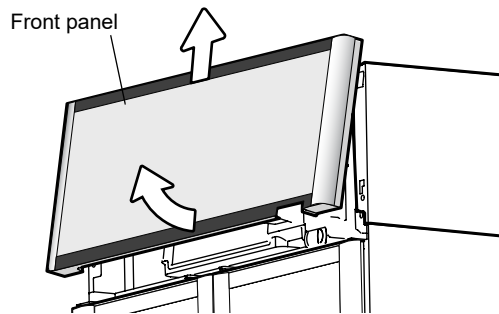

**WARNING: The front panel is heavy, a two person lift is recommended.**

3. Brush the condenser coil with a soft brush to remove any dust and fluff.

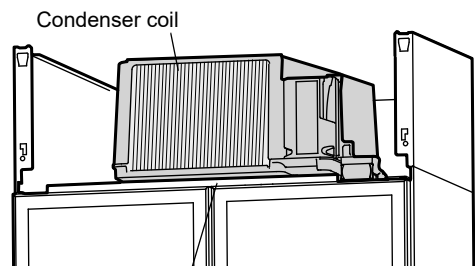

4. Refit the sign panel and reconnect to the power supply.

#### Important

When refitting, ensure the tabs on the back of the sign are placed in the notches on top of the cabinet, and that the sign is pushed fully in and secure.

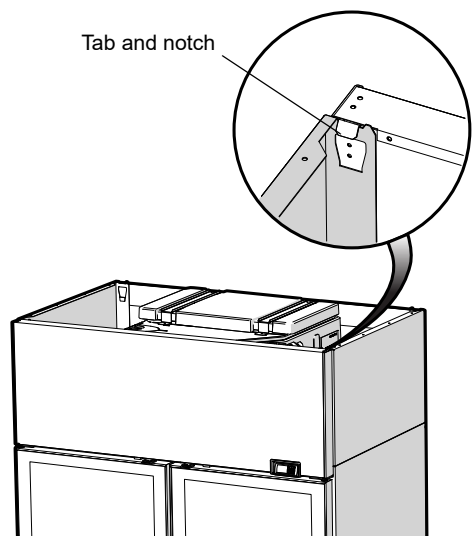



Probe Resistance

Product specification  
产品技术规格

规格型号(PART NO.)	APR-CWF103F3435FB3000B
文件编号(FILE NO.)	APR-CWF9573A
版本(EDITION)	A/2

MF58D R25=10.000K Ω ±1% B25/85= 3435K 料号: BT07D 版本: A							
T(°C)	Rmin(K Ω)	Rnom(K Ω)	Rmax(K Ω)	T(°C)	Rmin(K Ω)	Rnom(K Ω)	Rmax(K Ω)
-40	202.879	211.276	219.999	-3	31.143	31.824	32.516
-39	191.348	199.150	207.250	-2	29.784	30.422	31.069
-38	180.601	187.855	195.381	-1	28.492	29.089	29.695
-37	170.571	177.320	184.317	0	27.264	27.823	28.390
-36	161.198	167.481	173.991	1	26.097	26.620	27.150
-35	152.430	158.281	164.340	2	24.986	25.475	25.972
-34	144.217	149.669	155.312	3	23.929	24.387	24.852
-33	136.518	141.601	146.858	4	22.923	23.352	23.787
-32	129.293	134.033	138.933	5	21.966	22.367	22.774
-31	122.508	126.930	131.499	6	21.055	21.430	21.810
-30	116.130	120.257	124.518	7	20.187	20.538	20.893
-29	110.131	113.983	117.959	8	19.360	19.688	20.020
-28	104.484	108.081	111.792	9	18.572	18.879	19.189
-27	99.164	102.525	105.988	10	17.821	18.108	18.398
-26	94.151	97.291	100.525	11	17.105	17.373	17.644
-25	89.424	92.358	95.378	12	16.422	16.673	16.926
-24	84.963	87.706	90.527	13	15.770	16.005	16.241
-23	80.753	83.316	85.953	14	15.149	15.368	15.588
-22	76.777	79.174	81.637	15	14.556	14.760	14.966
-21	73.020	75.261	77.564	16	13.989	14.180	14.372
-20	69.469	71.565	73.717	17	13.449	13.627	13.806
-19	66.111	68.072	70.084	18	12.932	13.098	13.265
-18	62.935	64.769	66.651	19	12.439	12.593	12.749
-17	59.929	61.646	63.405	20	11.967	12.111	12.256
-16	57.084	58.690	60.336	21	11.516	11.650	11.785
-15	54.391	55.894	57.432	22	11.085	11.210	11.335
-14	51.839	53.246	54.685	23	10.672	10.788	10.905
-13	49.422	50.738	52.085	24	10.278	10.386	10.493
-12	47.131	48.363	49.623	25	9.900	10.000	10.100
-11	44.959	46.113	47.291	26	9.531	9.631	9.731
-10	42.899	43.979	45.082	27	9.178	9.278	9.378
-9	40.946	41.957	42.989	28	8.841	8.940	9.039
-8	39.093	40.039	41.004	29	8.517	8.616	8.715
-7	37.334	38.220	39.123	30	8.207	8.306	8.404
-6	35.664	36.494	37.339	31	7.911	8.008	8.106
-5	34.079	34.856	35.647	32	7.626	7.723	7.821
-4	32.573	33.301	34.041	33	7.354	7.450	7.546

Shenzhen AMPRON Sensitive Components Co.,Ltd.  
TEL:86-755-84012223 84012259 FAX:86-755-84012280

Http://www.ampron.com  
E-mail:sales@ampron.com

Probe Resistance (continued)

Product specification  
产品技术规格

规格型号(PART NO.)	APR-CWF103F3435FB3000B
文件编号(FILE NO.)	APR-CWF9573A
版本(EDITION)	A/2

MF58D R25=10.000KΩ±1% B25/85= 3435K 料号: BT07D 版本: A							
T(°C)	Rmin(KΩ)	Rnom(KΩ)	Rmax(KΩ)	T(°C)	Rmin(KΩ)	Rnom(KΩ)	Rmax(KΩ)
34	7.092	7.188	7.283	71	2.103	2.157	2.212
35	6.841	6.936	7.031	72	2.041	2.095	2.149
36	6.601	6.694	6.789	73	1.982	2.034	2.088
37	6.370	6.463	6.556	74	1.925	1.976	2.029
38	6.148	6.240	6.332	75	1.870	1.920	1.972
39	5.936	6.026	6.117	76	1.816	1.866	1.916
40	5.731	5.820	5.911	77	1.765	1.813	1.863
41	5.535	5.623	5.712	78	1.715	1.763	1.811
42	5.346	5.433	5.521	79	1.667	1.714	1.762
43	5.164	5.250	5.337	80	1.620	1.666	1.713
44	4.990	5.075	5.160	81	1.575	1.620	1.667
45	4.822	4.906	4.990	82	1.532	1.576	1.621
46	4.660	4.743	4.826	83	1.489	1.533	1.578
47	4.505	4.586	4.668	84	1.449	1.492	1.535
48	4.355	4.435	4.516	85	1.409	1.451	1.494
49	4.211	4.290	4.370	86	1.371	1.412	1.455
50	4.072	4.150	4.228	87	1.334	1.375	1.416
51	3.939	4.016	4.093	88	1.298	1.338	1.379
52	3.811	3.886	3.962	89	1.264	1.303	1.343
53	3.688	3.762	3.837	90	1.230	1.269	1.308
54	3.569	3.642	3.716	91	1.198	1.235	1.274
55	3.455	3.526	3.599	92	1.166	1.203	1.241
56	3.345	3.415	3.487	93	1.136	1.172	1.209
57	3.239	3.308	3.378	94	1.106	1.142	1.179
58	3.137	3.205	3.274	95	1.078	1.113	1.149
59	3.039	3.106	3.174	96	1.050	1.084	1.120
60	2.944	3.010	3.077	97	1.023	1.057	1.092
61	2.853	2.918	2.983	98	0.997	1.030	1.064
62	2.765	2.829	2.893	99	0.971	1.004	1.038
63	2.681	2.743	2.806	100	0.947	0.979	1.012
64	2.599	2.660	2.723	101	0.923	0.955	0.987
65	2.520	2.580	2.642	102	0.900	0.931	0.963
66	2.444	2.503	2.564	103	0.878	0.908	0.939
67	2.371	2.429	2.488	104	0.856	0.886	0.916
68	2.300	2.357	2.416	105	0.835	0.864	0.894
69	2.232	2.288	2.345				
70	2.166	2.221	2.278				

## 9 Troubleshooting

### Electronic Controller

Alarms signal unexpected operational changes in the cooler. When an alarm is activated, use the electronic controller app to assist with fault diagnosis and service as necessary. See page 11 for information.

### Cabinet and Refrigeration Unit

For problems with the cabinet and refrigeration unit use the following table.

Problem	Possible Cause	Repair
<ul style="list-style-type: none"> <li>• Cabinet not operating</li> <li>• No controller display</li> </ul>	<ul style="list-style-type: none"> <li>• Loss of power supply</li> <li>• Loose plug in electrics box</li> </ul>	<ul style="list-style-type: none"> <li>• Check mains power supply.</li> <li>• Check all plugs in electrics box are connected correctly.</li> </ul>
<ul style="list-style-type: none"> <li>• Sign and/or Interior lights not on.</li> </ul>	<ul style="list-style-type: none"> <li>• Electronic controller is in 'Night' mode</li> <li>• Light switched off</li> <li>• Electronic controller displays alarm indicating a refrigeration system error</li> <li>• Failed LED light</li> </ul>	<ul style="list-style-type: none"> <li>• Switch the light on while keeping the freezer in night mode by pressing the light button on the electronic controller faceplate.</li> <li>• Change the freezer into 'Day' mode by pressing and holding the Day-Night button on the electronic controller faceplate, or hold the door open for 10 seconds.</li> <li>• Switch light on via button on the electronic controller faceplate.</li> <li>• Diagnose and repair. If system fault found, contact SKOPE for how to proceed.</li> <li>• Service light.</li> </ul>
<ul style="list-style-type: none"> <li>• Excess noise vibration</li> </ul>	<ul style="list-style-type: none"> <li>• Refrigeration pipes transferring vibration into unit</li> </ul>	<ul style="list-style-type: none"> <li>• Noise variation is usual as compressor speed changes.</li> <li>• In the case of excess noise, check discharge pipes are securely clamped to base of condensate tray, and check no refrigeration pipes are touching other pipes or share edges.</li> </ul>

*Continued over the page*

<ul style="list-style-type: none"> <li>• Frozen evaporator coil</li> </ul>	<ul style="list-style-type: none"> <li>• Evaporator probe fault</li> </ul>	<ul style="list-style-type: none"> <li>• Check and replace evaporator probe.</li> </ul>
	<ul style="list-style-type: none"> <li>• Controller fault</li> </ul>	<ul style="list-style-type: none"> <li>• Replace controller.</li> </ul>
	<ul style="list-style-type: none"> <li>• Short of refrigerant</li> </ul>	<ul style="list-style-type: none"> <li>• Perform refrigeration system diagnostics (see page 40) and service as required.</li> </ul>
<ul style="list-style-type: none"> <li>• Ice build inside evaporator box</li> </ul>	<ul style="list-style-type: none"> <li>• leaking unit seal</li> </ul>	<ul style="list-style-type: none"> <li>• Check evaporator tub seals are fully clamped, and cabinet top seal is good without gaps. Micro-gaps will allow ice build in freezer.</li> </ul>
<ul style="list-style-type: none"> <li>• Power consumption is higher than expected</li> </ul>	<ul style="list-style-type: none"> <li>• Unit operating too hot</li> <li>• Cabinet door is opened excessively</li> <li>• Product too cold</li> </ul>	<ul style="list-style-type: none"> <li>• Clean the condenser.</li> <li>• Ensure the cabinet has good ventilation around the refrigeration unit.</li> <li>• Ensure the cabinet is within the maximum operating temperature.</li> <li>• Ensure door is closed more often.</li> <li>• Raise set point</li> </ul>
<ul style="list-style-type: none"> <li>• Product is too warm.</li> <li>• Cabinet is overstocked. Product must not overhang the shelves, and must remain below load limit label.</li> </ul>	<ul style="list-style-type: none"> <li>• Frequent door opening</li> <li>• Recently loaded</li> <li>• Door not closing properly</li> <li>• Refrigeration unit operating too hot</li> <li>• Excessive door opening or refrigeration heat load</li> <li>• Set point is too high</li> </ul>	<ul style="list-style-type: none"> <li>• Limit door openings.</li> <li>• Allow time for the product to freeze.</li> <li>• Check and clean door gasket.</li> <li>• Ensure the cabinet has good ventilation around the refrigeration unit.</li> <li>• Ensure the cabinet is within the maximum operating conditions.</li> <li>• Lower the set point.</li> </ul>
<ul style="list-style-type: none"> <li>• Moisture build up on door or exterior.</li> </ul>	<ul style="list-style-type: none"> <li>• High humidity</li> <li>• Frequent door opening</li> <li>• Door not closing properly</li> </ul>	<ul style="list-style-type: none"> <li>• Check the ambient operating temperature and reposition the freezer if necessary.</li> <li>• Limit door openings.</li> <li>• Check and clean door gasket.</li> </ul>
<ul style="list-style-type: none"> <li>• freezer door does not shut properly.</li> </ul>	<ul style="list-style-type: none"> <li>• freezer is on an uneven surface</li> <li>• Door is obstructed</li> </ul>	<ul style="list-style-type: none"> <li>• Level the freezer.</li> <li>• Check shelves and product.</li> </ul>
<ul style="list-style-type: none"> <li>• Warm cabinet temperatures</li> <li>• Compressor operating for long periods (more than 1 hour)</li> </ul>	<ul style="list-style-type: none"> <li>• Blocked condenser</li> <li>• Poor ventilation around refrigeration unit</li> <li>• With inverter it is normal for compressor to run for long periods at a low speed to overall conserve energy</li> </ul>	<ul style="list-style-type: none"> <li>• Clean the condenser.</li> <li>• Ensure the cabinet has good ventilation around the refrigeration unit.</li> <li>• Ensure the cabinet is within the maximum operating temperature.</li> </ul>

### On-site work procedure by authorised service person

If a customer reports a 'not cooling' fault, and it has been established that the cabinet is not cooling, follow the procedure below when making the service visit.

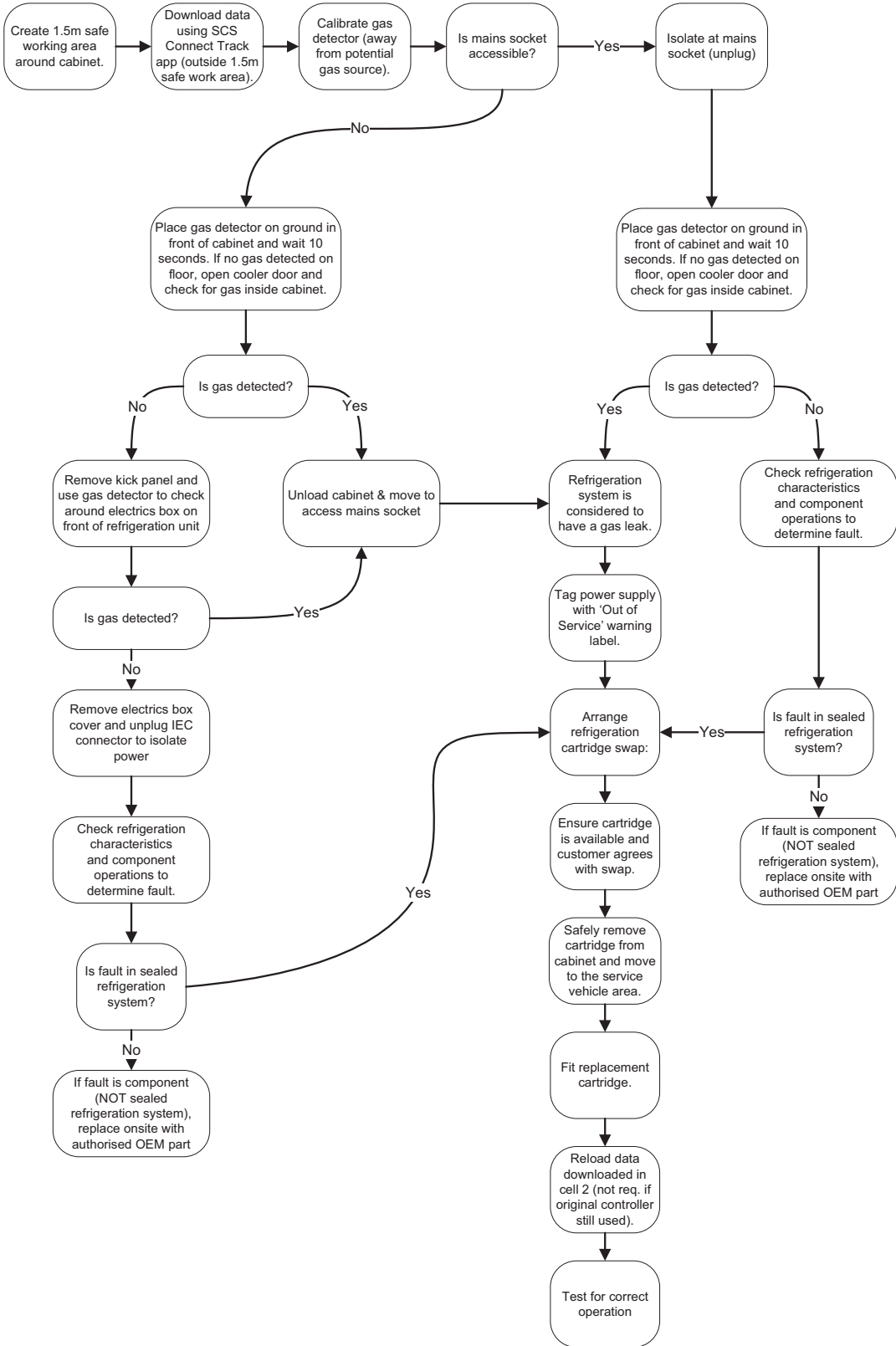

### On-site work procedure (continued)

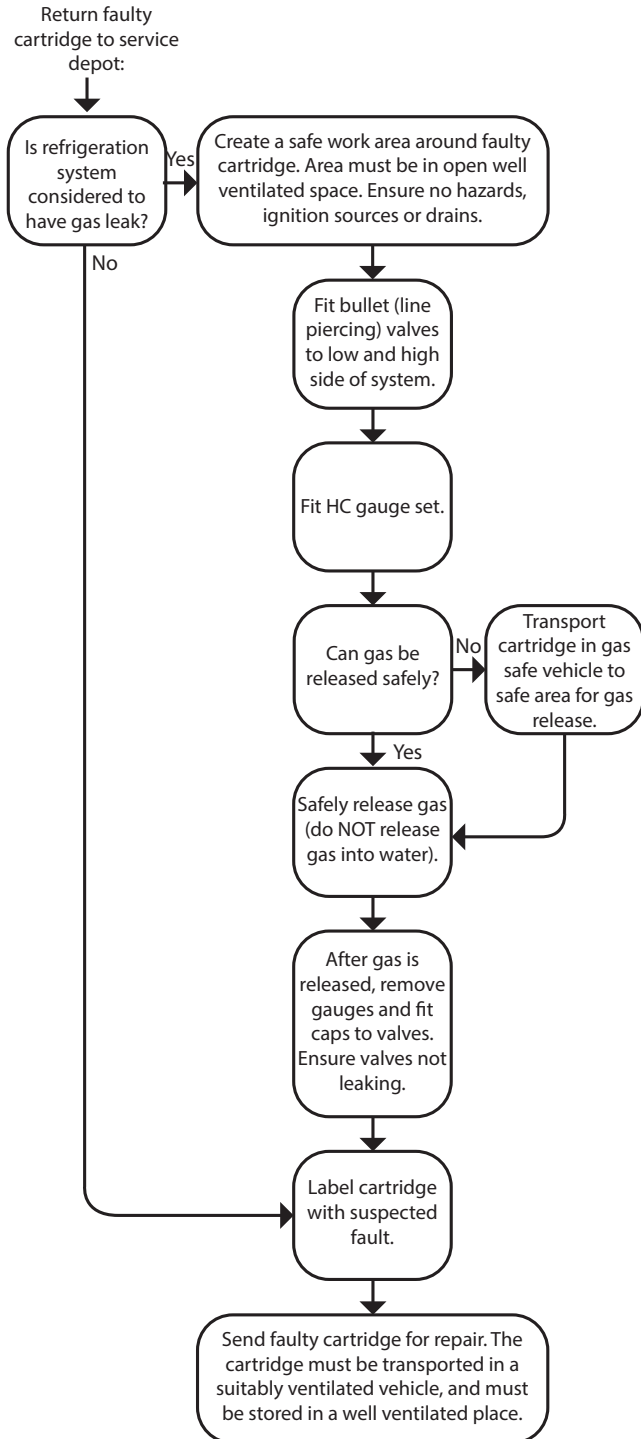

# SKOPE Contacts

---

## SKOPE Industries Limited

ABN: 73 374 418 306

AU: 1800 121 535

NZ: 0800 947 5673

[skope@skope.com](mailto:skope@skope.com)

[www.skope.com](http://www.skope.com)