

Accessories & Spare Parts



GUARDIAN[®] TAPWARE

Dual Hob Mount Tap Body



T-3M63134

- Full S/S construction
- Dual hob tap body includes inlet hoses
- ½ turn rising spindles
- Inlet hoses have ½" FI BSP loose nut and tail
- ¾" FI BSP riser connection
- Working pressure range 150 - 500kPa
- Maximum hot water temperature - 80°C

Front

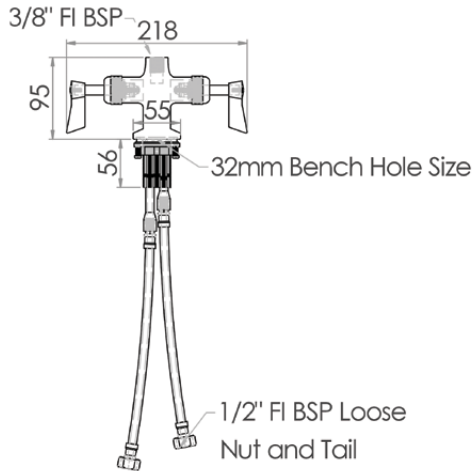

Top



Side

