

HUSSMANN®



Reference: IM-1007P_SGN141S-1

The following models are covered by this Manual
SGN141S-1

66 Glendenning Road, Glendenning NSW 2761
PO Box 42 Doonside NSW 2767
t: +61 2 8805 0400 f: +61 2 9675 2897

SGN141S-1 Self Contained R290 Low Height Open Medium Temperature Refrigerated Display Cabinet Installation & Maintenance Manual

CONTENTS

Pre-Installation / For Your Safety	_____	3
Servicing, Maintenance and Refrigerant Handling	_	4 - 5
Receiving Cabinets	_____	5
Moving Cabinets into position	_____	6
	Cabinet Cross-section & Footprint	7
	Technical Data Sheet	8
	Operating Environment	9
	Installed Position	9
	Key Operation Points	10
Installation	_____	
	Electrical installation	11-12
	Cabinet Operation / Start-up	12
Cabinet Operation	_____	
	Load Limits	12
	Fittings and Accessories	12
	Temperature adjustment	13
Maintenance	_____	
	Cleaning	13 - 14
	Regular Inspection	15 – 21
	Trouble Shooting	21 – 23
	Risk Analysis	24 – 25
	Start-up Checklist	25 - 26
	End-of-Life decommissioning of the Cabinet	27
Appendices	A/. Wiring Diagram	28



Pre-Installation

Caution !! Read the content of this manual before installation and use of the equipment

Consider this Installation & Maintenance Manual as integral part of the equipment.

Ensure that the Manual is available to the personnel who will be using the cabinet and/or carrying out any maintenance operation(s) on it.

In case of resale ensure that the Manual is passed on to the subsequent owners.

Keep the Manual in good conditions for the whole life of the equipment, and ensure its content remains undamaged. In case of loss or damage to the manual, ask for a replacement copy.

Installation shall be in areas with a volume greater than 15m³ per SGN141S-1 cabinet, and a floor area greater than 6.8m².



FOR YOUR SAFETY

Cabinet utilises flammable refrigerant R290 (Propane) with a 142-gram charge quantity. Identified by specific labels. The Type of refrigerant (R290) is also specified in the serial/rating plate.

End-users and service personnel are required to fully understand and observe the following instructions.

Each and every operator, as well as the maintenance personnel, must carefully read and fully understand or have these instructions explained before using this equipment.

Warning!! This appliance is not intended to be used by persons (including children) with reduced physical, sensory or mental capabilities, or lack of experience and knowledge, unless they have been given supervision or instruction concerning use of the appliance by a person responsible for their safety. Children shall not play with the appliance.

Warning!! Do not damage the refrigerant circuit.

Warning!! Do not keep explosive substances such as aerosol cans with a flammable propellant inside the equipment.

Warning!! Do not use mechanical devices or other means to speed up the defrost process unless those (if any) expressly permitted by the manufacturer.

Warning!! Do not use electric appliances inside the cabinet's display area unless those (if any) expressly permitted by the manufacturer.

Warning!! Keep clear of obstruction all ventilation openings in the appliance enclosure.

Do not exceed the load limits of display decks and shelves.

Warning!! If the power supply cord or the power plug is damaged, it must be replaced by the manufacturer, their service agent or a suitably qualified persons in order to avoid any hazard.

SERVICING, MAINTENANCE AND REFRIGERANT HANDLING

1. R290 is classified as **flammable refrigerant** of Class A3 according to ANSI/ASHRAE. It is a highly flammable and very easy to ignite. It can burn with explosive impacts.
2. R290 in contact with air can cause a risk of fire or explosion in presence of **open flames** or **sparks** generated by electrical equipment.
3. R290 (Propane) has no odour. Take extra cautions if a leak is suspected i.e. quarantine the cabinet and call for a qualified refrigeration service technician to attend.
4. Servicing can be only performed by **qualified personnel** holding a valid certificate and competence to work on and break into a R290 refrigeration circuit safely.
5. Service intervention must be carried out considering the mentioned above risk: **do not use electric tools and open flames.**
6. Components which require substitution: - only use **original spare parts** for they have been specifically approved for use with R290 (Propane) refrigerant.
7. The refrigerant circuit is hermetically sealed (closed loop) therefore refrigerant filling, draining or substitution of some components is **not possible without breaking the vacuum.**
In such a case:
 - i. the substitution **cannot be performed indoors** at the customer's premises.
 - ii. the cabinet should be **moved to a controlled workshop environment** suitable for the type of repair where work can be conducted safely.
 - iii. In any case, work in **confined spaces must be avoided.** Work area can be in the open or, alternatively, must be properly ventilated. Ventilation should be able to safely disperse any released refrigerant and expel it safely externally to the atmosphere.
8. While working on cabinet with R290 during which the refrigerant can be possibly released to the surrounding space, all possible **ignition sources**, including cigarette smoking, must be at least 10 metres away from the place of installation, maintenance or disposal.
9. In case hot work is required (welding, brazing) **best practice must always be applied.** This should require the following procedure to avoid risk of fire or explosion.
 - i. remove refrigerant safely
 - ii. purge the circuit (with inert gas)
 - iii. evacuate
 - iv. purge again with inert gas
 - v. open the circuit by cutting (or brazing)
 - vi. Operator must be properly skilled and authorized to perform hot works on systems working with flammable refrigerants.
10. In order to reduce flammability hazards the installation of this appliance must only be carried out by a suitably qualified person.
11. Always use appropriate Personal Protection (PPE) i.e. gloves, safety glasses, boots or shoes, long pants, long-sleeve shirt, etc.

12. Take extra caution with Anti-static protection when undertaking any electrical and/or controller work.

Receiving Cabinets

Cabinets will always be dispatched in good condition. Always inspect the cabinet and packaged accessories for damage. Note any damage on the carrier's consignment note prior to signing.

For concealed damage that is found later, notify Hussmann in the relevant country within 3 working days. Any issues will be addressed and rectified as applicable.

Australia: Hussmann Australia Pty Ltd
Email: warranty_au@hussmann.com
Phone: +61 2 805 0400

New Zealand: McAlpine Hussmann Ltd
Email: taurangasales@hussmann.com
Phone: +64 7 578 0965

Prior to installation Cabinets must be stored protected from the weather and at temperatures and humidity's within 0°C ~ +45°CDB / 30% ~ 80%RH.



NOTE: - Please provide a photographic record of any damage found along with the cabinet serial number and a brief description of the damage.

NOTE: - Any shortages will follow the same procedure as concealed damage.

A check should also be made to ensure that all loose parts listed on the outside packaging are present and undamaged.

Moving Cabinets to Installed Position



To ensure any risk of damage to cabinets while moving to their installed location is minimised, it is strongly recommended that the following instructions are followed.

Equipment Required:

1 x Suitably sized Pallet Truck or Fork hoist.

NOTE: - the SGN141S-1 cabinet is fitted with castors for final positioning, please take care as wheels can be difficult to steer and/or may run freely on slight gradients. This is a minimum 2-person task.

Once cabinets have been moved into the store with the shipping pallets** still attached, the following methods should be used to move cabinets to their final installed position:

1. Carefully lift the cabinet off the pallet with a fork hoist or pallet truck, taking care to position the forks in the centre of the cabinet and directly under the skid rails. Test for stability / centre-of-gravity balance before making final movements.
2. Ensure the mounting feet bolts are screwed-up, such that the wheels can be utilised when cabinet is lowered to the floor. Gently lower the cabinet on to the shop floor.
3. Ensure the floor where the cabinet is to be manoeuvred, is swept and free from debris, as this could otherwise result in a roller wheel coming to an abrupt stop and destabilise the cabinet.
4. Once cabinet is in the required position, screw all four (4) feet bolts down into position evenly such that all four (4) feet bolts take the full load of the cabinet and the roller wheels have between 5mm ~ 10mm free space from the floor.
5. *Ensure the cabinet is securely positioned and levelled via a spirit / laser / or theodolite level.*
6. *These Cabinets draw store ambient air in through the Condenser coil located at the bottom of the cabinet. Do not block either air entry or exit areas of the cabinet. NOTE: - the top air exit should have at least a 1.0m clear area and height above the cabinet to allow correct airflow and dissipation.*
7. If the cabinet has been tilted during positioning/installation, wait at least three (3) hours before starting in order to allow any potential oil displacement to settle.



****Timber (pallet only) and plywood (box only) used for shipping materials and they are heat treated (pallet only) and can be recycled**

Cross Sections, Footprints, Load Limits and Data Sheets

SGN141S-1 Medium Temperature Self Contained R290 Low Height Open Refrigerated Display Cabinet

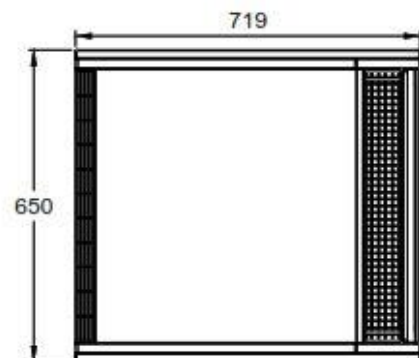
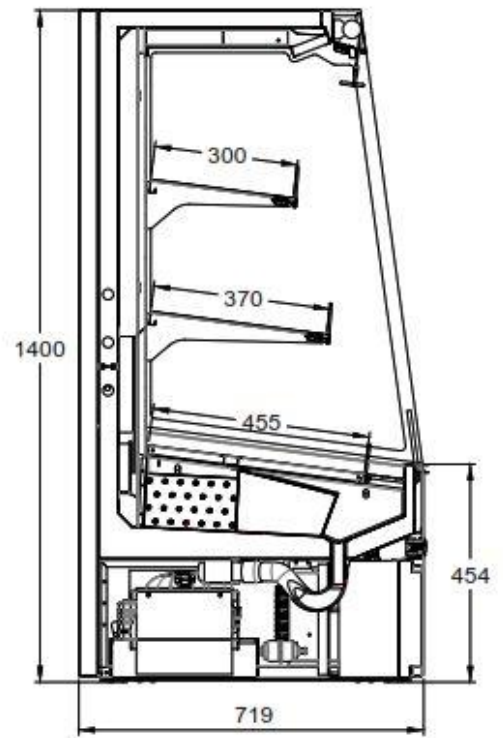
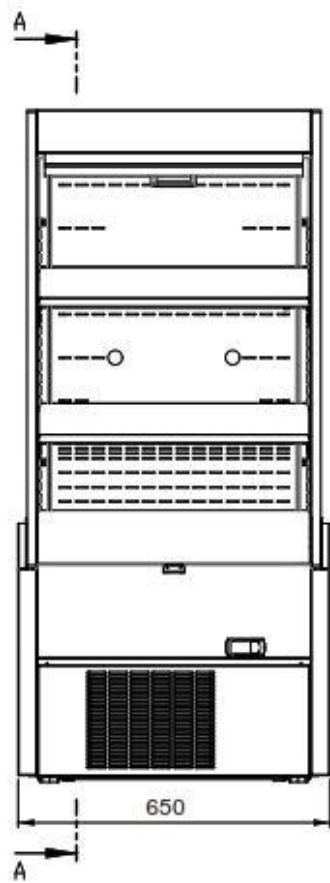

SGN141S-1 DRINK CHILLER CASE							
Refrigeration Settings [AS1731 per Climate Class 3 (+25°C/60%RH)]							
Basic				Case temperature control options			
Product Temperature Class	3M1			⁽²⁾ Cabinet control regulation is per evaporator coil inlet mounted sensor. Cut-Out / Cut-In (regulation band), °C		0.0 / +6.0	
Refrigerant / Expansion device	R290/Capillary						
Defrost – #/day x minutes (failsafe)	8 x 25						
Superheat, K	~ 5						
Refrigeration Rating (Φ_{24-def} per AS1731, Test 1, Climate Class 3)							
Cabinet model (size, mm length overall incl. ends at 40mm each)				SGN141S-1 (650)			
Φ_{24-def} – single cabinet system, Watts (For condensing unit selection purpose)				781			
R290 Refrigerant Charge, grams				142			
Electrical Data (220V AC 50Hz)							
Evap. Fan	Qty x Wattage – Case air flow			1 x 25			
	Total Fan Load, Amps			0.12			
Lights LED	Qty x Wattage - Canopy			1 x 7			
	Qty x Wattage - Shelves			2 x 5			
	Total amps (LED Adapter) max.			0.09			
Unit	Condensing unit (Model)			Embraco EMX6210U			
	Rated Load, Amp			2.4			
Heater	Wattage – Pan heater			Nil (passive)			
	Total Heaters, amps			-			
Cabinet	Total load, amps.			2.6			
Cabinet Energy Consumption & Efficiency Data (AS1731, Product Class 3M1)							
Test ⁽¹⁾	Case Size	Cabinet Type	DEC kWh/d	REC kWh/d	TEC kWh/d	TDA, m ²	TEC/TDA kWh/d/m ²
1 st Test	SGN141S-1	IVC1	7.680	N/A	7.680	0.553	13.886
GEMS EEI registered values (AS1731, Product class 3M1)							
MEPS Reg No.	Case Size	Cabinet Type	DEC kWh/d	REC kWh/d	TEC kWh/d	TDA, m ²	TEC/TDA kWh/d/m ²
ARC0709	SGN141S-1	IVC1	7.680	N/A	7.680	0.553	13.886

(1) Tests for cabinet fitted with night cover are as per AS1731. Test is with night cover (blind) discarded (up) and lights on for entire 24-hour test. 2nd Test is with night cover (blind) applied (down) for 12 hours while lights are turned off and 12 hours night blinds up and lights on within the 24-hour test.

(2) Appropriate adjustments to the refrigeration setting parameters may be required to suit actual store conditions if they vary from Climate Class 3.

Operating Environment

This Medium Temperature Self Contained R290 Low Height Open Refrigerated Display Cabinet has been designed to operate in the following conditions:

Class 3M1 :-

Ambient temperature	+25°CDB
Relative humidity	60%
Max. cross draft	0.2 m/sec
Product Temperature	-1.0°C to +5.0°C

Ambient conditions greater than those stated may result in poorer performance of the cabinet and higher running costs.

Installed Position

The Cabinet(s) should be sited so that external influences are minimized. Situations to avoid are:

Air draughts from:

- Air conditioning,
- Ventilation,
- Heating outlets,
- Entranceways,

Heat sources:

- Sunlight,
- Spotlights,
- Hot cabinets
- Concentrated external lighting,
- Non-insulated roofs and walls,

Mechanical damage:

- Shopping trolleys,
- Forklift trucks,
- Pallet jacks,
- Floor polishers,



CAUTION: -

Any of the above situations could prevent the cabinet(s) from performing correctly.

Extra consideration may be required to minimize the risk of damage.

Refrigerated Cabinet Key Operation Points

- Do not overload the cabinet with product. Merchandised Product layer should be within the shelf and base and loaded to a height within 25mm ~50mm of the next shelf or top panel above for best performance.
- Do not block air delivery honeycomb or air return grille.
- Do not use mechanical devices or other means to accelerate the defrosting process, other than those recommended by the manufacturer.
- Do not use electrical appliances inside the food storage compartments of the appliance, unless they are of the type recommended by the manufacturer.
- Always clean cabinets as described in the cleaning section of this manual.
- During store closed periods it is recommend using the night blind which will achieve a substantial energy reduction.
- This cabinet appliance cannot be used by children or people who are not properly trained.
- The refrigerant charge is factory set and should not be tampered with. Warranty may be voided should this occur.
- The cabinet controller is also factory set. Do not make any controller adjustments without first consulting Hussmann.



NOTE

If a liquid spill should occur, the spill should be cleaned as soon as practicable. Some liquids can be acetic, and if left will risk damage to some components in the cabinet.



NOTE

The SGN141S-1 is a self-contained cabinet with a limited water dissipator tray. When cleaning use minimal water (maximum 1 litres) and carefully observe the water tray in the lower section of the cabinet to prevent excessive water use/overflow.



CAUTION

Do not use electrical appliances inside the food storage compartments of the appliance, unless they are recommended by the manufacturer.



CAUTION

Do not use mechanical devices or other means to accelerate the defrosting process, other than those recommended by the manufacturer.

Electrical Installation

The electrical installation shall:

- Meet existing regulations and safety codes.
- Have an electrical supply to the cabinet that is independent of other supplies and have its' own dedicated fixed power supply/socket. Extension cords and multi-plug socket boards must not be used.
- Be individually isolated.



CAUTION

Location of this cabinet should also take into account the effect it will have on its surrounding environment.

Keep away from storage equipment and products that may be affected by a rise in ambient temperatures

- An electrical diagram will be attached to the electrical enclosure on every cabinet.



NOTE

Cabinets shall be installed level front to back and side to side to allow correct operation and allow condensate water post-defrost to drain freely.



NOTE

Information in this manual is to be followed in conjunction with: - specifications / work practices and requirements of the customer / installing company and relevant industry Standards and Territorial and Government Regulations.



CAUTION

Do not use electrical appliances inside the food storage compartments of the appliance, unless they are recommended by the manufacturer.

Temperature Adjustment

The SGN141S-1 Refrigerated Cabinets are Factory set and should not require any adjustment.

Should for any reason an adjustment be deemed required, only appropriately qualified and trained Service Technicians should undertake this work and should contact Hussmann prior to any changes being considered.



NOTE: - If you require a replacement electrical diagram, please contact the Hussmann help desk.

Please supply the cabinet serial number with the request.

MAINTENANCE

To ensure this range of cabinets maintain food products at the correct temperature, the following information should be followed.

Starting up (by appropriately qualified person)

Check power supply is ready and correct Voltage (230V ~ 240V) and all fans are clear of packaging and all shelves and panels are correctly fitted.

Turn cabinet power on.

Check that all fans and lights are working correctly. Cabinet refrigeration system will take a few minutes to commence cooling, observe operation and ensure cabinet pulls temperature down and cycles between its cut-out and cut-in temperatures. Cabinet temperature is displayed in the lower section via an LED display from the cabinet's microprocessor controller.

Allow the Cabinet to operate for minimum 3 hours before loading with product.



WARNING: - Keep the air vents (front and top) clear of any obstructions.

Load Limits

These cabinets have a load limit that ensures food products stored within these load limits are properly refrigerated. Food products stored outside these load limits may not be properly refrigerated and disturb the airflow with the result that cabinet performance is compromised, and food products may be damaged. NOTE: - merchandise should be pre-chilled to below +5°C prior to placement in the cabinet.

Internal Fittings and Accessories

Only fittings and accessories approved by the manufacturer should be used. Any other additions to the cabinet to not work in its intended fashion.

Cleaning

To maximize efficiency and durability, it is suggested that you effect an appropriate cleaning and maintenance program.

Wear appropriate PPE when cleaning or maintaining cabinet to prevent scratches or splashes (i.e. gloves, safety glasses, etc.).

Galvanized steel (painted) is used inside the cabinet and **it is not rustproof**, particularly in the harsh environment of Food Display cabinets. Chlorine and bromine, commonly used for sanitisation are highly caustic chemicals for stainless steel, in heat and humidity, the corrosiveness of these chemicals is enhanced.

Regular cleaning is the best way to prevent corrosion and add to the service life for your stainless-steel product. The goal of your cleaning and maintenance program should be to keep the stainless steel's protective chromium oxide layer intact. This is what prevents corrosion.

For internal cleaning use:

- Warm water (Less than 55°C)
- Water based cleaning solutions
- Soft cloths

Do not use:

- Abrasive products
- Solvent based products
- Steam or high-pressure water systems

When cleaning:

- Check drain trap is clear of obstructions.
- **Do not** flood the base of the cabinet or well area as water may overflow the small volume water tray in the bottom section of the cabinet onto the floor creating a slipping hazard. **The SGN141-S is a self-contained cabinet with a limited water dissipator tray, when cleaning use minimal water (maximum 1 litres) and carefully observe the water tray in the lower section of the cabinet to prevent excessive water use/overflow.**

Cleaning Acrylic/Perspex (front display)

Clean with a non-abrasive soap (or detergent) and luke-warm water, using a soft grit free cloth, sponge or chamois.

Wipe the Acrylic/Perspex dry with a clean damp chamois or clean soft cloth such as a cotton flannel. Do not use hard, rough cloths or paper towels, as they will scratch the acrylic

Waxing Acrylic/Perspex (front display)

Once the Acrylic/Perspex is clean, minor scratches can be removed using a good grade commercial wax. The wax should be applied in a thin coat and brought to a high polish by rubbing lightly with a dry clean soft cloth, such as a cotton flannel. Do not rub excessively as this may build up a charge that will attract dust to the surface. Blotting with a clean damp cloth is recommended to remove charge.

Cleaning Glass Surfaces (ends)

- Use Domestic glass cleaning fluid, Ammonia based glass cleaner may be used.

- Spray fluid onto a cloth then wipe the glass in a circular motion.

Painted Surfaces

- Use a soft cloth.
- Do not use solvent based cleaning products.
- Always rinse internal surfaces with warm water and allow to dry before re-starting the refrigeration system.

Evaporator Coil

- Never use sharp objects around evaporator coils to de-ice them.
- If the coil has solid ice formed. This indicates the refrigeration and/or defrost cycle are not set correctly. Contact your refrigeration service provider to investigate.
- Use warm water to de-ice coil if required, but not so much as to flood the well/condensate tray in the lower section of the cabinet.
- Use a soft brush or vacuum brush to clean coil. Use PPE (gloves, safety glasses, etc.)
- Do not bend fins.

Condenser Coil

- Never use sharp objects around condenser coil.
- Clean the condenser coil with a soft brush or a vacuum cleaner. The dust and fluff obstruct good air circulation and reduces cabinet performance and increases energy consumption. To reach the condenser coil, remove the protection grille, clean it very carefully (avoid touching other components) and put the grill back in its place.
- Use PPE (gloves, safety glasses, etc.).
- Do not bend fins.



WARNING: - Always isolate cabinet from the mains power supply before deep cleaning.

WARNING: - Keep water away from electrical components.

Regular Inspection

To ensure reliability of the cabinet and leak tightness of the refrigerant circuit, it is advisable that trained personnel carry out periodic maintenance.

Case should be cleaned and inspected by store staff on a daily basis.

- If an alarm system is not part of the refrigeration installation, the temperature of each case should be checked on a daily basis.
- The case discharge air temperature should be within the following ranges of $-4^{\circ}\text{C} \sim +1^{\circ}\text{C}$, unless on defrost.
 - If it is consistently outside the above temperature ranges, contact your service provider.
- Visually check the case for damage or spills and take appropriate remedial action.

Cleaning

- **Do not use hot water on cold glass surfaces as the glass may shatter and cause serious injury.**
- **When flushing the waste drain, do not use high-pressure water hoses and be careful not to introduce water faster than the waste outlet/drain can drain it. This SGN141S-1 cabinet does not have a floor drain. Do not bucket more than 1 litres into the case during cleaning.**



CAUTION: - Do not climb in or on the cabinet as this may result in personal injury and/or case damage.

1. Remove stock from the case and store below $+5^{\circ}\text{C}$.
2. Turn off power to the case (electrical).
3. Remove all price tickets and any foreign materials from the case. Particularly the air return grille / base liner / and defrost tray.
4. Remove shelves and clean with a sponge, warm water and mild detergent, then rinse and wipe dry.
5. Remove the base trays, wash with mild soapy water and rinse.
6. Carefully flush the waste drain with a small amount of water (less than 2 litres) and allow the base to drain. NOTE: - monitor the condensate tray levels in the lower section of the cabinet.
7. Clean the drain area with a soft brush and warm water.
8. Clean the inside of the case (paying particular attention to the perforations in the rear panels) with a clean soft cloth, warm water and mild detergent.
9. Clean glass or mirrored surfaces with a clean soft cloth and mild glass cleaner.
10. Wipe LED lamps with a dry cloth (ensure lights are powered off).

11. Clean bumpers and any plastic parts with a soft cloth and mild detergent, then wipe dry with a clean cloth.

Replace base trays and shelves and turn on power.

13. Allow the case to attain correct working temperature (approx. 30 minutes) and restock the shelves.

NOTE: After cleaning, make sure to clean the area around the case to prevent slips and falls

Monthly

A thorough condenser air filter check, and clean if dirty, should be carried out monthly by store personnel. If condenser air filter is dirty, then the following procedures should be undertaken as a minimum:-

1. The front lower panel holding the condenser air filter is held in position magnetically, it is easy to remove by pulling this panel forward. Refer to photo sequence inserted further below. NOTE:- no tools are required to remove or replace the condenser air filter panel or filter.
2. Use appropriate PPE.
3. Make area safe, ideally this task should be undertaken when the store is closed to customers and undergoing cleaning and/or re-stocking.
4. Remove condenser air filter panel.
5. Remove condenser air filter media/mesh.
6. Take to the back-of-house or an area where filter media/mesh can be undertaken appropriately.
7. If available use a vacuum cleaner with a soft brush and thoroughly clean the filter.
8. If no vacuum cleaner, then washing in warm water is recommended. Ensure the filter is at least shaken dry (i.e. no water drips).
9. Return now clean filter to the cabinet and replace in reverse order. Ensure filter media/mesh is correctly positioned and that the filter panel is re-fitted in its correct position.
10. Photo sequence of above steps in task order follows:-

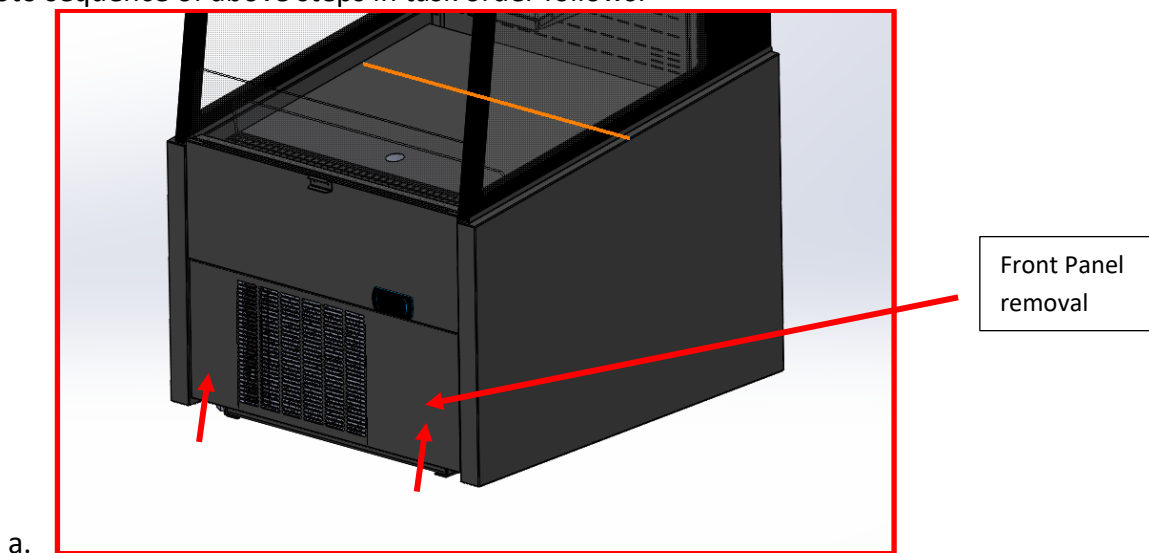

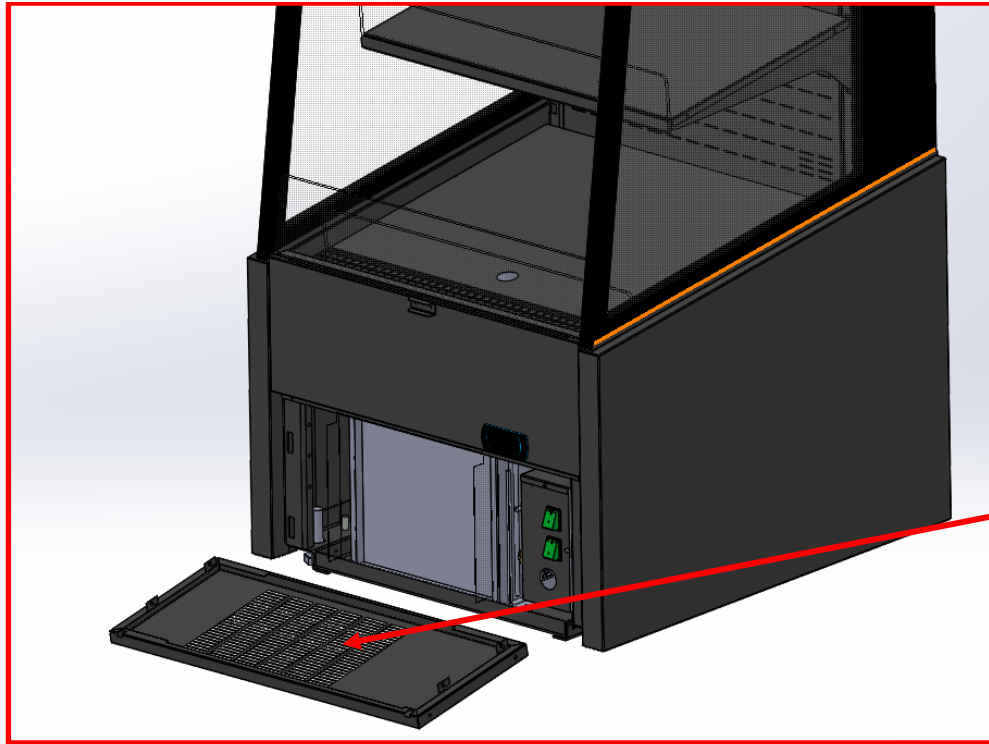

Condenser
Filter
Media/Mesh

b.

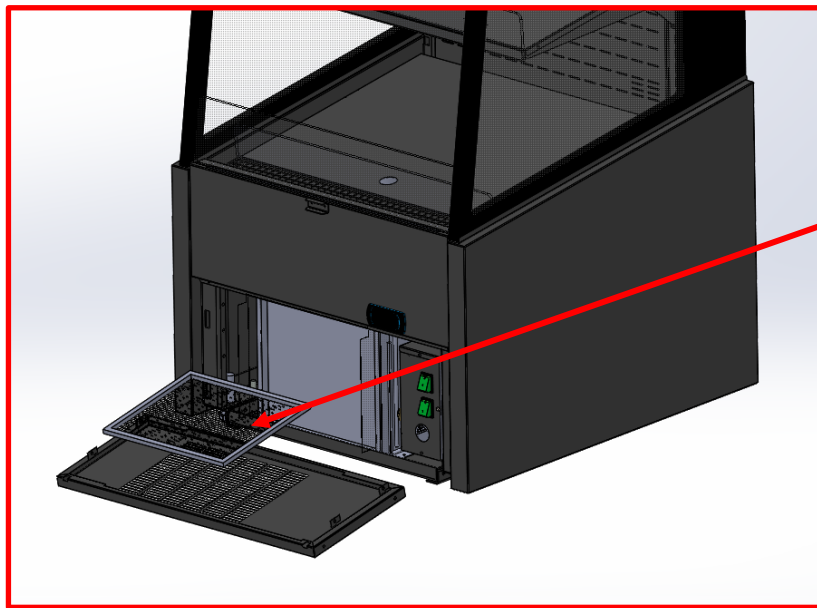

Condenser Filter
Media/Mesh
(removed and fully
cleaned)

c.

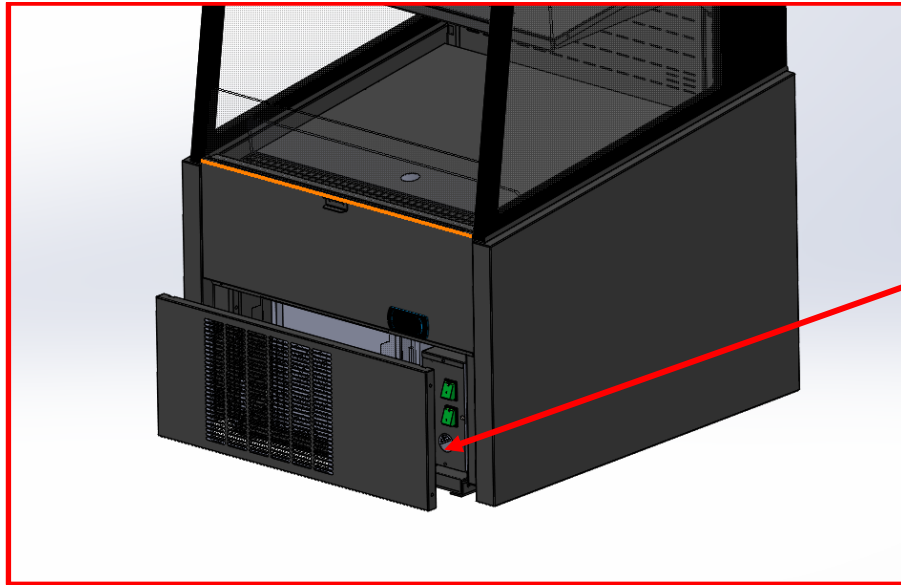

Cleaned condenser filter media/mesh placed back into the condenser air filter panel

d.

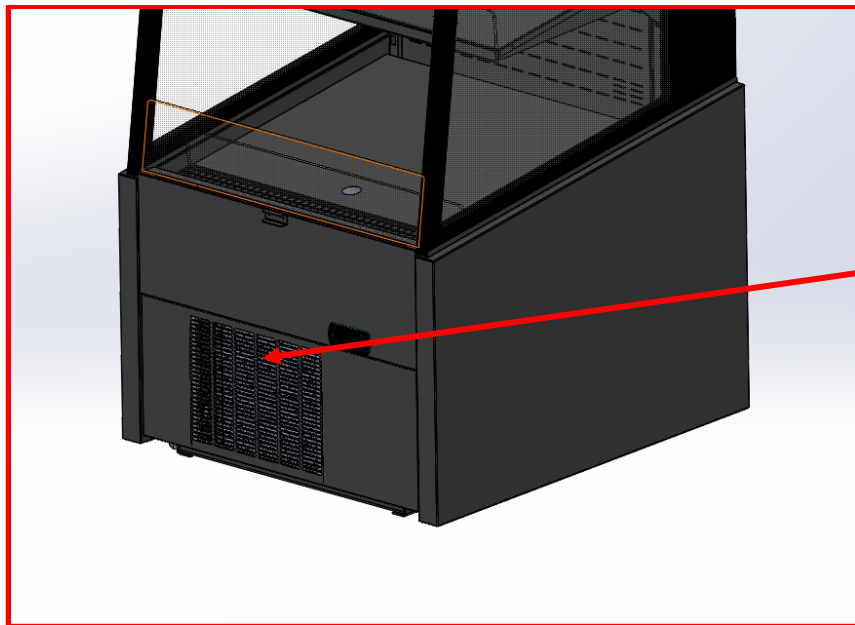

Fix front panel on its location back after cleaning is done

e.

Six-monthly

A thorough cleaning of the Condenser Air Filter and Condenser Coil, and maintenance check should be carried out on a six-monthly basis by a qualified and approved refrigeration engineer. The following procedures should be undertaken as a minimum:-

Cleaning (Six-monthly)

1. Clean the condenser coil air filter by careful washing. If necessary, also clean the condenser coil itself with a soft brush or a vacuum cleaner. Dust and fluff obstruct good air circulation and reduces cabinet performance and increases energy consumption. To reach the condenser air filter and condenser coil, remove the front grill panel, remove the air filter, and clean carefully (avoid touching other components). Put the air filter and front grill panel back in place.
2. Ensure the air filter once cleaned is replaced in the same position (adjacent to the air-on face of the condenser fin coil): -

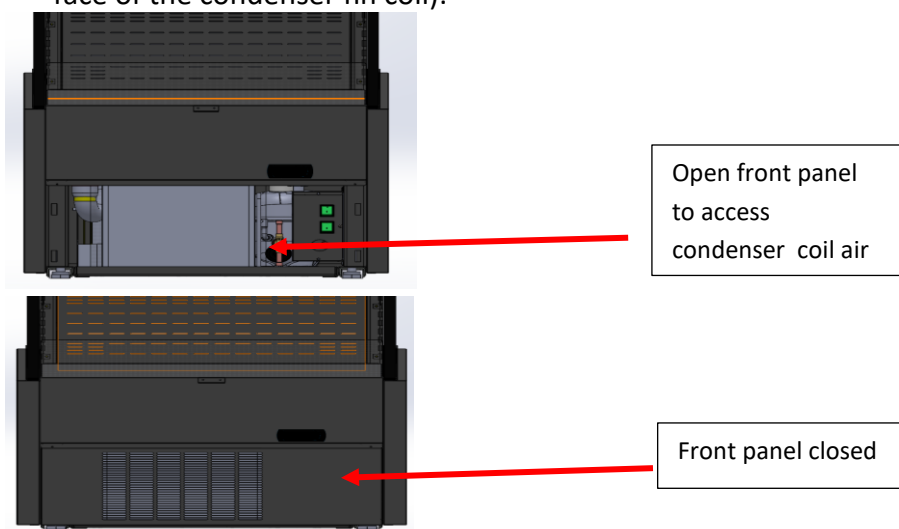

Inspection

1. Check that all case panels and trims are secure and undamaged
2. Check for rust and paint damage
3. Ensure all cable connections, including screw terminals, earth leads, and straps are secure.
4. Ensure insulation to all electrical components including:- fans, heaters, controls, earth terminals and lights are sound.
5. Carry out electrical safety tests, including earth continuity and insulation resistance as appropriate.
6. Check the defrost water dissipater tray sponge wicking pads are clean and in good condition (replace if signs of wear/deterioration).
7. Ensure that there are no refrigerant leaks.
8. Check that all fans, lights, and controls are working.

Deep Clean



CAUTION: -

The case does not have a floor drain. Do not bucket more than 1 litres into the case during cleaning.

1. Remove stock from the case and store below +5°C.
2. Turn off power to the case.
3. Remove shelves and clean with a sponge, warm water and mild detergent, then rinse and wipe dry.
4. Remove and clean the base trays with a sponge, warm water and mild detergent, then rinse and wipe dry.
5. Remove any foreign material from the base of the case.
6. Clean the evaporator coil and check it for damage.
7. Remove honeycomb vents and wash in warm soapy water (All water must be removed from the honeycomb cells before placing it back in the case). A vacuum cleaner may also be used to clean the honeycomb.
8. Wipe LED lamps with a dry cloth.
9. Carefully flush the waste drain and drain trap with a bucket of water and allow the base to drain. NOTE: - maximum 1 litres water and keep observation of the water tray level in the lower section of the cabinet. This cabinet is not connected to a floor drain.
10. Clean the waste drain/trap with a soft brush and warm water.
11. Wipe down the inside of the case, including the perforated rear air delivery panels and air return grill with a clean soft cloth, warm water and mild detergent.
12. Clean glass or mirrored surfaces with a clean soft cloth and mild glass cleaner.
13. Clean the condenser coil with a soft brush or a vacuum cleaner. The dust and fluff obstructs good air circulation and reduces cabinet performance and increases energy consumption. To reach the condenser coil, remove the protection grill, clean it very carefully (avoid touching other components) and put the grill back in its place.
14. Clean the water dissipater tray - To reach the dissipater tray, remove rear lower panel, clean (avoid touching other components) and replace in backward order ensuring the drain outlet is correctly positioned over the water dissipater tray. Check the defrost water dissipater tray sponge wicking pads are clean and in good condition (replace if signs of wear/deterioration).
15. Clean the outside of the case with warm water and a disinfectant solution.
 - a. General clean with a sponge, warm water and mild detergent, then rinse and wipe dry.
 - b. Clean any rust, salt or deposits on and around the water dissipater tray assembly.

16. Clean the outside of the case with warm water and a disinfectant solution.
17. Clean bumpers and plastic parts with a soft cloth and mild detergent, then wipe dry with a clean cloth.
18. Replace base trays and shelves and turn on case power.
19. Allow the case to attain correct working temperature (approx. 30 minutes) and restock the shelves.

NOTE: After cleaning, make sure to clean the area around the case to prevent slips and falls

Yearly

It is recommended that the water dissipater tray sponge wicking pads are replaced or at least thoroughly checked and cleaned.

Servicing

No servicing of Hussmann cases, including the replacement of LED lamps, is to be undertaken by store staff. Please contact your service provider for all maintenance queries.

Trouble shooting

issue	possible reason	remedial action
Product temperature is higher than requirement	Store condition is warmer or more humid than climate class 3 (+25°CDB/60%RH).	Check store air conditioning is operating correctly.
	Refrigeration plant is not running or operating at inappropriate settings or conditions.	Check that compressor unit is running. If unit is running and other possible reasons are eliminated, then call refrigeration service technician to check plant operation.
	Insufficient or no air flow appears at the cabinet honeycomb air curtain.	Check if case fans are turned on or operating correctly. If any doubt of fan operation contact technician.
		Check if coil is iced-up. If iced-up then check defrost settings are as per the manufacturers guideline or set to suit the store operating condition. A colder store may require longer defrost duration. A

		humid store may need more frequent defrost.
	Case shelf arrangement has been deviated significantly from original specified setup.	Re-align the shelf arrangement as per the original specification.
	Air Return is blocked by merchandise or detritus.	Remove merchandise / clean detritus so air grille is free on any encumbrances.
	None of above.	Contact refrigeration service technician.
Products are freezing up.	Store condition is too cold compared to design climate class 3.	Check store air conditioning operation. If store condition cannot be lifted, then adjust cabinet set-points and defrost strategy to suit.
Cabinet exterior is sweating.	Store humidity is high.	Check store air conditioning operation.
	Insufficient ventilation.	Check case ventilation under and at rear of the case. A fan kit may be needed due to local/micro-climate conditions.
	Case set too cold.	Check cabinet controller set-points are as per the manufacturers guideline or set to suit the store operating condition.
LED Lights are not working.	No power supply.	Check supply is "on" and light switch is working.
	Light cable connection loose.	Have your refrigeration service provider fault find and rectify as needed.

	LED Lamp or power driver failed	Have electrician fault find and repair as needed.
Water spill on the floor.	The water dissipater tray is full or leaking.	Contact service provider.
	Store humidity is too high. Water dissipator system operating above maximum conditions.	Contact service provider.
The compressor doesn't start after 2 minutes.	The power supply cable is disconnected.	Reconnect plug.
	The circuit breaker has tripped.	Contact service provider.
	The unit is damaged.	Contact service provider
Increased cabinet noise	The condenser coil is dirty	Contact service provider
	The evaporator is blocked with ice	
	The compressor is damaged	
The compressor never stops	The condenser coil is dirty.	Contact service provider
	The cabinet has a leak and is low on refrigerant.	
	The digital control unit is not regulating or is damaged.	
	The evaporator is blocked with ice.	

Risk analysis

Hazard	Control Measures
Electrical - Replacement of electrical components	Request a service call. Electrically isolate cases before works
Ergonomic - Moving / positioning / adjusting cabinet(s)	Staff must be trained in the correct procedures for setting up cabinet(s) and ergonomic practices. PPE must be worn
Falling - Checking wiring during servicing	Use of barriers & fall arrest systems as appropriate & in accordance with State & Territory Legislation. Safe working at heights
Entanglement - Contact with fans when cleaning	Electrically isolate cases before work is carried out. Staff training,
Cuts and stabbing - Potential for cuts from cleaning evaporator or condenser coils	Electrically isolate cases. Call service provider. PPE must be worn.
Electrical - Potential for electric shock when cleaning electrical fittings and components	Electrically isolate cases before work is carried out. Staff training, RCD. Keep electrical connections dry at all times.
Falling - Climbing on shelves	Staff must be trained in OH&S procedures. MUST not climb on shelves or cabinet
Crushing - Hands or fingers may become pinched or crushed during the positioning of base trays, shelves & stock	Staff must be trained in the correct procedures for setting up cabinets and ergonomic practices
Slipping - Drain may leak or become blocked causing water spillage	Visual Inspection and regular maintenance. Request service call when necessary.
Cuts and stabbing - Potential for cuts caused by damaged or missing parts	Visual Inspection and regular maintenance. Request service call when necessary. PPE must be worn when handling broken or damaged parts.
Ergonomic - Stretching during the cleaning of the cabinet and positioning of stock and shelves leading to strains and sprains	Staff must be trained in the correct procedures for cleaning cases & ergonomic practices. Cleaning tools which reduce the need for stretching should be used.

Slipping - Surfaces may become slippery due to spillage from the case during operation or cleaning	Visual Inspection. Appropriate remedial action.
Cuts and stabbing - Cleaning cold glass surfaces with hot water	Do not use hot water to clean any parts of the cabinet. Staff must be trained in the correct procedures for cleaning cases and ergonomic practices
Crushing - fingers, hands or body between product trays	Operators to always lift product trays using finger pulls provided, ensuring the area is clear of other persons.
Electrical - electrical connections in cases	Electrically isolate cases before work begins. An electrical work must be carried out by an appropriately trained service provider.

To obtain warranty information or other support, contact your nearest Hussmann representative.

Please include the following:

Customer and site location.

Cabinet model & serial number.

Reason for warranty.

Start-up Check List

Step	Start-up Activity	Check
1	Read, and place this install/operation manual in a safe place for future reference.	
2	Examine unit. Confirm there is NO damage or concealed damage.	
3	Level the unit, side to side and front to rear. Check for stability and ensure roller wheels are not in contact with the floor once in final position.	
4	Remove all shipping braces etc.	
5	Unit connected to a dedicated electrical circuit, without the use of an extension cord.	
6	The proper electrical supply has been used for the equipment.	
7	Verify all electrical wiring is secured and clear of any sharp edges or hot lines.	

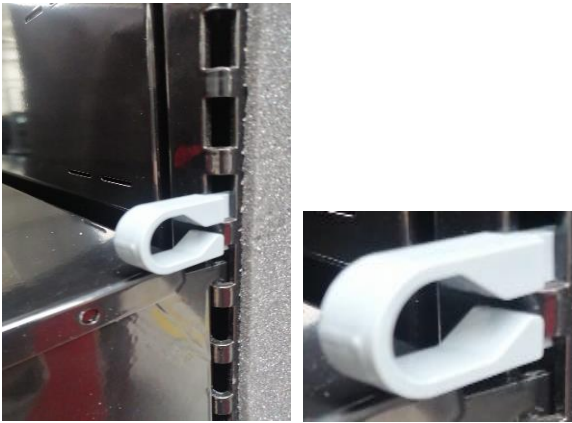
Step	Start-up Activity	Check
8	<p>Verify discharge air honeycomb is correctly positioned, if mis-placed this can be easily corrected using a pair of long-nose pliers or narrow width screwdriver to gently pull the honeycomb down into its retainer position.</p> 	
9	<p>The shelves should be in the correct positions, but if not, these can be re-positioned in the normal manner after the transport retainer clip located above each shelf and on each side of shelf is pulled by hand. See photos below: -</p> 	
10	Verify all required clearances on the front, sides, and back of unit.	
11	Verify there are no air disturbances external to the unit. Heat and air registers, fans, and doors etc.	

Advise owner/operator that merchandiser must operate for minimum 4 hours at temperature prior to loading with product.

End-of-Life decommissioning of the Cabinet

It is encouraged that the cabinet be refurbished if practical.

Plan and risk assess the decommissioning process to include the following:

Isolate the case electrically.

Removal of the case is to be in the reverse order of installation listed previously.

Case disposal is to be carried out by the following: Metal component removed and recycled, remaining by commercial waste management.

If disposal is necessary, please be aware that the foam-insulated panels incorporate cyclo-pentane as the blowing agent and will require the cabinet to be disposed of in accordance with local authority guidelines.



NOTE: - Please recycle as many parts as possible

Appendix A/. Wiring Diagram

Electric Panel Wiring Diagram

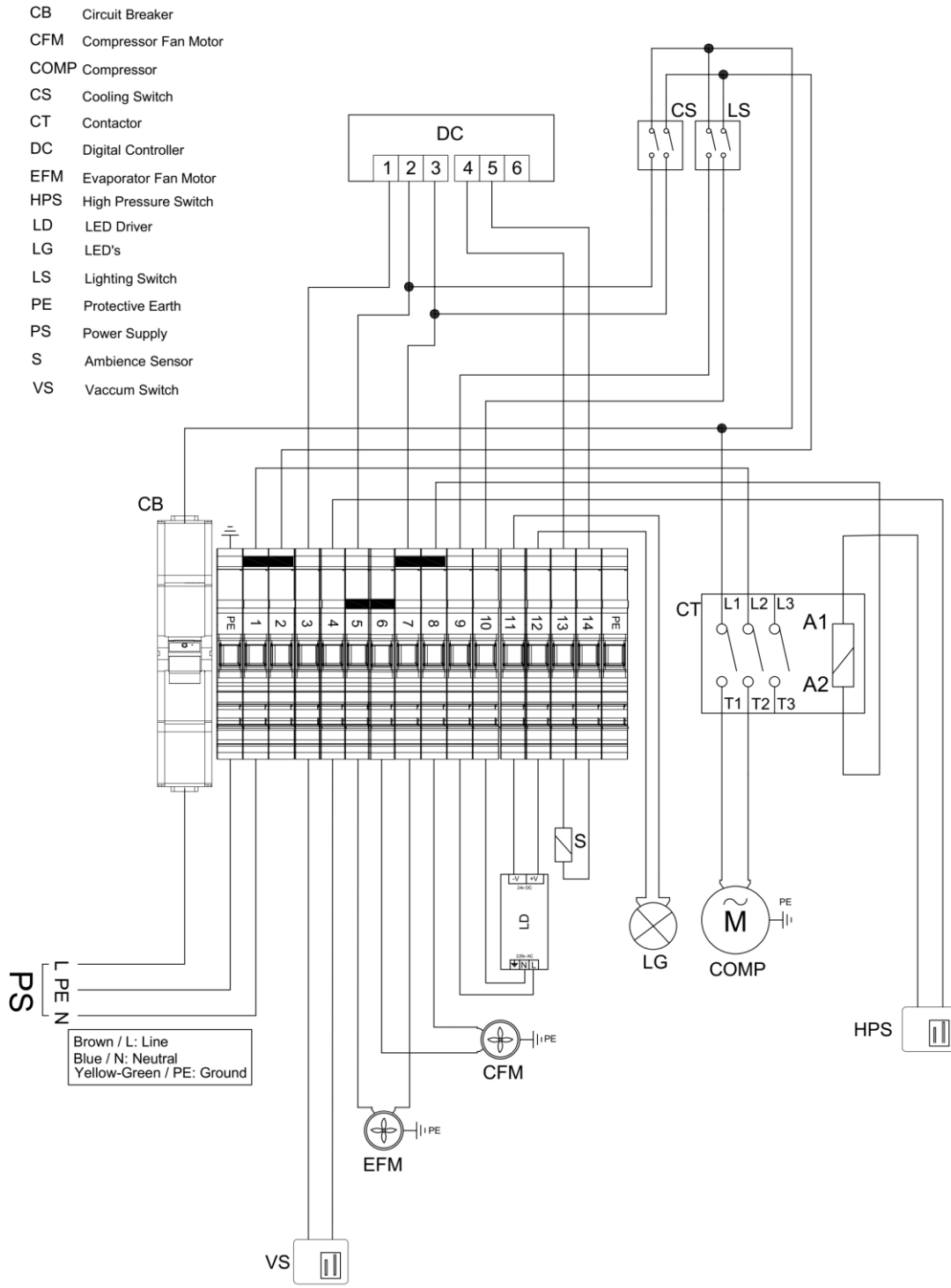

Model: SGN141-S
 Date/Rev: 07.03.2021/01
 Drawing: M. AKIN

Attention: The copyright and all other rights relating to this publication belong to Çağlayan Refrigeration. All rights reserved. Neither may be reproduced or transmitted in any form means without the prior written license from the owner. Çağlayan Refrigeration reserves the right to change any technical details and accessories without previous notice.