



INSTRUCTIONS MANUAL

MODELS

HL300, HL300C,
HL400, & HL400C

ML-134348
ML-134351
ML-134358
ML-134359
ML-134390
ML-134454
ML-134461
ML-141053



*701 S. RIDGE AVENUE
TROY, OHIO 45374-0001*

937 332-3000

www.hobartcorp.com

TABLE OF CONTENTS

GENERAL	3
INSTALLATION	4
Unpacking	4
Location	4
Electrical Connections	5
OPERATION	6
Controls	7
Bowl Placement	8
Agitator	8
Bowl Lift	8
Prepare for Mixing	9
Timer Operation	9
Operating Notes	10
Unloading	11
Wire Cage	11
CLEANING	13
MAINTENANCE	14
Lubrication	14
Adjustments	15
TROUBLESHOOTING	16
Service	16

INSTALLATION, OPERATION AND CARE OF LEGACY® 30-QUART AND 40-QUART MIXERS

SAVE THESE INSTRUCTIONS

GENERAL

The Legacy® 30 and 40-quart mixer series are heavy-duty mixers which feature a 3/4-horsepower motor system for the HL300 and a 1.5-horsepower motor system for the HL400. Both mixers feature a SmartTimer™, a manual bowl lift, a #12 attachment hub as standard equipment and are equipped with Stir, plus three mixing speeds.

A variety of attachments, agitators and accessories are available. These are described in a separate *Use and Applications Handbook*, which is furnished on the Legacy® Mixer Operator Training CD provided with each mixer.

A 20-quart bowl and agitators are available for HL300. A 20 and 30-quart bowl and agitators are also available for HL400.

INSTALLATION

UNPACKING

Immediately after unpacking the mixer, check for possible shipping damage. If this machine is found to be damaged after unpacking, save the packaging material and contact the carrier within 15 days of delivery.

LOCATION

Prior to installation, test the electrical service to assure that it agrees with the specifications on the machine data plate.

Place the mixer in its operating location. There should be adequate space around the mixer for the user to operate the controls and to install and remove bowls. The area above and to the rear of the mixer should allow the top and back covers to be removed for routine maintenance and servicing.

Once in position, the mixer must be leveled:

- Remove the two top cover screws and the top cover.
- Place a level on the top rim (Fig. 1). Slide shims under the base contact surface of the mixer as required to level it front-to-back and side-to-side.
- Do not replace the top cover until installation is completed.



Fig. 1

Lubrication

This mixer is shipped with grease in the transmission. Refer to Lubrication on page 14 for applicable lubrication procedures.

ELECTRICAL CONNECTIONS

⚠ WARNING The electrical cord on the HL300 (single-phase only) is equipped with a three-pronged grounding plug which must be connected to a properly grounded receptacle. If the receptacle is not the proper grounding type, contact an electrician. Do not remove the grounding prong from the plug.

⚠ WARNING Electrical and grounding connections must comply with the applicable portion of the National Electrical Code and/or other Local Electrical Codes.

⚠ WARNING Disconnect the electrical power to the machine and follow lockout / tagout procedures.

For the three-phase HL300 and all HL400 mixers, a hole for the 3/4"-trade-size conduit is located at the top of the pedestal. Make electrical connections per the wiring diagram located on the inside of the top cover.

Single-Phase Mixer, HL400:

- Connect field supply lead wires to L1 and L2.
- Connect ground wire to ground lug on the mixer.

Three-Phase Mixer, HL300 & HL400:

- Connect field supply lead wires to L1, L2 and L3.
- Connect ground wire to ground lug on the mixer.

Check Initial Operation

1. Apply power to the mixer.
2. Turn the SPEED dial pointer to STIR.
3. Install the bowl and lock into mix position, with the Bowl Support all the way up and bowl guard closed. Momentarily run the machine by pushing the START and then STOP buttons.

OPERATION

⚠ WARNING Moving agitator in bowl. Keep hands, clothing and utensils out while in operation. Do not use without interlocked guard.

The Legacy mixer is equipped with SmartTimer™ controls and a manual bowl lift. Other operating parts (Fig. 2) and their functions are described throughout the Operation section.

The bowl guard wire cage must be in closed position or the mixer will not operate.

The bowl must stay in mix position on bowl support and the bowl support must be raised (mix position) or the mixer will not operate.

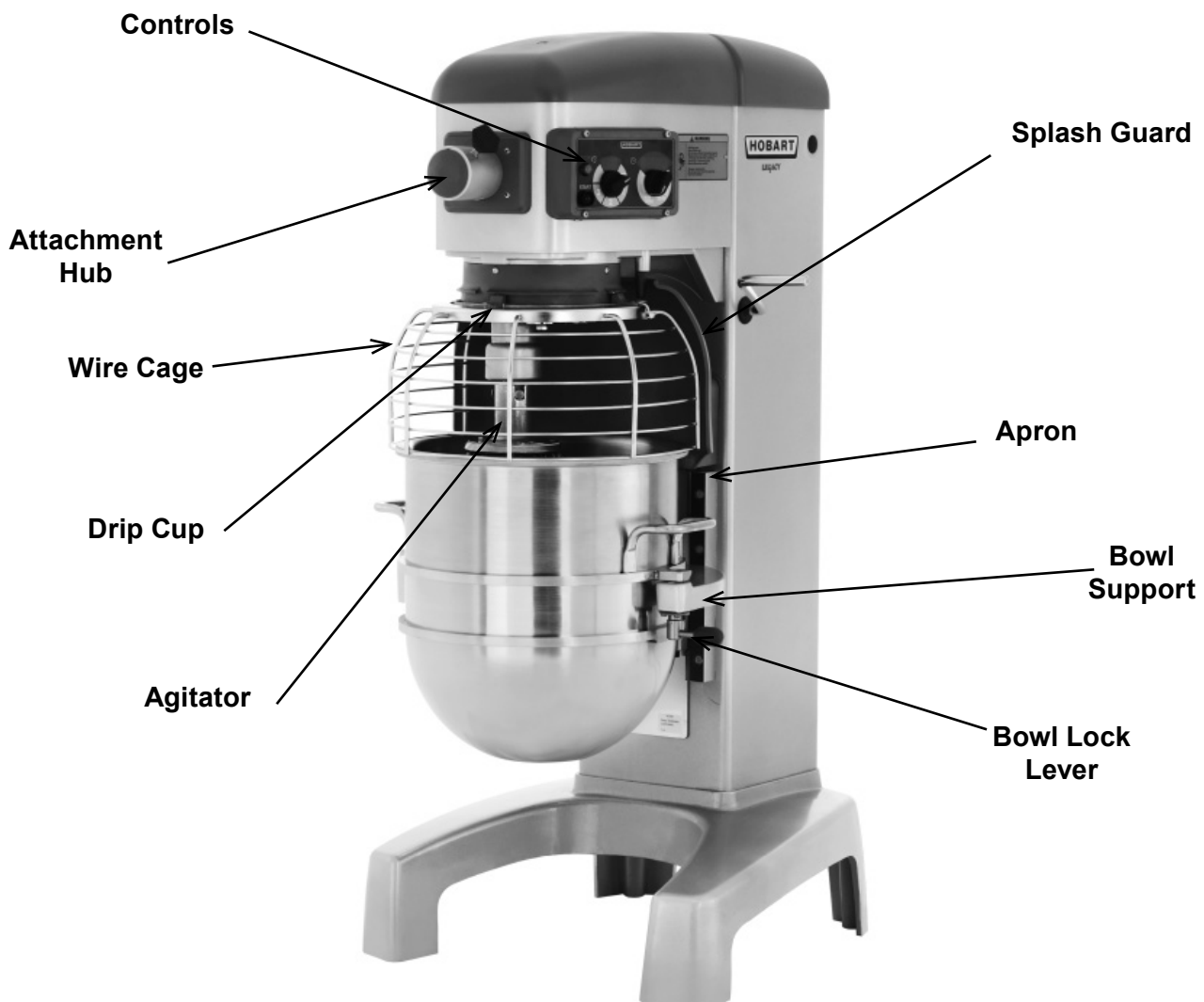
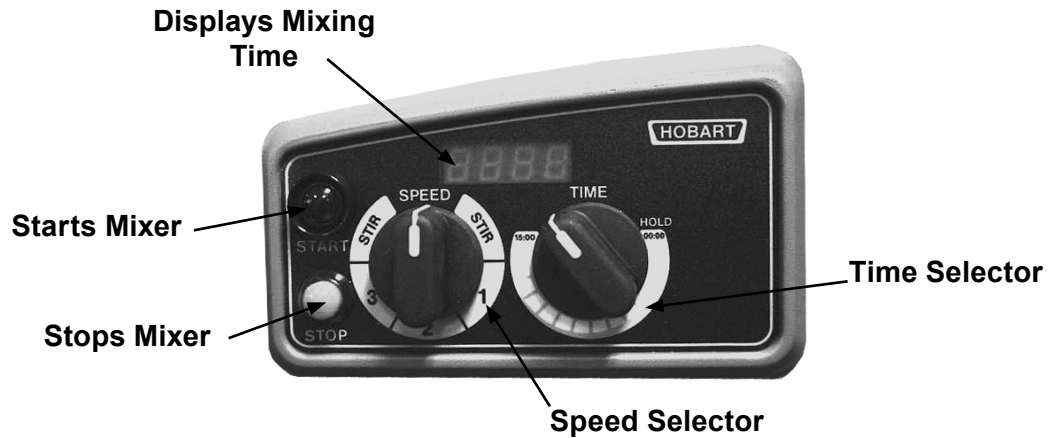

Fig. 2

CONTROLS

Model HL300 (With Three Mix Speeds Plus Stir Speed)



Model HL400 (With Three Mix Speeds Plus Stir Speed)

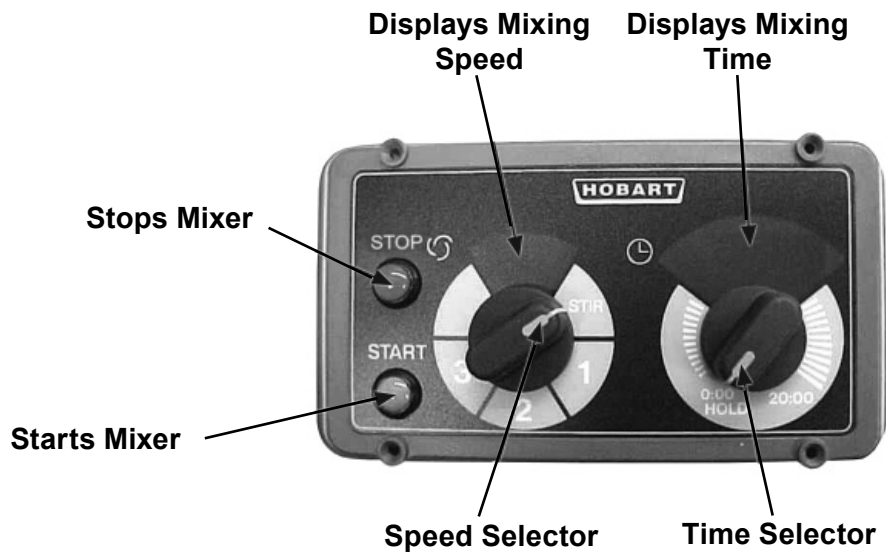

Model HL300/HL400 Mixer Speeds

- STIR (Slow) STIR speed is for incorporating ingredients at the start of each mixing process.
- SPEED 1 (Low) This speed is for heavy mixtures such as pizza dough, heavy batters and potatoes
- SPEED 2 (Medium) This speed is for mixing cake batters, mashing potatoes and developing bread dough.
- SPEED 3 (High) This speed is for incorporating air into light batches, as well as finishing whipped items.
- TIMER Count up (Hold), 15 minute HL300 count down and 20 minute HL400 count down.

BOWL PLACEMENT

The bowl must be installed before the agitator is installed.

To install the bowl, fully lower the bowl support. Position bowl so the alignment pin on the left side of the bowl support fits in the hole in the bowl tab. Place the slotted tab on the bowl into the lower part of the pin. Lower the bowl onto the bowl support and swing the bowl into the locked position.

AGITATOR

To install an agitator, the bowl must be on the bowl support and fully lowered.

To Install

1. Open the wire cage.
2. Place the agitator inside the bowl and align the horizontal slot on the agitator with the agitator shaft pin.
3. Slide the agitator up the agitator shaft until it stops and latches. An audible click should be heard when the agitator locks into position.

To Remove

1. Open the bowl guard wire cage.
2. Lower the bowl.
3. Hold the agitator and pull the plunger of the agitator out (Fig. 3). Slide agitator down off the agitator shaft.

BOWL LIFT

NOTICE Before lowering the bowl onto a bowl truck, always unlock bowl and swing bowl out slightly.

To raise the bowl, the bowl must be in the locked position. Push down the lift handle until it is locked. To lower the bowl, lift the lift handle slowly.



Fig. 3



PREPARE FOR MIXING

1. Place the mixing bowl on the bowl support.
2. Pour ingredients into the bowl.
3. Swing the bowl back to the locked position.
4. Place the agitator inside the bowl, then attach it to the agitator shaft.
5. Return the wire cage to front-center position.
6. Push down the lift handle until the lift handle is locked and the bowl reaches the mix position.
7. The mixer is now ready for mixing (Fig. 4).
(See Timer Operation.)



Fig. 4

TIMER OPERATION

Using the Count-Up Mode (Continuous Mixing)

1. Turn the SPEED dial to select a mix speed (the SPEED setting can be changed at any time during the mixing operation).

NOTICE STIR is to be used for incorporating ingredients. Do not use to develop dough products.

2. Set the timer on hold by turning the TIME selector counterclockwise until "Hold" appears in the TIME window.
3. Press the START button to begin mixing. The timer starts counting forward from 00:00.
Note: If the wire cage is opened at any time, the mixing operation will stop. To resume the mixing operation, close the wire cage and press the START button.
4. Use the STOP button to stop the mixer; the mixing time is displayed in the TIME window.
5. Press the START button to resume mixing if needed.

Note: When the timer reaches 15:00 minutes for the HL300 and 20:00 minutes for the HL400, it will rollover to 00:01 and continue counting until the STOP button is pressed.

Using the Count-Down Mode (Timed Mixing)

1. Turn the SPEED dial to select a mix speed.
 - a. If the count-up mode was used for the previous batch, the desired time needs to be entered.
 - b. If the count-down mode was used for the previous batch, the previous time will be displayed. If a different time is needed, turn the TIME selector to the desired time.
2. Press the START button to begin mixing; the timer starts counting down from the set time.
 - a. To stop the mixer at any time, press the STOP button. To resume mixing, press the START button. For example: The mixer is started at SPEED 1 for 20 seconds and is stopped after 10 seconds. Pressing the START button will resume the mixing operation.
 - b. If the mixer is stopped and a new time setting is entered, pressing the START button saves the new time setting on the current speed selection. For example: The mixer is started at SPEED 1 for 20 seconds and is stopped after 10 seconds. A new time is entered by turning the TIME selector. The new time will replace the initial 20 seconds for SPEED 1 after the START button is pressed.
 - c. If the time is changed while mixing, the mixer will operate until the new time expires. The adjustment to the time will not be stored.
 - d. If speed is changed while mixing, the time will change to the previous time for the selected speed and count down.

NOTE: If the wire cage is opened at any time, the mixing operation will stop. To resume the mixing operation, close the wire cage and press the START button.

3. When the timer reaches 00:00, the mixer stops; a beeper sounds. The count-down timer displays the last-entered time.

OPERATING NOTES

- STIR is to be used for incorporating ingredients. Do not use it to develop dough products.
- If the mixer is stopped during a mixing operation, the timer also stops. The timer starts again (with the time remaining) when the START button is pressed.
- For the HL400, the SPEED window will display the SPEED dial's current speed selection.
- Turn the TIME selector clockwise to take the mixer out of the hold mode.

UNLOADING

1. Lift the lift handle slowly to lower the bowl support. Unlock the bowl and swing-out slightly.
2. Open the wire cage assembly.
3. Remove the agitator from the agitator shaft.
4. Remove the bowl from the bowl support.

WIRE CAGE (Fig. 5)

The bowl guard wire cage can be rotated out of the way to add ingredients or to access the bowl and agitator.

Note how the plastic carriers allow the wire cage to ride around the circumference of the planetary drip cup.

- Open the bowl guard wire cage: rotate it to your left.
- Close the bowl guard wire cage: rotate it to your right until it stops, closed position.

NOTE: The bowl guard wire cage must be returned to the closed position for the mixer to operate.



Fig. 5



Remove and Clean Bowl Guard Wire Cage (Fig. 6)

1. Rotate wire cage to your left until the three carriers align with the carrier escape slots in the circular ridge of the planetary drip cup.
2. Lift the wire cage straight up so the carriers escape from the slots on the drip cup. The bowl guard wire cage can now be removed by pulling toward you.



Fig. 6

3. Wash the bowl guard wire cage in a sink, rinse with clear water, and dry with a clean cloth.
4. The splash guard can be wiped off and/or washed with a cloth or sponge using warm, soapy water. Rinse with clear water and dry with a clean cloth.

Reinstall Bowl Guard Wire Cage

1. Position the ring of the bowl guard wire cage so the carriers are positioned above the slots in the planetary drip cup.
2. Lower the bowl guard wire cage so the carriers pass through the slots.
3. Rotate the bowl guard wire cage to your right until it contacts the stop, closed position.

CLEANING

⚠ WARNING Disconnect the electrical power to the machine and follow lockout / tagout procedures.

New mixer bowls and accessories (beaters, whips and dough arms) should be thoroughly washed with hot water and a mild soap solution, rinsed with either a mild soda or vinegar solution and thoroughly rinsed with clear water before being used. This cleaning procedure should also be followed for bowls and agitators before whipping egg whites or whole eggs.

The mixer should be thoroughly cleaned daily. DO NOT use a hose to clean the mixer; it should be washed with a clean, damp cloth. The base allows ample room for cleaning under the mixer.

The drip cup (Fig. 2, page 6) should be removed (which is secured with 3 screws) periodically and wiped clean.

For cleaning the Wire Cage refer to page 12.

MAINTENANCE

⚠ WARNING Disconnect the electrical power to the machine and follow lockout / tagout procedures.

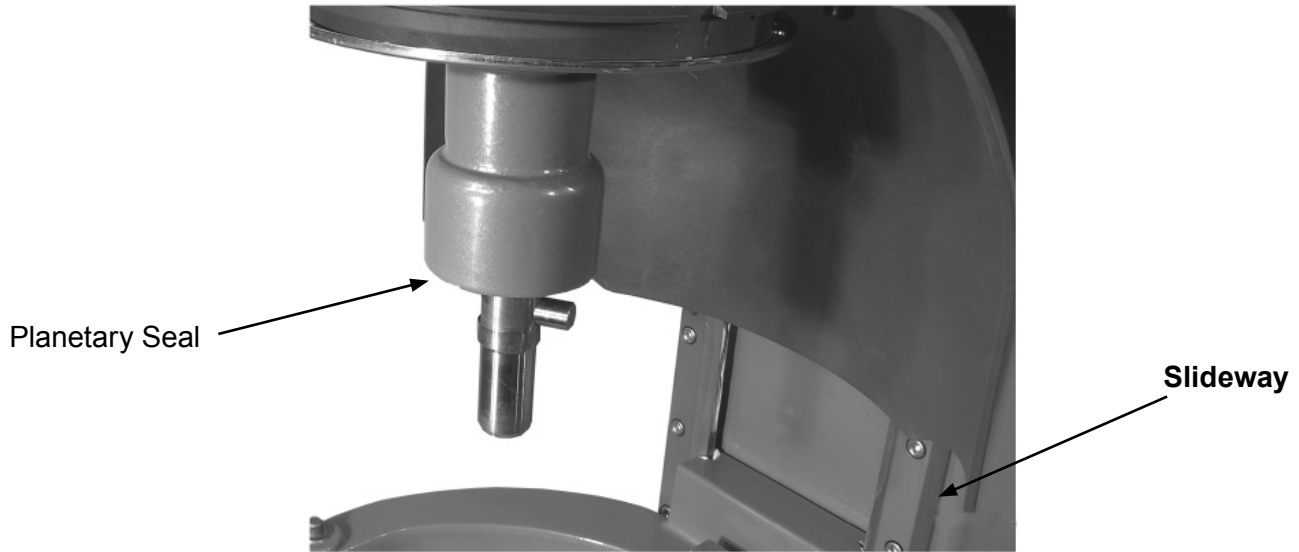

Fig. 7

LUBRICATION

Slideway

The slideways (Fig. 7) should be lubricated approximately twice a year. To reach these areas, fully lower the bowl support. Wipe a thin coat of Lubriplate 630AA on the bowl pad area of the bowl supports and on each slideway.

Planetary Seal

Occasionally, the planetary seal (Fig. 7) may become dry and begin to squeak. To correct this, work a little lubrication (mineral oil) under the lip of the seal.

ADJUSTMENTS

Agitator Clearance

The agitator clearance should be checked periodically. The agitator must not touch the bowl, and the maximum clearance between the bottom of the bowl and the B flat beater is 1/8" (3 mm); the maximum clearance between the bottom of the bowl and the ED dough arm is 5/16" (8 mm).

Install a bowl and agitator (e.g., beater). If the bowl and beater come into contact before the bowl support reaches its stop, adjust the stop screw. Refer to Adjust the Bowl/Agitator Clearance, Figure 8.

Measure Clearance

Pour enough flour in the bowl to cover the bottom of the bowl where the beater travels. With the bowl fully raised (beater should not touch the bottom of the bowl), briefly run the mixer at the lowest speed.

Turn off the mixer, disconnect the electrical power supply, and measure the depth of flour where the beater has traced a path. This measurement should be taken at several points around the bowl to assure accuracy.

Adjust the Bowl/Agitator Clearance

- Turn the stop screws counterclockwise to decrease the clearance or clockwise to increase the clearance. (Fig. 8)
- Reconnect the electrical power supply.
- Carefully operate the bowl lift several times to check the adjustment.



Fig. 8

TROUBLESHOOTING

Symptoms	Possible Causes
Mixer will not start	Flashing Time display - See Below Branch circuit protector is in open position - check fuse or disconnect switch. Mixer is overloaded. Wire cage is not in the closed position. Bowl is not in closed (mix) position or bowl is not in up position.
Agitator touches bowl	Bowl is not in closed (mix) position. Improper agitator clearance - see Maintenance for adjustment procedure. Agitator is not installed properly.
Planetary seal squeaks	Seal requires occasional lubrication - see Maintenance
Timer displays flashing alarm code (Ex. "OL1" - Motor overload)	If the error code is flashing – unplug machine until display is blank then plug back in. If symptoms still exist, contact your local Hobart Service office.

SERVICE

If service is needed on this equipment, contact your local Hobart Service office @ 1-888-4HOBART.