



Manufactured By  
ROBAND AUSTRALIA PTY LTD



# OPERATING INSTRUCTIONS

## DONUT FRYERS

Models: **FD10 Version 4**

**Includes**

International models: **...-G**

### Special Features:

- Thermal Safety Cut Out
- Stainless Steel Donut Lifter
- Ultra-Durable Stainless Steel Elements
- Advanced Control Safety System
- Easy Clean Drain Tray



These instructions cover the models of ROBAND® Donut Fryers only. Although there are slight variances between models, the installation, operation, care and maintenance procedure is the same for all.

Roband® Australia is a wholly Australian owned company and has been manufacturing quality commercial catering equipment for the food service industry for more than 50 years. Roband products are engineered and manufactured to the highest standards to provide functionality, reliability and durability, and our quality products are exported world-wide.

Included in the comprehensive Roband® range are Toasters, Fryers, Milkshake Mixers, Rotisseries, Food Display Cabinets and much more.

Roband® Australia also acts as the Australian agents for Vitamix® Blenders, Noaw® Meat Slicers, Förje® Cookware, Robalec™ Soup/Rice Warmers, Robatherm Urns, Austheat® Fryers, Dipo Induction & Autofry Machines. Roband also has its own line of commercial cookware and cutlery under the Robinox® brand name.

For a complete set of brochures please contact your nearest authorised dealer or contact Roband directly at our head office.

<b>Roband Head Office</b> Sydney, Australia			
Roband Australia Pty Ltd 1 Inman Road Dee Why NSW 2099 AUSTRALIA		Tel: +61 2 9971 1788 Fax: +61 2 9971 1336 Email: <a href="mailto:sales@roband.com.au">sales@roband.com.au</a> Web: <a href="http://www.roband.com.au">www.roband.com.au</a>	
<b>International Agents</b> For additional agents please email Head Office			
<b>Belgium</b>	Linum Europe Ph: +32 (0)56 35 92 96	<b>Noumea:</b>	Comptoir Materiel Professionnel Ph: +687 28 50 43
<b>Fiji:</b>	Hotel Equipment Ltd Ph: +679 672 0666	<b>Papua New Guinea:</b>	Brian Bell & Company Pty Ltd Ph: +675 325 5411
<b>Germany</b>	Lölsberg Ph: +49 9305989780	<b>Singapore:</b>	Allied Foodservice Equipment Ph: +65 62525880
<b>GREECE</b>	K&N Engineers Ltd Ph: +30 210 520 0440	<b>South Africa</b>	Foodservice Solutions (Pty) Ltd Ph: +31 306 017 442
<b>Hong Kong:</b>	Chung Wah Kitchen Machine Ltd Ph: +852 2334 5411	<b>Thailand:</b>	Seven Five Distributors Co Ltd Ph: +662 866 5858
<b>Italy</b>	NOAW Ph: +39 0331 219723	<b>United Kingdom</b>	Metcalfe Catering Equipment Ph: +44 (0) 1766 830456
<b>Malaysia:</b>	Allied Food Equipment Ph: +603 9133 5833	<b>United Arab Emirates:</b>	Boncafe Middle East LLC +9714 282 8742
<b>Maldives:</b>	Radiant Heat Maldives Pty Ltd Ph: +960 333 4845	<b>United Arab Emirates:</b>	Nisa Trading LLC +9714 396 6132
<b>New Zealand:</b>	Roband New Zealand Ph: +649 274 1354	<b>U.S.A.</b>	Smart Kitchen Solutions Ph: +1 508 244 1365

© Copyright 2015 – Roband® Australia Pty Ltd

All rights reserved. No part of this work may be reproduced or copied in any form or by any means, electronic or mechanical, including photocopying or posting to a website, without the written permission of the publisher. The material contained within this document is intended entirely for instructional purposes.

---

# CONTENTS

INTRODUCTION .....	1
GENERAL PRECAUTIONS .....	1
PACKAGING .....	2
COMPLIANCE .....	2
INSTALLATION .....	3
OPERATION.....	4
GENERAL SAFETY .....	5
GENERAL FIRE SAFETY .....	5
SAFETY FEATURES.....	6
CLEANING, CARE & MAINTENANCE .....	7
TROUBLESHOOTING.....	8
SPECIFICATIONS.....	9
CIRCUIT DIAGRAM.....	10
PARTS LIST .....	11
APPENDIX A .....	12
WARRANTY .....	16

---

## INTRODUCTION

Congratulations on your purchase of this quality ROBAND® product. With proper care and management your new purchase will give you years of trouble free service.

By reading these instructions carefully you can ensure that this machine is used and maintained properly, helping your new investment to perform well for you now, and to continue performing in the many years to come.

## GENERAL PRECAUTIONS

This machine must only be operated by qualified person(s) who are fully versed in the operating and safety instructions described in this manual. Operators should be instructed to familiarise themselves with any and all safety instructions described in this manual prior to commencement of any maintenance or service.

In the case of new personnel, training is to be provided in advance. These machines should not be operated by persons (including children) with reduced physical, sensory or mental capabilities, or lack of experience or knowledge, unless they are being supervised or being instructed concerning the safe use of the appliance by a person responsible for their safety.

 These machines are heating units, and as with any commercial heating unit the surfaces on these Donut Fryers will get hot. Always be careful when near an operating Grill Station, and ensure that any risk to unwary customers or staff is minimised with additional signage if necessary. Due to the obvious heat hazard Roband recommends that these units be kept out of reach of children.

These Donut Fryers are for use with oil. The machines are not designed for use with water for such task as cooking pasta, and any such misuse will void the warranty.

 The machine should be disconnected from all power and allowed to cool before cleaning. Any damaged plug or cord should be replaced before further use.

### **ROBAND WILL ACCEPT NO LIABILITY IF;**

- ◆ Non-authorized personnel have tampered with the machine.
- ◆ The instructions in this manual have not been followed correctly.
- ◆ Non-original spare parts are used.
- ◆ The machine is not cleaned correctly, with the right product.
- ◆ There is any damage to the unit.

---

## PACKAGING

All care is taken when packing and Roband ensures that every unit is functional and undamaged at the time of packaging.

The Package of these Donut Fryers should include:

- 1) One Fryer
- 2) Two Donut Lifters
- 3) Two Cooking Racks
- 4) This manual
- 5) One control box
- 6) Packaging materials

Any damage to the machine as a result of freight must be reported to the Freight Company and to the agent responsible for the dispatch of said unit within 24 hours of receipt. No claims will be accepted or entertained after this period.



### **RCM:**

Roband® products have been designed and manufactured to comply with any and all specifications set out by the Australian Communications and Media Authority (ACMA) in regards to Electromagnetic Compatibility. As testament to such compliance these units bear the RCM symbol.

For further information contact the Australian Communications Authority, PO Box 13112, Law Courts, Melbourne VIC 8010.

### **CE:**

Roband® products bearing the CE compliance mark have been designed and manufactured to comply with European Standards and Directives.

---

## INSTALLATION

- ⇒ Remove all the packaging materials and tape, as well as any protective plastic from the machine. Clean off any glue residue left over from the protective plastic using methylated spirit.
- ⇒ Place the fryer on a firm, level surface in the required position. The feet can be adjusted for an uneven surface. Take a moment to familiarise yourself with the general arrangement of the fryer before going any further.
- ⇒ National Standards exist outlining the positioning, spacing and ventilation requirements when installing new appliances. These Standards should be consulted and new equipment should be installed accordingly. In any situation where specifications allow a distance of less than 100mm we would still recommend that a well-ventilated air gap of not less than 100mm be maintained. If the machine is near particularly heat-sensitive materials common sense should be employed in determining sufficient distancing.
- ⇒ The element and controls are designed as separate components to the body and pan. These are collectively referred to as the control box. The main switches, thermostats and pilot lights are located on the face of the control box.
- ⇒ The control boxes can be tilted back and rested in the upright position or removed altogether from the fryer body. Once removed, the pan may then be removed by sliding your fingers beneath the handles and lifting them out.

**Caution:** Ensure pan has cooled before attempting to remove it.

- ⇒ Before connecting the fryer to the power supply ensure that **all** the controls are in the “**OFF**” position.
- ⇒ Plug the control box of the fryer into a standard, single phase, 10Amp power point.

### RCD Protection

We recommend the use of an RCD (Residual Current Device) rated at not less than 30mA for circuit protection when using these units. Note that if one RCD is used to protect multiple socket outlets, the RCD shall be appropriately rated so as to allow up to 30mA from these machines alone.

---

## OPERATION

- ⇒ Place the tank in the fryer. Place the control box in position and the element guard over the element in the bottom of the tank.
- ⇒ Fill the tank with the required volume of oil. The specifications at the end of these instructions indicate the correct volume of oil.
- ⇒ Rotate the on/off knob to the on position. The green pilot light will indicate that the machine is on. Rotate the thermostat knob to select the desired cooking temperature. As a guide, between 170° and 180°C should suffice but experience will dictate the best cooking temperature.

**Caution:** If using “solid” type cooking oil, this **must** be melted very slowly by turning the thermostat on to the lowest setting for about 10 to 15 seconds, then off for a similar period. Repeat this process until the level of **liquid** oil reaches the minimum oil level mark. This is to prevent the possibility of the oil igniting.

When the temperature has been set the pilot light will illuminate indicating that heating is taking place. When the oil has reached the set temperature the pilot light will go out. The thermostat will then continue to cycle on and off, maintaining the set temperature.

---

# ⚡ SAFETY ⚡

## GENERAL SAFETY

This machine contains no user-serviceable parts. Roband Australia, one of our agents, or a similarly qualified person(s) should carry out any and all repairs. Any repair person(s) should be instructed to read the Safety warnings within this manual before commencing work on these units.



- ⇒ Steel cutting processes such as those used in the construction of this machine result in sharp edges. Whilst any such edges are removed to the best of our ability it is always wise to take care when contacting any edge. Particular care should be taken when panels are removed (eg during servicing) as this may expose sharp edges.

- ⇒ Do not remove any cover panels that may be on the machine.



- ⇒ This unit can get very hot, ensure everyone is aware that the machine is operating and take care to avoid contact with hot surfaces. Hot surfaces should be left well ventilated with an air gap of at least 100mm, though common sense should be used if the machine is near heat-sensitive materials.

- ⇒ Always ensure the power cable is not in contact with hot parts of the machine when in use. Ensure that any damaged power cord is replaced before further use.

- ⇒ Do not clean this unit with the aid of a Spray Applicator or Water Jet.

- ⇒ These units are not suitable for cleaning in a dishwasher and no parts of these machines (except the grease box) should ever be submerged in water.

- ⇒ Keep out of reach of children or the inept.

## GENERAL FIRE SAFETY

Before using any fryer adequate safety measures should be in place. Such measures should include, but not be limited to, having an appropriate fire extinguisher or fire blanket located nearby in case cooking oil ignites.



---

## SAFETY FEATURES

- ⇒ The FD10 has a thermal overload fitted.
- ⇒ The thermal overload's function is to cut power to the fryer when the oil temperature reaches 238°C, thus preventing the oil reaching flash point temperature.
- ⇒ If the thermal overload trips, it is easily reset by pushing the small red reset button on the rear of the control box after the oil has cooled down by at least 12°C. If the overload continues to trip there may be a fault with the thermostat and you should contact your nearest authorised service agent for further help.

**WARNING:** Always turn both the thermostat and main switch “off” and allow element to cool before lifting the element out of the oil.

**WARNING:** Always turn both the thermostat and main switch “OFF”, and allow element to cool before lifting the element out of the oil.

**WARNING: IMMERSING A HOT ELEMENT IN OIL COULD CAUSE A FIRE.**

**WARNING:** Ensure that oil is changed or filtered regularly. Old or dirty oil has a lower flash point and is more prone to surge boiling.

**WARNING:** Always be careful when cooking frozen or over-wet food products as these items are more prone to surge-boiling and are more likely to result in the “spitting” of hot oil.

**Cooking Tip:** For frozen foods, direct from freezer to fryer, allow 5° higher temperature or slightly longer cooking time. Always shake the cold water and ice from frozen foods before frying. As a general rule for larger food items, cook at a lower temperature and for a longer period of time. For smaller items of food, cook at a higher temperature for a shorter time.

To obtain the optimum results from your fryer we recommend the following guidelines:

- ◆ If solid type cooking oil is used, melt it slowly at the minimum temperature setting.
- ◆ Keep salt away from the cooking oil.
- ◆ Check your oil to food ratio, 6:1 oil to food is recommended.
- ◆ Filter the cooking oil regularly.
- ◆ Top up the cooking oil regularly.
- ◆ Never use copper or brass utensils in the cooking oil.
- ◆ Keep the fryer covered when not in use.

---

## CLEANING, CARE & MAINTENANCE

Attention to regular care and maintenance will ensure long and trouble free operation of your fryer.

- ◆ The Fryer should be cleaned out daily, or more often if necessary.
- ◆ Ensure the power is off and the fryer is cool before attempting to drain the cooking oil or clean any part of the machine.
- ◆ Wipe the fryer down with warm soapy water using a **damp** sponge or cloth. **Do not** immerse the control box in water.
- ◆ Filter the cooking oil daily if the fryer is constantly in use.
- ◆ Empty and wash the drip tray at the bottom the fryer regularly. The tray is removed by simply sliding it out.
- ◆ Always ensure the power cable is not in contact with hot parts of the fryer when in use.

Although every care is taken during manufacture to remove all sharp edges, care should be taken when cleaning to avoid injury.

**Caution:** Some cleaning agents can damage stainless steel or the polycarbonates and plastics used in switches and pilot lights, usually through prolonged use. For this reason we recommend cleaning with soapy water only. Any damage to the unit through the use of harsh or improper cleaning agents is entirely the fault of the user.

**Warning:** No parts of this these units, with the exceptions of the oil pan and drain tray (when detached from the unit), should ever be immersed in water for cleaning or any other purposes.

---

## TROUBLESHOOTING

If the fryer does not function check the following points before calling for service.

- ✓ The control box is plugged in correctly and the power switched on.
- ✓ The power points are not faulty.
- ✓ The temperature has been set correctly and the overloads have not tripped. To reset a tripped temperature overload switch, press the red button behind the control box as indicated in the picture below. Frequent tripping of the overload may indicate a problem.

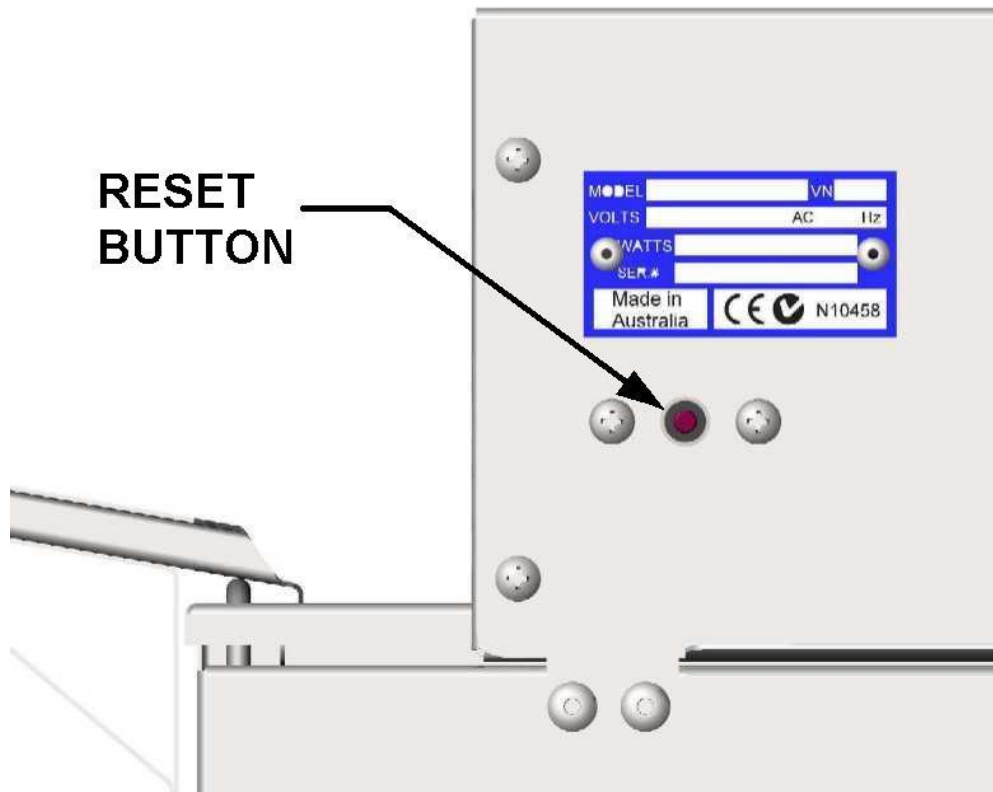

- ✓ The thermostat knobs are not loose or broken, rendering the thermostats inoperable.

# SPECIFICATIONS

Model	FD10 & FD10-UK
Power Source	220-240 Volts AC
Power Frequency	50-60Hz
Power Consumption	2100-2500 Watts
Amps	10
Width mm	740
Height mm	340
Depth mm	489
Weight kg	15

Constant research and development may necessitate specification changes at any time.

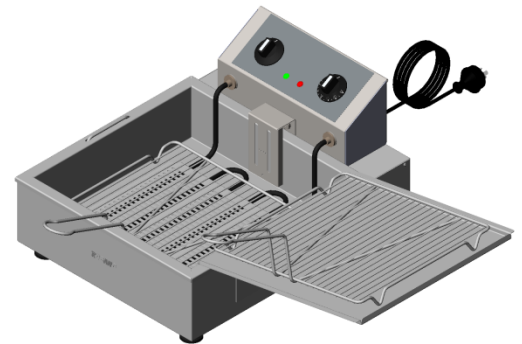
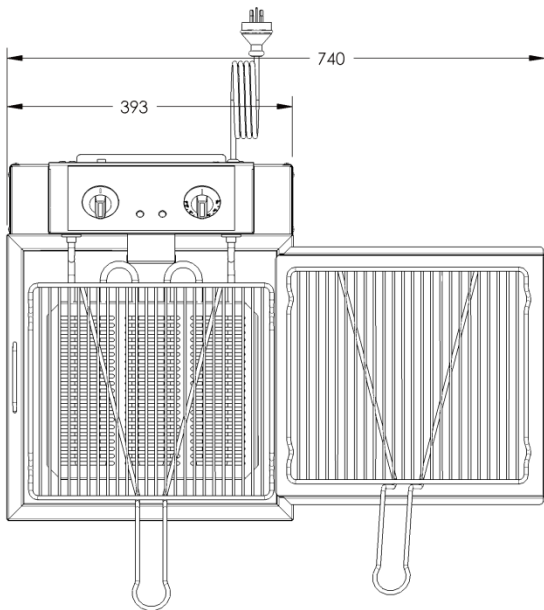
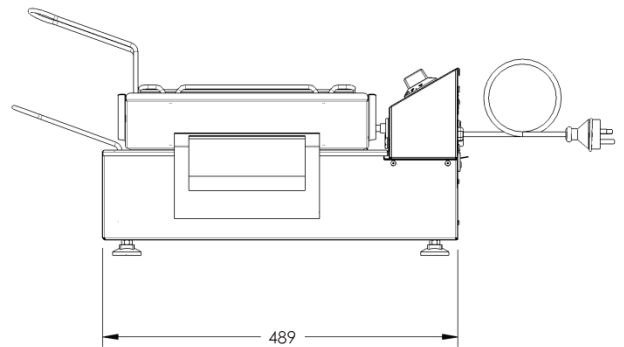
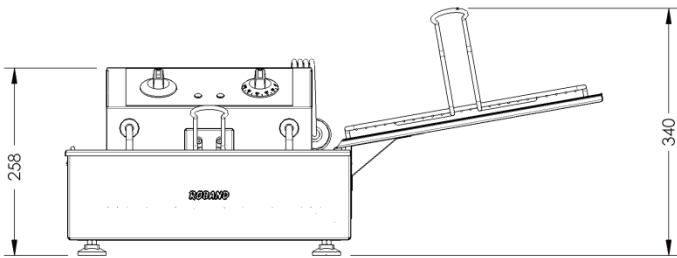

# CIRCUIT DIAGRAM

## MODELS: FD10 – VERSION 3

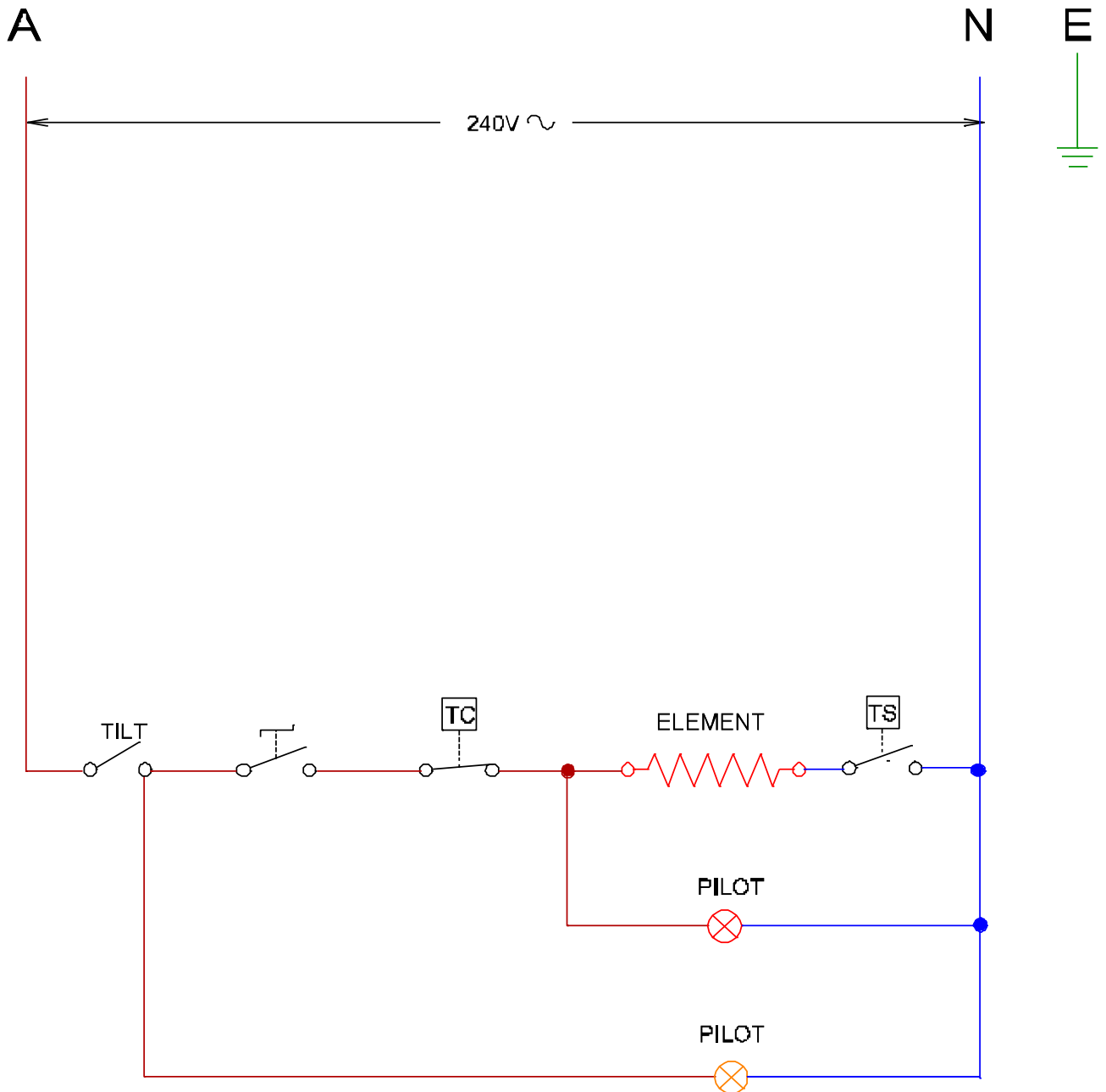

**NOTE: Tilt switch for UK models ONLY.**

TC – Thermal cut-out

TS – Thermostat

**NOTE: This circuit diagram has been provided for reference and to assist qualified service and repair agents only. Under no circumstances should a person not suitably qualified attempt repairs to any electrical equipment**

# PARTS LIST

## F15 PARTS LIST

PART NO	DESCRIPTION	QTY
ES0264	Pilot Light & O-ring 10mm Amber	1
EC0031	Terminal Block - Porcelain/Steatite "1602", L & N marked, 10mm sq.	1
ES0265	Pilot Light & O-ring 10mm Green	1
ES0239	Plug & Cord - 10 Amp Black Thermoset Elastomer - 2BL 1E	1
ES0007	Rotary Switch & Plain Knob - 2 position	1
HC0053	Element - 2300W 240V	1
MC0073	Rack	1
MC0074	Donut Lifter	2
MS0038	Handle Set for Tank	1

PART NO	DESCRIPTION	QTY
PC0060	Cord Clamp - 10A	1
PC0011	Food Set & Nuts	1
PS0021	Knob & S/S Screw	1
SS0226	Drip Tray	1
SS0459	Element Guard	1
TC0026	Thermostat – Limit 240°C -13K	1
TS0005	Thermostat – 205°C & Plain Knob	1
VS0189	Control Box Complete	1
VS0238	Lid (with basket handle cutout) with Knob and Screw	1

---

## APPENDIX A

### RESIDUAL CURRENT DEVICES (RCD'S)

Also known as Earth Leakage Protection systems an RCD is a protective device that automatically disconnects the live conductors of a circuit when an earth leakage current reaches a predetermined value.

Australian and International Standards detail when and where RCD's are to be used in electrical installations, but common practice in many countries is to use a 30mA RCD in general commercial applications. This is typically done because 30mA RCD's are readily available and are used in domestic installations.

For Commercial installations, and for socket-outlets providing power to commercial heating equipment (Toasters, Bains Marie, Grillers), 30mA RCD's are typically unsuitable unless they are protecting only one device. Higher rated RCD's should be considered if protecting multiple socket-outlets, giving appropriate consideration to the type of equipment being protected.

AS/NZS3000 2.5.2 gives the following warnings that should have been taken into consideration when an RCD circuit was installed.

*To avoid unwanted tripping due to leakage currents and transient disturbances, care should be taken to ensure that the sum of the leakage currents of electrical equipment on the load side of an RCD is less than 1/3 of its rated residual current.*

*To avoid excessive leakage current causing unwanted tripping where socket-outlets are protected by one RCD having a rated residual current not greater than 30mA, consideration should be given to the number of socket-outlets protected and the nature of electrical equipment likely to be connected to the socket-outlets.*

Tubular elements (such as those used in this unit) reaching temperatures greater than 110°C are subject to moisture absorption and therefore earth leakage current generation. Should the installation and use of this unit trip an RCD the unit will need to be run on a circuit without an RCD for approximately 30-60 minutes, after which time the elements should have dried out and the machine should function normally. If you are unable to locate a circuit without an RCD please contact your supplier or contact Roband or our Agent for alternative suggestions.

---

# NOTES



---

# NOTES

---

# NOTES

---

## WARRANTY

Every care is taken to ensure that no defective equipment leaves our factory and all goods manufactured by us are guaranteed against defective workmanship and materials for a period of 12 months from the date of purchase. Roband Australia's obligations pursuant to this express warranty being limited to the repair or replacement of the defective goods or materials, at its option and subject to the terms contained within this Warranty statement. Where relevant, glass, Teflon® and lamps are **not** included in this warranty and RCD tripping due to moisture absorption by Tubular Heating Elements is not considered a warranty fault.

Generally, all goods claimed under this warranty must be returned to the factory or an authorized service agent, freight prepaid, for inspection. All parts deemed to be defective will be replaced, however, no claims will be entertained for second hand products, or parts damaged in transport, misused or modified in any way without our approval. For machines that are not considered to be portable (e.g. food bars, rotisseries, large hotplates and some bain maries), on site warranty service will be provided in capital city metropolitan areas only. In all other locations, the customer is responsible for all travelling time/service call costs and payment for this will be required prior to the commencement of the repair. The labour costs to actually repair the fault will be met by the company.

Any repairs or replacement of defective goods or materials pursuant to this warranty, must be authorized by Roband Australia prior to any action being taken. The company reserves the right to reject a claim for warranty if it is not completely satisfied with the circumstances under which it occurred and any other costs incurred for false claims or faults due to incorrect usage etc. are the responsibility of the claimant. Roband Australia Pty Ltd nor any subsidiary company or Agent shall be liable for loss of profit or damage to other equipment and property except where it is in breach of the guarantees provided in accordance with Schedule 2 of the Competition and Consumer Act 2010 (Cth) or the applicable legislation from time to time.

The goods come with guarantees that cannot be excluded under the Australian Consumer Law (ACL). You are entitled to a replacement or refund for a major failure and for compensation for any other reasonably foreseeable loss or damage. You are also entitled to have the goods repaired or replaced if they fail to be of acceptable quality and the failure does not constitute a major failure.

Generally, authorized service agents are located in all areas which have authorized distribution dealers. For the name of your nearest Australian authorised service agent, please contact:

### Roband Australia Pty Ltd

1 Inman Road, Cromer, NSW 2099

Warranty Number: 1800 268 848

Phone: (02) 9971 1788 Fax: (02) 9971 1336

All other countries please contact your selling Agent.

Please complete the following details and keep this card in a safe place.

NAME \_\_\_\_\_

ADDRESS \_\_\_\_\_

MODEL No: \_\_\_\_\_ SERIAL No: \_\_\_\_\_ DATE PURCHASE \_\_\_\_\_

NAME OF DEALER: \_\_\_\_\_

**PLEASE RETAIN THIS SECTION FOR YOUR RECORDS**

**DO NOT POST**

**ROBAND® AUSTRALIA PTY LTD**

OTHER LEADING PRODUCTS AVAILABLE:

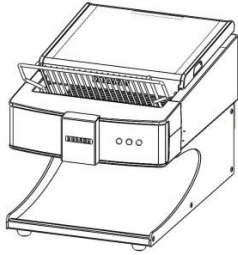

Sycloid Toaster



DRINK MIXERS

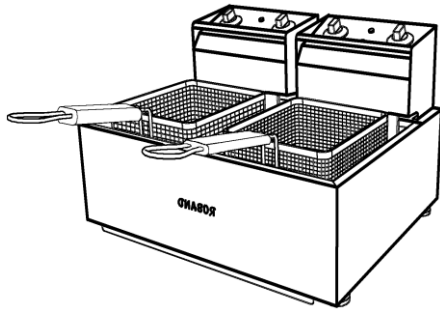

HIGH PERFORMANCE DEEP FRYERS

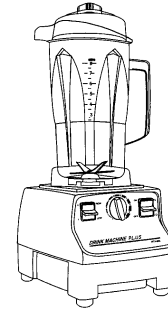

VITAMIX BLENDERS

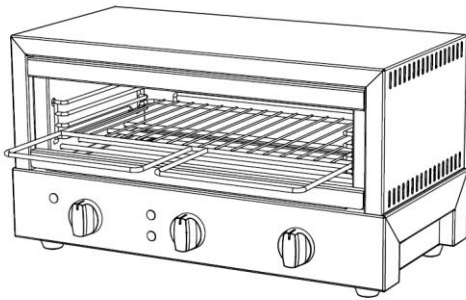

GRILLMAX TOASTERS

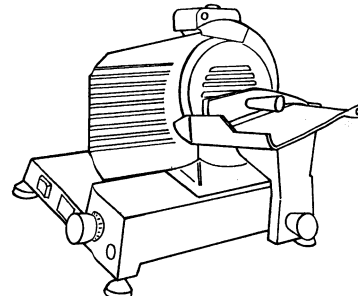

NOAW Slicers

Manufactured/Imported in Australia by:

**ROBAND<sup>®</sup>** 

Authorised Distributor/Agent