



HOSHIZAKI

DCM-120KE-P

Ice & Water Dispenser

PRODUCT FEATURES

- Premium Cubelet ice
- Smooth ice dispense
- No ice bridging
- Robust and reliable
- Sanitary self-service application
- Easy operation - Push button; dispense ice directly in to container greatly reducing risk of contamination
- Dispenses ice only, water only or ice and water
- Adjustable portion controlled dispensing
- Due to Auger system water consumption is equal to ice production.
- 2 year parts & labour on entire unit, 5 year (parts only) on compressor & air cooled condenser coil

TECHNICAL DRAWING

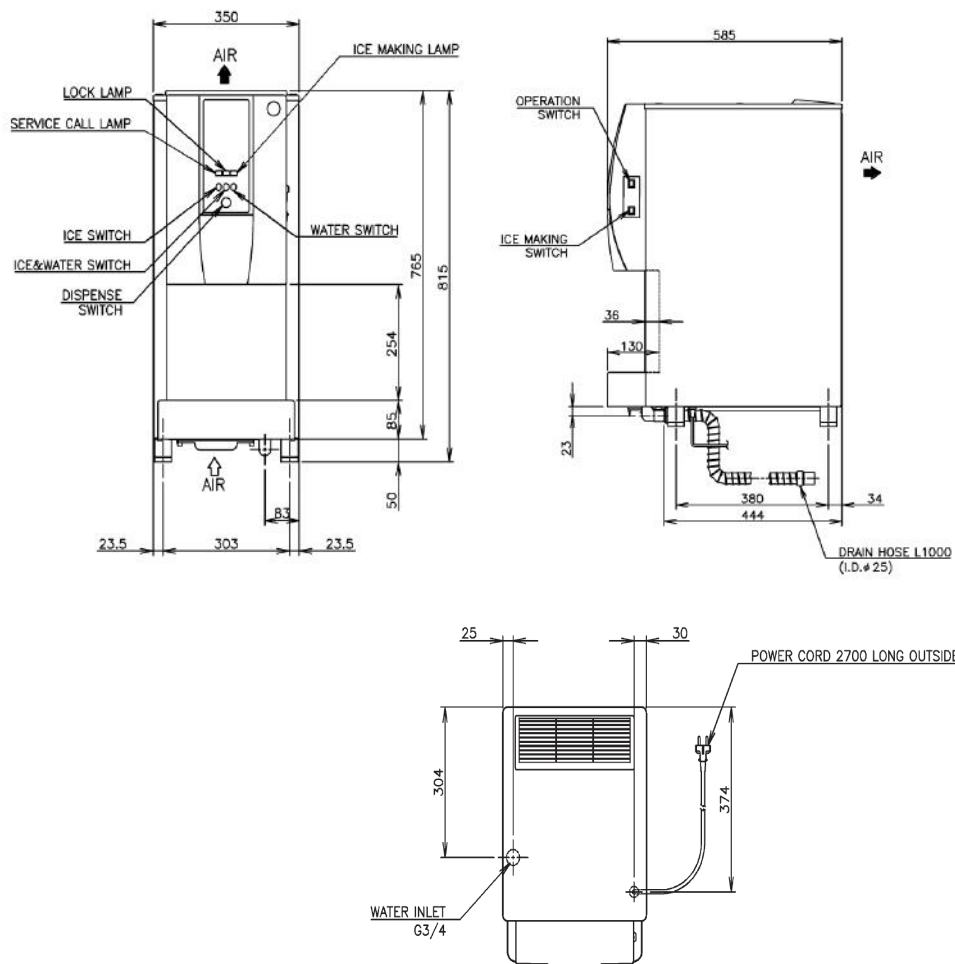

SHAPE OF ICE:



PRODUCT SPECIFICATION

Production Capacity per 24hours	Approx. 125kg @10°C Air temp; 10°C Water Approx. 105kg @ 21°C Air temp; 15°C water Approx. 85kg @ 32°C Air temp; 21°C water Approx. 4kg
Max Storage Capacity	350mm (W) x 585mm (D) x 815mm (H)
Dimensions	Air
Cooling	57 / 66
Weight Net/Gross (kg)	1 PHASE 220 - 240/10AMP Plug
AC Supply Voltage	Rated:2.8 / 2.7 A Starting: 12.6 A /10Amp Plug
Amperage	R134a
Refrigerant Charge	Ambient Temp.: 5-40°C
Operating Conditions	Water Supply Temp.: 5-35°C Water Supply Pressure: 0.07-0.8MPa Voltage Range: Rated Voltage ±6%



Descriptions and specifications are subject to change at any time, without notice. Illustrations for demonstration purposes.

Copyright © 2020 Hoshizaki Lancer Pty Ltd. All right reserved. E&OE Date: Sept 2020