

LA135LP

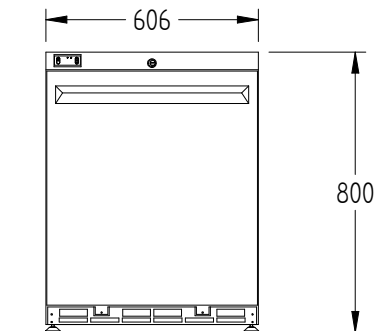

CATEGORY	FOODSERVICE SPECIALISED
RANGE	Amber
UNIT	FREEZER
TYPE	SELF CONTAINED
DOORS	1

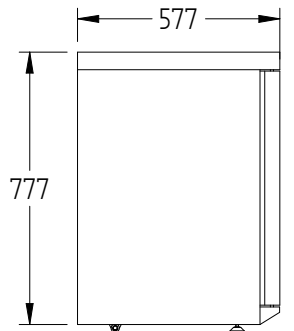
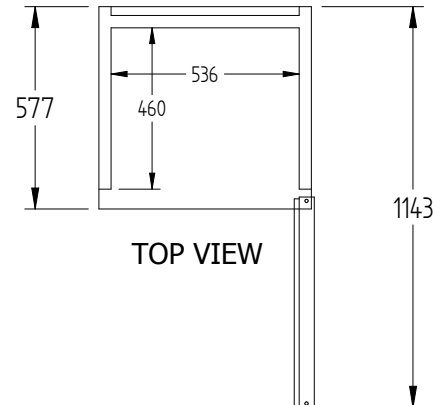

SPECIFICATIONS

CAPACITY LITRES	133
TEMPERATURE - (MANUAL DEFROST) - 32°C AMBIENT ENVIRONMENT	-18°C / -22°C
DIMENSIONS - W X D X H (ON CASTORS) MM	606 W x 577 D x 800 H
WEIGHT UNPACKED (KG)	55

STANDARD INCLUSIONS ***

DOOR TYPE	Standard: SD (Solid Door)
FINISH (INTERIOR AND EXTERIOR EXCLUDING REAR AND UNDER)	SS (Stainless Steel)
SHELVES	2 Fixed

ELECTRICAL

POWER SUPPLY	10 amp
POWER CABLE LENGTH (METRES)	2
RUNNING AMPS	1.2

GAS TYPE

REFRIGERANT	R404a
-------------	-------

*** For **OPTIONS** refer to the current Williams Price Guide