

COMMERCIAL REFRIGERATOR AND FREEZER *USER'S MANUAL*

Models: BBU500GV、BBU300GV

***PLEASE READ THE MANUAL THOROUGHLY PRIOR TO
EQUIPMENT SET-UP, OPERATION AND MAINTENANCE.***

INSTALLATION/ OPERATION

IMPORTANT!!! PLEASE READ BEFORE INSTALLATION

- If the unit has recently been transported please let unit stand still for a minimum of 24 hours before plugging it in.
- Make sure that the unit drops down to desired temperature before loading the unit with product.
- Make sure that there is proper ventilation around the unit in the area where it will operate.
- Make sure all accessories are installed (i.e. shelves, shelf clips, casters) before plugging the unit in.
- Please read through the manual in its entirety.

CABINET LOCATION GUIDELINES

- **Install the unit on strong and leveled surfaces**
 - unit may make unpleasant noises if surface is uneven
 - unit may malfunction if surface is uneven
- **Install the unit in an indoor, well-ventilated area**
 - unit performs more efficiently in a well-ventilated area
 - for best performance, please maintain clearance of 30 mm on the back of the unit
 - outdoor use may cause decreased efficiency and damage to the unit
- **Avoid installation in a high humidity and/or dusty area**
 - humidity could cause unit to rust and decrease efficiency of the unit
 - dust collected on condenser coil will cause unit to malfunction. Clean the condenser at least once a month with a brush or clean cloth
 - malfunction due to dirty condenser will void warranty
- **Select a location away from heat and moisture-generating equipment**
 - high ambient temperatures will cause the compressor to overwork, leading to higher energy bills and gradual breakdown of the unit
 - malfunction due to high ambient temperature will void warranty

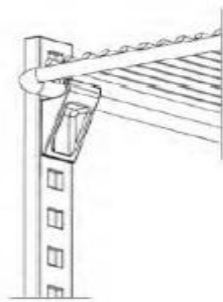

Figure 1.

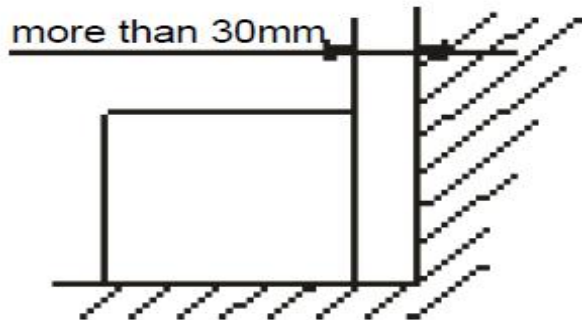

Figure 2.



Please dispose of all waste packaging appropriately and in accordance with all local recycling laws.

All electrical work must be carried out by suitably qualified persons

ELECTRICAL

Please ensure that the required voltage of the compressor is being supplied at all times. Low or high voltage can detrimentally affect the refrigeration unit.

All units should be plugged into a grounded and properly-sized electrical outlet with appropriate overcurrent protection. Please refer to the electrical requirements on the nameplate of the unit. Please make sure that your unit has its own dedicated outlet. Do not use an extension cord.

TEMPERATURE CONTROLS

The temperature controls are factory-set to maintain an average temperature of 0 C in refrigerators. To maintain a different temperature, simply adjust the thermostat is located at the control panel on the basis of operation manual inside of cabinet.

CAUTION

Setting the temperature control to the coldest setting may cause the evaporator coil to freeze and ice up. This will eventually result in a warmer cabinet temperature.

LOADING PRODUCT

Shelves have been factory-installed for your convenience. Before loading shelves, please be sure that all shelf clips are completely fastened in their correct locations. It is important that all shelves rest completely level before stocking your cabinet with product. In order to maintain correct air flow inside the unit, please be sure to leave 50 mm to 100 mm of space between the back wall and stored product. Blocking the evaporator fans will result in a warmer cabinet temperature, and ultimately compressor failure.



WARNING

Do **NOT** exceed the maximum shelf loading weight of 25kg per shelf, so as to avoid injury and/or damage.

DEFROST SYSTEMS

Refrigerator coils are kept below the freezing point (0 C). During compressor down-time, the evaporator fan continues to circulate air through the evaporator coil. This air circulation raises the coil temperature above the freezing point, melting any accumulated frost. Run-off water is drained into the evaporator pan and evaporated.

PLEASE NOTE: Excessive door openings should be avoided in order to maintain cabinet temperature and to eliminate the possibility of coil freeze-up.

SAFETY / WARNING

Please pay close attention to the safety notices in this section. Disregarding these notices may lead to serious injury and/or damage to the unit.

ATTENTION

- To minimize shock and fire hazards, be sure not to overload outlet. Please designate one outlet for your unit.
- Do not use extension cords.
- Do not put your hands under the unit when the unit is required to be moved.
- When the unit is not in use for a long period of time, please unplug the unit from the outlet.
- After unplugging the unit, wait at least 10 minutes before re-plugging it. Failure to do so could cause damage to the compressor.

UNPLUG CORD

- To minimize shock and fire hazards, please do not plug or unplug the cord with wet hands.
- During maintenance and cleaning, please unplug the unit.

PROPER GROUNDING REQUIRED

- To minimize shock and fire hazards, make sure that the unit is properly grounded.

PROHIBITION

- Do not attempt to remove or repair any component unless instructed by factory.
- Make sure that the unit is not resting on or against the electrical cord and plug.
- To minimize personal injury, do not hang on the doors.
- Do not store any flammable and explosive gas or liquids inside the unit.
- Do not attempt to alter or tamper with the electrical cord.

REGULAR MAINTENANCE

CLEANING THE CONDENSER COIL

- For efficient operation, it is important that the condenser surface be kept free of dust, dirt, and lint.
- We recommend cleaning the condenser coil and fins at least once per month.
- Clean with a commercial condenser coil cleaner, available from any kitchen equipment retailer. Brush the condenser fins from top to bottom, not side to side.
- After cleaning, straighten any bent condenser fins with a fin comb.

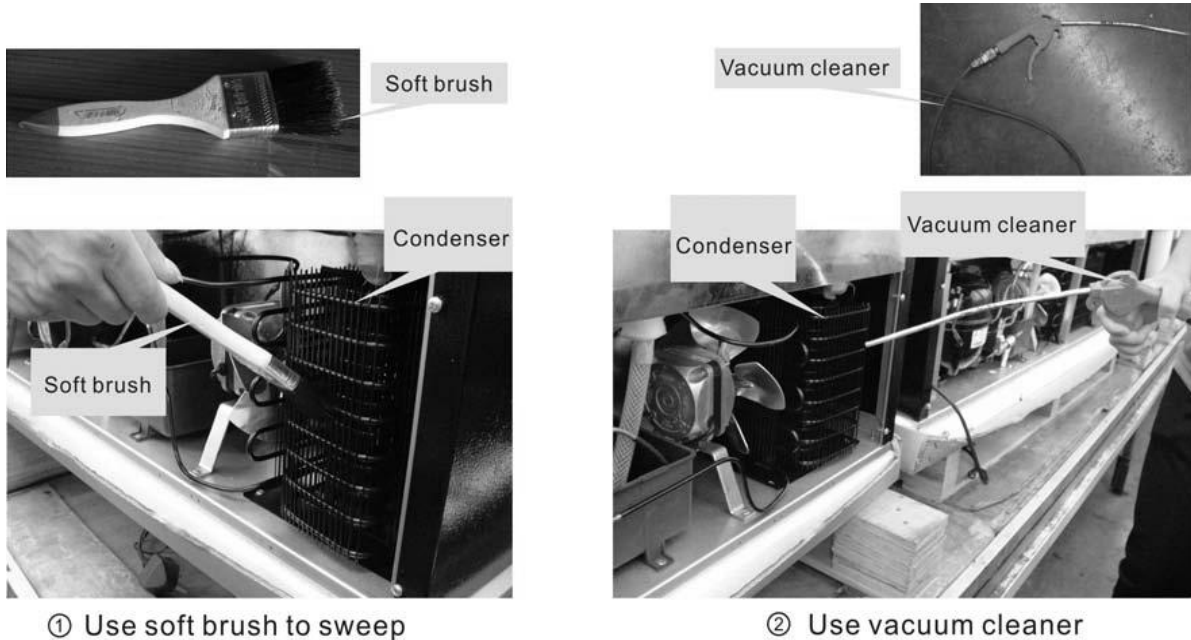

CLEANING THE FAN BLADES AND MOTOR

If necessary, clean the fan blades and motor with a soft cloth. If it is necessary to wash the fan blades, cover the fan motor to prevent moisture damage.

CLEANING THE INTERIOR OF UNIT

- When cleaning the cabinet interior, use a solvent of warm water and mild soap.
- Do not use steel wool, caustic soap, abrasive cleaners, or bleach that may damage the stainless steel surface.
- Wash door gaskets on a regular basis, preferably weekly. Simply remove door gasket from the frame of the door, soak in warm water and soap for thirty (30) minutes, dry with soft cloth, and replace.
- Check door gaskets for proper seal after they are replaced.
- Periodically remove the shelves and pilasters from the unit and clean them with mild soap and warm water. To remove the pilasters, first remove the shelves and shelf brackets. Then, simply lift the pilaster up and out.

WARNING

Disconnect power cord before cleaning any parts of the unit.

TROUBLE SHOOTING

Before requesting any service on your unit, please check the following points. Please note that this guide serves only as a reference for solutions to common problems.

SYMPTOM	POSSIBLE CAUSE	CORRECTIVE ACTION
Compressor not running.	Fuse blown or circuit breaker tripped. Power cord unplugged. Thermostat set too high. Cabinet in defrost cycle.	Replace fuse or reset circuit breaker. Plug in power cord. Set thermostat to lower temperature. Wait for defrost cycle to finish.
Condensing unit runs for long periods of time.	Excessive amount of warm product placed in cabinet. Prolonged door opening or door ajar. Door gasket(s) not sealing properly. Dirty condenser coil. Evaporator coil iced over.	Allow adequate time for product to cool down. Ensure doors are closed when not in use. Avoid opening doors for long periods of time. Ensure gaskets are snapped in completely. Remove gasket and wash with soap and water. Check condition of gasket and replace if necessary. Clean the condenser coil. Unplug unit and allow coil to defrost. Make sure thermostat is not set too cold. Ensure that door gasket(s) are sealing properly.
Cabinet temperature is too warm.	Thermostat set too warm. Blocking air flow. Excessive amount of warm product placed in cabinet. Fuse blown or circuit breaker tripped. Dirty condenser coil. Prolonged door opening or door ajar. Evaporator coil iced over.	Set thermostat to lower temperature. Re-arrange product to allow for proper air flow. Make sure there is at least 50 mm of clearance from evaporator. Allow adequate time for product to cool down. Replace fuse or reset circuit breaker. Clean the condenser coil. Ensure doors are closed when not in use. Avoid opening doors for long periods of time. (see above)
Cabinet is noisy.	Loose part(s). Tubing vibration.	Locate and tighten loose part(s). Ensure tubing is free from contact with other tubing or components.