

Freestanding Hotplate/Grill



The electric Austheat hotplate griller is the ideal solution for busy fast food outlets where high speed grilling and toasting is required. Ideal as a hamburger or grill station, the Austheat hotplate/griller is designed to work either as a stand alone machine or alongside Austheat deep fryers in a modular configuration.

FEATURES

AHT860 with toasting or salamander function:

- The grill below the hotplate has a dedicated element for perfect one-sided toasting or salamander function. This is unlike many other brands available in the market that use the heat from the hotplate surface for toasting, which can result in uneven toasting. The heat output of the toaster is controlled by an energy regulator.
- The toaster also has a cook/idle setting. The twin energy regulator controls enable one heat setting to cook and another heat setting for idle periods so the chef can quickly switch between high and low settings in busy or quiet periods. It additionally provides a backup in the unlikely instance of a primary energy regulator failure.
- Each of the two cooking surface sections is controlled by it's own cook/idle switch. Each cook/idle switch has two thermostats - one to control the temperature when switched to "Cook" and the other to control the temperature when switched to "Idle". This feature allows the Chef to quickly turn the temperature of the machine up to "Cook" and down to an "Idle" heat setting in quieter times to conserve electricity. The twin thermostat has the added benefit of providing a backup in the unlikely event of a primary thermostat failure.
- Easily readable twin digital temperature displays depict plate temperature.



AHT860



AH860

AH860 with extra storage space:

- The extra storage space under the steel hotplate is ideal for storing plates or cooking materials.
- Removable shelf for easy cleaning – 3 step adjustment

Both the AH860 & AHT860:

- A 12 mm thick heavy-duty machined steel hotplate cooking surface, providing the temperature and heat retention required for efficiently cooking a variety of grilled foods such as hamburgers, steak, eggs, bacon and pancakes. Features separate controls for the left side and right side of the hotplate providing flexibility in the use of the cooking surface area and ability to conserve electricity by only heating the cooking surface space required.
- Castors on the rear and adjustable legs at the front.



FEATURES

AHT860 Cook/idle switches. Left controls 2/3 of plate, right controls 1/3 of plate



AHT860 Twin digital displays. One for each side of the hotplate



AHT860 toasting section is controlled by a separate energy regulator



SPECIFICATIONS

MODEL	HOTPLATE POWER	TOASTER POWER	TOTAL POWER	TOTAL CURRENT Amps	PHASE	COOKING PLATE AREA	APPROX. TOASTING AREA	TOASTING HEIGHT CLEARANCE
AHT860	10.5 kW	1.7 kW	12.5 kW	54.5	3 (+N)	645 x 585 mm	490 x 410 mm	135 mm
AH860	10.5 kW	N/A	10.5 kW	45.7	3 (+N)	645 x 585 mm	N/A	N/A

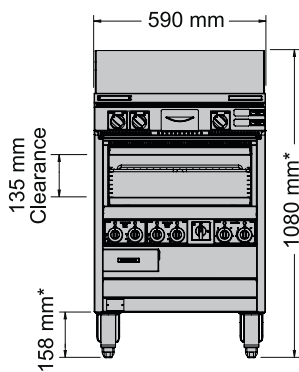

AHT860

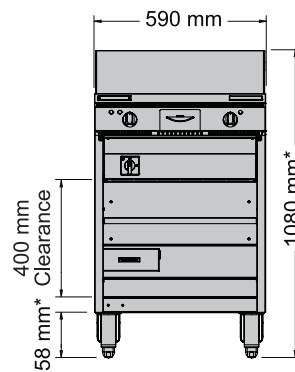

AH860

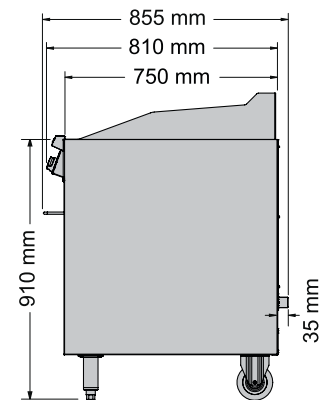

AHT860 & AH860

* Varies with foot adjustments.

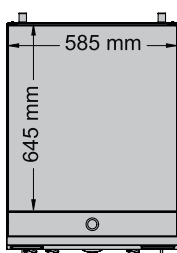

Hotplate for AHT860 & AH860

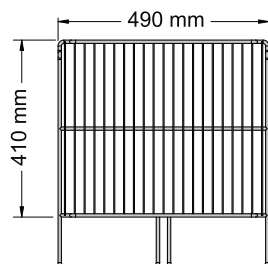

Toaster Rack for AHT860

