

# Z/TA

## Appearance Package



### Prep and Installation Manual

rev 1.0

ZTACars.com

Woodwardspeedshop.com

2020 PMD Automotive  
Woodward Speed Shop

### Camaro Panel Removal Instructions

Rear Spoiler Removal	1
Rear Bumper Cover Removal	2
Front Bumper Cover Removal	3
Hood Removal	5
Rocker Panel Removal	6
Front Fender Removal	7

### Z/TA Panel Assemblies & Installations

Convertible Spoiler Assembly	8
Rear Spoiler Installation	10
Rear Bumper Cover Assembly	11
Rear Bumper Installation	13
Rear Bumper Cover Installation	15
Front Fender Installation	17
Fender Air Extractor Install	18
Rocker Panel Installation	19
Front Bumper Cover Assembly	20
Front Bumper Cover Installation	23
Shaker Scoop Assembly	25
Shaker Scoop Installation	26
Hood Assembly (prior to mounting)	28
Hood Installation	29

# Rear Spoiler Removal

Remove 4 cap plugs.



Remove Trim Panel



Remove M10 bolts.

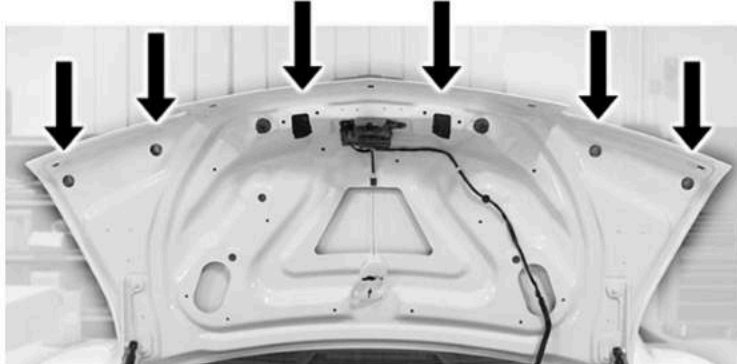

Remove spoiler from car.



# Rear Bumper Cover Removal

Lift car and remove rear wheels. (Follow manufacture's guidelines for wheel removal).

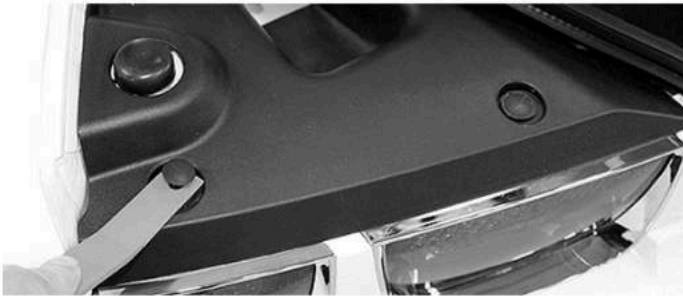

Remove LH and RH tail lamp access covers.



Disconnect LH and RH wire harness.

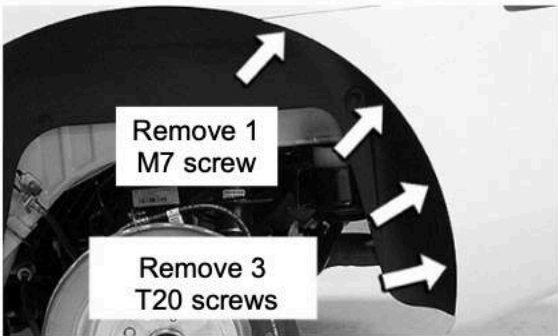

Peel away cover from body.

Hold with two hands as shown.  
Pull swiftly rearward,  
until snaps disengage.  
  
Repeat on other side.



Pull straight  
back swiftly.

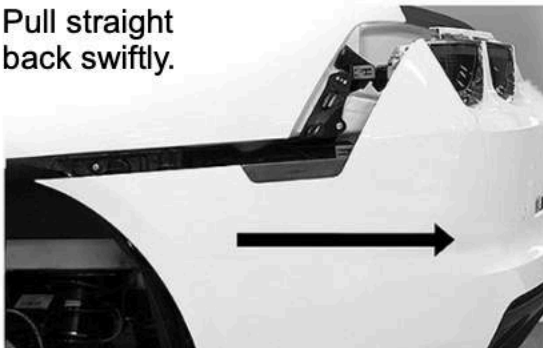

Remove  
bumper cover.



# Front Bumper Cover Removal

Lift car and remove front wheels. (Follow manufacture's guidelines for wheel removal).  
Remove wheel liner.

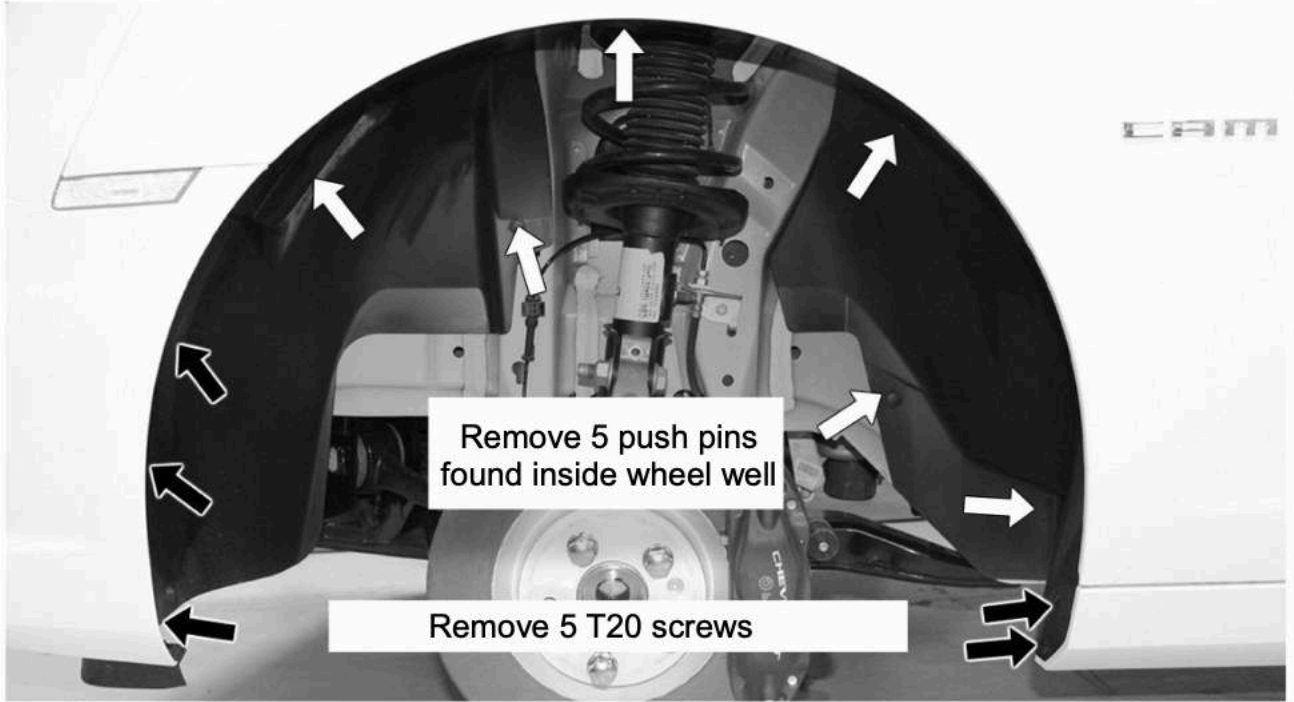

(LH side shown. Repeat on RH side)

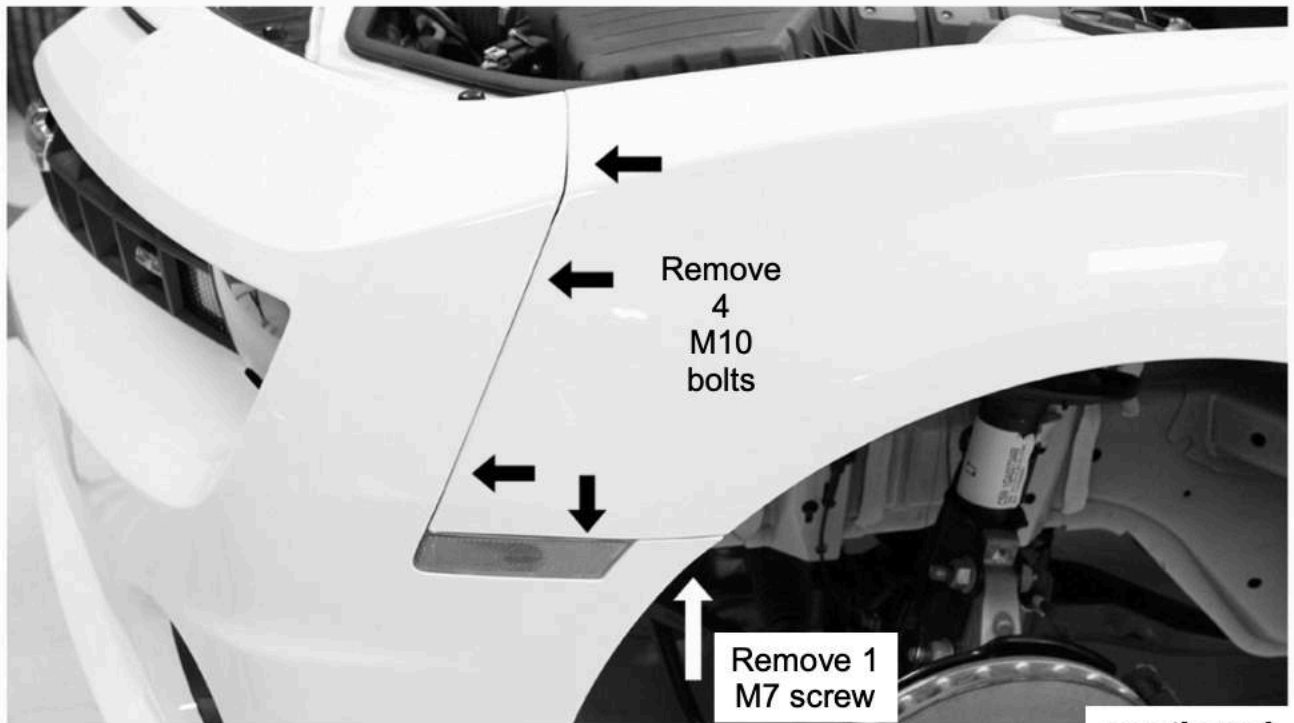

*continued*

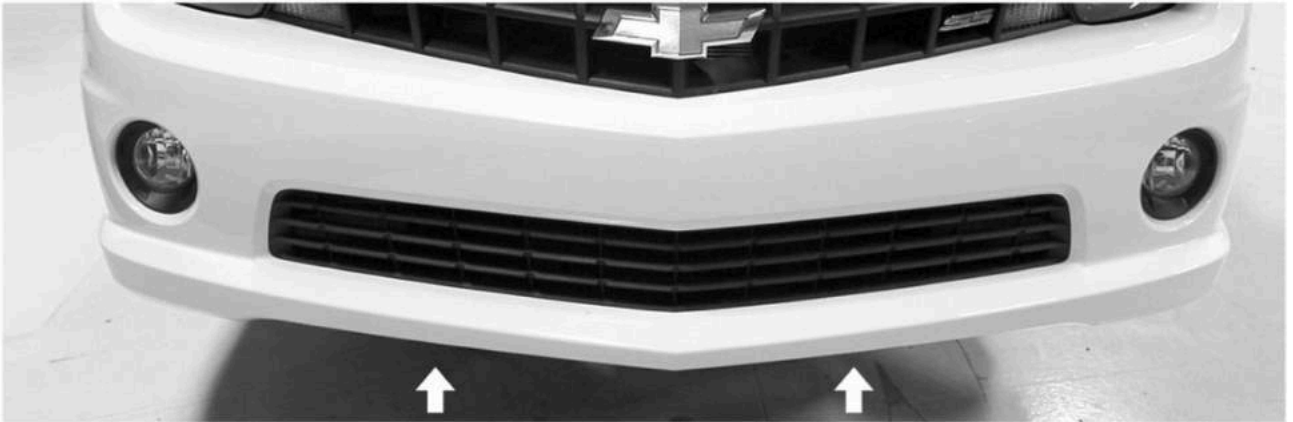

Remove 2 M10 bolts from underneath bumper cover.

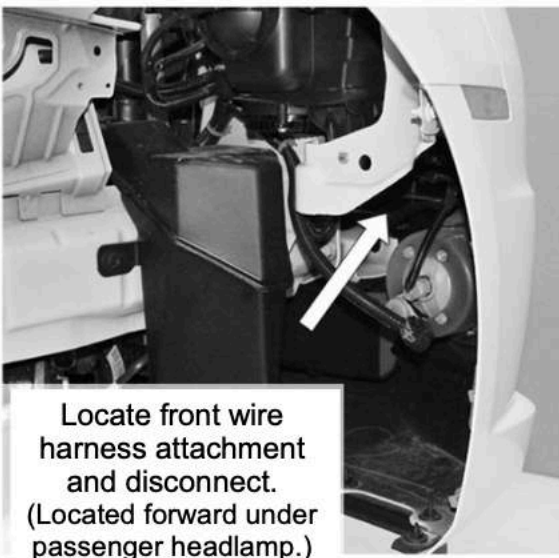
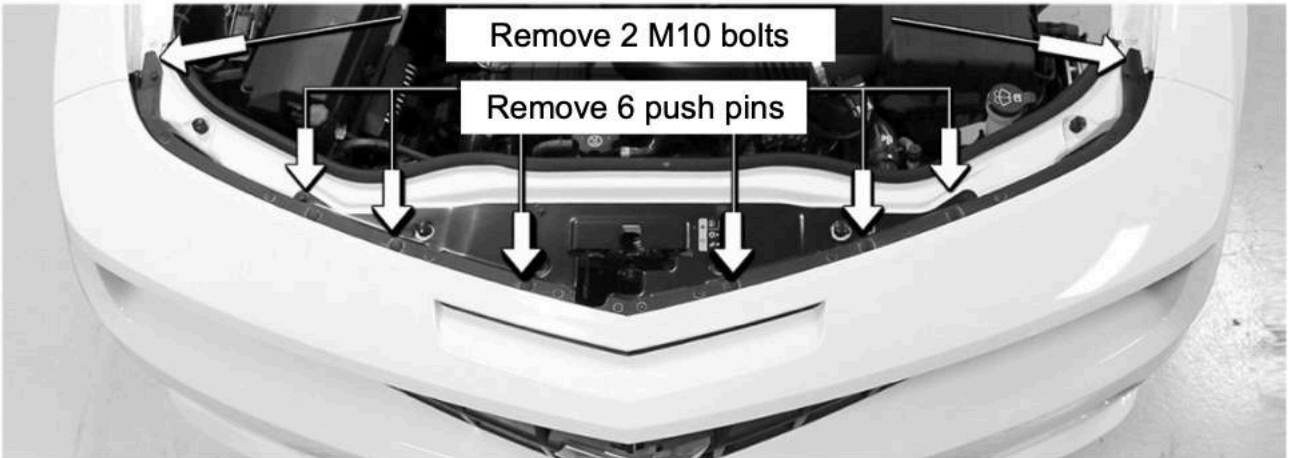

Locate front wire harness attachment and disconnect.  
(Located forward of passenger headlamp.)

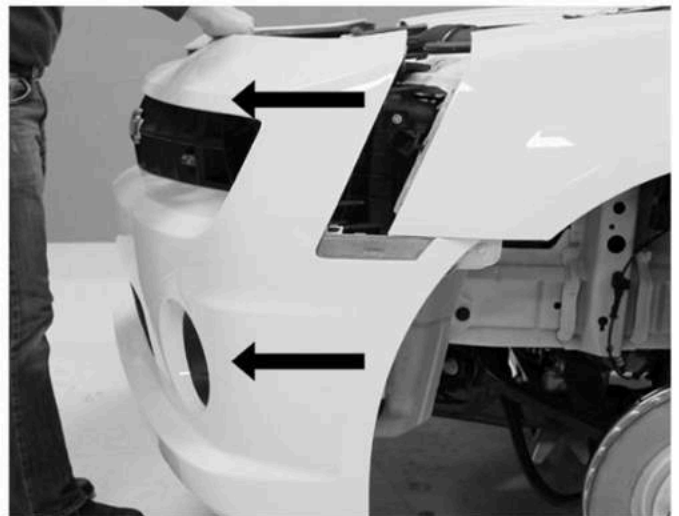

Lift slightly and pull forward for removal.

Unclip washer hose from cowl panel and disconnect hood hose from body.

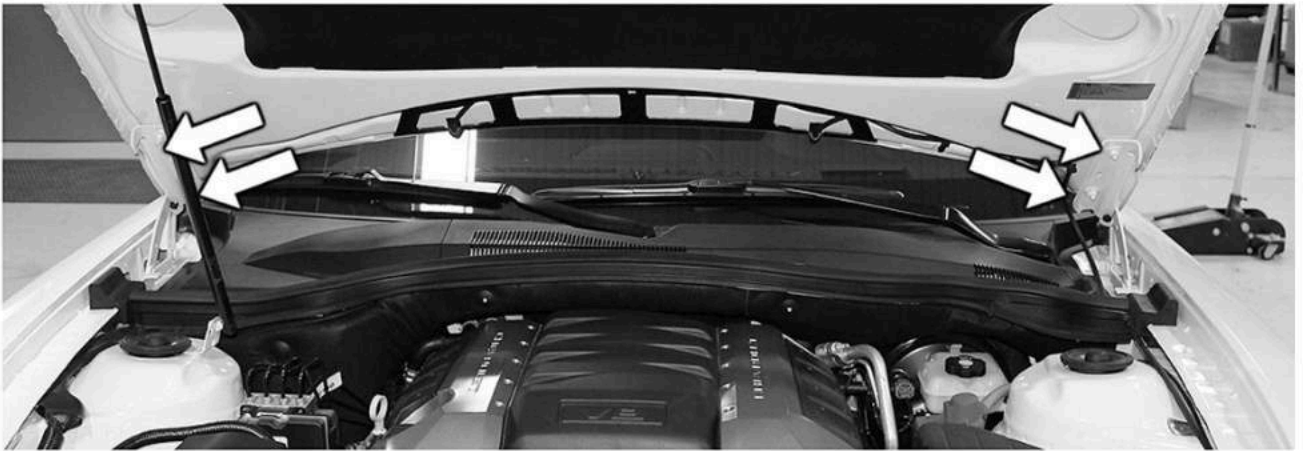

Remove 4 M13 hinge bracket nuts.



Disconnect hood prop strut from hood.



Remove hood from car.

# Rocker Panel Removal



Clip removal tool is required.

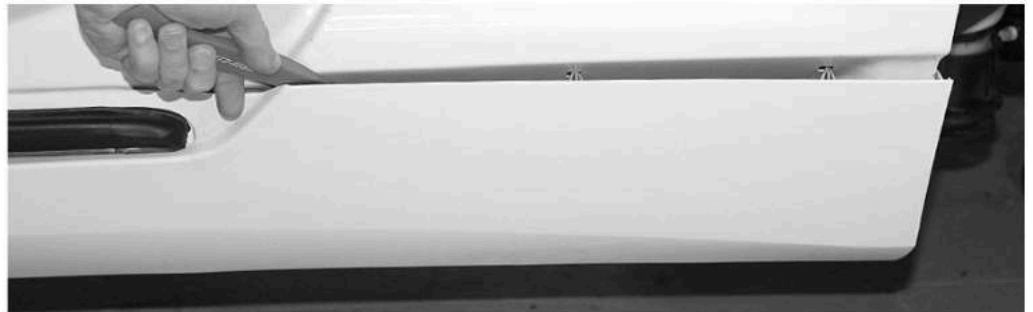

It is best to start at the rear and unclip moving forward.



After top row of clips have been released, reach down in and release the bottom row of clips.



Remove rocker panel.



Be very careful in removal so as to not break clips

# Front Fender Removal

Remove 8 M10 bolts

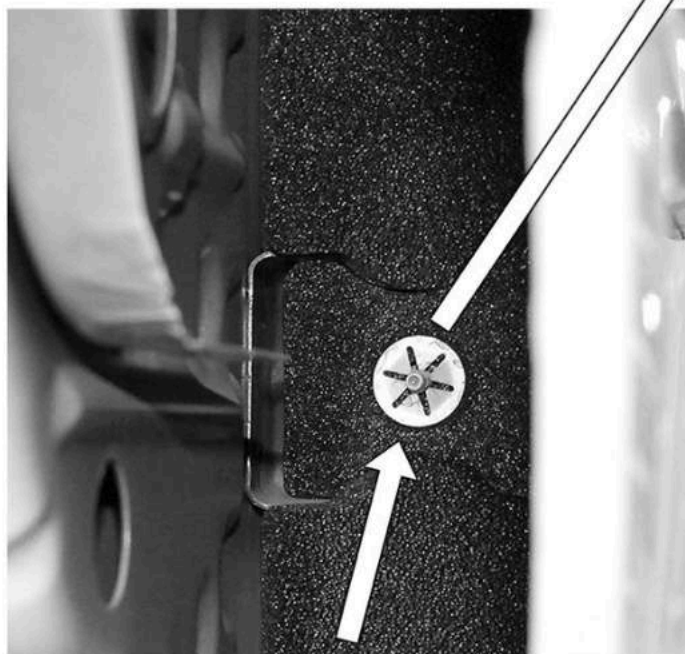
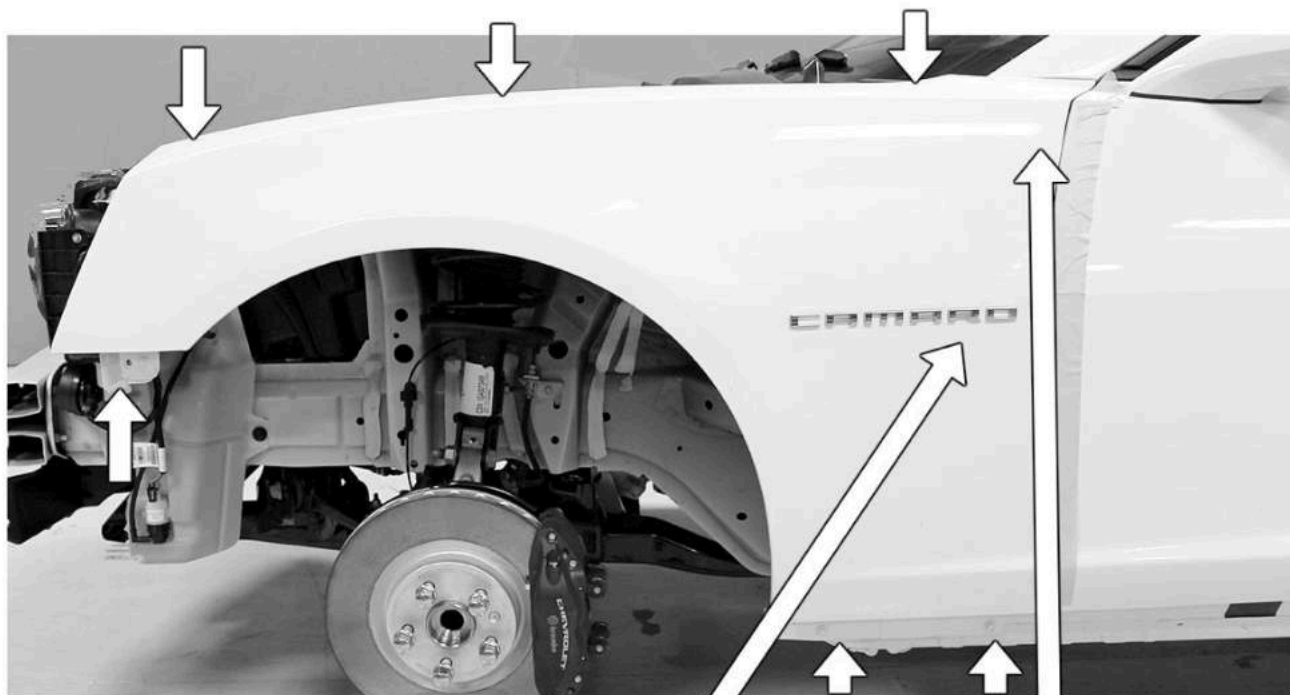

Remove star clip and insulator.  
Loosen the M10 nut for fender removal.



Open door and remove M10 bolt.



# Convertible Antenna (only) Spoiler Assembly

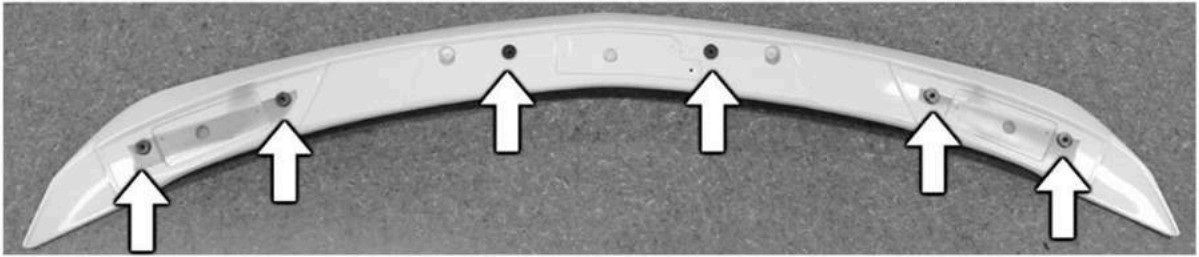

Peel back paper and stick foam washers over the mounting attachments on back of spoiler. Make sure washers are centered and not to interfere with bolts.

Lay the Camaro spoiler on a soft surface and remove three access plates.

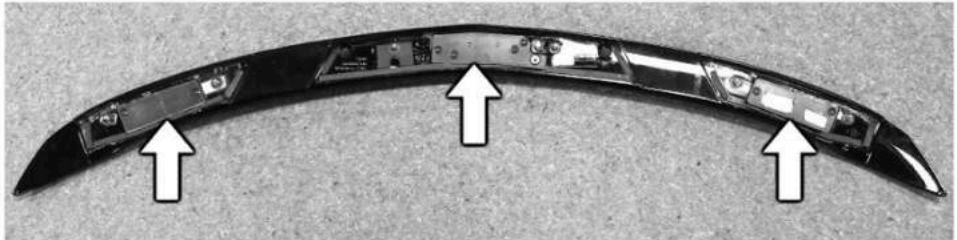

Disconnect and remove the antenna wires.

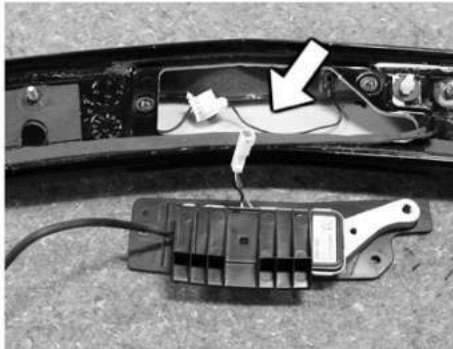

Remove two long push pins found on each side of the center antenna.

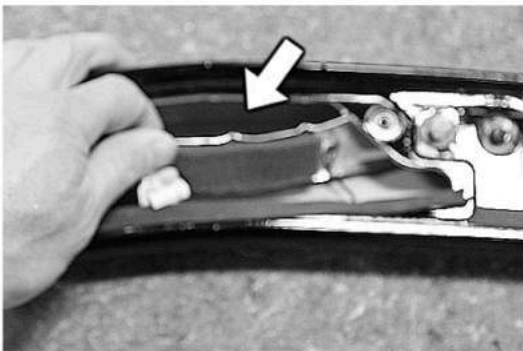

Gently, pull up the antenna strip in the middle until you are able to pull the right end up and out of the access hole.



Push the center back down and slide out the entire antenna strip.

# Convertible Antenna (only) Spoiler Assembly

Slide the antenna strip into the new spoiler as shown.



Insert the supplied foam blocks as shown.



Reinstall each end plate. Pushing the plate in will compress the foam block and keep the antenna stationary inside the spoiler. Replace the screws. Do not over tighten.

Re connect the antenna and route the vehicle connectors thru the hole as shown, replace the mounting screws do not over tighten.



Apply the supplied foam washers to the mounting points.



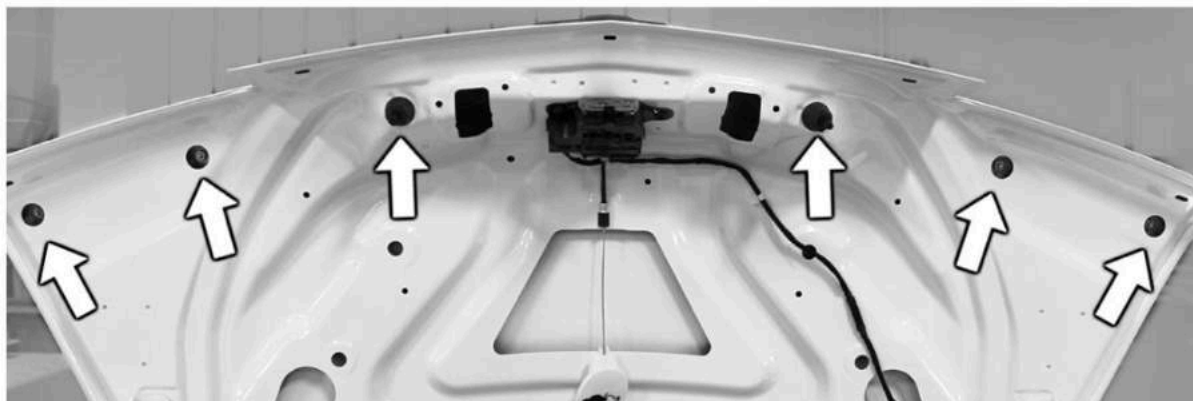

Attach the spoiler to the car using the 6 new M6 T30 bolts.



Reinstall trim panel and cap plugs.



# Rear Bumper Cover Assembly

Place Camaro bumper cover on a soft protective surface.

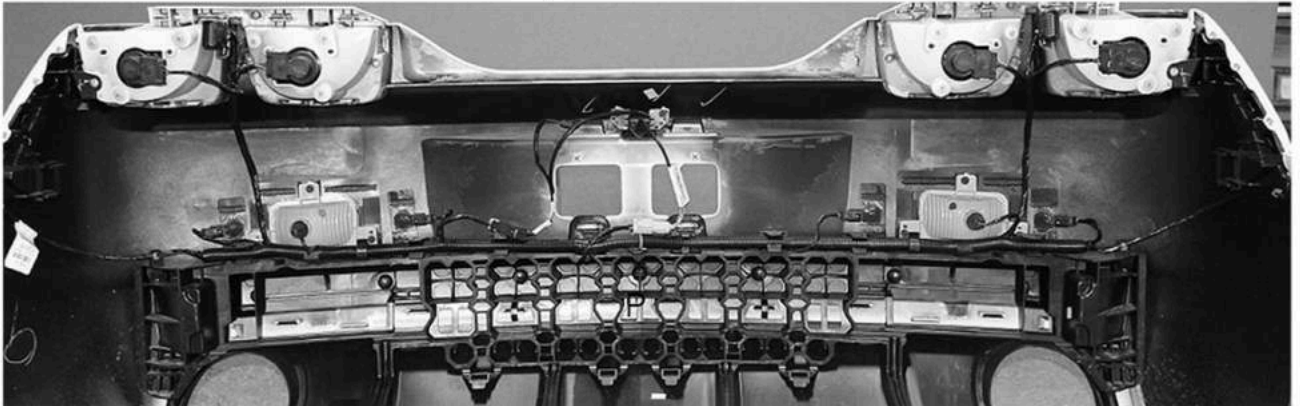

Unplug all bulbs and back up sensors. Remove harness from absorber and set aside. It will be reinstalled into new bumper cover.

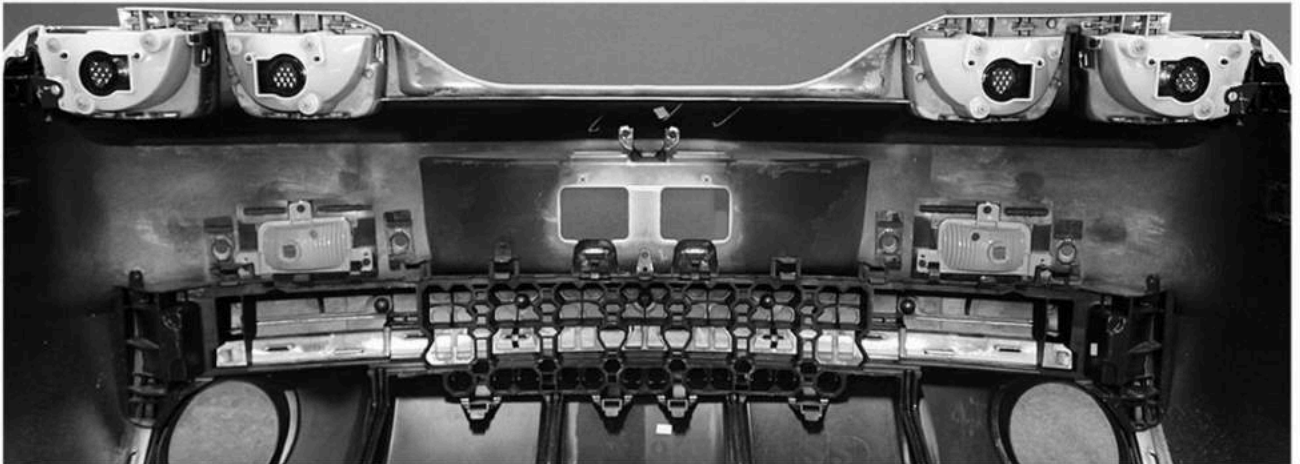

Remove Energy absorber so that it can be trimmed for reinstallation. Remove back-up lamps, side marker, lower bumper trim panel and all mounting screw clips. All will be remounted in the new cover.

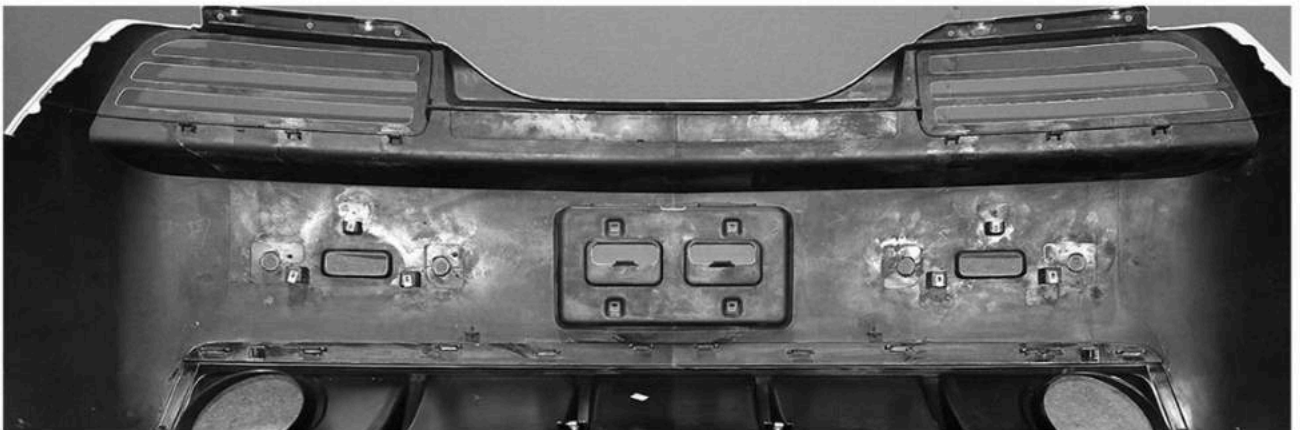

Snap lower trim panel into new bumper cover. Install all screw clips that were removed from Camaro assembly.

***continued***

## Rear Bumper Cover Assembly *continued*

You will need to cut out the rear bumper absorber to clear the rear license plate depression in the ZTA rear bumper, but make sure to keep upper attachments intact. See trim area Below for before and after comparison.

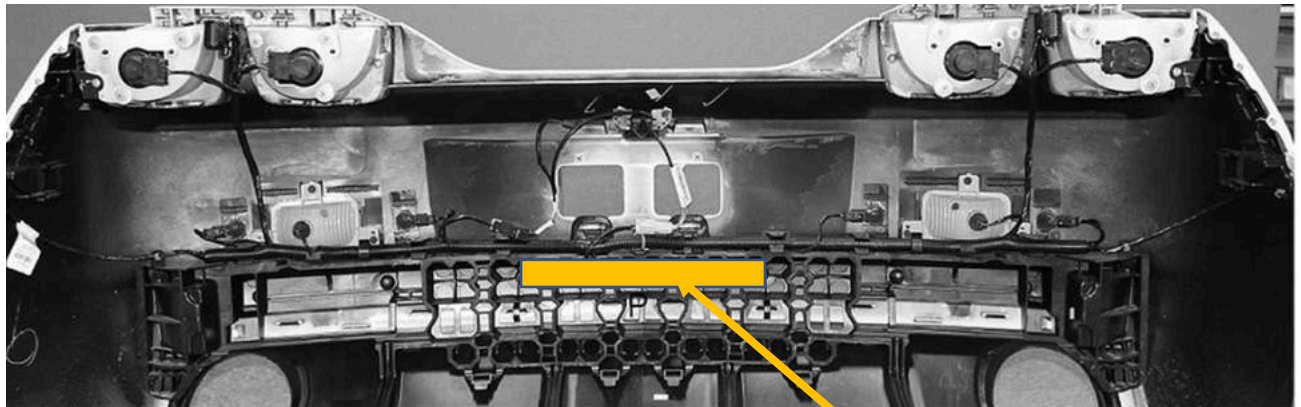
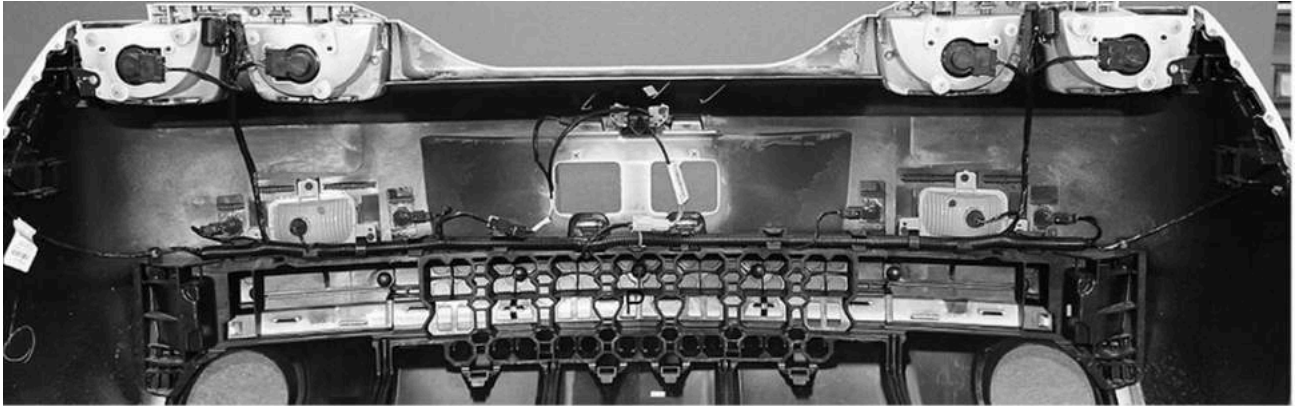

Trim out

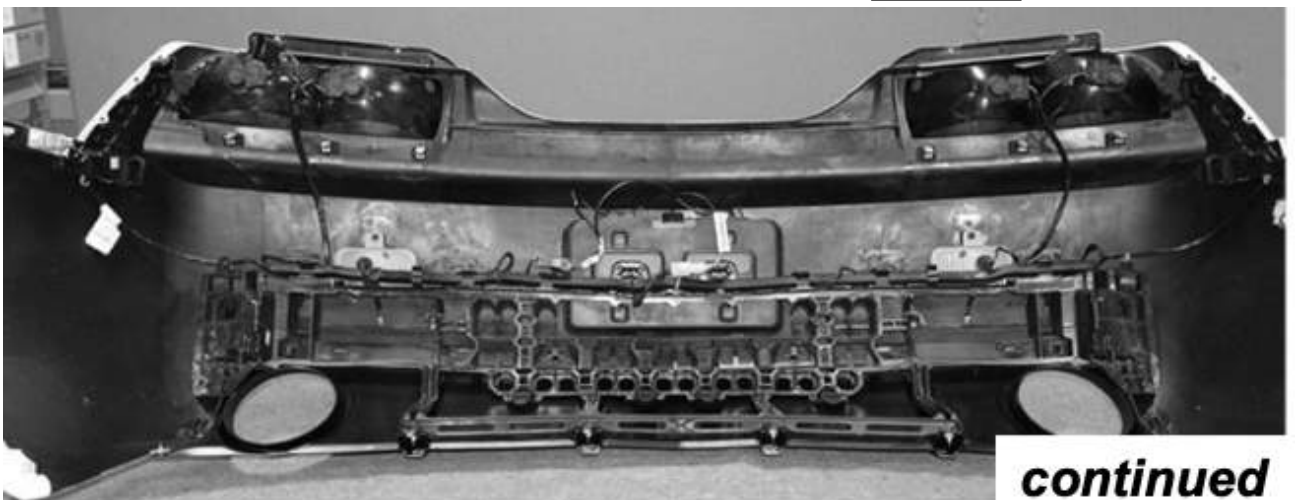

***continued***

## Rear Bumper Cover Assembly *continued*

If your car is equipped with a rear back-up camera, remove the camera from its bracket. Install new bracket and attach with rivets as shown.

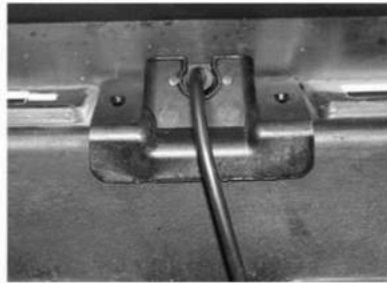
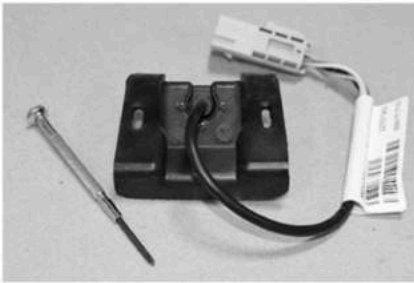

### Tail lamp installation:

Practice fit lamp assembly prior to removing mounting tape strips.

Ensure lamp is centered in opening.

Remove red tape strips and install lamp as shown.

Make sure bumper cover is clean and free from grease and dust so that the tail lamp tape will completely adhere.

Attach with 3 M6 T30 screws and nuts.

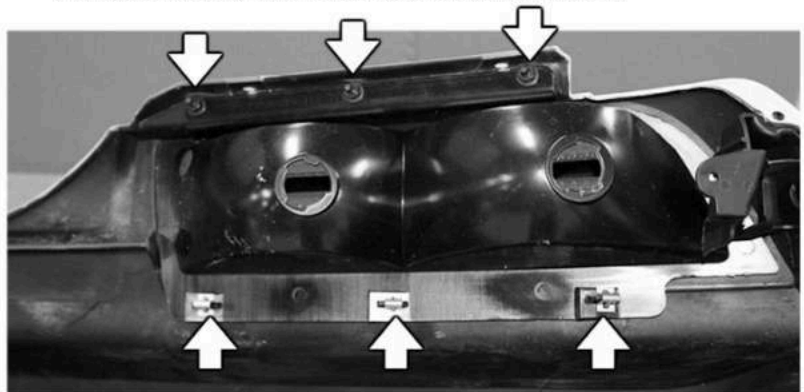

Support outside of cover. Push clips on firmly until lamp is tight to bumper cover.

Firmly press cover bars to lamp to ensure the tape is fully adhered to bumper cover.



Reinstall back-up lamps and side marker lamps.

Install new bumper absorber  
Reinstall wire harness to absorber.

Snap in the back-up sensors.  
Make all lamp connections.  
Install license plate lamps.  
Connect back up camera.

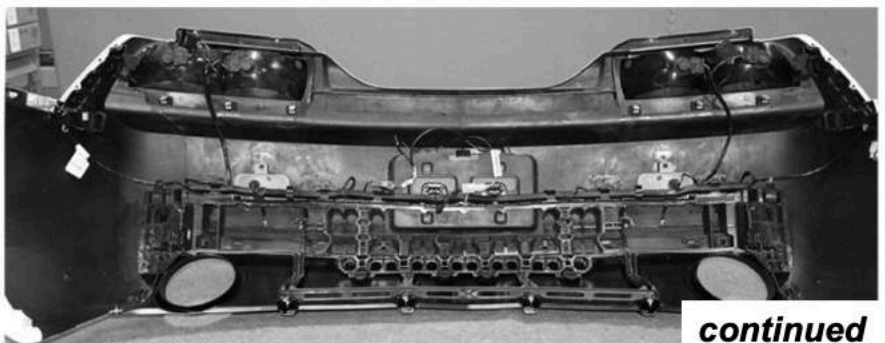

***continued***

# Rear Bumper Installation

## Rear Bracket

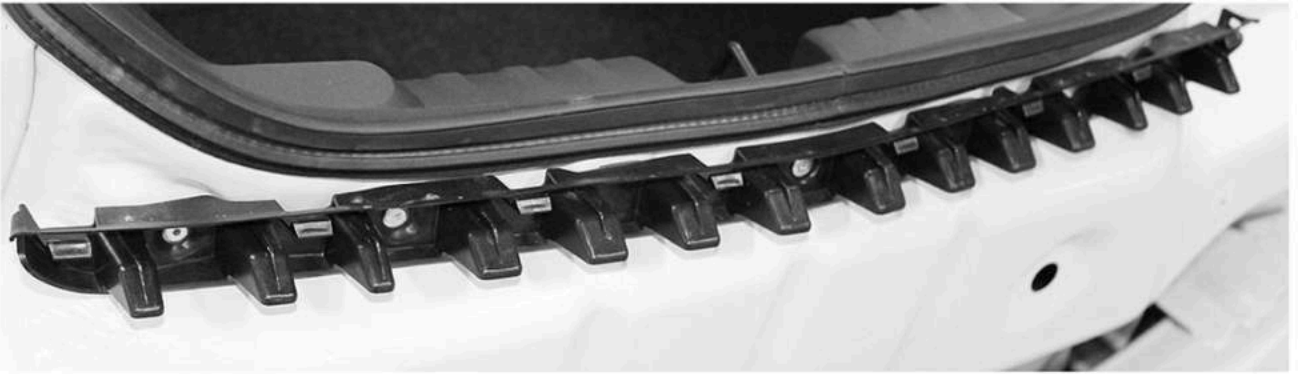

Trim back all 14 teeth to line shown.

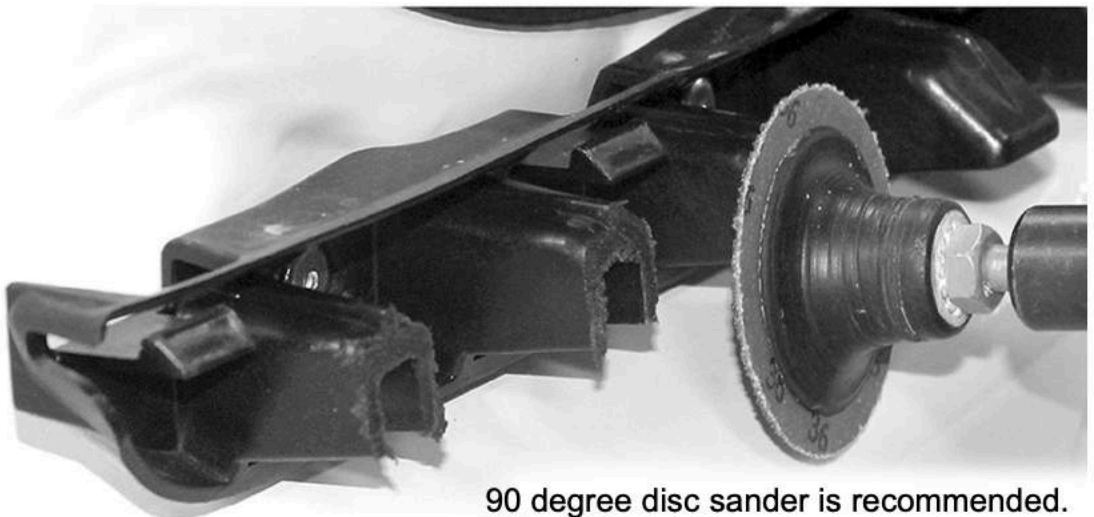
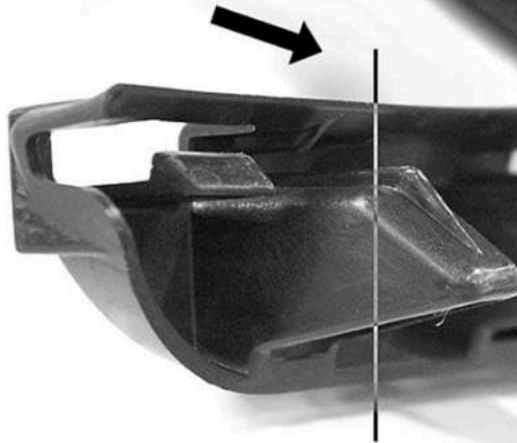

90 degree disc sander is recommended.

***continued***

# Rear Bumper Installation *continued*

Rear sheet metal modification required in areas outlined.

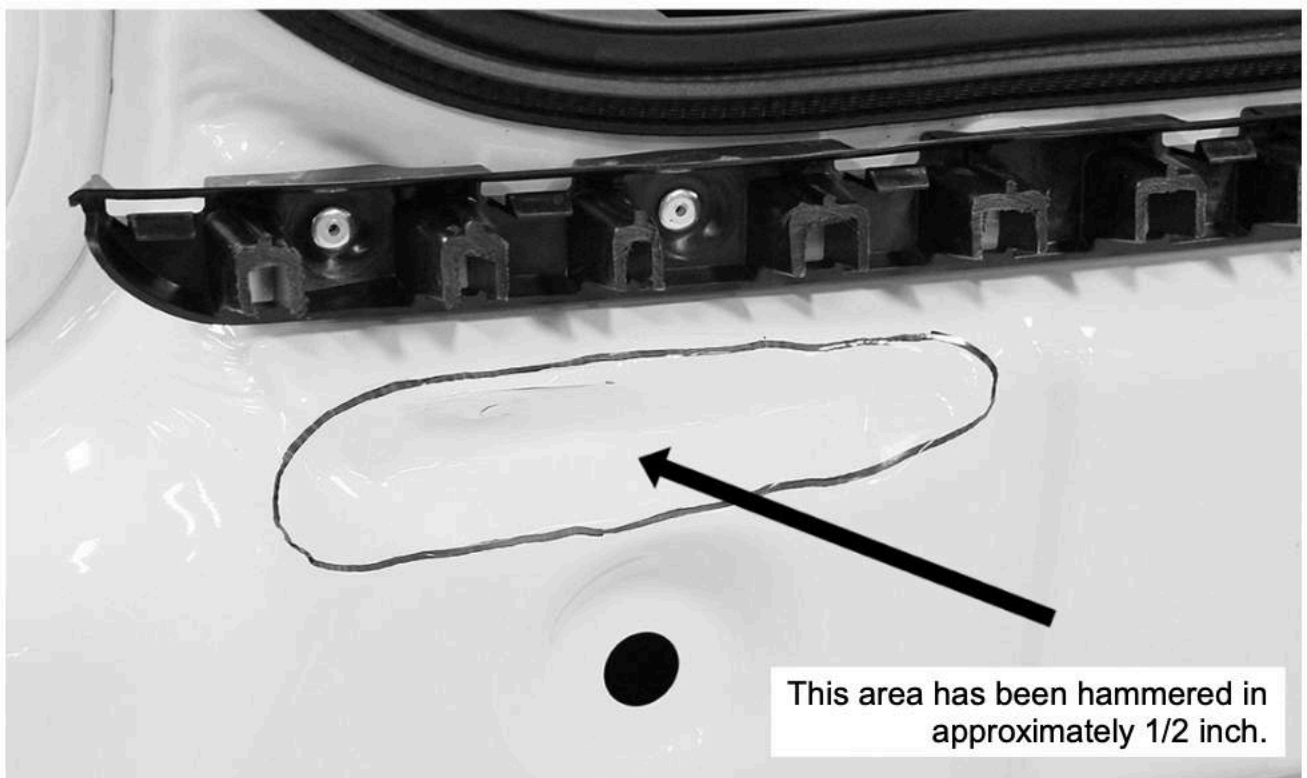



# Rear Bumper Cover Installation

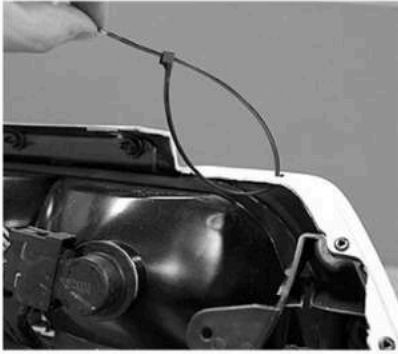

Attach one supplied tie strap through hole in cover as shown. Leave strap in big loop as shown and repeat on the other side

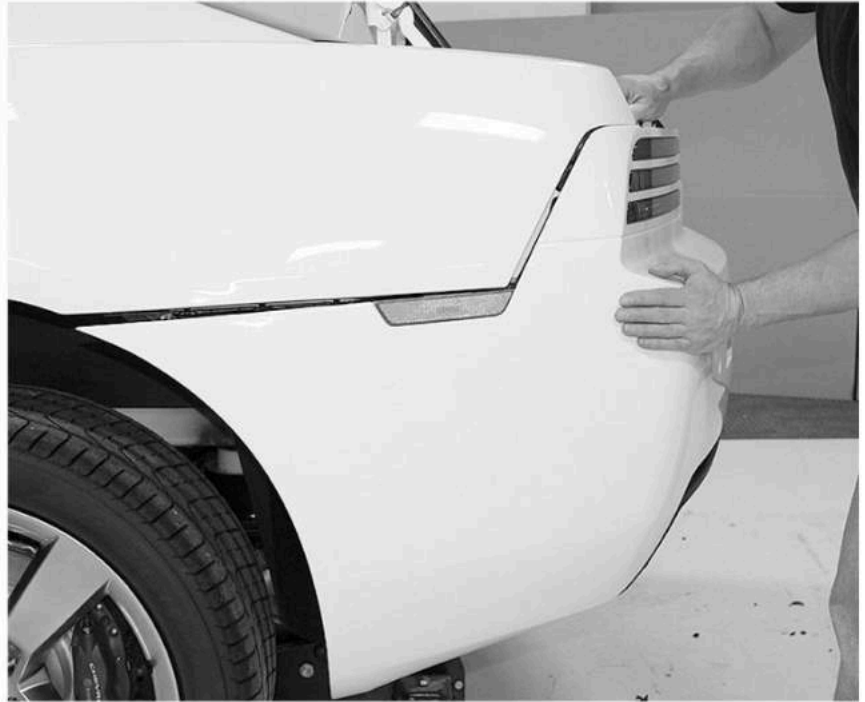

Install new bumper assembly to car. Center the cover and snap in each corner. Push in flange area along the lower quarter panel, as well as mounting flange between the tail lamps.



Make sure absorber is sitting correctly on the car's steel bumper. The absorber tabs have tendencies to get caught bent down in this area.

***continued***

## Rear Bumper Cover Installation *continued*

Reach in above tail lamps and find the tie strap loop that was previously installed.

Attach the second supplied tie strap through the loop and the cover attachment hole as shown.



**before**

Push in cover until slightly under and flush with sheet metal. Pull on tie strap until snug. This will ensure a proper fit now and during thermal expansion in high heat exposure.

**after**



Make tail lamp connection on both sides.  
Reinstall the covers.



# Front Fender Installation

Install new fender by replacing all 8 M10 bolts that were previously removed.

Applying protective tape along door edge is recommended to avoid chips and scratches.

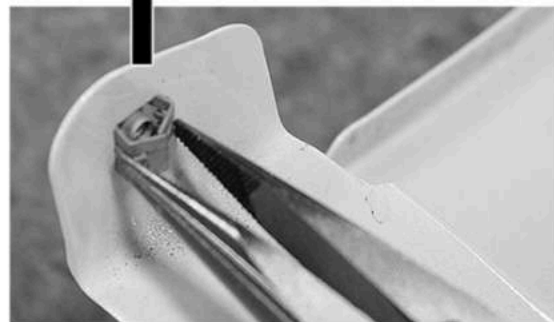
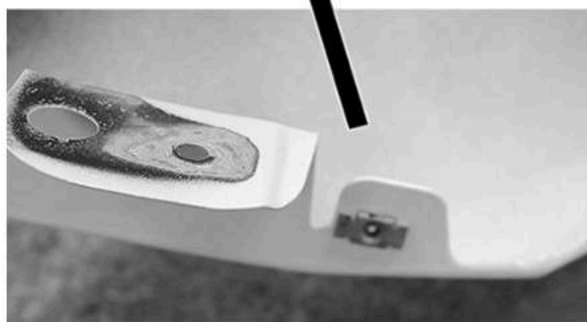
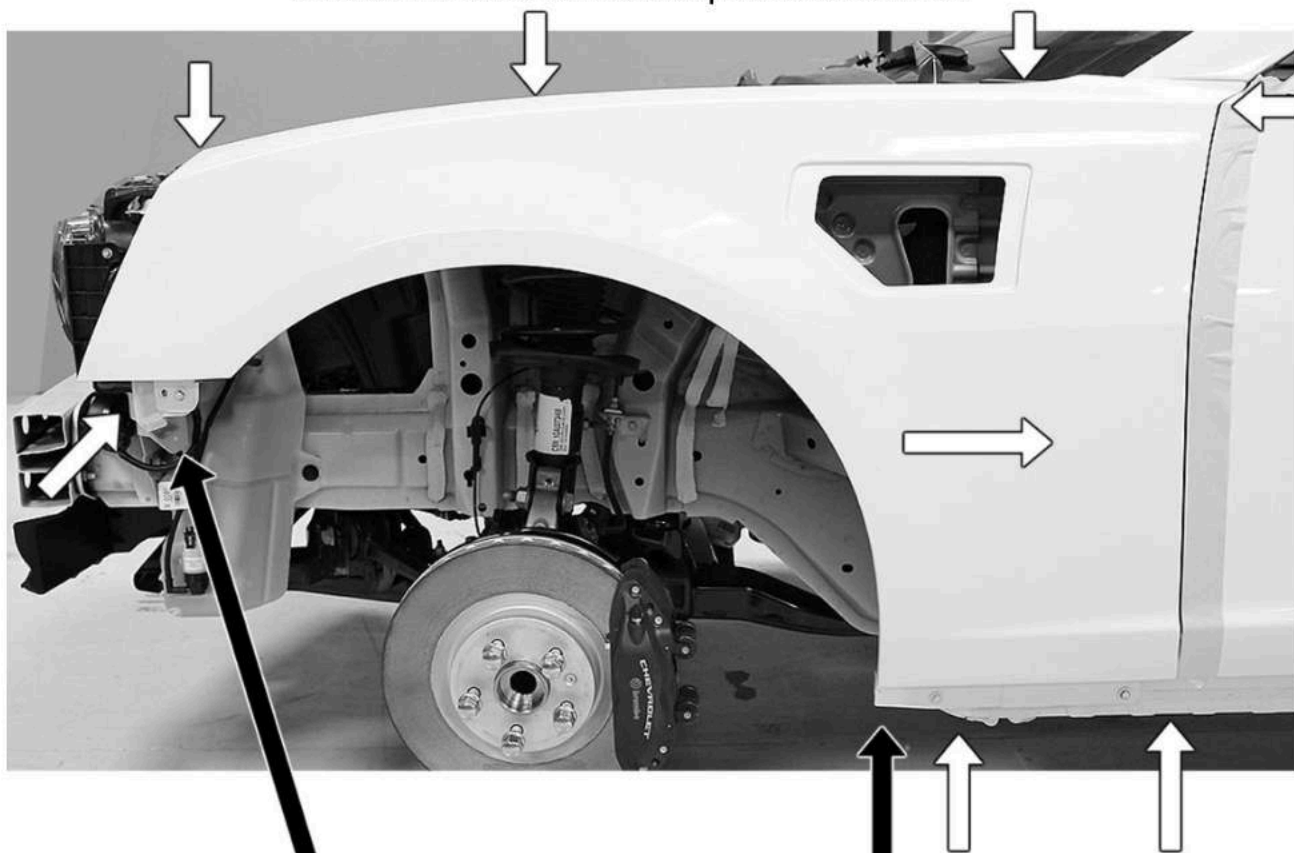

Remove screw clips from Camaro fenders and snap them into new fender. Needle nose pliers are recommended.

Make sure mounting flange is free from wax and rubbing compounds.



Apply 3M double sided tape (can be purchased in most auto supply stores). Once applied, peel back tape strips and center extractor in opening.



Press into fender firmly and around perimeter completely to ensure good tape adhesion



## Rocker Panel Installation

Start at the rear wheel opening. Snap in the top row of clips working forward.



After the top row has been engaged, reach under and push upward to engage the bottom row of clips.

Reinstall the front and rear T20 wheel liner screws.

# Front Bumper Cover Assembly

Place Front Bumper Cover on a table

Unplug daylight running lamp bulbs.

Unplug side marker lamps.

Unsnap and remove bumper absorber and wire harness assembly.

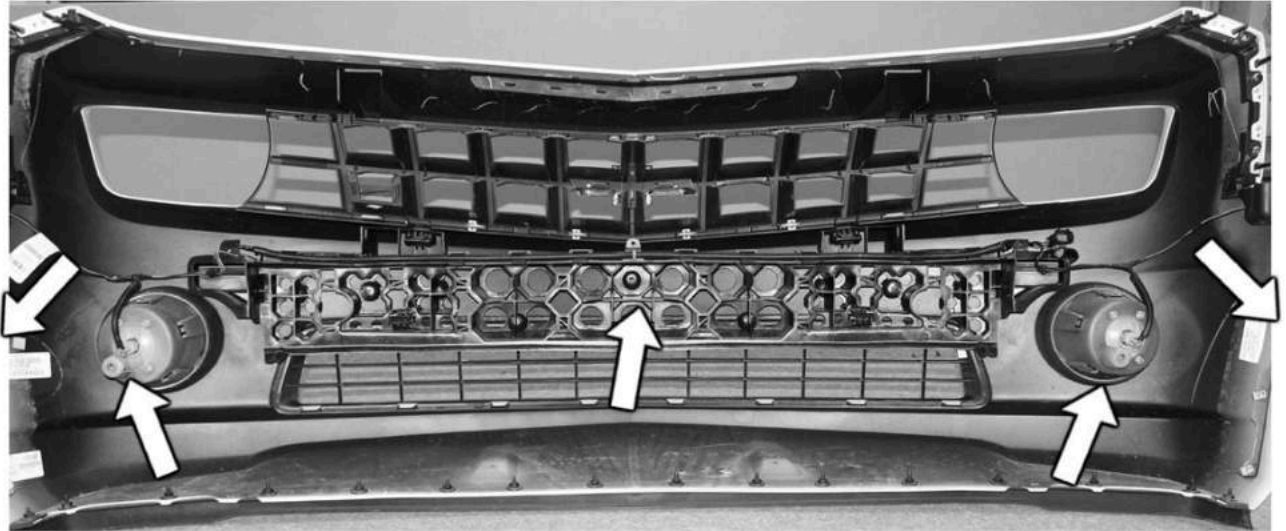

Remove daylight running lamps.

Remove side marker lamps.

Remove lower deflector.

Remove screw clips.

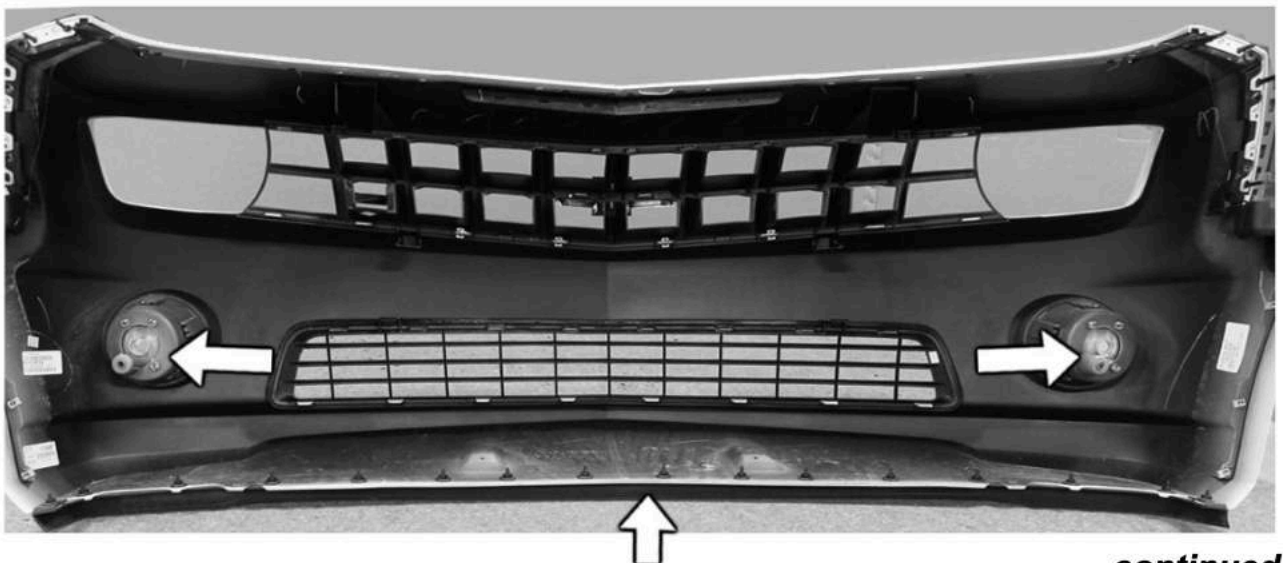

*continued*

Attach mounting brackets taken from the Camaro bumper cover to the ZTA front bumper cover. Use rivets as were attached previously

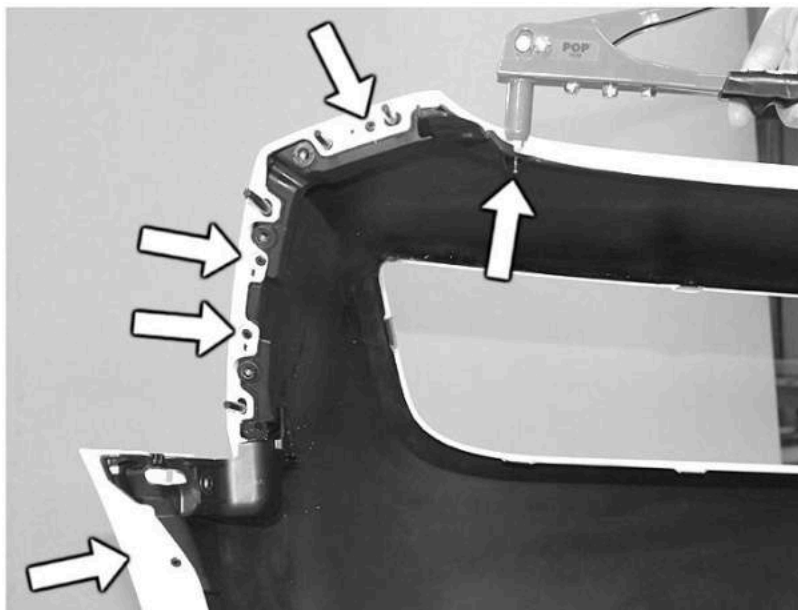

Make sure lower bracket is fully engaged.



Install lower grilles.  
Grilles are marked LH  
(driver) and RH (passenger).  
Install upper grilles.  
Install daylight running  
lamps/fog lamps.



Remove bezel  
from Camaro lamp.  
Snap into  
cover as shown.

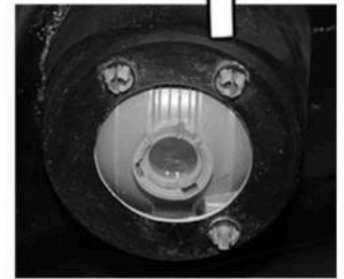

Snap grilles in completely.  
This requires significant  
force. Make sure every snap  
is fully engaged.

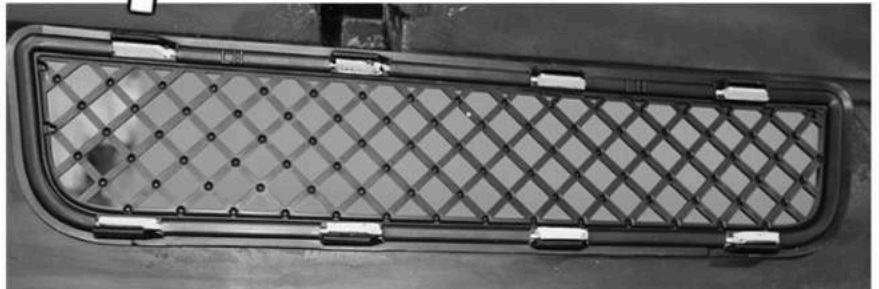

Reinstall the absorber and  
wire harness assembly.  
Plug in all bulbs.  
Insert screw clips into wheel  
liner flange. Reinstall lower  
deflector.



***continued***



# Front Bumper Cover Installation

Hold bumper cover to car by loosely attaching the two outboard M10 bolts.



Reinstall the inner fender attachments with 4 M10 bolts and 1 M7 screw.



Tighten the 2 M10 outboard bolts.

Reinstall the 2 bottom bolts.  
Reinstall the top push pin attachments.

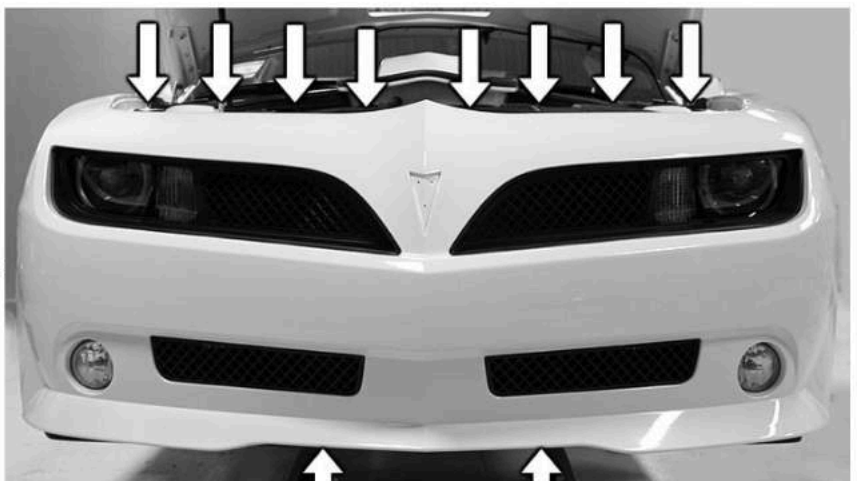

*continued*

Reconnect the main wire harness found on passenger side below head lamp.

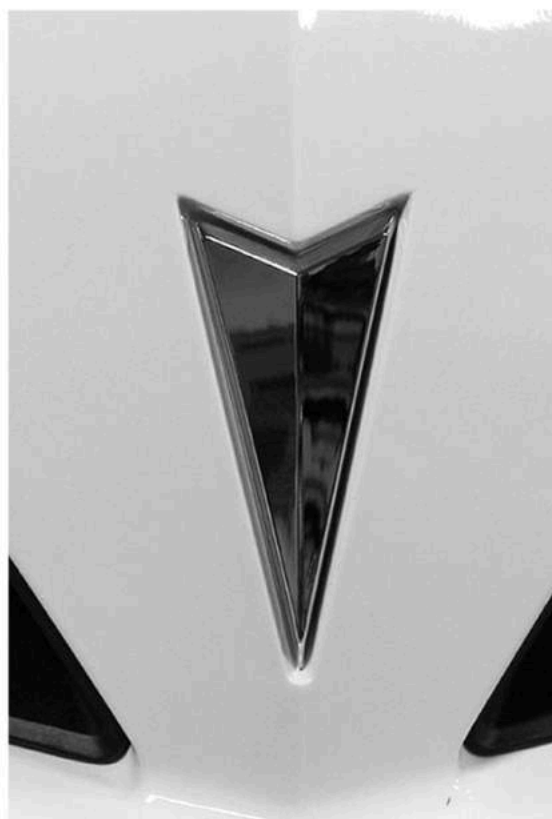
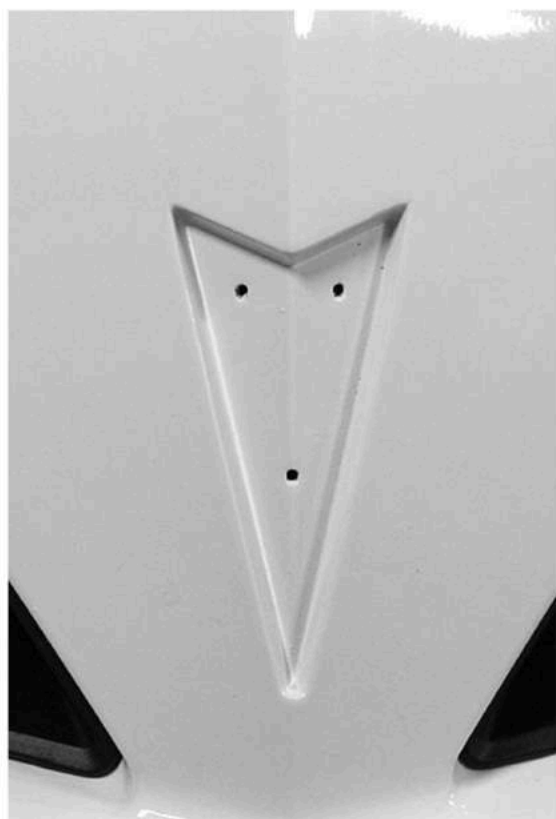
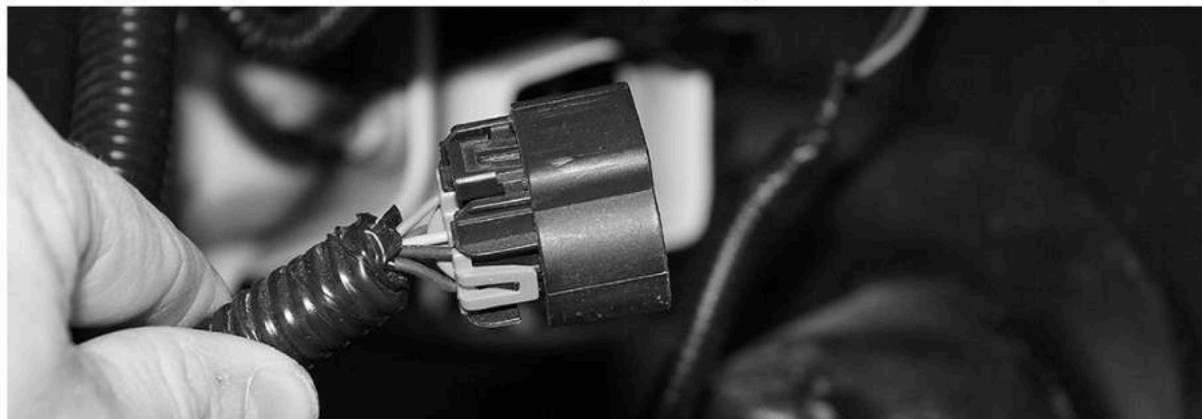

Make sure emblem area is clean and free from any wax or rubbing compound.  
Apply 3M double sided tape.  
Peel tape strips away. Line up locating pins and attach the front emblem.  
Press firmly all over to ensure good tape adhesion.

# Shaker Scoop Assembly

Remove engine cover.  
Place on a soft surface.  
Remove 4 star clips  
and insulator.



Using a 1/4", drill through the center of the 4 simulated bolt heads as shown.

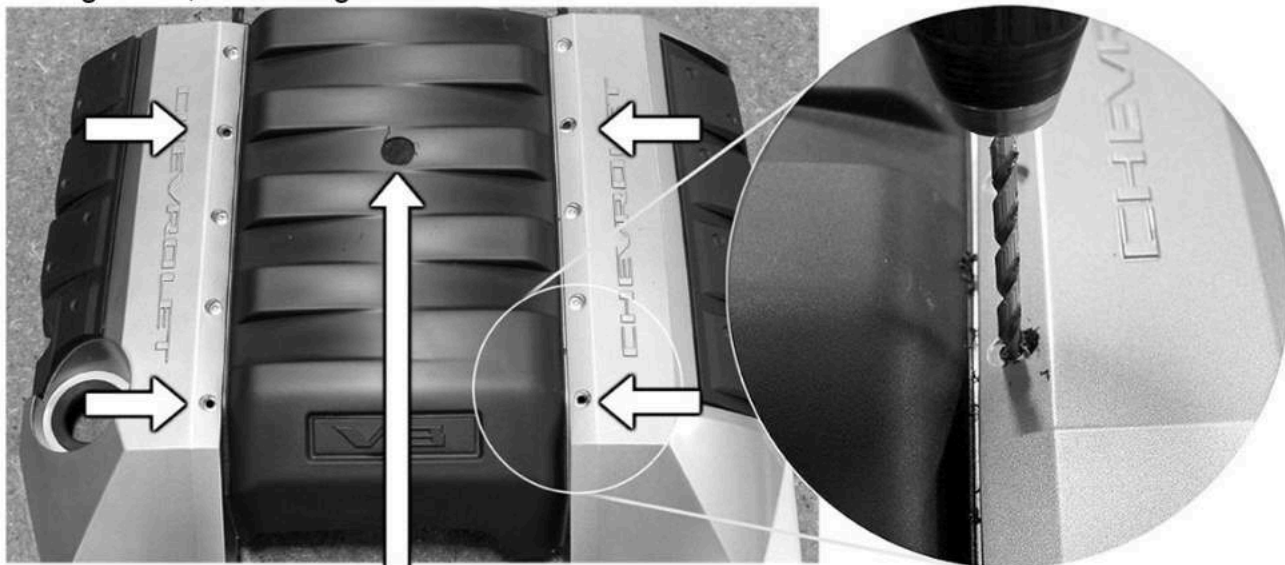

Drill 1/2" hole through center of 4th bar from rear edge.

Install 4 supplied 3/8" well nuts.

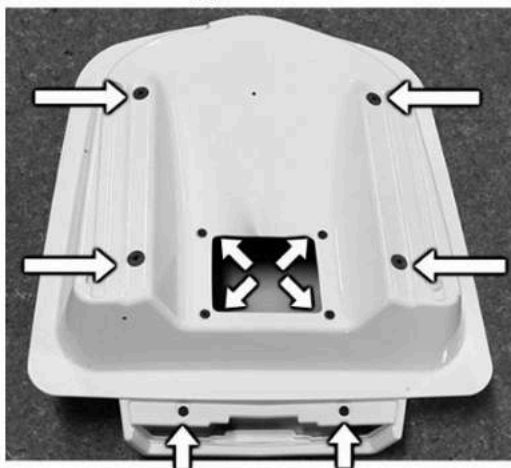

Install 6 3/16" well nuts



## Shaker Scoop Assembly *continued*

Carefully, load door assembly into solenoid, not letting the spring slip off.  
Load upside down as shown for best results.



Install door retaining bezel and attach with 2 supplied 8/32 - 1/2" screws.



Push on supplied vacuum hose to solenoid switch. Push on the barb.

Apply bulb seal to scoop flange as shown. Start at one side and work your way around. Making sure to follow parallel to edge.



Install hose barb nipple, and tighten with 3/4" socket. Snug tight, and do not over tighten.



Push on supplied drain hose.



# Hood Assembly (prior to mounting to car)

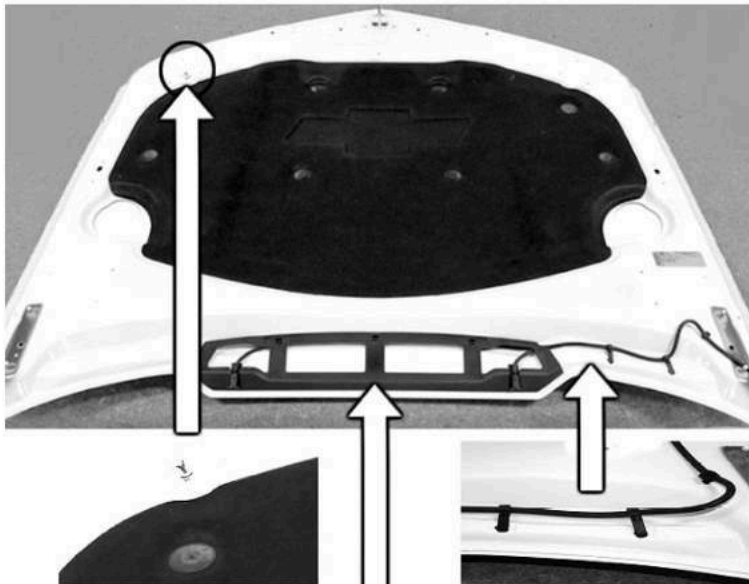

Lay Camaro hood on soft surface.

Remove prop rod ball stud.

Remove 3 hose clips.



Unsnap retaining bezel.



Unsnap washer nozzles from retaining bezel.

Reinstall hood prop rod ball stud.

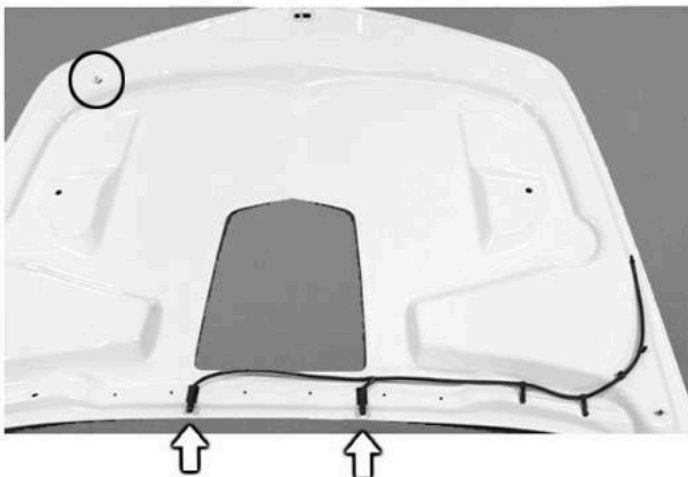

Reinstall both washer nozzles as shown.

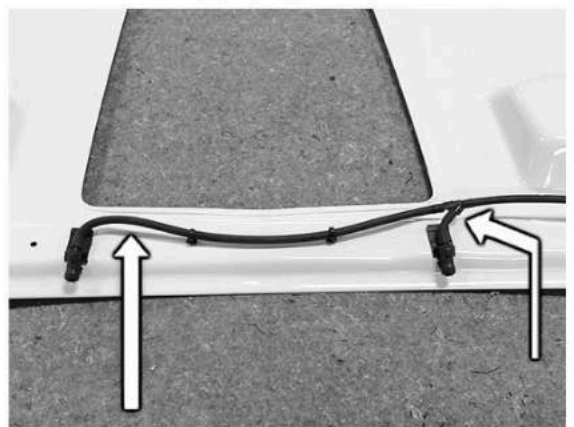

Shorten this hose by approximately 10 inches.

Shorten this small hose by approximately 1.5 inches



Install 4 M13 hinge nuts.  
Properly align hood and tighten.  
Reconnect the washer hoses.