



ENDURO ***SERIES***
FILTER
COMMERCIAL STRENGTH POLYMER MEDIA FILTER



OWNERS MANUAL

INTRODUCTION

Congratulations on choosing the Poolrite Enduro Series High Rate Media Filter fitted with the exclusive Poolrite V2000 valve. These systems incorporate the very latest technology in swimming pool media filtration.

These filter tanks are moulded from a very advanced "Engineering Polymer" which enables the Evolve Group to apply a 10 year Warranty to these filter tanks.

Poolrite's micro-slot underdrain system, featuring our exclusive folding lateral arm technology, combined with the use of a deep, dual-media Diamond Kleen bed, gives longer filter cycles and more efficient backwashing, resulting in less time being spent on maintaining your equipment and more time left to allow you to use and enjoy your pool.

The V2000 valve represents the culmination of several years of research and development at Poolrite to produce a filter control valve which provides far less noise and restriction to water flow, is easier to operate and requires no maintenance.

The V2000 valve also has an inbuilt Sight Glass to give you a positive indication when backwashing is complete, thus eliminating guesswork and reducing waste of pool water.

To ensure maximum performance, all systems should be fitted with a proven high performance Poolrite Pump featuring corrosion resistant design.

All equipment is weather resistant and constructed to protect your valuable investment.

Australian design and manufacture is your guarantee of after-sales backup.

CONTENTS

Introduction	1
How A High Rate Sand Filter Works	3
Delivery of Your High Rate Sand Filter	3
Attention Installer	4
Installation Instructions	5
Starting Up Procedure	7
Priming The Pump	
Starting The Filter	
Backwashing	8
Filter By-Pass / Waste	8
Recirculating	9
Valve Closed	9
Vacuum Cleaning	9
Trouble Shooting	10
Specifications	11
Warranty	13
Warranty Conditions	14

HOW A HIGH RATE MEDIA FILTER WORKS

The filter pump draws water from the pool and forces it under pressure into the multi-function V2000 Valve where it is directed into the top of the filter tank via an overdrain diffuser. The water then flows down through the media bed, into the underdrain and back to the pool.

The action of the water containing suspended particles passing through the filter bed causes the larger particles to be trapped and retained by the Diamond Kleen. Some of the very small particles may, however, pass completely through the filter and return to the pool, but in the process will have gained an electrostatic charge due to their high velocity over the media. This charge causes these particles to be attracted together to form clusters which are then large enough to be trapped by the Diamond Kleen on their next pass through the filter.

This is a normal characteristic of all high rate media filters.

As the quantity of suspended particles trapped in the media bed increases, the passage of water becomes progressively restricted, but this also results in an improvement in filtration fineness. However when this restriction to flow becomes excessive (as indicated by the rise in gauge pressure) the filter must be cleaned to restore a normal flow of water.

Cleaning is achieved by reversing the flow of water so it flows upwards through the media bed causing the individual grains of filter media to become buoyant and allow the bed to expand and release the trapped dirt particles which are then flushed out of the filter to the waste drain. This process is called BACKWASHING.

DELIVERY OF YOUR MEDIA FILTER

Each Poolrite filter/pump is delivered in two cartons as follows:

CARTON 1

Factory assembly filter includes:

- Lateral
- Tank
- Clamp bands
- Gasket
- Installation & Owners Manual with Warranty Card.

CARTON 2 (if ordered)

Factory assembly V2000 Valve includes:

- V2000 Multiport Valve
- Three 50 x 50mm take-off unions with 'O' Rings.
- Three 50 x 40mm reducing bushes.

ATTENTION INSTALLER

- 1) BOTTOM OF INTERNAL STANDPIPE MUST BE LOCATED ON SPIGOT AT BOTTOM OF TANK BEFORE ADDING MEDIA!!**
- 2) THIS MANUAL MUST BE GIVEN TO THE POOL OWNER FOR COMPLETION OF WARRANTY DETAILS!!**

OPERATIONAL CHECK POINTS

Failure to adhere to the following directions will void the Warranty!

1. Filter Pump should not be connected via extension leads as damage to motor can result.
2. At least 130mm clearance must be provided at fan cowl (rear) end of motor for efficient ventilation.
3. Should the filter system be housed in an enclosure, provision must be made for adequate ventilation.
4. Filter system must be installed in a position with effective drainage to guard against potential flooding in heavy rain or malfunctions in plumbing.
5. The pool water level must be at least half way up the skimmer box opening.
6. Make sure both skimmer box basket and pump basket are in place.
7. On initial vacuum cleaning of the pool, it is wise to use a filter sock in the pump strainer basket to prevent excess debris damaging the pump impeller seal.
8. Do not operate the filter system in FILTER mode unless the free chlorine level is between 0.5 and 3.0 ppm and the pH level is between 7.0 and 7.8 for concrete pools and 6.8 and 7.2 for other types of pools, or as recommended by the Pool Builder.
9. Do not vacuum clean the pool when the filter valve is in the BACKWASH position.
10. Do not operate the filter valve handle while the pump is running.

IMPORTANT

Read the following instructions carefully to ensure trouble free efficient operation of your filtration system for many years!

INSTALLATION INSTRUCTIONS

IMPORTANT

- Tighten all backnuts by hand only — DO NOT USE TOOLS!
- Pump/Filter should be installed between 1.0 metre above or 1.0 metre below mean pool water level for correct operation.

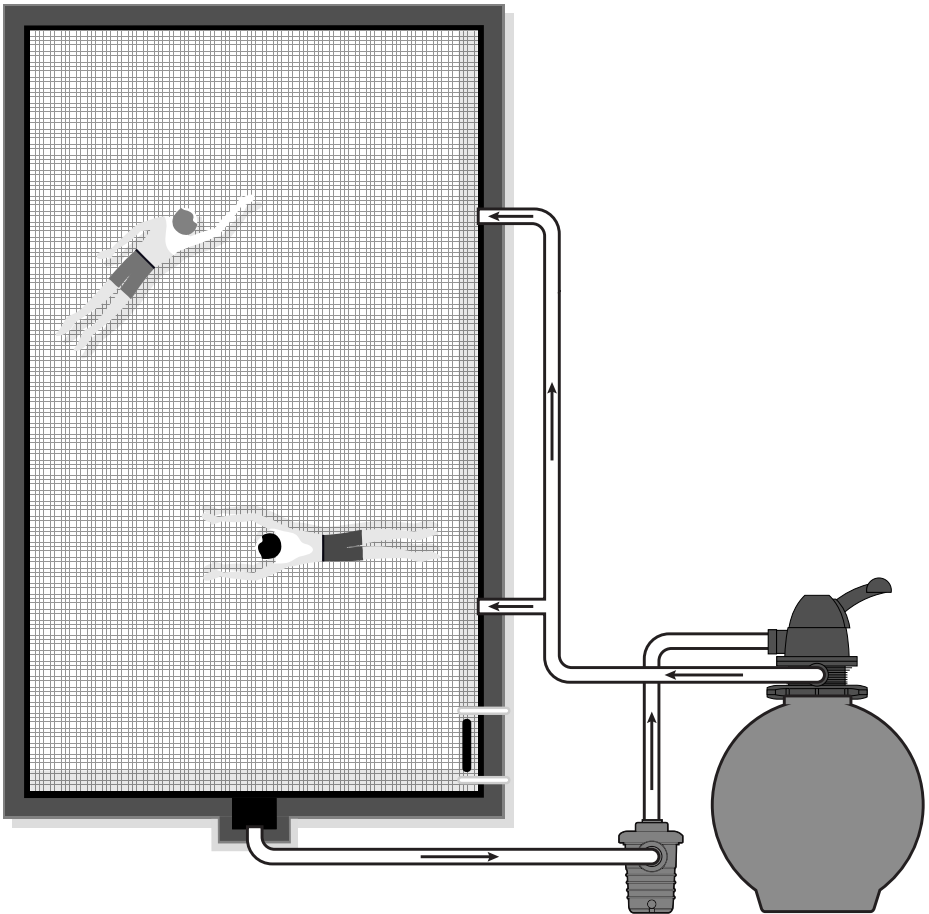

Connecting The Pump To Filter

1. Place filter tank on a level concrete slab having minimum dimensions as shown under SPECIFICATIONS (Page 11).
2. Position tank filter label to the front then place pump on the left side with suction port facing front. (For above-ground pools this may have to be rotated 180°).
3. Fit all of the moulded couplings to the V2000 Valve ports and the pump ports.
4. Using standard PVC pressure pipe and fittings, fabricate suitable connecting plumbing between the top pump discharge port and the PUMP port on the V2000 valve.
5. Make all remaining connections from the pool and waste plumbing to the pump and V2000 Valve.
6. Remove V2000 Valve after disconnecting PUMP, RETURN and WASTE plumbing and Split Clamp Band.
7. To ensure correct separation from internal standpipe assembly:
 - a) Lift the V2000 Valve approximately 250mm.
 - b) With other hand, reach under valve then twist and pull standpipe downwards until separated.
8. Place valve and rubber gasket in a clean place.
9. Re-position bottom of standpipe assembly in bottom of tank.
10. While holding standpipe central in the neck of the tank, gently push outer ends of all lateral arms down until they contact the tank wall.
11. Fit white moulded standpipe locator between top of standpipe and tank neck. Fit red plastic cap to top of standpipe (this will prevent media entering standpipe during filling).
12. Quarter fill tank with water. Add the correct amount of graded M20 Diamond Kleen (refer specifications) and distribute evenly across the bottom of the tank.
13. This should completely cover all parts of the underdrain assembly.
14. Add the correct amount of graded M10 Diamond Kleen (refer to specification), levelling the bed when needed.
15. Remove black moulded standpipe locator, then clean all media and dust from neck area of tank.
16. Replace, rubber gasket and multiport valve.
17. Refit and tighten Split Clamp Band.
18. Re-connect PUMP, RETURN and WASTE plumbing to V2000 Valve.

STARTING UP PROCEDURE

Priming The Pump

Priming the pump is required if the installation is above the pool water level. If the pump is installed below the water level isolating valves should be fitted then go to "Starting The Filter".

1. Remove clear pump lid, then fill pump bowl with water to the suction inlet level.
2. Check the rubber pump lid seal is clean and lightly lubricated with silicone-based grease and is correctly located in the groove.
3. Replace clear lid.

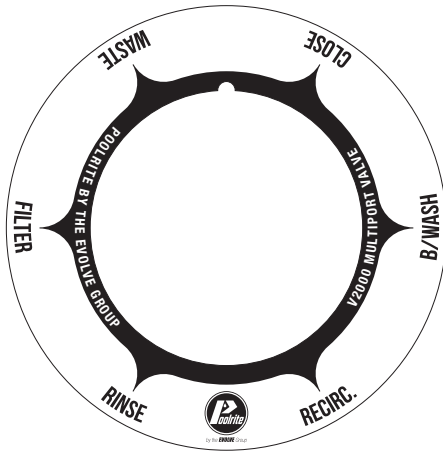

Starting The Filter (New Pools)

1. Set V2000 Valve to WASTE position.
2. Vacuum clean pool to waste to remove excess debris from pool and pipes (refer to VACUUM CLEANING section page 9).

(Existing Pools)

3. Set V2000 Valve to BACKWASH position.
4. Ensure all plumbing lines to and from the pool are clear (i.e. shut off valves are OPEN).
5. Switch the pump ON.

6. Observe reaction through clear pump lid: The pump will first draw water in surges until all the air within the pump bowl and suction piping has been expelled. If air is still present after approximately 3 minutes repeat "Priming The Pump" instructions, then if air is still present, check the following:
 - a) Pump lid correctly tightened onto seal.
 - b) "O" Rings fitted under unions.
 - c) Backnuts tightened fully (by hand only).
 - d) Plumbing joints (all glued)
 - e) Sufficient water in pool.
 - f) Skimmer weir is free and not jammed.
 - g) Strainer baskets not blocked.
 - h) All appropriate in-line valves open.
 - i) If air is still present the suction pipe to the skimmer should be checked.

7. After pump has fully primed, run for approximately three (3) minutes or until water in Sight Glass becomes clear.
8. Switch pump OFF.
9. Turn valve handle to RINSE position.
10. Switch pump ON and run until water in Sight Glass is again clear (approx. 20 seconds).
11. Switch pump OFF.

12. Turn valve handle to FILTER position.
13. Switch pump ON.
14. The filter system is now filtering the pool and the pressure gauge should be reading in the green FILTER range.
15. When the pressure gauge reading reaches the start of the red CLEAN band, the filter must be cleaned by BACKWASHING.

BACKWASHING

1. Switch pump OFF
2. Remove vacuum cleaner plate (if fitted) from skimmer.
3. Turn V2000 Valve handle to BACKWASH position.
4. Switch pump ON and run until water in Valve sight glass is completely clear.
5. Switch pump OFF.
6. Turn Valve handle to RINSE position.
7. Switch pump ON and run until water in Valve sight glass is completely clear (about 20 seconds).
8. Switch pump OFF.
9. Turn Valve handle to FILTER position.
10. Switch pump ON.
11. Reconnect automatic vacuum cleaner (if fitted) to skimmer.

The system is now filtering normally again and the pressure gauge should be reading in the lower portion of the green FILTER band.

IMPORTANT: Before and after backwashing, check that the pool water level is correct.

FILTER BY-PASS / WASTE

If the pool is often overfilled by rain and to return it to its normal level, proceed as follows:

1. Switch pump OFF.
2. Set V2000 Valve to WASTE position.
3. Switch pump ON. The excess water is discharged to waste.
4. When correct water level has been restored, switch pump OFF.
5. Set Valve to FILTER position.
6. Switch pump ON. The filter is now operating normally

A USEFUL HINT: When lowering the pool level with the V2000 Valve set in the WASTE position (only), vacuum cleaning may be performed at the same time, as under this condition the filter will not collect sludge and debris as it will all be discharged to WASTE.

RECIRCULATE

With V2000 Valve set in RECIRCULATE position the pool or spa water is recirculated via the pump without passing through the filter. This can be useful to provide extra flow for boosting spa jets or added circulation for heating.

VALVE CLOSED

The pump must always be switched OFF when V2000 Valve is in the CLOSED position. This setting is used to prevent the filter contents draining back through the pump when the lid is removed to enable cleaning of the strainer basket.

Ensure V2000 valve is in the FILTER position before restarting the pump.

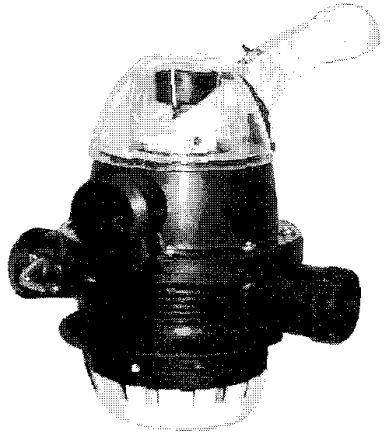

TROUBLE SHOOTING

Filter Pressure Build Up Rapidly

- Check eyeballs in pool are open.
- Check for algae in pool.
- Vacuum cleaning has been done with valve in backwash position.
- Ineffective backwashing due to poor water flow.
Check for restrictions from blocked strainer baskets or air leaks in pump or suction plumbing. Check that automatic pool cleaner has not been left connected to skimmer during backwashing.
- Check for algae inside filter.

Air Bubbles Back to Pool

- Check sufficient water flow.
- Check suction pipe connectors are tight.
- Check pump lid seal is clean, lubricated with silicone grease and correctly fitted and tightened.

Water Drains Back to Pool when Pump Switched Off

- Check pump lid for leaks.
- Check valve for leaks.
- Check backnuts are tight on all pipe connectors.

Pump Loses Suction

- Check strainer baskets in pump and skimmer box are not blocked with debris.

NOTE: After opening the pump strainer pot lid air will have entered the filtration system. Re-priming the pump may be necessary when the system is started again.
- Check filter condition from pressure gauge and backwash if necessary.

Algae/Milky Coloured Water

- Contact your pool builder or local pool shop for advice on chemical balancing the water, as damage to the filtration equipment or pool surface may result if not corrected.
-

SPECIFICATIONS

	E9000	E8000	E6000	E5000
SUITABLE POOLRITE PUMP MODELS	SQI700	SQI600 SQI500	SQI600 SQI500 SQI400	SQI400
Max. Flow Rate (L/min)	550	450	280	200
Fine Diamond Kleen Grade (mm)	M10	M10	M10	M10
Fine Diamond Kleen Weight (kg)	150	120	90	45
Coarse Diamond Kleen Grade (mm)	M20	M20	M20	M20
Coarse Diamond Kleen Weight (kg)	60	45	45	30

DIMENSIONS

E-5000

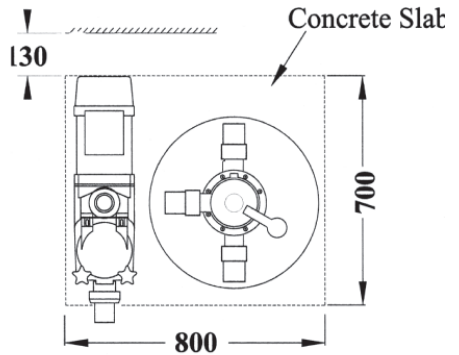
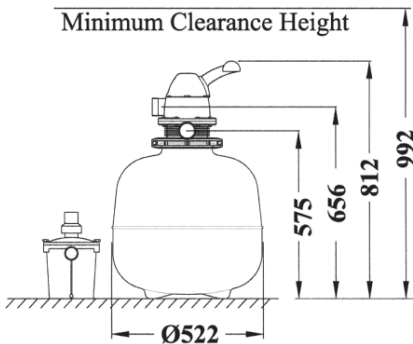

DIMENSIONS

E-6000

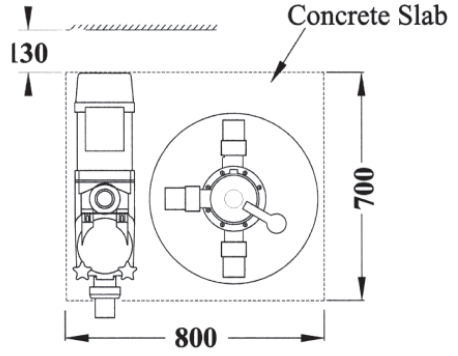
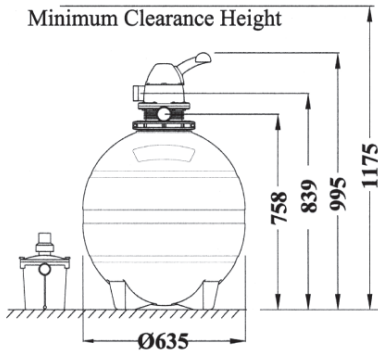

E-8000

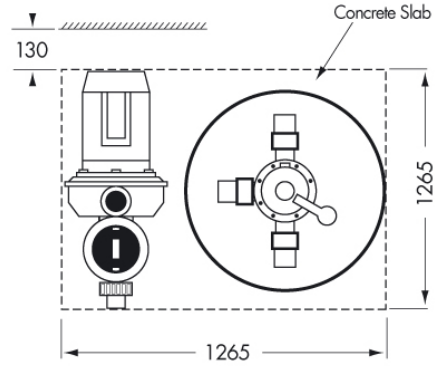
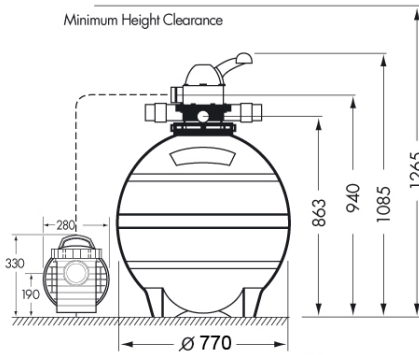

E-9000

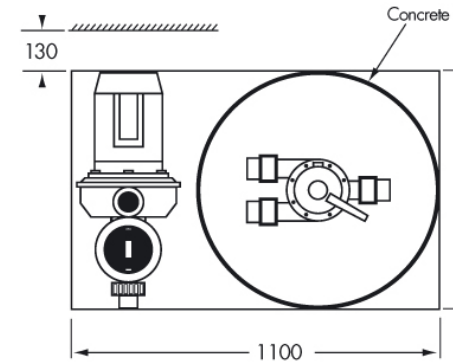
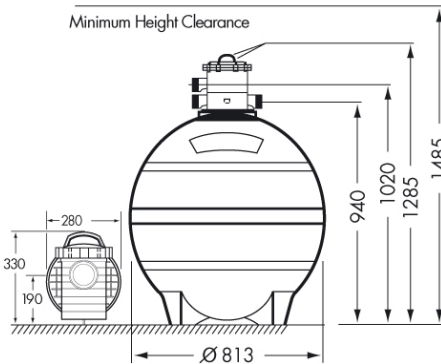



WARRANTY CARD

Name of Purchaser

.....

Address

.....

Purchased From

..... Date

Equipment and Model.....

IMPORTANT: This Warranty Card should be filled in and returned to:

Marco Engineering Pty. Ltd.

PO Box 1491, Browns Plains QLD 4118 Australia

KEEP WITH PROOF OF PURCHASE

WARRANTY CONDITIONS

Marco Engineering Pty. Ltd. ABN 48 165 399 637

POOLRITE FILTRATION SYSTEMS

Your POOLRITE Filtration Equipment is manufactured to the highest possible standards and most up-to-date technology. Accordingly the equipment carries the following Warranty, should a fault occur due to faulty manufacture or materials.

IMPORTANT

In the event of a fault covered by Warranty occurring, the Purchaser must, in the first instance, contact Marco Engineering or the nearest authorised Poolrite Distributor.

E5000 / E6000 / E8000 / E9000

1. All components in the Filtration System, with the exception of the Filter Tank, carry a one year (12 months) Warranty from the Date of Purchase by the Original Owner.
2. Due to Marco Engineering's Advanced Moulding Technology, the Filter Tank (the most important part of your Filtration System) carries a special Extended Warranty of ten years from the Date of Purchase by the Original Owner. The terms of this Warranty cover full replacement, excluding the cost of labour, of a defective Filter Tank for the Original Owner for a period of 10 years.
3. No claim in pursuance of this Warranty will be recognised unless received by Marco Engineering during Warranty period.
4. The "Filter Tank" is defined as the Filter Housing Moulding only, without any attachments such as Valves, Internal Fittings or Plumbing, etc.
5. The Warranty is void if the following are not adhered to:
 - The equipment must be installed and used in accordance with the instructions supplied.
 - The Equipment is designed to be used with swimming pool or spa pool water, chemically balanced in accordance with the Langelier Saturation Index with a pH of 6.8 to 8.0 that is regularly treated with a sanitising system utilising chlorine either added in compound form or generated in situ in concentrations as recommended by the relative State Health Departments. Should other chemical treatment systems or parameters be used, Marco Engineering will not be responsible for damage done by corrosion, scaling and stress cracking of the equipment or the shortened filter cycles resulting
 - If, in the opinion of Marco Engineering, the equipment has been subjected to other than normal swimming pool or spa pool use or has been improperly serviced or maintained.
6. This Warranty is applicable to workmanship and materials only. Marco Engineering will replace, at no charge, all parts returned freight paid, which display faulty workmanship or materials. Marco Engineering Pty. Ltd. accepts no responsibility for loss, damage or injury to person or property arising from Warranty failure of equipment, or installation of that equipment, unless with the express authority of Marco Engineering or its Authorised Distributors and this Warranty shall not extend to any expenditure otherwise incurred.

PROOF OF PURCHASE SUPPLIED



P 07 3803 6222 | F 07 3803 6353 | E poolrite@evolvegrp.com

PO Box 1491, Browns Plains, QLD 4118, AUSTRALIA

www.poolrite.com

