

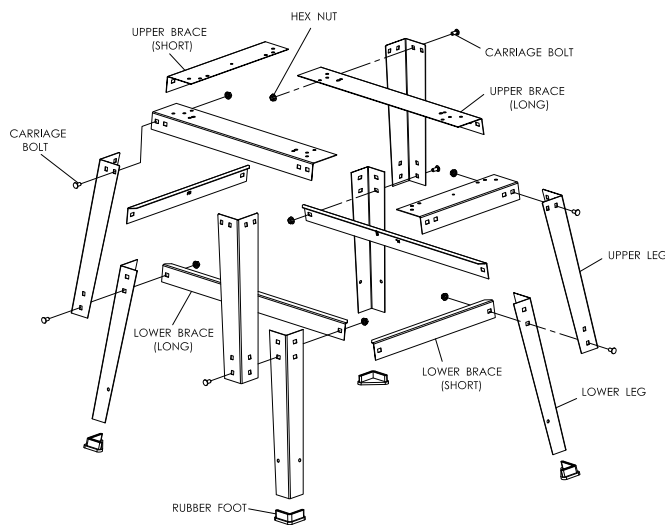

CUTECH



80200-CT UNIVERSAL STAND



DESCRIPTION		QTY
A	Upper Leg	4
B	Lower Leg	4
C	Upper Brace (Short)	2
D	Upper Brace (Long)	2
E	Lower Brace (Short)	2
F	Lower Brace (Long)	2
	Rubber Foot	4
	Carriage Bolt, M8x1.25-16	32
	Carriage Nut, M8x1.25	32

- Place upper brace (long) on the upper leg piece.

NOTE: Upper brace (long) has five holes on each end. These holes should be on top when leg stand is completely assembled.

- Align holes on the upper brace with the holes on the leg piece. Insert two carriage bolts and hand tighten using hex nuts.
- Place lower leg piece on upper leg brace from the inside. Place lower brace (long) on both the leg pieces from the inside.
- Align holes on all three pieces. Insert two carriage bolts and hand tighten using hex nuts.
- Attach another upper leg piece to the outside of upper brace (long) using two carriage bolts and hex nuts.
- Next, attach lower leg piece to the inside of upper leg piece and then place lower brace (long) on top of both the leg pieces (lower brace at the innermost layer). Insert two carriage bolts and hand tighten using hex nuts.
- Repeat the above steps to complete two of the four sides of the leg stand.
- Place upper brace (short) inside upper leg piece.

NOTE: Upper brace (short) has three holes on each end; these holes should be on top when leg stand is completely assembled.

- Align holes on upper brace (short) with the holes on the upper leg piece. Insert two carriage bolts and hand tighten using hex nuts.
- Repeat the above step on the opposite side.
- From the inside of the leg stand, place a lower brace (short) on both the upper and the lower leg pieces. Insert two carriage bolts and hand tighten using hex nuts.
- Repeat the four steps above on the opposite side.
- Wear rubber feet on the bottoms of each lower leg piece.
- Tighten all hex nuts with a wrench. This completes the leg stand.



WARNING! TO AVOID serious injury, death, or damage to the machine,
DO NOT mount any machine on the stand until the stand is completely assembled.
DO NOT run the machine until it is mounted on the stand securely.

- Mount your machine on the stand. Line up with the corresponding pre-bored holes (as shown below) at the four corners of the stand. Fasten the machine onto the stand with nuts, bolts and washers.

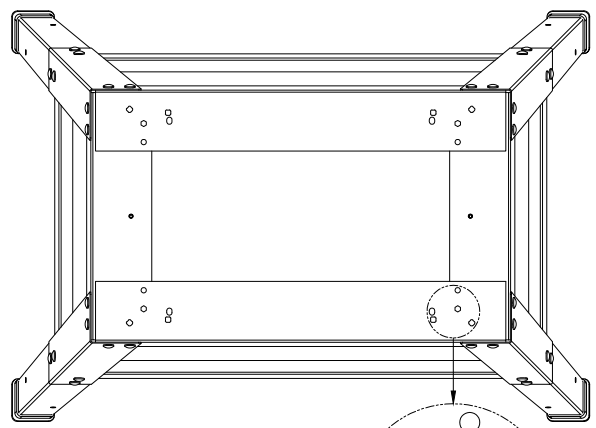
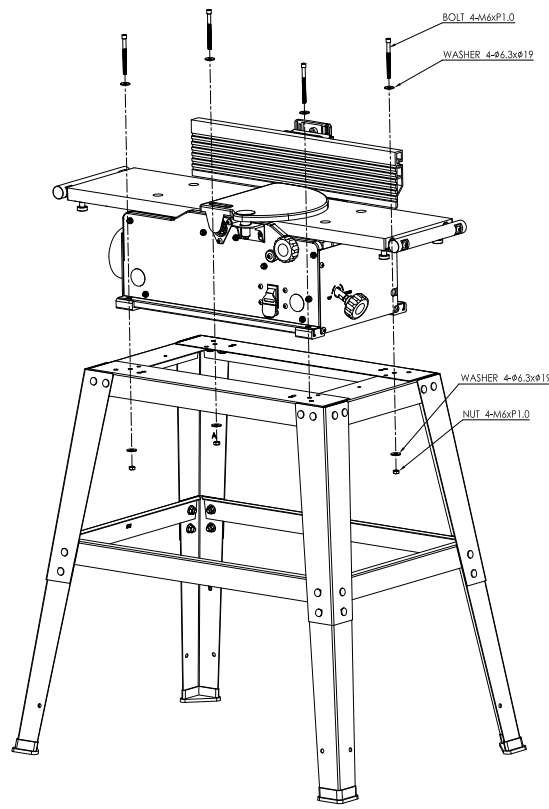

- PC305TP & 40100/40100H
- PC160JT & 40160H/40160HC
- 40180H/40180HC
- ◇ 40600H & 40200H/40200HC
- 40300H & 40700/40700H/40700HC

For technical support, email support@cutechtools.us or call 858-886-7333