



L-500/L-600

MECHANICAL INSTALLATION GUIDE

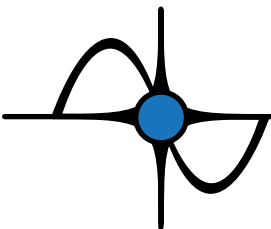
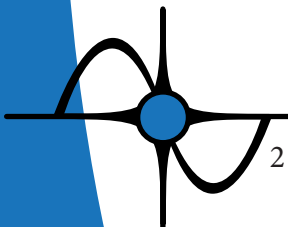

TABLE OF CONTENTS

TOPIC	PAGE(S)
TABLE OF CONTENTS	2
SYSTEM DIAGRAMS	3-5
INTRODUCTION	6
RANGE OF MOTION	7
UNPACKING	8-13
PREPARING FOR INSTALLATION	14-17
MOUNTING DRIVE-BASE TO PIER	18
HARD-STOP POSITIONING	19
INSTALLING EQ WEDGE	20
ATTACHING DRIVE-BASE TO EQ WEDGE	21
INSTALLING FORK-ARM	22-23
MOUNTING THE SADDLE	24
PREPARING THE OTA	25
PREPARING SADDLE FOR OTA	26
POSITIONING THE OTA	27
SECURING THE OTA	28
INSTALLING OPTIONAL 2ND SADDLE	29
BALANCING ALTITUDE/DEC	30-31
BALANCING AZIMUTH	32-33
BALANCING RA	34-35
POWER/COM CABLING FOR THE MOUNT	36
CABLE ROUTING FOR ACCESSORIES & INSTRUMENTS	37
DIRECT DRIVE AUTOTUNER (PWI4 SOFTWARE)	38-43



SYSTEM DIAGRAMS 1

SIDE-VIEW (OUTSIDE OF FORK-ARM)

ALT/DEC LOCKING KNOB,
REMOVE COMPLETELY
WHEN NOT IN USE, REPLACE
WITH SCREW PLUG (PROVIDED)

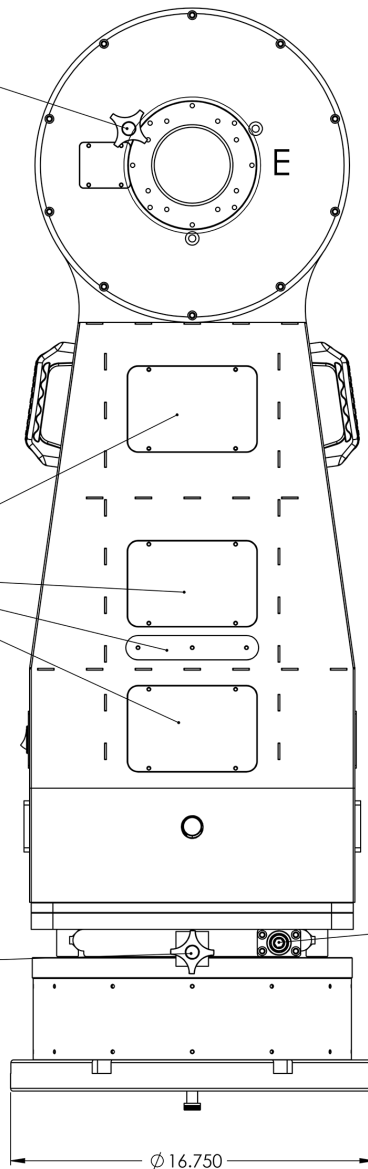

E

USER WIRE ACCESS COVER

AZ/RA LOCKING KNOB,
REMOVE COMPLETELY
WHEN NOT IN USE

BALANCING SCREW, REQUIRES
3/8" SOCKET (PROVIDED)

$\phi 16.750$

SYSTEM DIAGRAMS 2

SIDE-VIEW (INSIDE OF FORK-ARM)

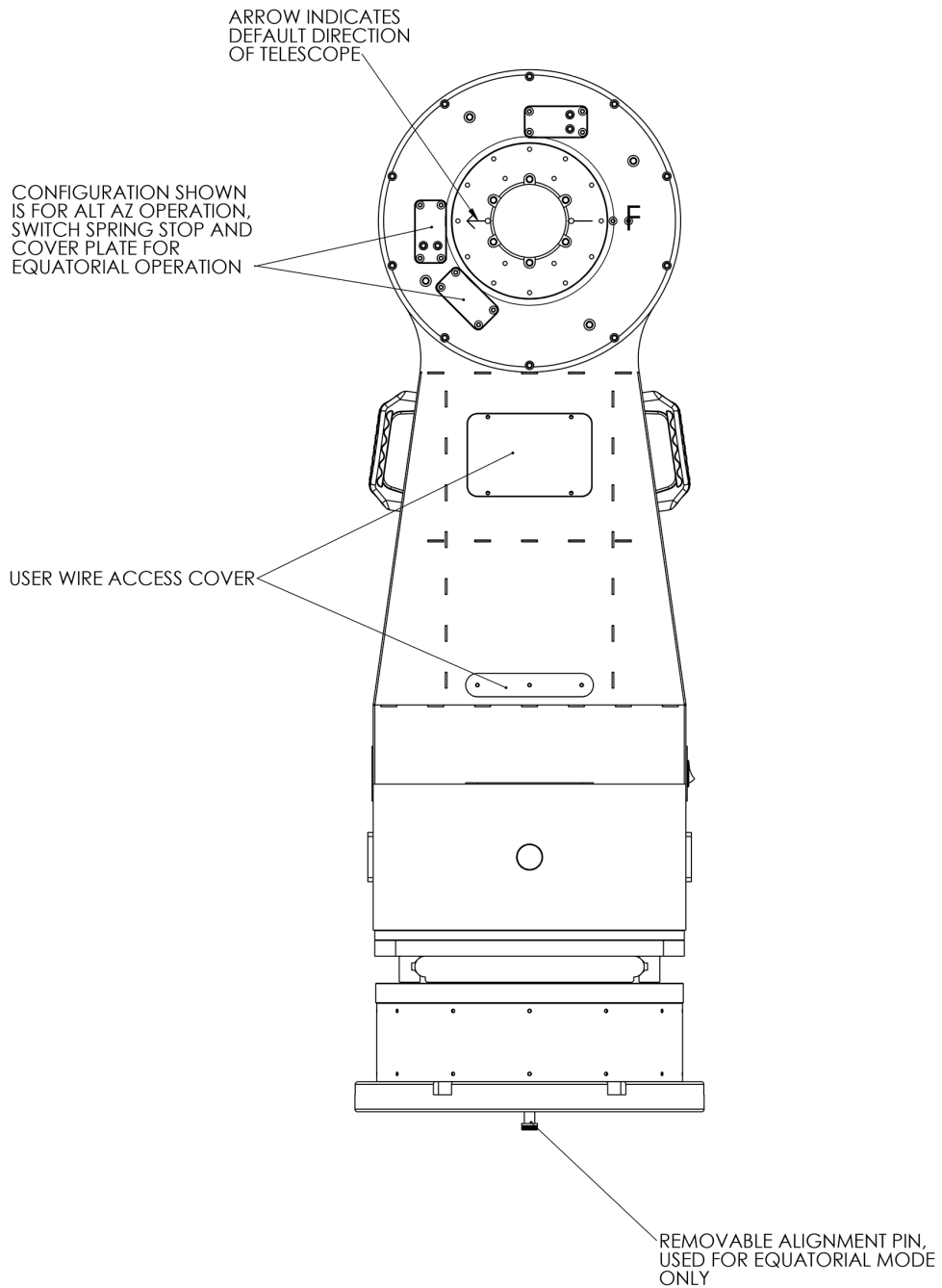

SYSTEM DIAGRAMS 3

REAR, DETAIL, AND OVERHEAD VIEWS

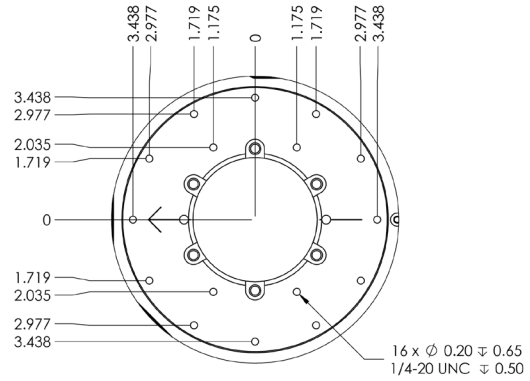
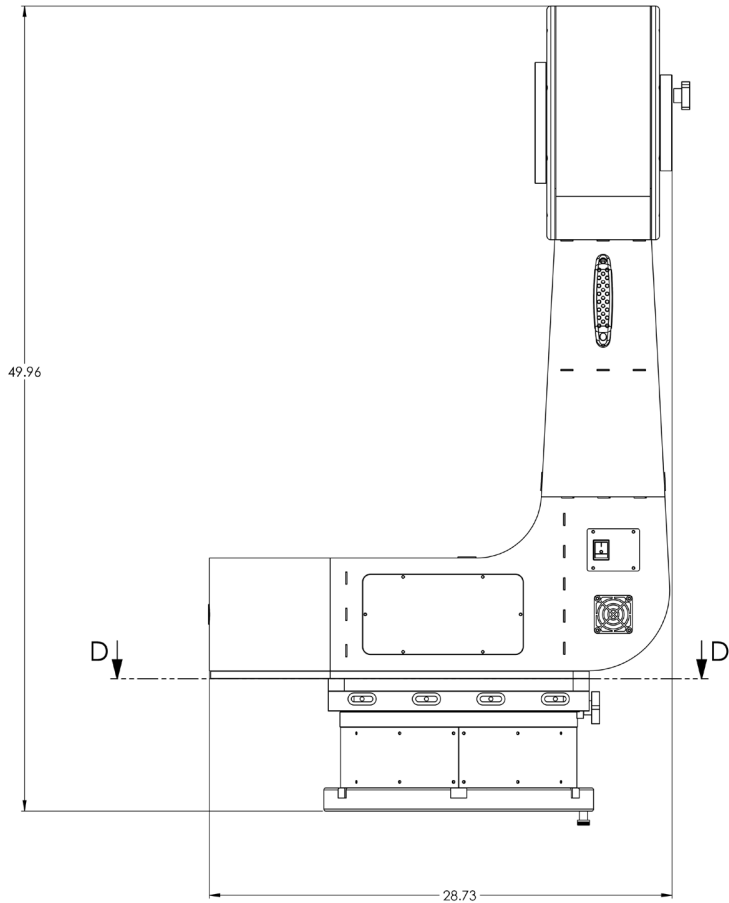

DETAIL F
INNER SCOPE
MOUNTING HOLES

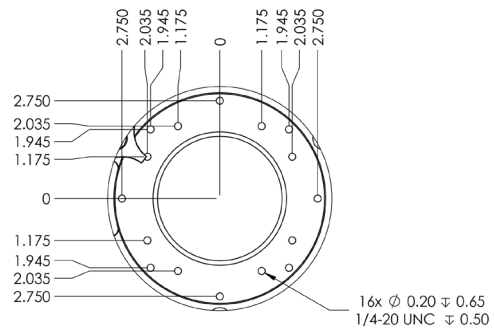

DETAIL E
OUTER SCOPE
MOUNTING HOLES

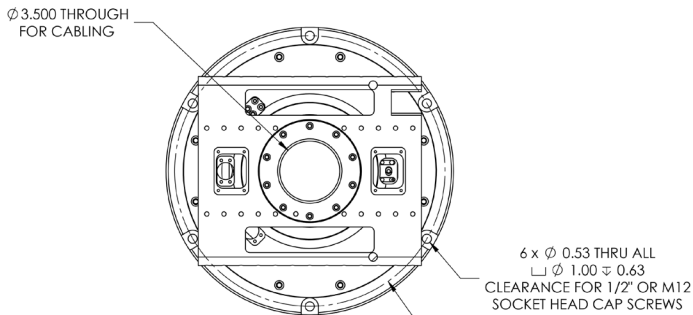

SECTION D-D
BASE MOUNTING
DIMENSIONS

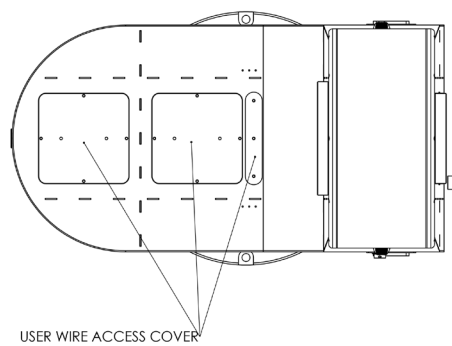

INTRODUCTION

Direct-drive motion systems offer a number of advantages over the more traditional systems used in astronomy:

1) Direct-drive systems do not use gears:

Traditional, gear-based motion systems can only move as precisely as their gears are cut. Surface imperfections in gears inevitably result in periodic tracking-errors.

Gears require lubrication, and consequently require routine cleaning and relubrication. This is exacerbated in dusty environments, where lubrication rapidly contaminates.

2) Without gears, there is no PE:

Direct-drive systems are effectively free of periodic error.

To be completely accurate, there is a small amount of periodic error in the motion of each of the individual bearings in the system. However, due the number of bearings in each assembly, there is negligible effect to motion of the total system. Additionally, each axis is equipped with high-resolution encoders reading at 8Mhz, that are more than capable of detecting miniscule deviations from the proper tracking-rate.

3) Lower hysteresis:

Mechanical hysteresis (the difference between where something was, when measured, and where it is now) is greatly reduced in a system that does not use gears. Remember all of that advice about how to properly balance by being out of balance, to keep gears engaged? None of that applies to direct-drive, and tracking is equally good on both sides of the meridian.

Total hysteresis of the L-Series mount is further reduced by the use of high-resolution encoders (18.8M counts/axis, 0.069 arc-second/count). These on-axis encoders allow the control-electronics to know precisely where the mount is pointed, more than 100 times per second. No auto-guider provides that volume of feedback.

4) Faster response:

Not only are the L-Series drives capable of far greater rates of speed, their response-times are also much faster. Consider all of the sources of backlash in a traditional system (planetary-gears, elasticity in belts, and the worm/worm-gear interface itself), and know they are not present with direct-drive. As soon as an L-series motor moves, your telescope moves.

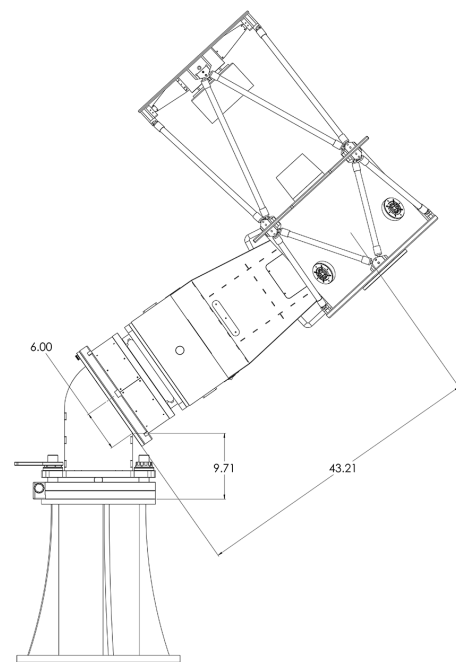

RANGE OF MOTION

L-Series mounts offer +/- 350 degrees of rotation in the Azimuth/RA axis, measured from the "No Wrap" position. The proper "No Wrap" position is found by aligning the related marks on the drive-base section of the mount (due the +/- 350 degree motion, these marks only line up at the correct position).

The Altitude/DEC axis has a fixed limit at the zenith (Alt-Az) or pole (EQ). The lower limit is adjustable, by moving the hard-stop between two positions:

- EQ position: In this configuration, the DEC axis is able to move 135 degrees below the pole, or 45 degrees below the celestial equator.
- Alt-Az position: In this configuration, the Altitude axis is able to move 85 degrees below zenith.

The position of the hard-stops for the Altitude/DEC axis can be changed, following the guidance offered in "Mounting (Alt-Az specific concerns)" chapter of this manual. There is also some discussion of why you may or may not want to use the EQ position when configuring the mount in Alt-Az.

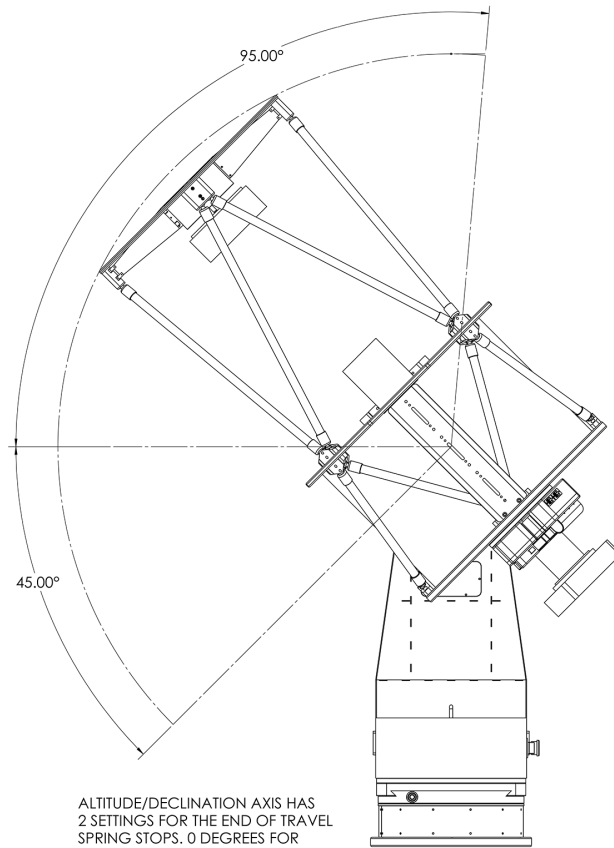

ALTITUDE/DECLINATION AXIS HAS 2 SETTINGS FOR THE END OF TRAVEL SPRING STOPS. 0 DEGREES FOR ALT/AZ CONFIGURATION AND -45 DEGREES FOR EQUATORIAL UPPER LIMIT IS FIXED AT 95 DEGREES

UNPACKING

Safely unpacking your L-series mount will require at least 2 people capable of comfortably lifting 60 pounds or more. For L-600 mounts, 3 or more people are recommended. It is recommended that your pier (and optional wedge, if to be used) are installed prior to unpacking the mount.

IMPORTANT NOTE:

Be sure to check the location of the fork's balancing adjustment screw interface (pictured below) relative to the fork-arm. In all L-500s and L-600s Serial-Number 1-15, this will be on the fork-side of the base-motor. In L-600s Serial-Number 16 and higher, this interface will be on the side of the base-motor opposite from the fork-arm.



When using a crane/fork-lift:

- All steps relating to disassembly of the mount should be skipped. The L-series mounts are capable of being lifted while fully-assembled (refer to "lifting points" section of this manual, below).

- Proceed to the "Remove the Drive-Base" segment of this section, below, and uncouple the mount from the crate. The mount will then be ready for lifting.

Required tools/supplies:

- Drill/driver, for removal of crate's wood-screws
- SAE Hex-Key Set

Opening the crate:

- Begin by finding the "front" panel of the crate, which will be marked, by removing the wood-screws attaching it to the bottom, top, and side panels.
- Remove the front-panel.
- Next, remove the woodscrews that attach the remaining 3 wall-panels to the bottom.
- Finally, slide the side/top panels (still assembled) off of the bottom of the crate.

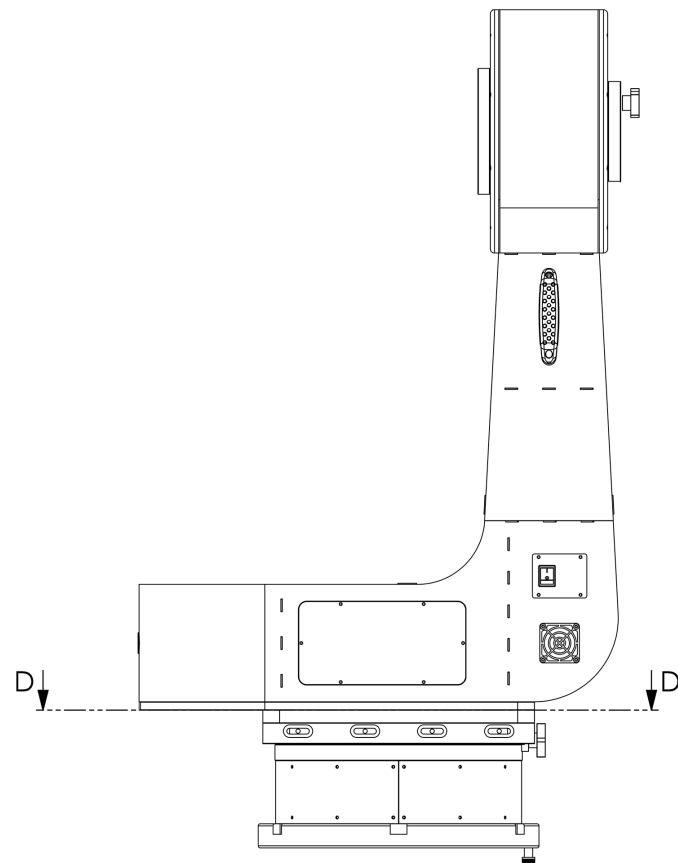

Removing the fork-arm:

To simplify packaging, your mount has been shipped with the drive-base and fork attached. While it is possible to lift the system in this assembled state with a fork-lift or crane, we highly recommend that the two assemblies are separated if people are lifting. Doing so allows unpacking and installation/reassembly to be done safely with the minimum number of helpers.

1) Begin by removing the bolts that hold the fork-arm to the drive-base, using a 1/4" Hex-Key. All of the fasteners needing removal are near the D/D intersection, shown in the drawing on the preceding page. The bolts on the exterior of the mount connect the azimuth saddle to the black-anodized plate on the bottom of the fork-arm.

- There are 14 bolt-holes around the perimeter of the bottom of the black-anodized saddle. (top 3 images, right)

2) Remove the access-panels on the top of the lower section of the fork-arm, and inspect the underlying mounting bolts on the bottom of the exposed cavity.

- There is set of 8 slotted bolt-holes in the interior of the mount. (six are fully shown in the bottom image, right)

- The two bolts closest to the fork-arm tine need to be removed. Set them aside for replacement when the fork-arm is reattached to the drive-base during installation. The other 6 bolts may be left installed.

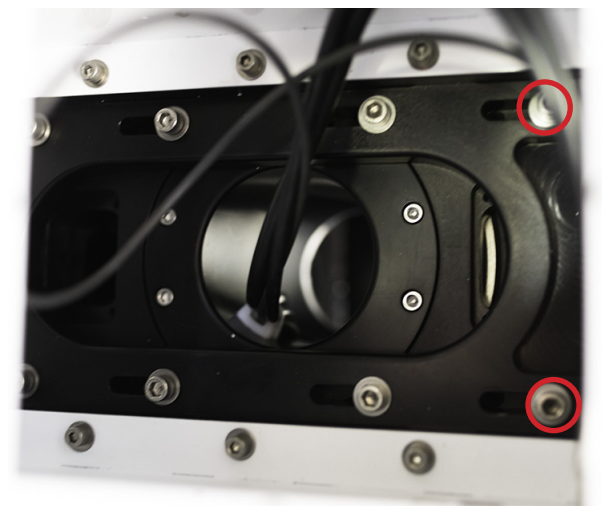
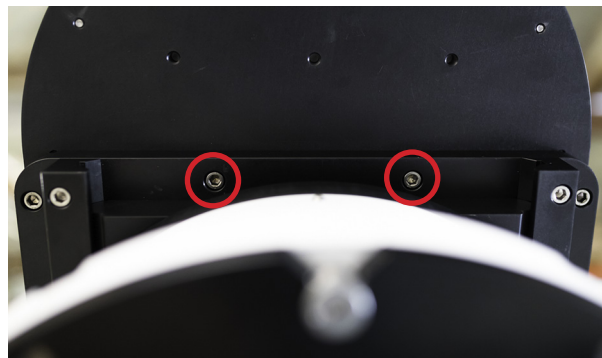

3) Remove the side access-panels on the lower-section of the fork-arm (drawing, below). At the bottom of each exposed cavity, you will see a shoulder-bolt that is still preventing the fork-arm from being lifted from the drive-base (top image, right). These bolts should not need be removed or loosened, the panel has been removed so that you can observe this interface.

4) Next, make sure that the wiring between the Azimuth / Right Ascension motor and main electronics board is disconnected from the drive-base (middle image, right).

5) Now tuck the cables safely out of the way, and into the pass-through in the drive-base (as shown in the bottom image, right).

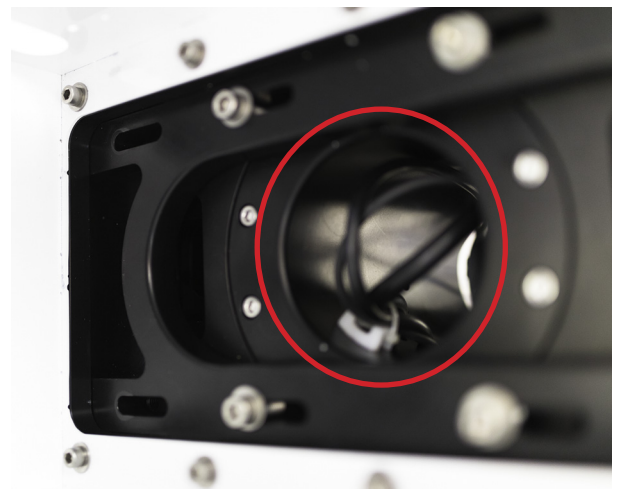
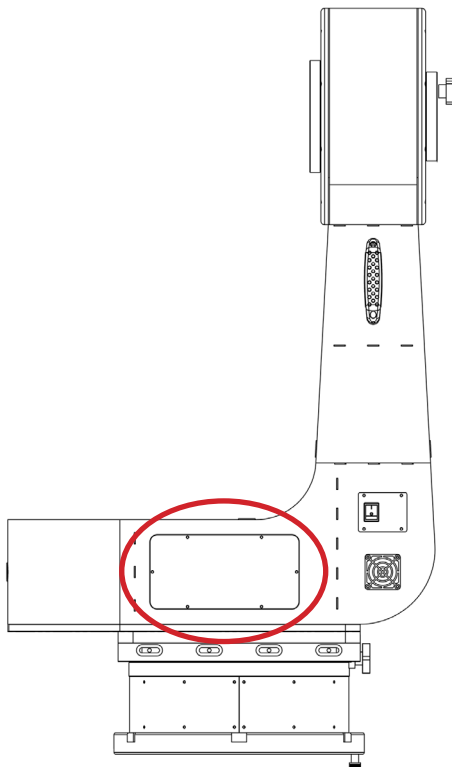
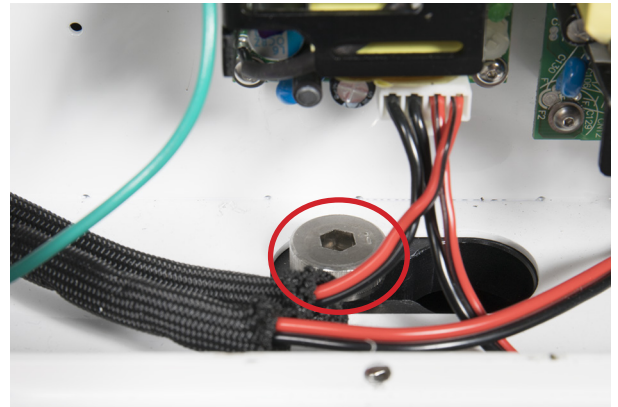

6) Before lifting the fork-arm, it is recommended that you place something on the ground, nearby, onto which the fork can be set without being scratched. This could be a tarp, old blanket, sheet of cardboard, or even the front-panel of your crate.

7) See “lifting points” under the Installation chapter.

8) Slide the fork-arm laterally so that the larger-diameter portion of the slots are beneath the shoulder-bolts. The fork-arm is now ready to be lifted from the drive-base.

9) With help from at least one additional person, lift the fork-arm away from the drive-base and set it on the surface you just prepared. You should allow the long-side of the “L” to rest on the ground, as it is otherwise possible for the fork-arm to tip over.



Removing the Drive-Base:

1) Remove the 6 bolts from the lower perimeter of the drive-base, which are currently securing the drive-base to the bottom of the crate (top image, right).

2) Verify installation and proper tightening of the Azimuth/RA axis locking-knob (shown in System Diagram 1, at the beginning of the manual). Not doing so will allow the lifting surface (black-anodized mounting plate for the fork-arm) to rotate, and may make it difficult to lift and maneuver the drive-base (bottom image, right).

3) Ensure that the cables which connect the drive-base electronics/motor to the main electronics in the fork-arm are safely-positioned, and not at risk of being snagged or sheared.

4) The drive-base is now ready for removal from the crate's mounting-plate. However, there is no need to lift it until the pier or optional wedge are ready to receive the drive-base.

Dovetails / other accessories:

The dovetail saddle and other accessories may be packed within boxes mounted to the floor of the crate. Be sure to open any boxes and inventory the contents.



Unpacking the optional EQ Wedge:

The optional equatorial wedge is fully assembled for shipment. Unpack and separate the sub-assemblies and move them near your pier.

The EQ wedge weighs approximately 145 pounds. While it may be possible for it to be moved while fully assembled, the unit will need to be disassembled to be installed.

The wedge is comprised of three major sub-assemblies: the angled wedge section, the upper mounting plate (attaches the wedge to lower mounting plate), and the lower mounting plate (attaches upper mounting plate to pier)

1) Remove the altitude-adjustment bolts on the north and south side of the wedge, and remove the wedge section.

2) Remove the bolts that secure the un-anodized rotation-hub (located around the center of the upper mounting plate), and remove the hub from the center-holes of the two plates.

3) Remove the six bolts that join the perimeter of the upper and lower mounting plates, and remove the upper mounting plate.

Installation will be addressed below, and should be completed prior to re-assembling the mount after its unpacking.

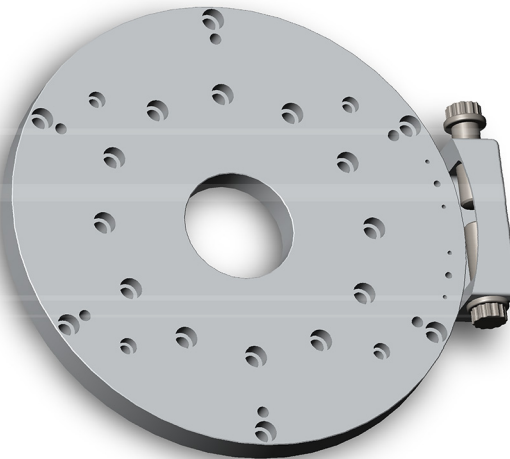
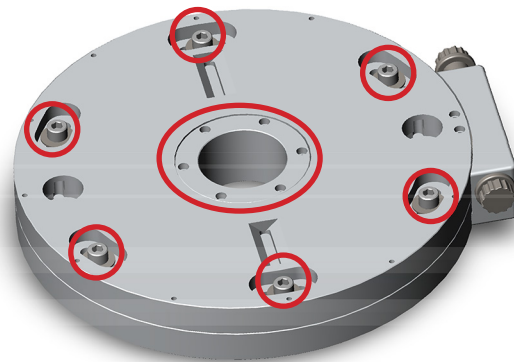
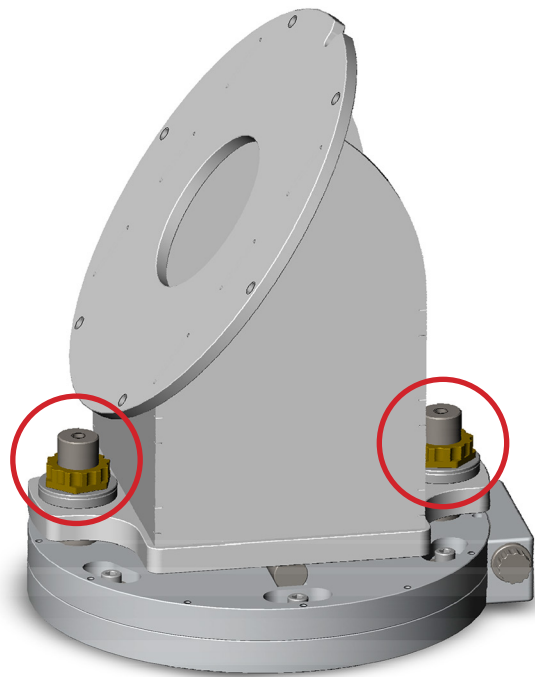

PREPARING FOR INSTALLATION

Necessary tools, equipment and people:

- SAE Hex wrenches / T-handle wrenches with key sizes up to 3/8". Almost all of the fasteners you will have need to remove, install, or adjust will require these hex-keys.

- An SAE socket-wrench set, with several inches of extension length is required for adjustment of the RA/Azimuth balancing mechanism.

- At least 2-3 people able to lift 75 pounds comfortably (L-500: 2, L-600: 3). Additional people or equipment (crane or fork-lift) may be needed to install the telescope OTA onto the L-series mount. Please consider the component weights (below) before assembling your team.

Alternatively, a crane or fork-lift may be used to lift and place the mount, depending upon accessibility of the observatory and pier to such equipment.

Component weights:

L-500:

Fork-assembly: 149 LBS

Drive-base: 123 LBS

L-600:

Fork-assembly: 203 LBS

Drive-base: 135 LBS

EQ Wedge (Optional): 145 LBS

Lifting points for people:

Your L-series mount should not be lifted by people when fully-assembled.

Fork-arm:

The black handles on the fork-arm assembly are excellent lifting points for that segment of the mount.

When being lifted by two people, each should grab a handle, using their other hand to support the bottom of the shorter length of the "L".

If a third person is available to help move the fork-arm, it is best for them to use both hands to help support the weight of the DEC/Altitude motor, at the end of the longer length of the "L".

Do not lift by the access-panel cover handles!

Drive-base:

There are no handles available to lift the drive-base. Instead, the black-anodized mounting-plate that attaches to the fork-arm assembly should be used to lift.

With two or more people, each using both hands, grip at even intervals around the upper mounting-plate to fairly distribute the load.



Lifting Points for crane/lift:

Nylon straps should be used to make lifting contact with the mount, when a crane, fork-lift, or other mechanical lift is used.

For Alt-Az installation:

Use a single strap, looped through the Altitude-Axis pass-through. This can only be done when the saddle-plate is not installed.

For EQ installation:

Use two straps to hold from both the DEC-axis pass-through and around the top of the drive base. When wrapping the strap around the drive-base, have it extend toward the lift on the side of the drive-base that is opposite the fork-arm, and wrapped at least once around the side of the drive-base adjacent to the fork-arm.

The relative lengths of these straps should be adjusted so that the mount becomes suspended at an angle approximately equal to the inclination of the wedge's mounting surface, simplifying the process of bolting the drive-base onto the wedge.

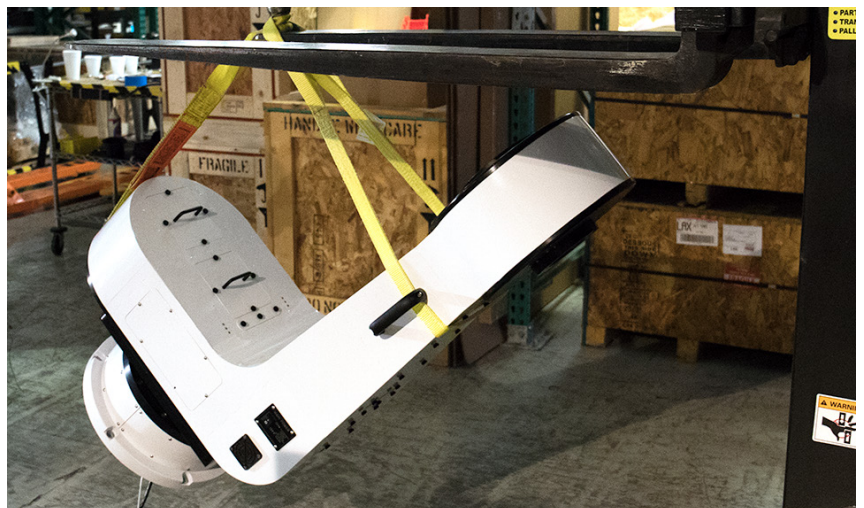

Hole pattern and pier-interface advice:

In drawings to the right, two different measurements are shown for the L-500/L-600 mounting bolt pattern. At top, the pattern is described as a 15.75" circle, with 60-degree separation between holes. At bottom, the pattern is described in X-Y measurements from center.

The interface between the pier and drive-base (or equatorial wedge, using the same pattern) should follow one of two approaches:

1) Metal piers or extensions should have their top-plates machined so as to offer threaded-holes that correspond to the drive-base's hole-pattern.

2) Concrete piers should use an intermediary interface-plate. This plate will have threaded-holes matching the drive-base's hole-pattern, and then a secondary pattern meant to accept the anchor-bolts placed in the concrete.

While it is possible to place the anchors in the concrete so as to match the drive-base's hole-pattern (offering threaded rod that would pass through the lower-flange of the drive-base's perimeter), the tolerances involved will make this difficult and mistakes will be difficult to fix. For similar reasons, attempting to drill holes in existing concrete to match the drive-base's mounting-pattern will be difficult.

The top-plate of the metal-pier or interface-plate mounted to the concrete-pier needs to be level while firmly secured to the retaining-bolts in the concrete. This should not occur through stacking washers, as increased separation of these contact surfaces risks loss of the rigidity your pier-anchoring should provide.

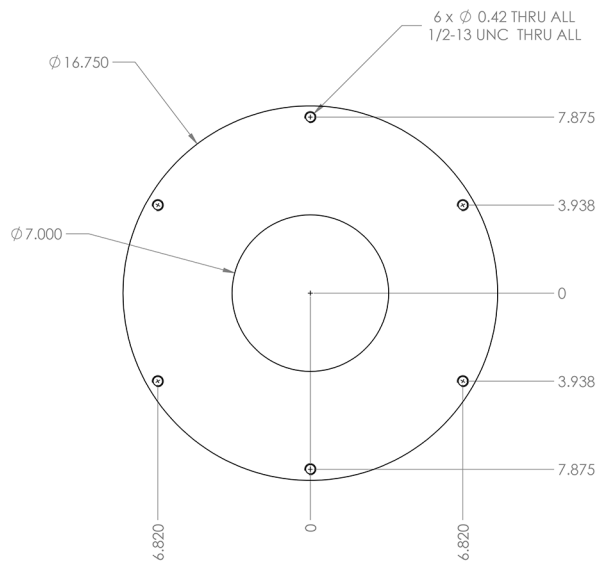
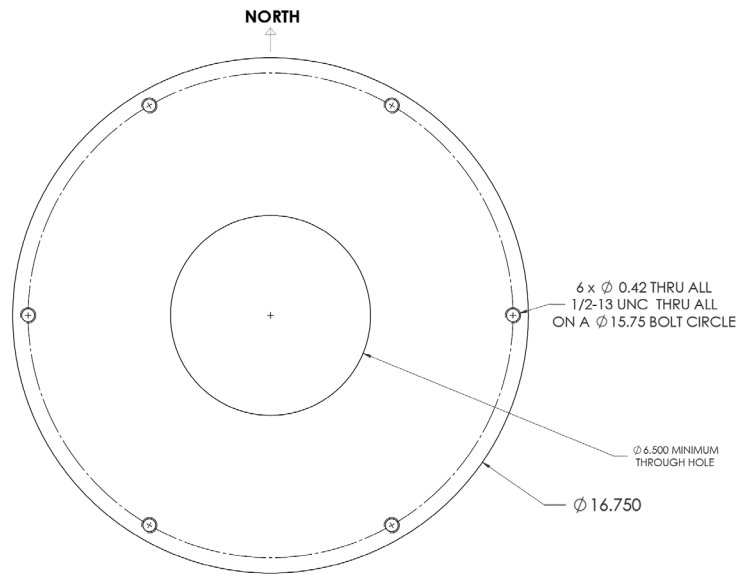

MOUNTING DRIVE-BASE TO PIER

Mounting (Alt-Az-specific concerns):

Leveling:

L-series mounts are fully capable of operating in Alt-Az when not well leveled. However, the drive-base being off level will result in the following challenges (which increase with the extent to which it is off level):

- Pointing and tracking, prior to building a model, will be incorrect and complicate the process of building an initial model.
- Balancing in Azimuth becomes more critical, to prevent this axis from wanting to rotate.

Leveling should ideally be achieved through proper construction of the pier, not through uneven elevation of the drive-base over a non-level mounting surface.

Orientation of NoWrap position:

Please note that accuracy of the NoWrap position to the cardinal directions noted below will effect tracking, prior to building a model. It is well worth taking 30 seconds with a compass or smartphone to make a modest effort to be accurate.

Northern-hemisphere:

The "NoWrap" mark on the Aziuth-Motor/Base should face true-south.

Southern-hemisphere:

The "NoWrap" mark on the Aziuth-Motor/Base should face true-north.

Installing the base motor onto the pier:

Before beginning, be sure that cable-routing has been addressed. The power and communication (USB/Ethernet) cables are meant to exit through the bottom-center of the drive-base.

If a metal pier or extension is being used, it should have holes available for both entry and exit of these cables.

If a concrete pier is being used, it should have had a conduit placed at its top-center (exiting out some position on the side of the pier) or a channel in the top (from center to edge) allowing the drive-base to sit firmly and flush on the pier without interference from the cabling.

1) Lift the drive-base onto the pier (or interface plate), making sure that the "No-Wrap" marker is correctly oriented (see above), and that cables are properly routed into/over the pier.

2) Secure the drive-base, inserting the bolts through the hole-pattern around its bottom flange and lightly tightening them. To ensure that all go in easily, wait until all are engaged before fully tightening any of the bolts.

HARD-STOP POSITIONING

Moving the Altitude hard-stop from the EQ position to the Alt position (top image, right):

When mounted in Alt-Az configuration, the L-series mount is able to operate with the Altitude hard-stop in either position. However, it may be necessary to move the hard-stop to the designated Alt-Az position for other reasons:

- Optical tubes without fully secured optics. If it is possible for the telescope's optics to tip out of their cells or mountings when the telescope is pointed below the horizon, it will be necessary to move the hard-stop to prevent the telescope from achieving such elevation-angles.

- Clearance and observatory safety. If there are physical obstructions in the observatory that will prevent full and free motion of the mount, with it achieving negative elevation-angles, the hard-stop must be moved to the Alt-Az position. Similarly, if the mount is atop an elevated pier, and negative elevation-angles create a safety hazard for observatory occupants, the hard-stop should be moved.

If necessary, or preferred, moving the Altitude hard-stop to the Alt-Az position is relative simple:

- 1) Begin by removing both the hard-stop assembly and the cover for the position currently not in use. Each part has four bolts that secure them to the Altitude assembly (these bolts are at the corners of each plate, DO NOT remove the other 2 bolts). (bottom image, right)

- 2) Swap their positions, while not rotating the hard-stop assembly, and reattach.

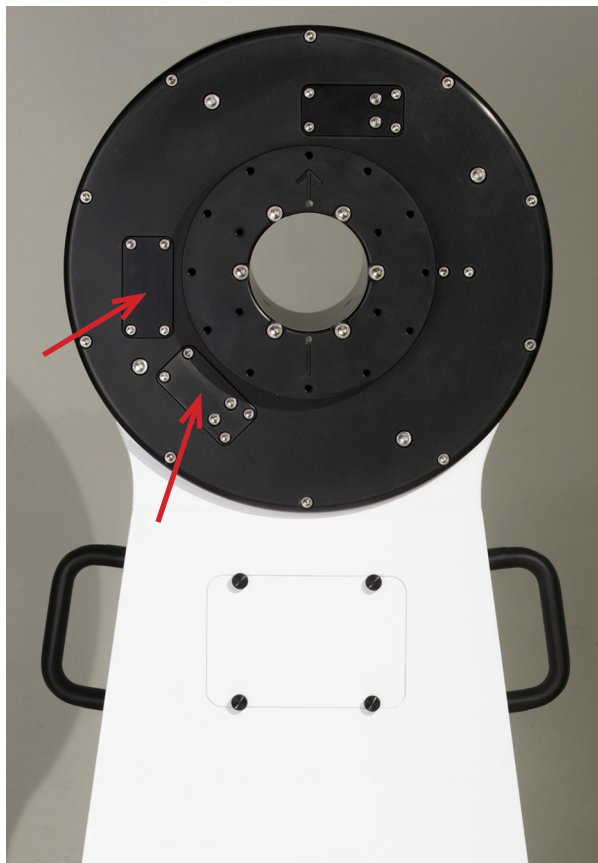

INSTALLING EQ WEDGE

Leveling:

Leveling of the wedge, while not critical to the system's operation, needs to be reasonably close to ensure polar-alignment can be reached. This is particularly important if your observatory is at a latitude that is near either limit of your wedge.

Leveling should be achieved through proper construction of the pier, not through uneven elevation of the equatorial-wedge over a non-level mounting surface.

Installing the wedge:

The L-Series equatorial wedge should be assembled on the pier, to prevent its full weight from needing to be lifted.

1) Begin by bolting the lower mounting plate onto the mounting surface of your pier. In the northern-hemisphere, the azimuth adjustment-mechanism will be on the south side of the pier. In the southern-hemisphere, the adjustment mechanism will be on the north side of the pier.

2) Place the upper mounting plate onto the lower mounting plate, and slide the azimuth-adjustment tab into the azimuth-adjustment mechanism.

3) Locate the azimuth-rotation hub and apply a small amount of grease, to prevent galling or unnecessary resistance to motion in the wedge's azimuth axis.

4) Insert the hub through the top-plate, so that it extends into the base-plate, and then bolt it onto the top-plate.

5) Now, attach the top-plate to the base-plate with the 6 bolts passing through the top-plates slotted pattern.

6) Now lift the wedge assembly onto the assembled base/top plates, and set the rocker-pins into the corresponding detents in the upper surface of the top-plate.

7) Finally, secure the upper wedge assembly to the top-plate using the 2 altitude-adjustment bolts. These should be fully tightened prior to installation of any part of the mount.

TIP:

Before installing the base-motor assembly, it is helpful to intentionally set the wedge too high in elevation, so that the resulting polar-alignment correction will be in the direction of gravity.

DRIVE-BASE ATTACHMENT TO WEDGE

1) Flip the drive-base over, so that its lowest surface is facing up. Do this on a surface that will not damage the shoulder-bolts (highlighted in the photo to the right).

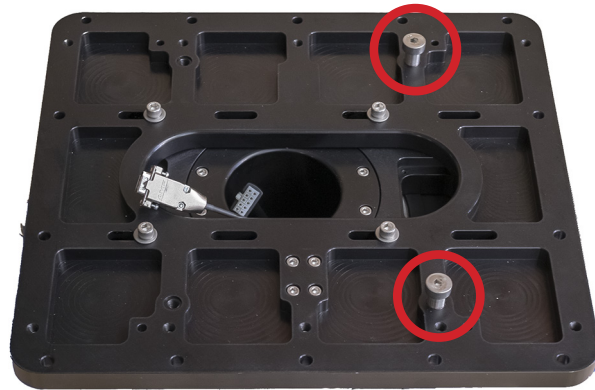

2) You will now be able to see a bolt-hole near the perimeter of the drive-base's bottom that is non-symmetrical with the rest of the hole-pattern and is threaded (the symmetrical perimeter pattern is comprised of pass-through holes). Insert and tighten the wedge-mounting shoulder-bolt into this hole. It will help position the drive-base on the wedge, while you next begin to attach the two assemblies. (middle image, right)



3) Have a friend help lift the drive-base onto the wedge, oriented so that the shoulder-bolt that was just installed settles into the notch at the top of the wedge. (bottom image, right)



4) Now, shift the drive-base, as needed, to line up the pass-through holes in the drive-base with the corresponding threaded-holes in the wedge.

5) Beginning with the pair of holes nearest the top of the wedge, begin inserting and threading the bolts. To ensure that all go in easily, wait until all are engaged before fully tightening them.

INSTALLING FORK-ARM

The procedure for installing the fork-arm onto the drive-base is common to both ALT/AZ and EQ configurations.

1) First, confirm proper orientation of the fork-arm, relative to the drive-base. Essentially, you are going to do the reverse of the disassembly process that occurred during unpacking. If the drive-base is wedge-mounted, be sure that the base's interface-plate is rotated so that gravity will help slide the fork-arm's shoulder-bolt slots into the "locked" position (where the shoulder-bolts will prevent the fork-arm from tipping/sliding off of the drive-base). (image top, right)

2) Check tensioning of the azimuth locking-knob. If properly engaged, it will prevent unwanted rotation of the drive-base's interface-plate. (refer to bottom photo on page 12, UNPACKING)

3) If they are not already removed, remove the side-access panels on the lower section of the fork-arm, to allow visibility of the slotted holes that receive the shoulder-bolts attached to the drive-base's interface-plate.

4) Make sure that the power/com cables for the Azimuth/RA motor are safely out of the way, and will not be snagged or sheared during mounting of the fork-arm. (image bottom, right)

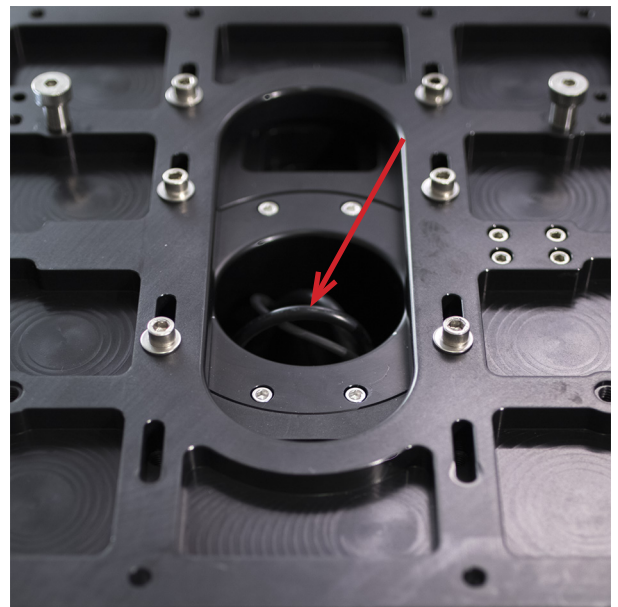
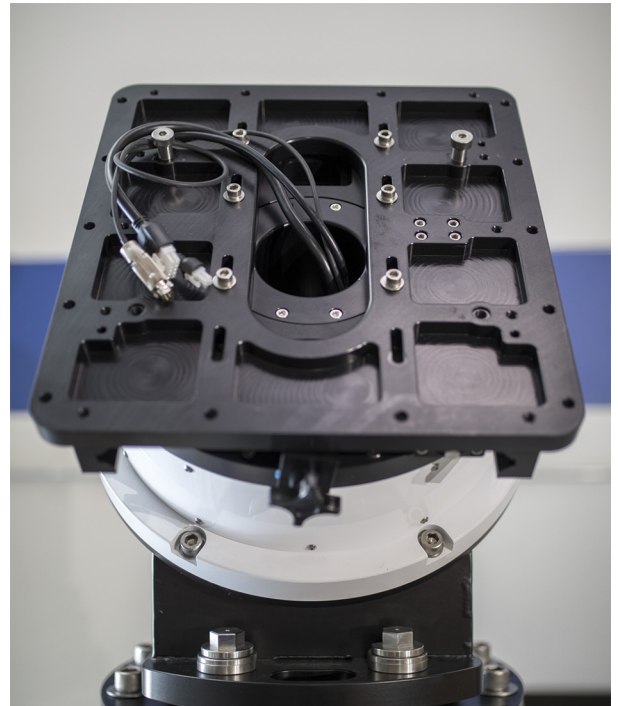

5) With the help of at least one person, lift the fork-arm onto the drive-base. (image top, right)

Pay careful attention to the position of the shoulder-bolts on the interface-plate and the corresponding slotted holes in the lower section of the fork-arm. (image bottom, right)

Place the larger portion of the slotted-holes over the shoulder bolts.

6) Slide the fork-arm relative to the drive-base to engage both shoulder-bolts in the narrower portion of the slotted-holes.

7) Tighten the 6 bolts in the slotted-holes within the interior of the fork-arm, and reinstall and tighten the 2 bolts you had removed and set aside during the unpacking process. Refer to bottom image on page 9, UNPACKING.

8) Reinstall and tighten the 14 bolts around the perimeter of the bottom of the black-anodized interface-plate between the fork-arm and drive-base. Refer to photos on page 9, UNPACKING (2).

9) Reconnect the power/com cables for the Azimuth/RA motor to the printed circuit board in the fork-arm (behind the side access panel on the lower section of the fork-arm, on the opposite side from the power-switch). Refer to top three images on page 10, UNPACKING.

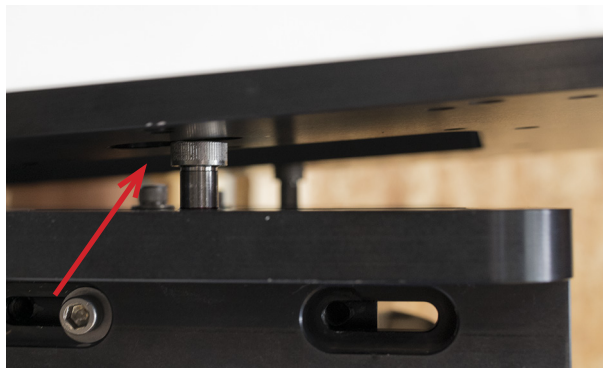

MOUNTING SADDLE

Installing equipment for mounting the main optical-system:

Your L-500 mount has been shipped with a dovetail saddle. Installation is achieved by bolting the saddle to the hole-pattern on the interior of the Altitude/DEC axis mounting assembly:

1) First, make sure Alt/Dec axis is oriented correctly. The mounting surface for the saddle features an engraved arrow (image top, right). This arrow should always indicate the pointing direction of the telescope. So the saddle should be attached with its longer dimension parallel to the arrow. It may be helpful to use a small piece of tape to mark the end of the saddle that corresponds to the arrow's direction.

2) Now, use a hex-key to insert and tighten the bolts that were included with the saddle (image bottom, right).

TIP: If you ever lose "sight" of the sky-side of the saddle, note that this edge of the saddle will be the one pointing up, when the Altitude/DEC axis is against the zenith/pole hard-stop. This position is achieved by rotating the Alt/DEC axis fully clockwise when viewed from the interior side of the fork-arm.

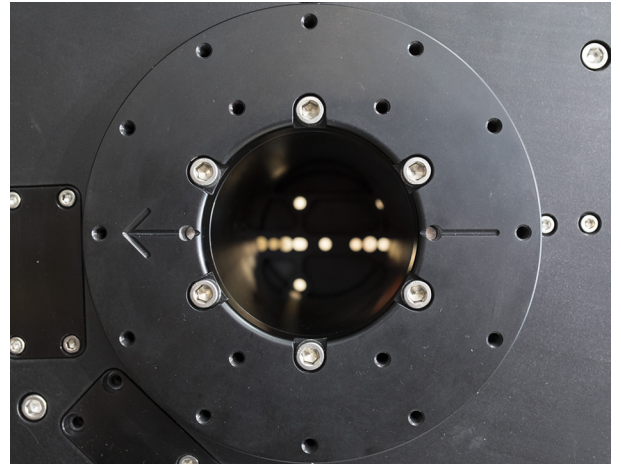

PREPARING OTA

If you have access to equipment (crane or fork-lift) or a sufficient number of assistants, there are advantages to pre-installing your camera and other instrumentation onto the telescope. This will increase the overall weight of the OTA, and the expense of the equipment being lifted at one time. However, you will see significant savings of time and effort when later adjusting balance in the Alt/DEC axis.

Locate the OTA's center-of-mass and the corresponding position on the dovetail. This is most easily done through use of a wooden dowel, or other small, sturdy cylinder:

1) Place the dowel on the ground (or table), next to the OTA. It should be perpendicular to the length of the dovetail and the tube's optical-axis. (image top, right)



2) Have a friend help lift the OTA and set it down, dovetail first, onto the dowel. You should now be able to roll the dovetail atop the dowel, and have created a "seesaw". The position on the dovetail that corresponds to the OTA's center-of-mass has been found where the system balances on dowel. (image middle, right)



3) Use a piece of tape (or white grease-pencil) to mark the dovetail at this position, so that it will be easily visible while loading the OTA. If only marking one side of the dovetail, this should be done on the side that is to your left when looking down the front-end of the telescope. (image bottom, right)



PREPARING SADDLE FOR OTA

1) Rotate the saddle so that it is ready to receive the OTA. This will have it turned at a right-angle relative to the length of the fork-arm. The side you previously marked to indicate the “sky side” of the saddle should be pointed opposite of the mount’s power-switch.

2) Install the locking-knob for the Altitude/DEC axis. While you will remove the lock during the balancing process, it is safest to have this in place during initial mounting of the OTA.

3) If using an equatorial wedge, be sure the Azimuth/RA axis is rotated so that the shoulder of the fork-arm is nearest to the ground. (image top, right)

4) Securely tighten the Azimuth/RA axis locking cleat. This will help stabilize the mount while the OTA is being loaded, and does not apply any stresses to the Azimuth/RA motor. (image bottom, right)

5) Remove the four bolts on the current upper-side of the saddle, and remove the jaw that becomes detached. The jaw and bolts should be kept nearby. (image below)

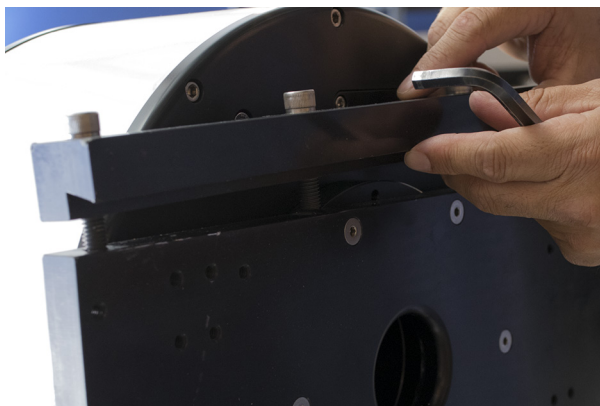

POSITIONING OTA

1) Lift the OTA up and onto the saddle. This process requires at least 2 people. Additional people will be needed for larger optical-tubes, and where weight/person considerations require more for a comfortable and safe lift. (image top, right)



Be sure that the rear-cell of the telescope is on the same side of the mount as the power-switch located on the fork-arm.

2) Rest the lower edge of the telescope's dovetail on the saddle's attached jaw, so that the two are fully mated. (image middle, right)

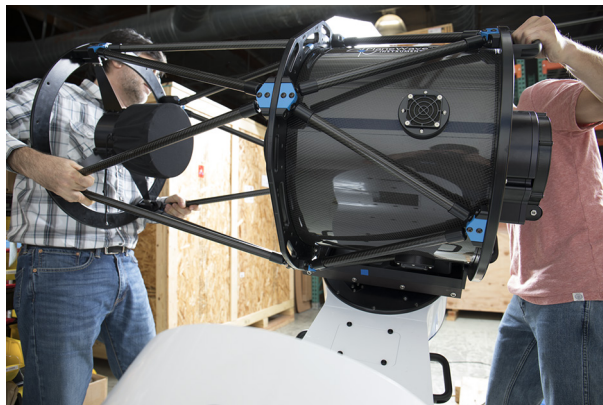

3) Slide the dovetail along the saddle's jaw until the tape or mark you used to reference the Alt/DEC balance-point (page 25, PREPARING OTA) is positioned directly above or below the saddle's rotational axis while the saddle is square to the length of the fork-arm. (image bottom, right)



SECURING THE OTA

Reassemble and tighten the saddle jaw you previously removed.

If less than 3 people are involved in this process, it should be the person that lifted the rear of the OTA that reassembles the saddle. This is due to the OTA's center of mass being closer to the rear-cell, and so more easily controlled from that end. The second person should step to the side opposite the saddle to help maintain full contact between dovetail and saddle. (image top, right)



1) Begin inserting and partially tightening the saddle-jaw's bolts, through the saddle jaw. Make sure they are tightened at least 2-3 turns, but do not fully tighten them yet.

2) With the OTA naturally wanting to roll away from the fork-arm, it is necessary for the person (or people) still holding the OTA to apply pressure upward and toward the saddle. Otherwise, proper assembly of the saddle will not be possible, due to wedge between the saddle and dovetail. The photo to the right (middle) shows unwanted wedge in the interface.

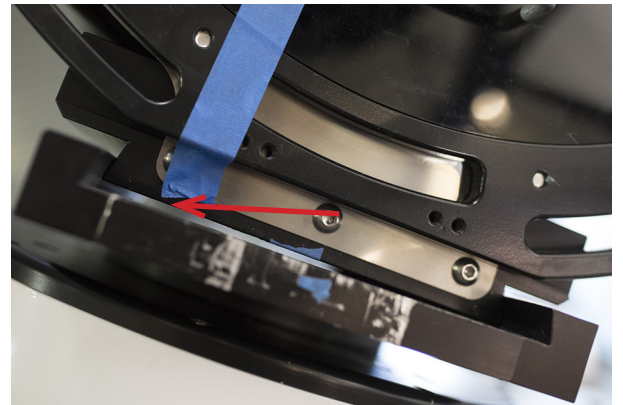

3) Being sure that the dovetail is properly seated in the saddle, proceed in fully tightening the saddle-jaw's bolts. (image bottom, right)

4) Double-check that the dovetail is fully seated and secured in the saddle before everyone lets go.

5) Remove the Altitude/DEC axis locking-knob.

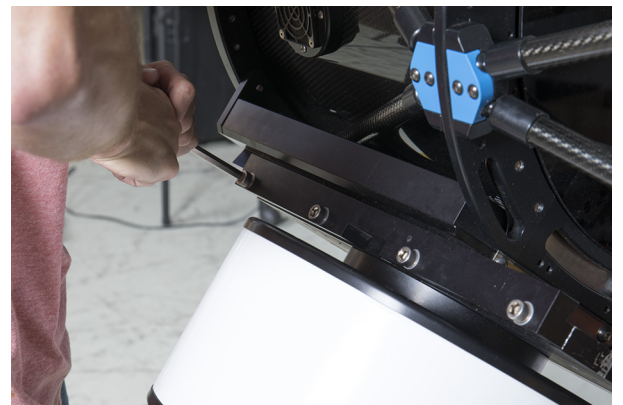

INSTALLING SECOND SADDLE

The particular details of assembling may deviate from the preceding instructions, specifically relating to the bolt-pattern used to attach the secondary saddle (the full bolt-pattern for the outer mounting surface is shown to the right). The basic principles of attaching the secondary saddle are the same as for the primary.

Both mounting surfaces of the Altitude/DEC axis feature bolt-patterns that will accommodate the larger PlaneWave Saddle (for CDK17 and larger) and the Keller EZ-Saddle (for the CDK12.5, CDK14 and compatible with Losmandy D-series style dovetails, and similar from Celestron, Meade, ect.).

Mount the saddle:

- 1) Ensure that the hole-pattern used causes the secondary-saddle to point at the same angle as the main OTA's saddle.
- 2) Fully assemble and install the secondary telescope's instrumentation (if possible).
- 3) Find the secondary OTA's center of mass, and accordingly mark the dovetail for reference of balance during mounting.
- 4) Prepare the saddle to receive the telescope's dovetail (varies by saddle).
- 5) Lift the telescope into the saddle.
- 6) Slide the dovetail within the saddle to place the balance-mark above the rotational-axis.
- 7) Engage the saddle, ensuring that the dovetail is properly seated and secure before letting go.

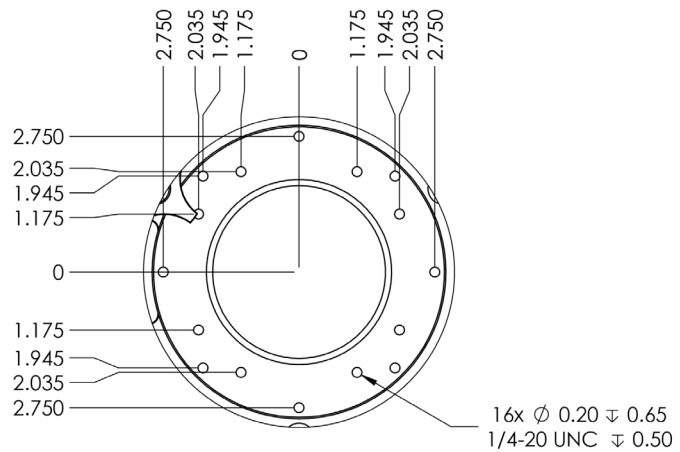

DETAIL E
OUTER SCOPE
MOUNTING HOLES

BALANCING: ALTITUDE/DEC

If your saddle features an optional balancing aid (for pushing/sliding the dovetail within the saddle), which is not yet installed, install it now.

First, roughly balance the Altitude/DEC axis of the system:

If you followed the preceding guidance regarding finding, marking, and placing the center-of-mass reference, rough balance should already be achieved.

Any additional adjustment to balance must be made similarly:

- 1) Slightly loosen the bolts on the saddle's jaw.
- 2) Adjust the position of the dovetail/OTA as follows:

If the back of the telescope is heavier:

Tighten the balancing-aid, so as to bring the rear-cell closer to the rotational-axis. This should be done with the OTA pointed at the horizon (or slightly downward, if the adjustment is too difficult at level).

Without the balancing aid, it is recommended that two people are involved. Push/pull the telescope so that it slides forward in the saddle. With care, the telescope can be pointed slightly downward, allowing gravity to help slide the telescope within the saddle.

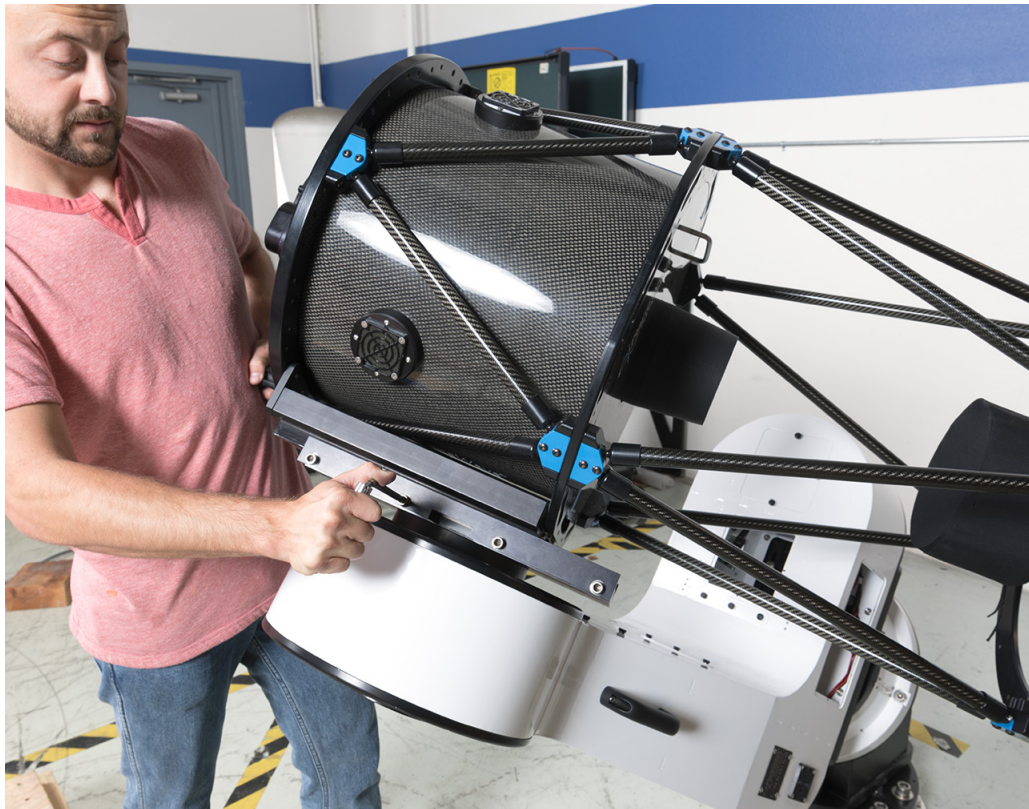

If the front of the telescope is heavier:

Retract the balancing-aid, with the telescope pointed well above the horizon, so that the dovetail easily slides and remains engaged with the balancing-aid.

Without the balancing aid, it is recommended that two people are involved. Push/pull the telescope so that it slides backward in the saddle. With care, the telescope can be pointed upward and allowed to slide within the saddle.

3) Retighten the saddle.

4) Check balance and repeat the above as needed, until the Altitude/DEC axis is balanced well enough to not settle with the brake engaged.

5) Install any other instrumentation (cameras, filter-wheels, finders, focusers, guide-scopes, etc.) that will be part of the system, and then rebalance.

Be sure that all planned cable-runs have been completed (for power/com to instrumentation and accessories) before determining final balancing. Recommendations on cable-routing are covered later in this manual.

6) Now refine balance as needed. The process will be identical to the process of achieving rough-balance, except the adjustments will be smaller. Continue refining balance until the system does not "settle" (i.e. move without force applied) in the Altitude/DEC axis.



BALANCING: AZIMUTH

While evidence of balance in the Azimuth axis is less obvious than Altitude, significant imbalance of this axis will impact tracking performance.

Given the difficulty of measuring balance, at least when the drive base is properly level, there are a number of recommended balance positions for Azimuth axis based on installed equipment:

L-500:

CDK20 with CCD camera, CFW, and focuser (XX.X LBS):

CDK17 with CCD camera, CFW, and focuser (XX.X LBS):

L-600:

CDK24 with CCD camera, CFW, and Focuser (XX.X LBS):

When adding additional equipment/weight move the fork-arm outward from the positions noted above by the following ratios:

L-500:

CDK20: X.XX"/10LBS

CDK17: X.XX"/10LBS

L-600:

CDK24: X.XX"/10LBS

Adjusting balance for the Azimuth axis:

1) Begin by removing the 8 bolts that lock the jaws of the saddle between the fork-arm and drive-base. These are located in the slotted holes along the sides of the saddle, and run parallel to the ground (image top, right). Do not loosen or remove any of the other bolts on the exterior of the saddle mechanism.



2) Next, remove the access panel on the top of the fork-arm's lower-section, closest to the fork-arm. This should allow you to see the cable pass-through at the center of the RA axis, as well as a series of 8 bolts in slotted-holes. (image middle, right)



3) Loosen the 8 bolts in the slotted-holes enough for the washers to be able to be wigged or turned. Do not remove them unless you find that reaching balance requires enough change in position for them to need to move to the next set bolt-holes (the patterns are designed to allow the slots to line up with different sets of holes, as the dovetail and saddle shift for balancing adjustments).

4) It is now possible to move the fork-arm with the saddle's lead-screw mechanism. Clockwise motion of the lead-screw will move the fork closer to the Azimuth axis's center-of-rotation. Counter-clockwise motion of the lead-screw will move the fork further from the Azimuth axis's center-of-rotation.

5) Adjust the position of the fork-arm, relative to the drive-base, as indicated by the preceding rules.

6) Tighten the bolts in the slotted-holes on the interior of the mount, and replace and tighten the bolts you removed from the exterior sides of saddle-interface between the fork-arm and drive-base.



BALANCING: RA

Balancing of the RA axis is necessary for proper tracking performance of your L-500 mount. Due to the fact that this axis is not perpendicular to gravity, balancing of RA is much more important and unique to each system configuration than this axis when configured in Alt/Az. RA should be balanced well enough at the end of this process that the system is capable of being pointed at any achievable position without settling.

Before beginning, make sure that the optional RA counterweight-assembly, if purchased, is installed and centered within its range of adjustment.

1) Remove the 8 bolts that lock the jaws of the saddle between the fork-arm and drive-base. These are located in the slotted holes along the sides of the saddle, and run parallel to the ground (do not loosen or remove any of the other bolts on the exterior of the saddle mechanism). (image top, right)

2) Remove the access panel on the top of the fork-arm's lower-section, closest to the fork-arm. This should allow you to see the cable pass-through at the center of the RA axis, as well as a series of 8 bolts in slotted-holes. (image bottom, right)

3) Loosen the 8 bolts in the slotted-holes enough for the washers to be able to be wiggled or turned. Do not remove them unless you find that reaching balance requires enough change in position for them to need to move to the next set bolt-holes (the patterns are designed to allow the slots to line up with different sets of holes, as the dovetail and saddle shift for balancing adjustments).



4) It is now possible to move the fork-arm with the saddle's lead-screw mechanism (image top, right). It is often necessary to use a socket-wrench extension to properly reach the interface.



Clockwise motion of the lead-screw will move the fork closer to the Azimuth axis's center-of-rotation. Counter-clockwise motion of the lead-screw will move the fork-arm further from the Azimuth axis's center-of-rotation.

5) Adjust the position of the fork-arm, relative to the drive-base, as follows:

If the fork-arm wants to settle towards the ground, the adjustment needs to be move toward the center-of-rotation.

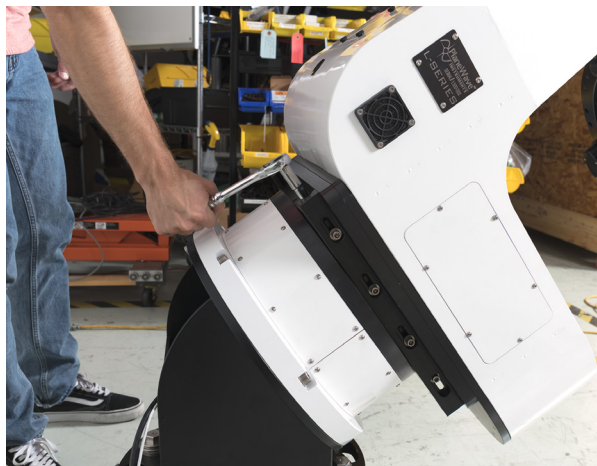

If the fork-arm settles away from the floor, then the needed adjustment moves the fork-arm further from the rotational axis.

Making these adjustments will be easiest if you rotate the RA axis so that gravity pulls the fork-arm in the desired direction. If using this technique, be sure to have hold of the system to prevent it from moving unexpectedly.

6) Refine balance in the RA axis until it is possible to point the telescope at any achievable angle without settling in this axis.

7) Rotate the RA axis so that the length of the lower section of the fork-arm is parallel to the ground, and then tighten the bolts in the slotted-holes on the interior of the mount. These bolts should be retightened after then rotating the RA axis 180 degrees.

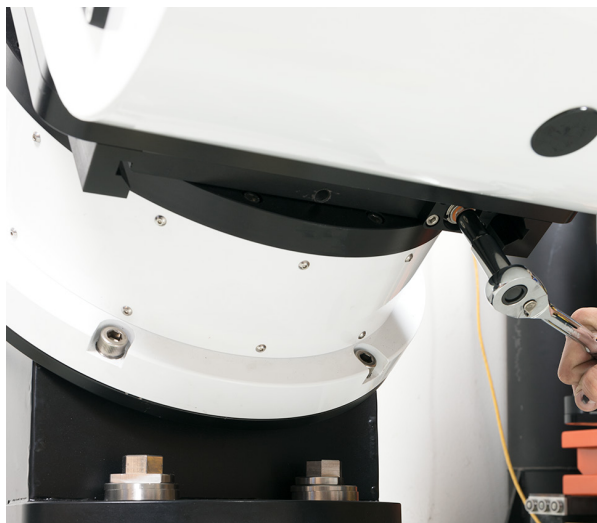

8) Replace and tighten the bolts you removed from the exterior sides of saddle-interface between the fork-arm and drive-base, as well as the access-panel covers.

POWER/COM CABLING FOR MOUNT

The L-Series mounts are shipped with internal wiring for motors and encoders pre-installed. However, the main AC power-cord and USB (or optional Ethernet) cable are not installed prior to shipment. Both AC and communication cables must be connected before the mount can be operated.

Connecting the AC power-cord and USB cable:

1) Plan the path:

The AC power-cord socket and USB cable socket are located within the mount cavity below the access-panel that is centered on the top of the lower section of the fork-arm. They will be fed through the cable pass-through at the RA/ Azimuth Axis center-of-rotation. Whether it will be more convenient to drop through from above, be pushed up from below, or pulled up from below by a tether is ultimately related to the cable-routing that will take place through the pier and beyond.

2) Plug in:

Plug each cable into its respective socket, inside the mount. Then attach to the AC source and USB port on your PC or hub.

If Ethernet will be used for PC/mount communication, instead of USB, cable-routing will proceed identically. The Ethernet socket is located on the same electronics panel as the USB socket.

CABLE ROUTING FOR ACCESSORIES

Both the L-500 and L-600 offer an appreciable volume of storage space within the fork arms' cavities. The resulting compartments offer routes back to the RA/Azimuth motor pass-through, and allow the storage of accessory power supplies, USB hubs/extenders, network switches, and other small devices. Cabling that needs to run between these peripheral devices and the outside world will be routed through the RA/Azimuth pass-through, as described for the mount's power/com cabling on the previous page.

In the highlighted drawings to the right, you will see views of top, inside fork-arm surface, and outside fork-arm surface, in descending order. The green-highlighted, smaller panels should be used to pass cables from within the mount. The yellow-highlighted panels can be used to place items, such as power-supplies (for camera, EFA, etc.), within the compartments.

The compartments that stow the mount's electronics have access-panels attached with button-head screws. Compartments meant for accessory storage use panels attached with thumb-screws.

Before placing power-supplies or other peripheral electronics within the mount, plan out your cable runs to be sure you have enough length in the right places. Remember that when using the suggested (green) panels for your cable-runs to the rear of the telescope, the longest distance will be required when telescope is pointed at the horizon (Alt-Az) or the horizon opposite the celestial pole (EQ).

Caution: Unnecessarily long cable runs between the mount and OTA increases the chance of snags. Also, be certain your cable runs avoid the area of the fork-arm that can be covered by the dovetail/saddle, to avoid "scissoring".

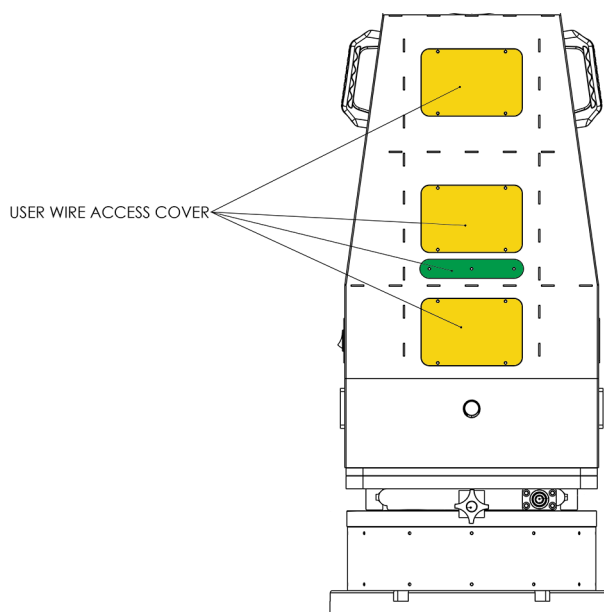
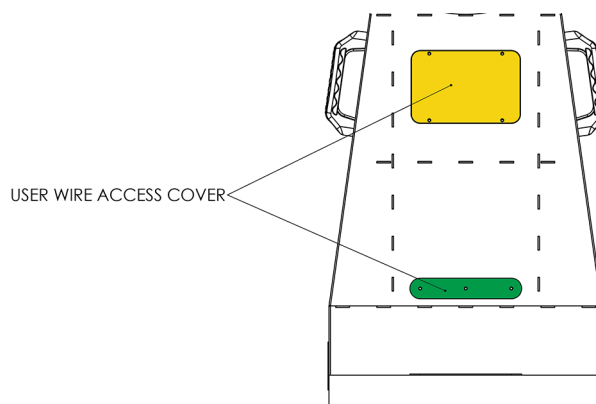
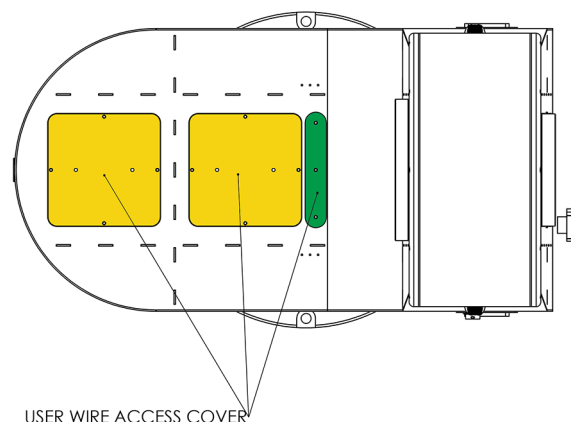

DIRECT DRIVE AUTOTUNER

The direct-drive motors in PlaneWave's L-series mounts provide unparalleled tracking accuracy at both low and high velocities, all while running virtually silently. To streamline the setup of your direct-drive mount and to ensure optimal movement from your mount, PlaneWave has developed AutoTuner.

First, review the PWI4 software user manual here: <https://planewave.com/download/pwi4-software-user-manual/>

To watch our AutoTuner YouTube video please click: <https://youtu.be/5xxELoS67uU>

Before running the PWI4 AutoTuner function complete the following steps:

1. Balance your L-series mount until both axes do not significantly drift away from a resting position when the mount is moved by hand. If either mount axes quickly move away from a resting position then your system is not balanced well enough. **Balance is key for optimized direct drive motor performance, please take your time to get this step correct!**
2. Ensure all bolts on your system, include imaging gear, are firmly tightened.
3. Ensure the L-series mount USB is connected into the observatory computer.
4. Ensure the L-series is powered on.
5. Open PWI4 software.
6. In PWI4 go to **Commands > Motor Tuning > Run AutoTuner**.

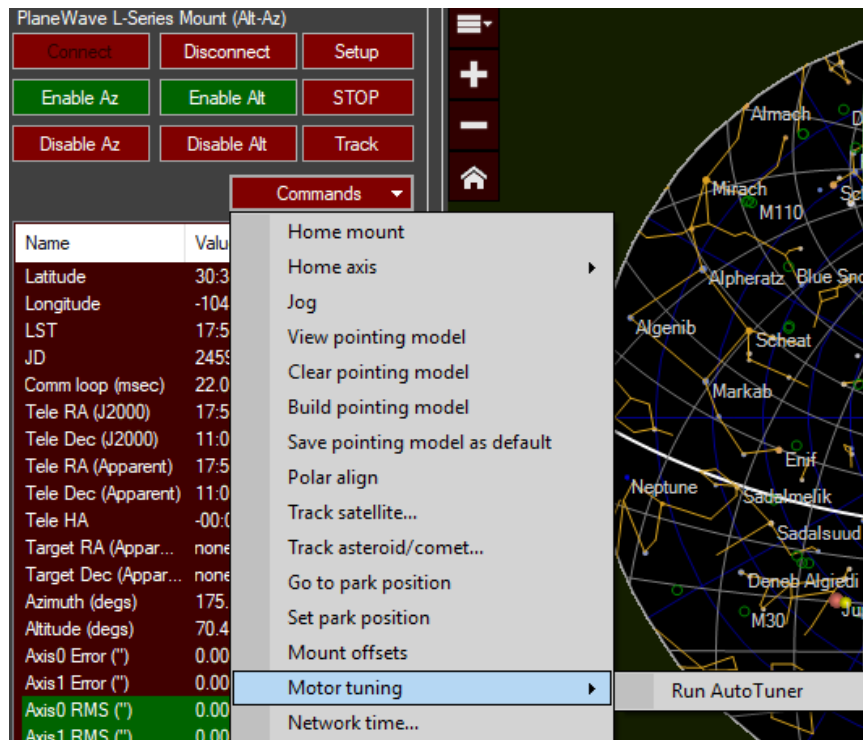

DIRECT DRIVE AUTOTUNER

7. Connect to the mount and click **Measure payload (frequency sweep)**.

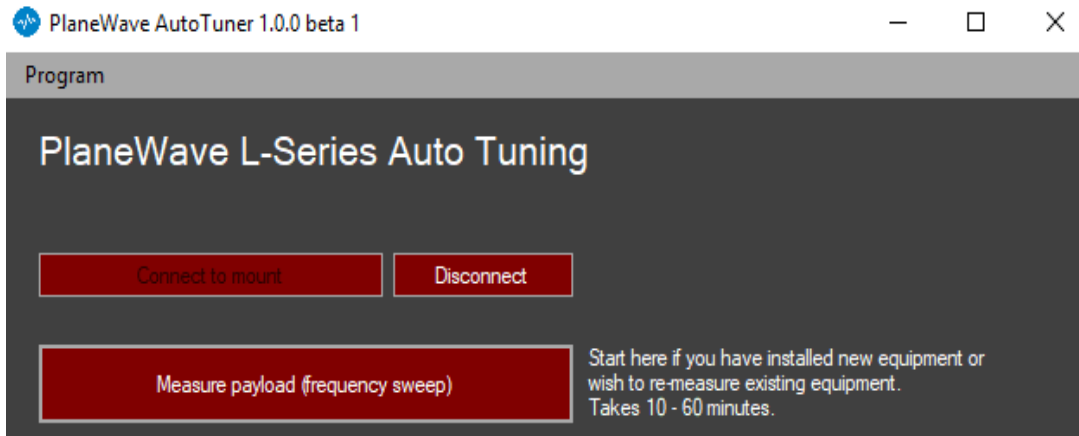

8. Click **Next** acknowledging you have tightened all the bolts on your gear and that the system is well balanced.

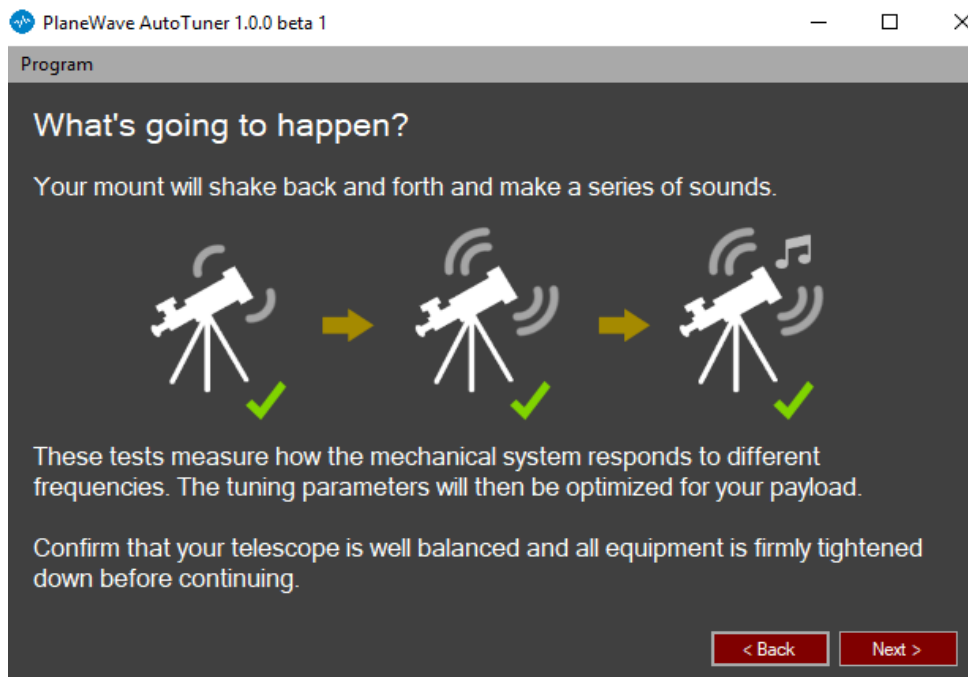

DIRECT DRIVE AUTOTUNER

9. Select your mount geometry.

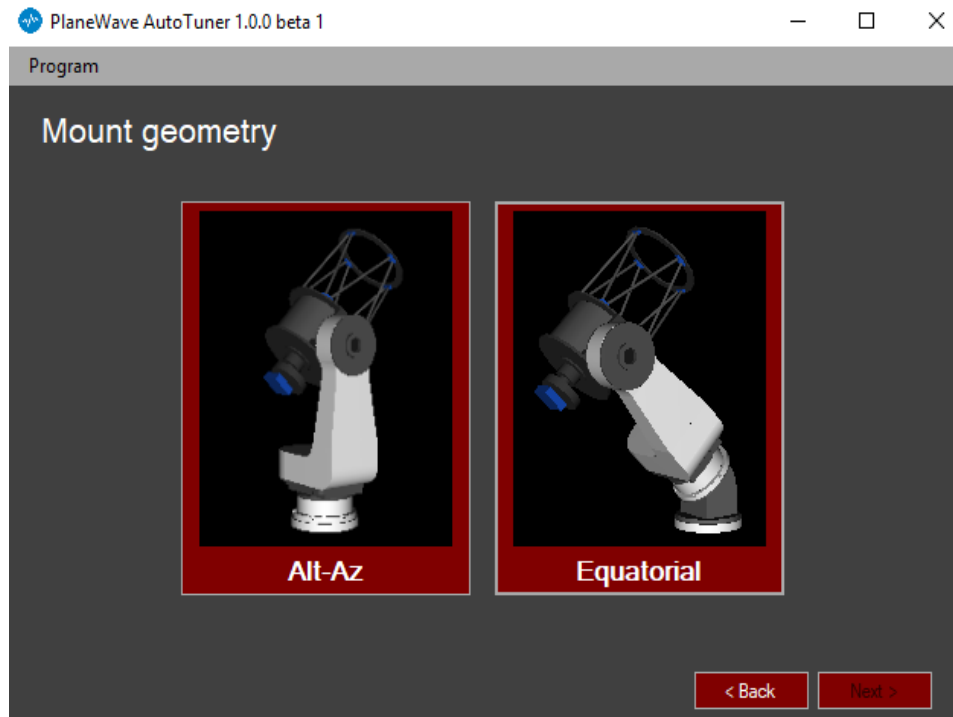

10. Select your telescope and accessories then click **Next**.

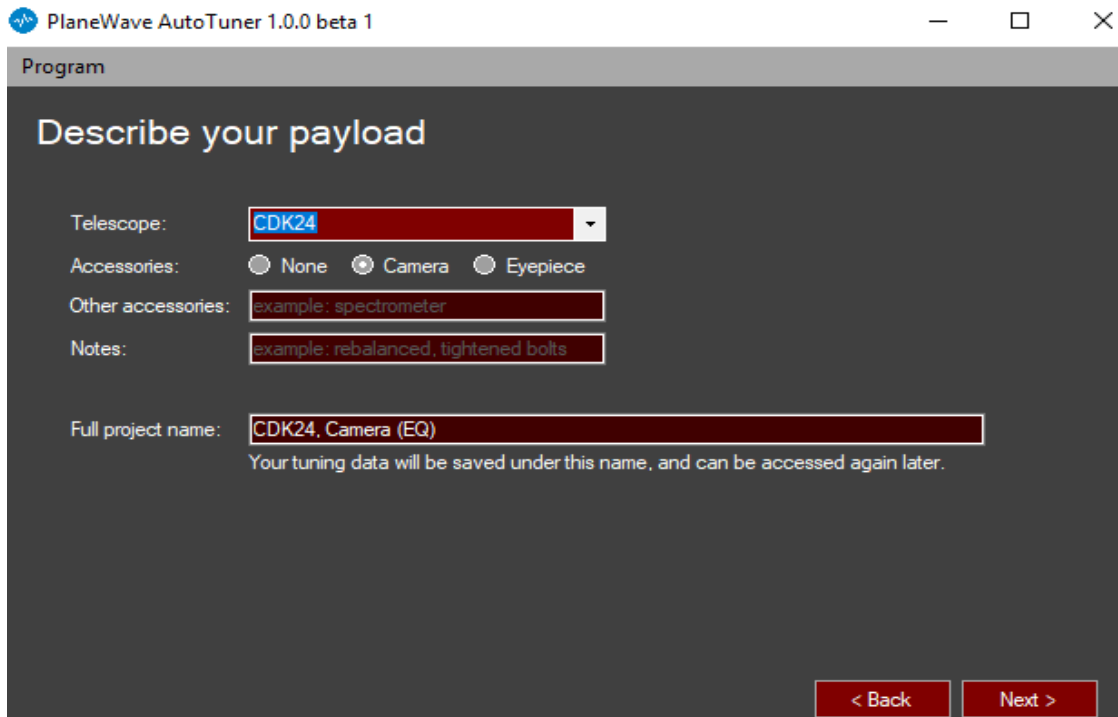

DIRECT DRIVE AUTOTUNER

11. Select Both Axes and a Normal scan density then click **Next**. Some systems might benefit from a Thorough scan density, so if your first motor tuning requires adjusting then please attempt a Thorough scan density.

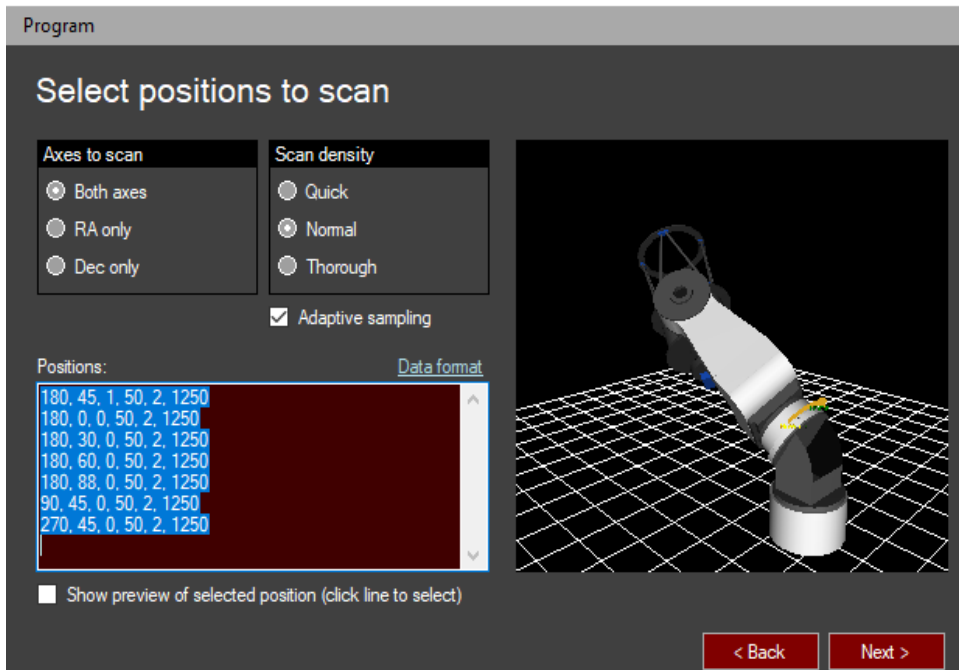

12. Click **Next** and allow the AutoTuner to run through the full sequence.

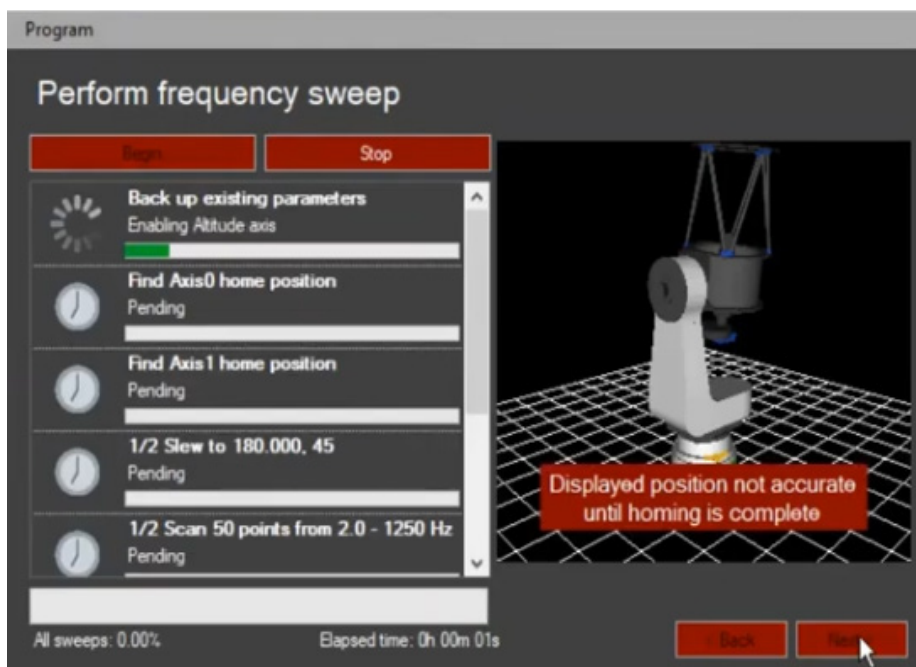

DIRECT DRIVE AUTOTUNER

13. After the AutoTuner frequency sweeps have completed then analyze will occur. After the both axes have been analyzed then click **Send tuning parameters to mount**.

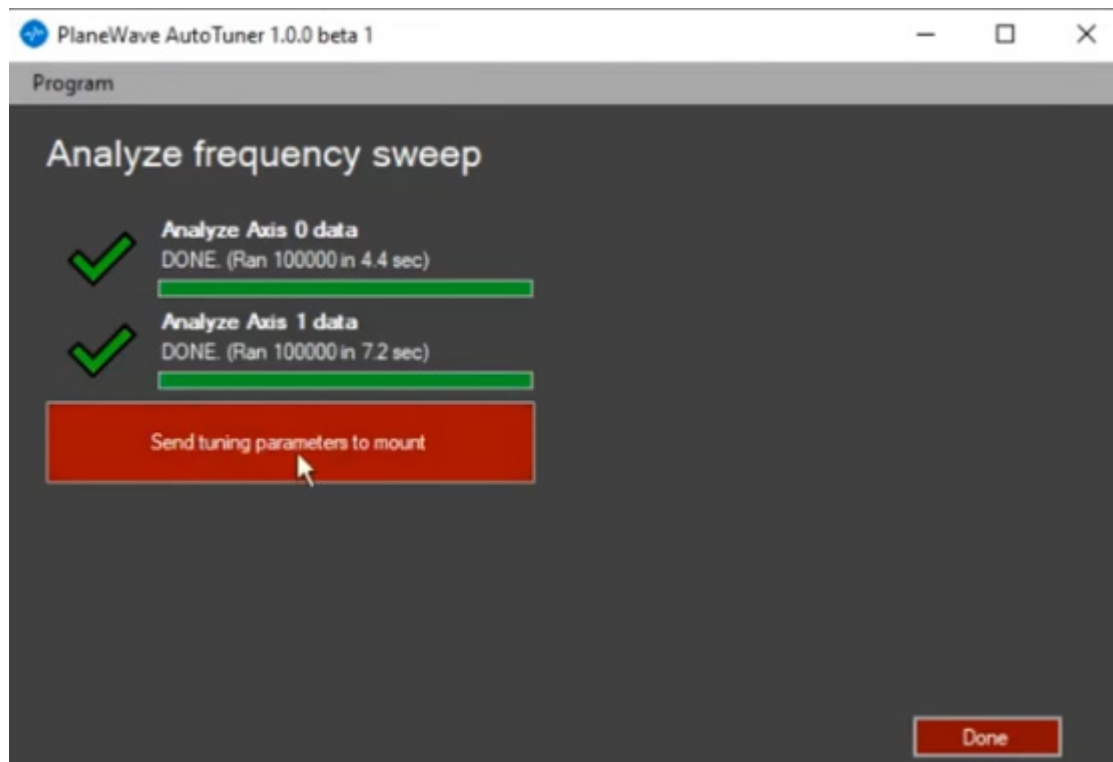

14. Click **Done**.

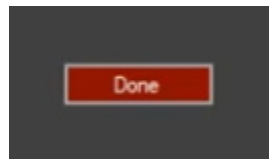

DIRECT DRIVE AUTOTUNER

15. Click **Disconnect** and then you can connect to both axes in PWI4 and home the mount under the Commands menu.

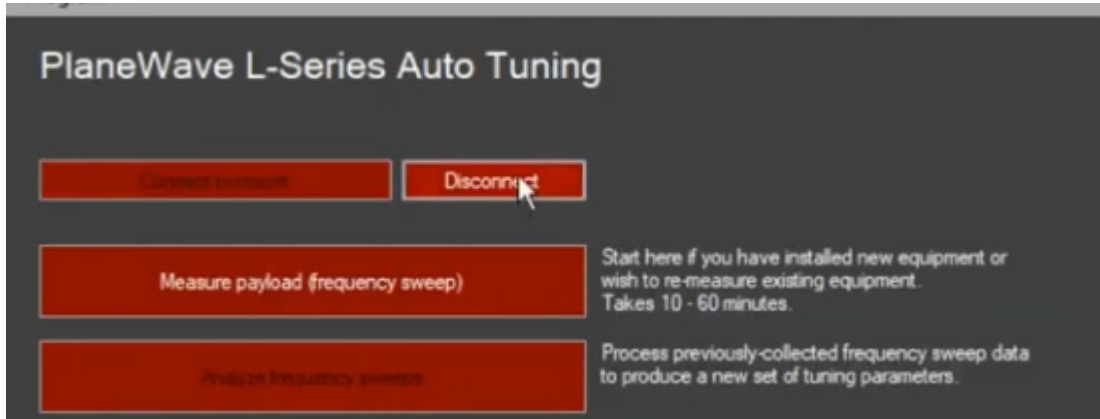

16. Issue a few slews to targets within PWI4 and watch the tracking graph to ensure the motors are tracking smoothly as seen below. If tracking is smooth you can proceed to building a pointing model and operating your system! If you notice oscillations in the tracking, please recheck balance of your system and then run AutoTuner again, except this time use the Thorough Scan Density.

