



**BLADE**

**GPS**

BASE PERFORMANCE  
SIMULATORS

THE ULTIMATE IN HOME SIMULATION





BASE PERFORMANCE  
SIMULATORS



BPS is one of the world's leading simulation companies. Based in the UK, their reputation has a global reach. With decades of experience developing cutting-edge simulators, the skills and expertise housed at BPS are unrivalled.

The team is led by factory Aston Martin driver and three-time Le Mans winner Darren Turner. Darren is a consultant to the Formula 1™ industry and has been developing simulators for over 23 years.

[BASEPERFORMANCE.NET](https://baseperformance.net)



# BLADE

Built on a specially-commissioned, rigid, powder-coated steel frame, this simulator boasts a BPS carbon, two-pedal box with electric fore/aft adjustment and a bespoke BPS carbon fibre race seat. Blade features the Precision Sim GPX Steering Wheel and runs a professional steering motor from Simucube; the Simucube 2 PRO provides 25nm of torque for the most realistic steering feel in simulation.

For sound and vision, Blade is supplied with a Cambridge Audio speaker system and Sennheiser headset plus a single 49" curved Samsung monitor with 120hz refresh rate, which creates a fully immersive driving experience.



# TECHNICAL SPECIFICATION

- **BODY WORK:**  
Bespoke powder-coated steel frame
- **SEAT:**  
Bespoke BPS Blade carbon seat
- **PEDAL BOX:**  
BPS designed electronically adjustable carbon fibre two-pedal box with 200mm of travel, electric actuator and all mechanics hidden by carbon fibre footplate.
- **STEERING MOTOR:**  
Simucube 2 PRO steering motor providing exceptional torque response & accurate feedback.
- **STEERING WHEEL:**  
Precision SIM GPX steering wheel with paddle shift and clutch. Boasting 9 rotatory dials, 12 push buttons, full colour LCD display and dual-clutch paddles with an adjustable bite point.

**D-BOX**





# TECHNICAL SPECIFICATION

- **VISION:**  
Samsung 49" curved ultra-wide gaming monitor
- **SOUND:**  
2 x Cambridge Audio speaker system  
Sennheiser PC373D 7.1 headset
- **COMPUTER HARDWARE**  
High specification gaming computer
- **SOFTWARE COMPATIBILITY:**  
Supplied with Assetto Corsa \*users are able to run on other platforms, inc IRacing

**STARTING FROM £18,958**

Includes: Installation & delivery (UK ONLY) & 12 months warranty\* (telephone support)



# OPTIONAL EXTRAS

- ▶ SOFTWARE:  
Assetto Corsa PRO software with updated BPS track and car models - £2,575 + VAT
- ▶ VISION:  
Triple screen 32" gaming monitors with stand - £995 + VAT
- ▶ 3 DOF MOVEMENT:  
D-Box Gen3 4250i four point actuator kit - £9,999 + VAT
- ▶ PERFORMANCE MONITORING:  
VBOX Sim Pack with capture card - £995 + VAT
- ▶ WARRANTY:  
Extended two year warranty - £955 + VAT
- ▶ CLUTCH & PEDAL BOX:  
Manual clutch with three foot pedal box system - £800 + VAT

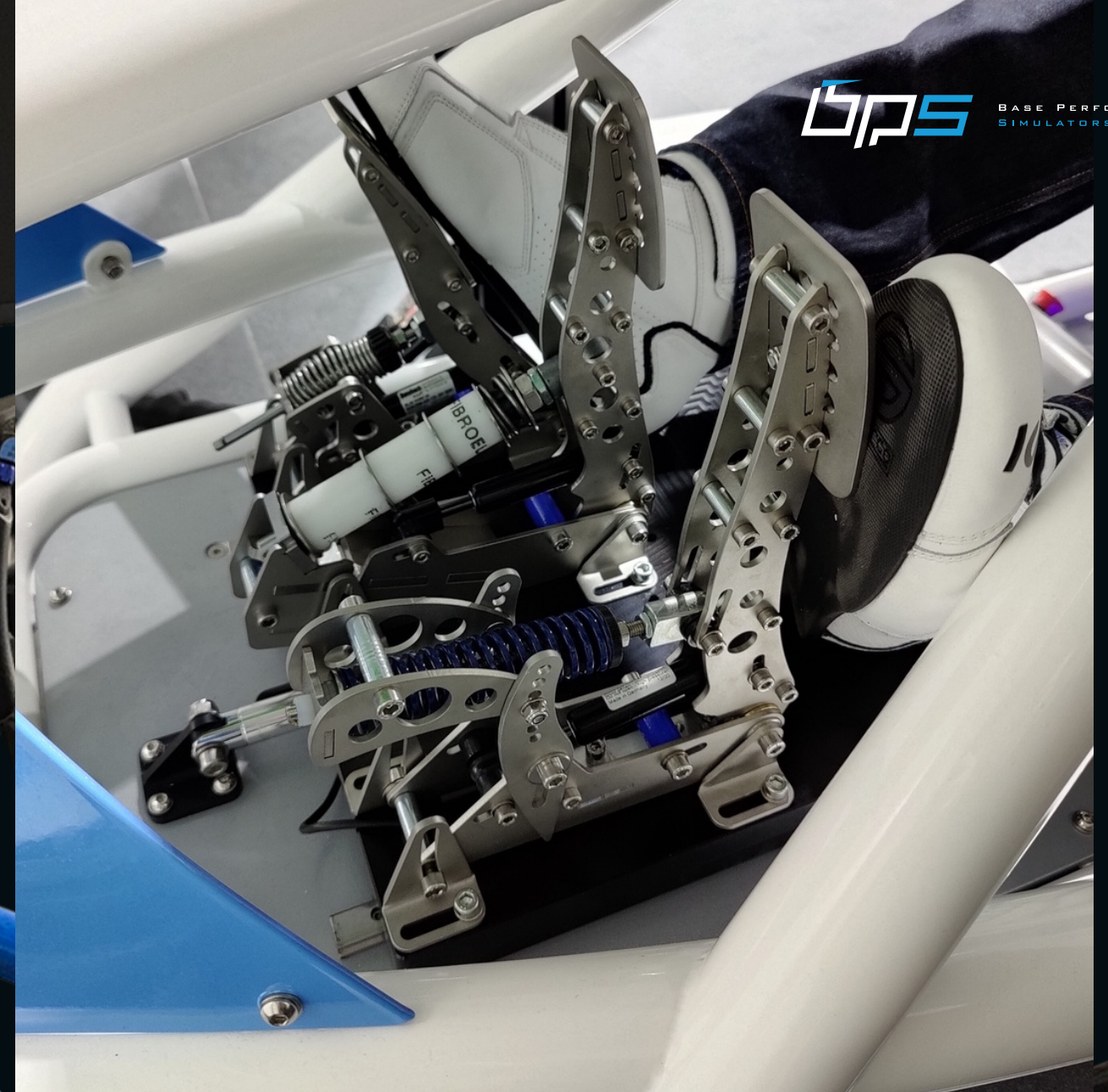



# BESPOKE LIVERY

- ▶ ORIGINAL:  
The Blade comes, as standard, in a powder coated black finish
- ▶ COLOUR UPGRADE:  
Match your blade to your racing colours.  
The blade is also available in a variety of colours  
Extra: £200 + VAT
- ▶ BESPOKE:  
Looking to elevate your sim further?  
The BPS design team can create a custom livery for a truly bespoke simulator - quoted upon request.

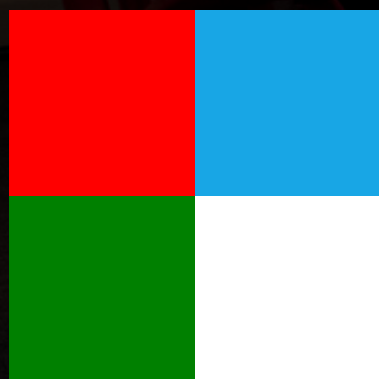



# THE BRABHAM COLLECTION

Celebrating three defining eras in the history of the Brabham name in Formula 1.TM

## THE BT19 -

The BT19 made Sir Jack Brabham the first and so far only driver to win the world championship in a car of his own construction. The BT19 sim reflects the green and gold colour scheme of this pioneering era.

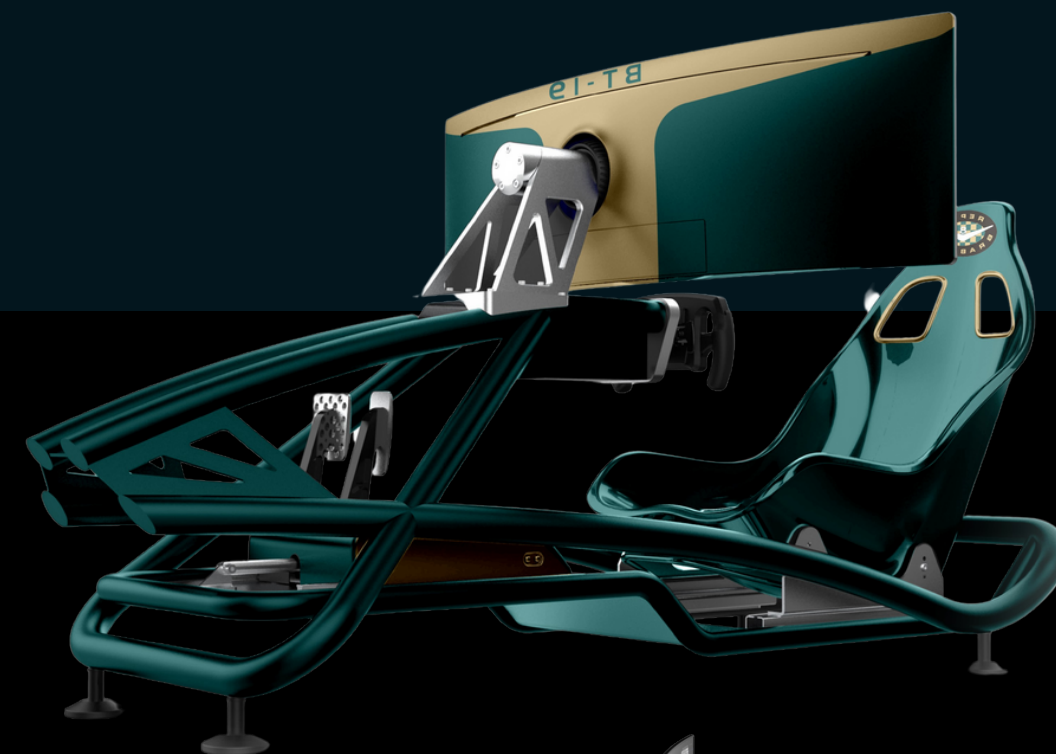

## THE BT46B -

Known as 'The Fan Car' The BT46B was introduced at the 1978 Swedish Grand Prix as a counter to the dominant ground-effect Lotus 79. The BT46B sim brings the red, white, and blue of this iconic car back to life.

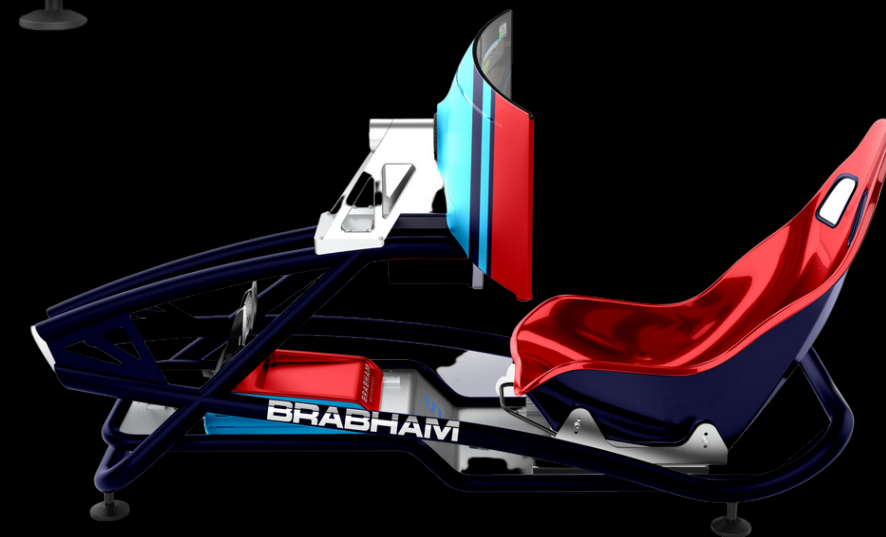

## THE BT52 -

Designed for the 1983 F1 season and took Nelson Piquet to his second world championship title at the height of Formula 1's power-hungry turbo years. The distinctive blue and white livery sets will make this sim the centrepiece of any area.

£20,825.00 + VAT





# DIMENSIONS

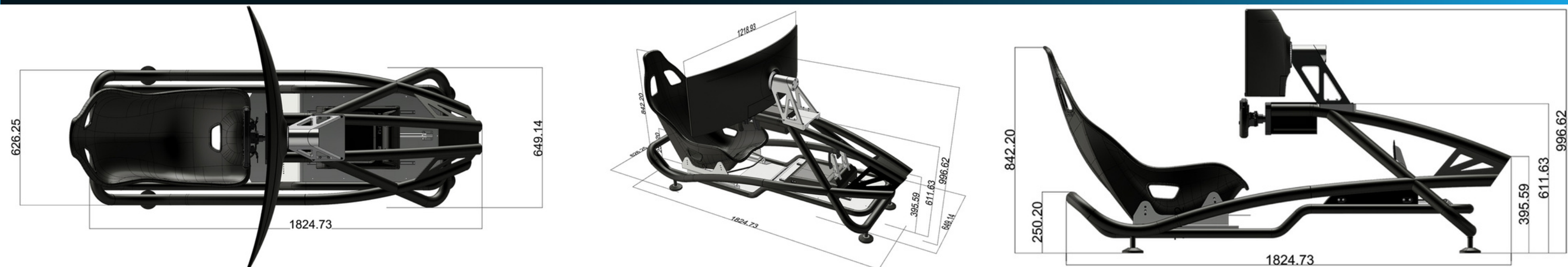

“The Blade’s pedal system comes the closest to the best bespoke F1 simulators I’ve driven and by far the most realistic home sim set up out there in terms of feel, quality and adjustability.”

Anthony Davidson: Development driver for the Mercedes AMG Petronas F1 Team



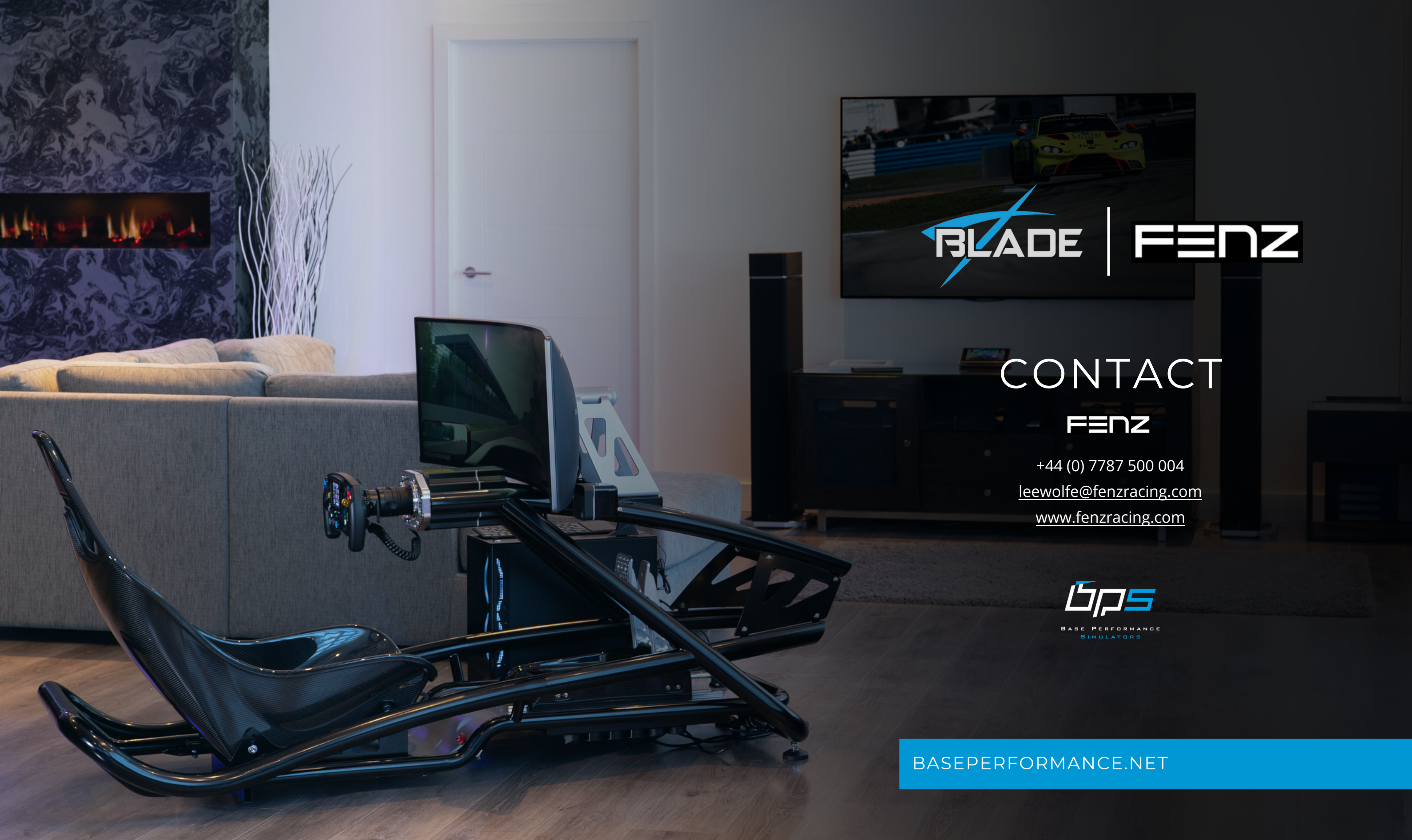

**BLADE | FENZ**

# CONTACT

**FENZ**

+44 (0) 7787 500 004

[leewolf@fenzracing.com](mailto:leewolf@fenzracing.com)

[www.fenzracing.com](http://www.fenzracing.com)



BASE PERFORMANCE  
SIMULATORS

[BASEPERFORMANCE.NET](http://BASEPERFORMANCE.NET)