

# INSTRUCTION MANUAL

## COLLAPSIBLE DOBSONIANS

200mm/1200mm (8")  
254mm/1200mm (10")  
305mm/1500mm (12")  
355mm/1650mm (14")  
400mm/1800mm (16")

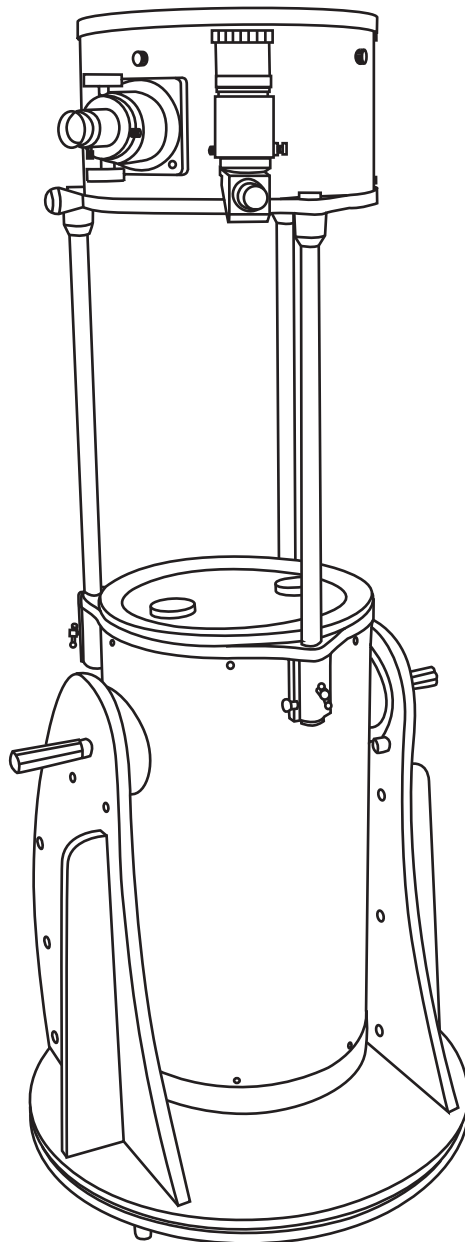

# TABLE OF CONTENTS

<b>Assembling Your Telescope</b> .....	<b>3</b>
Parts List (8" and 10") .....	3
Base Assembly (8" and 10") .....	4
Parts List (12") .....	5
Base Assembly (12") .....	6
Parts List (14" & 16") .....	8
Base Assembly (14" & 16") .....	9
Optical Tube Assembly (8", 10", 12", 14" and 16") .....	10
<b>Operating Your Telescope</b> .....	<b>11</b>
Aligning the Finderscope .....	11
Focusing .....	11
Using the optional Barlow Lens .....	11
Using the Tension Control Handle .....	12
Pointing the Dobsonian .....	12
Calculating the Magnification (power) .....	13
Calculating the Field of View .....	13
Calculating the Exit Pupil .....	13
<b>Observing the Sky</b> .....	<b>14</b>
Sky Conditions .....	14
Selecting an Observing Site .....	14
Choosing the Best Time to Observe .....	14
Cooling the Telescope .....	14
Adopting Your Eyes .....	14
<b>Proper Care for Your Telescope</b> .....	<b>15</b>
Collimation .....	16
Cleaning Your Telescope .....	17

## **B**efore you begin

This instruction manual is applicable to all the models listed on the cover. Read the entire manual carefully before beginning. Your telescope should be assembled during daylight hours. Choose a large, open area to work to allow room for all parts to be unpacked.

## **C**autions!

NEVER USE YOUR TELESCOPE TO LOOK DIRECTLY AT THE SUN. PERMANENT EYE DAMAGE WILL RESULT. USE A PROPER SOLAR FILTER FOR VIEWING THE SUN. WHEN OBSERVING THE SUN, PLACE A DUST CAP OVER YOUR FINDERSCOPE TO PROTECT IT FROM EXPOSURE. NEVER USE AN EYEPIECE-TYPE SOLAR FILTER AND NEVER USE YOUR TELESCOPE TO PROJECT SUNLIGHT ONTO ANOTHER SURFACE, THE INTERNAL HEAT BUILD-UP WILL DAMAGE THE TELESCOPE OPTICAL ELEMENTS.

# PARTS LIST (8" and 10")

## 1. Base (Part 1)

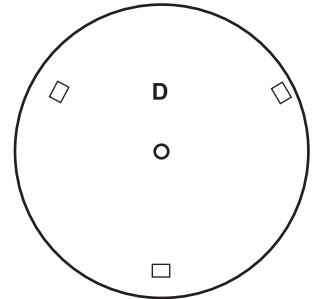
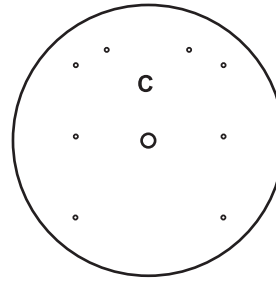
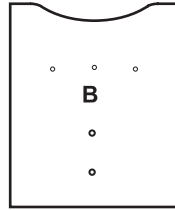
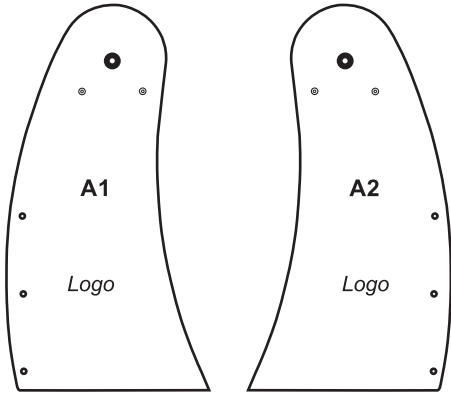

**Package 1** (14 screws)

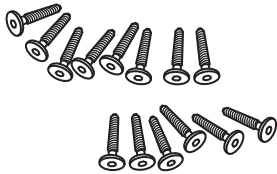

**Package 2** (1 tube, 1 bolt, 2 washers, 1 nut, 1 Teflon pad)

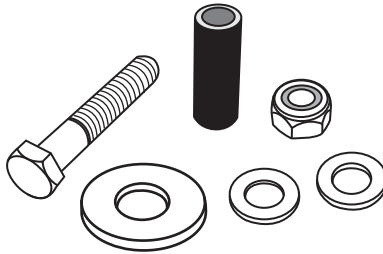

**Package 3** (1 accessory tray, 3 screws)

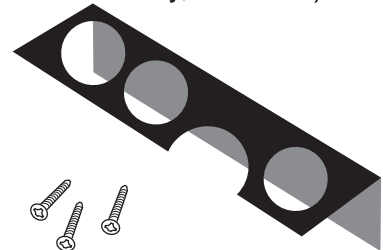

**Package 4**  
(1 handle, 2 screws)

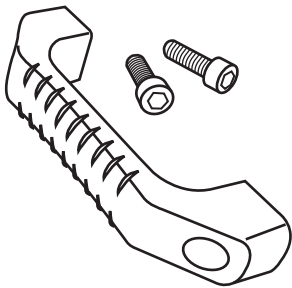

**Package 5** ( 1 Phillips screwdriver, 2 Alan wrenches, 2 wrenches)

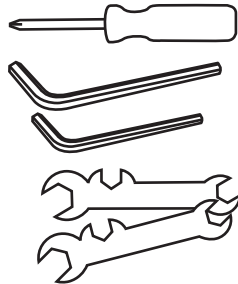

**Package 6**  
(4 cylindrical saddle side bearings, 4 screws)

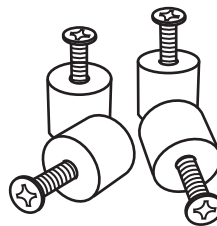

**Package 7**  
(1 handle, 1 tension control handle)

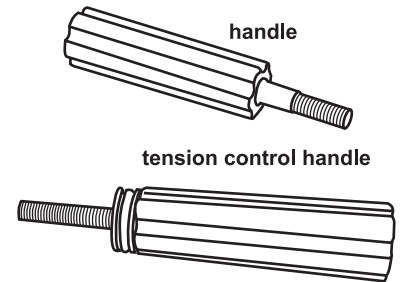

## 2. OTA (Optical Tube Assembly) (Part 2)

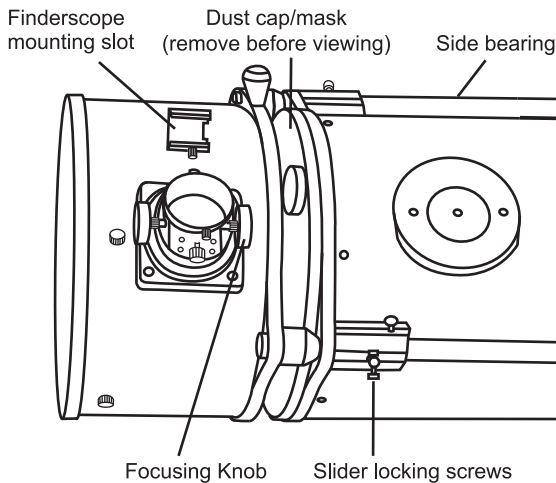

**Finderscope and bracket**



(Straight through finderscope shown here)

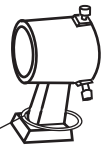

Rubber O Ring  
(Remove before installation)

Two eyepieces    2" Eyepieces holder    1.25" Eyepiece adapter



\*Contact your dealers for details on accessories included

# BASE ASSEMBLY (8" and 10")

1. Connect the board B to the board A1 and A2. Make sure the logos on the board A1 and A2 are on the outside. The side of the board B with three small holes should be facing the front.

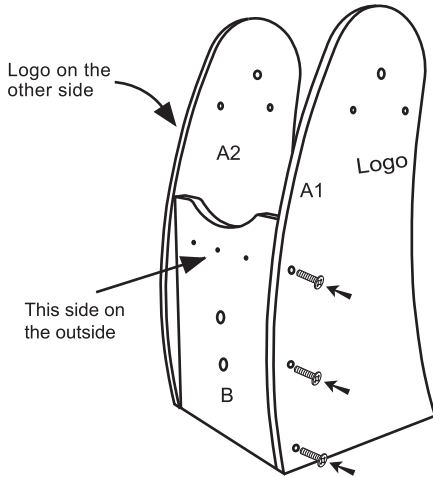

2. Connect the assembly to the round board C.

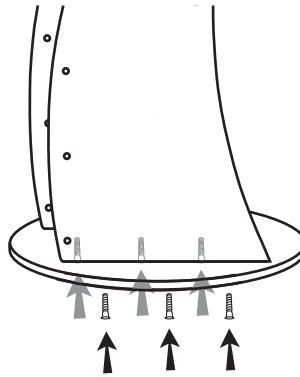

3. Attach the three feet to board D

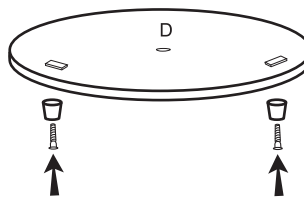

4. Place the teflon pad in between the assembly from step 2 and the board D. Insert the black tube from package 2 through the holes in the centre of all the above.

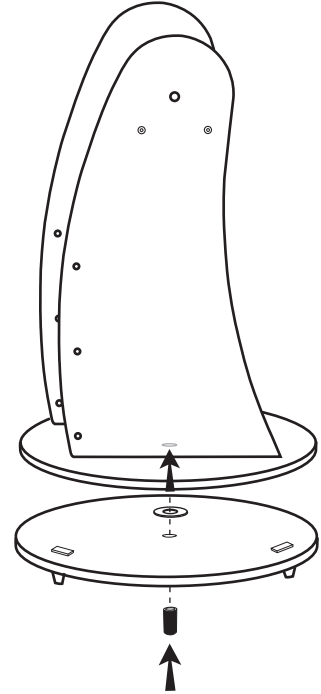

5. Take the bolt from package 2 with a washer on it and insert it through the tube. Secure with second washer and the nut using the two wrench provided. Do not over-tighten the bolt. This will prevent the mount base from freely spinning on the bottom round board.

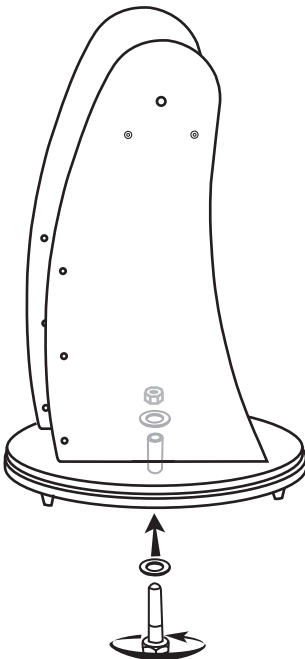

6. Position the accessory tray over the 3 holes in the board B and secure with the 3 small screws provided.

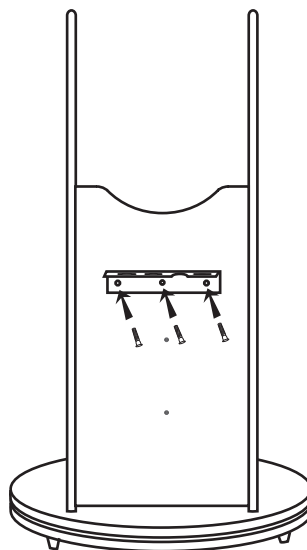

7. Attach the handle from package 4 to the board B with the two screws and the Allen wrench from package 5.

8. Unassemble the cylindrical saddle side bearings and the screws from package 5. Attach the cylindrical saddle side bearings to the inside of board A1 and A2 using the screws provided.

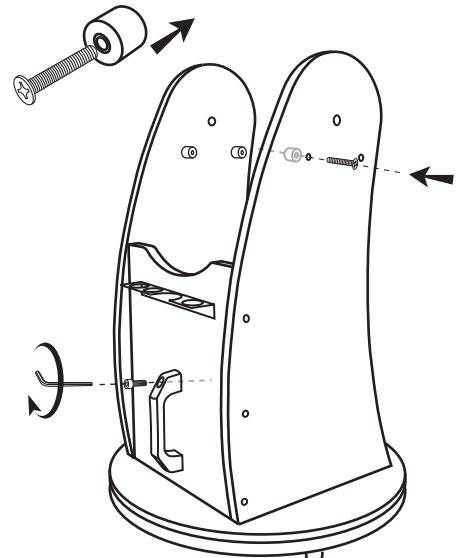



# PARTS LIST (12")

## 1. Base (Part 1)

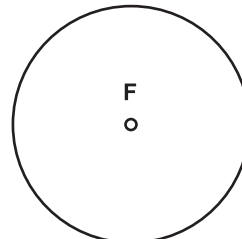
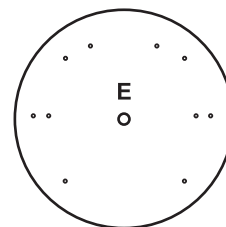
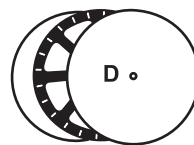
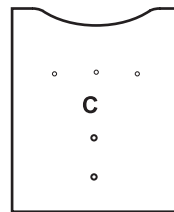
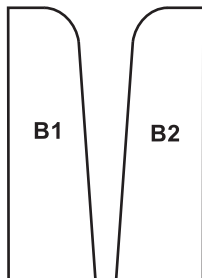
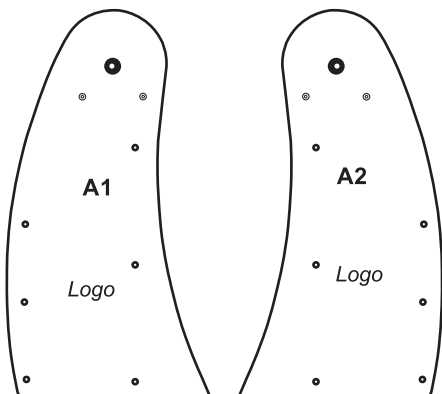

**Package 1&2** (total 24 screws)

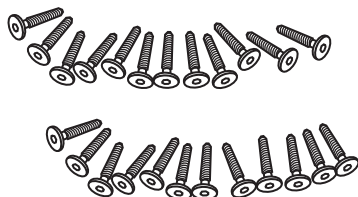

**Package 3** (1 tube, 1 bolt, 2 washers, 1 nut)

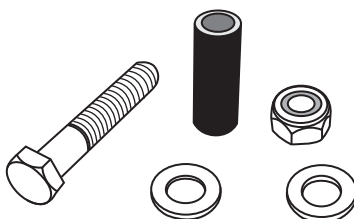

**Package 4** (1 accessory tray, 3 screws)

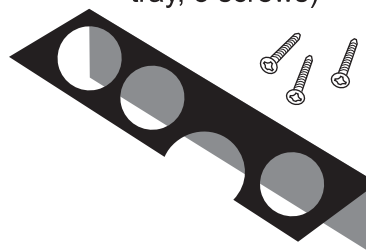

**Package 5**  
(1 handle, 2 screws)

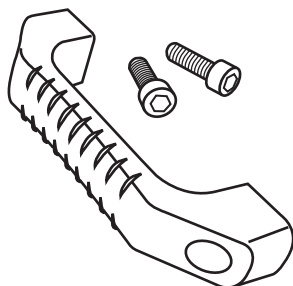

**Package 6** (1 Phillips screwdriver, 2 Alan wrenches, 2 wrenches)

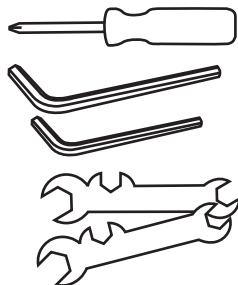

**Package 7**  
(4 cylindrical saddle side bearings, 4 screws)

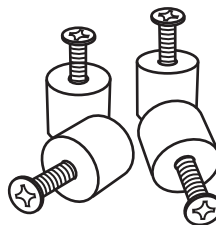

**Package 8**  
(1 handle, 1 tension control handle)

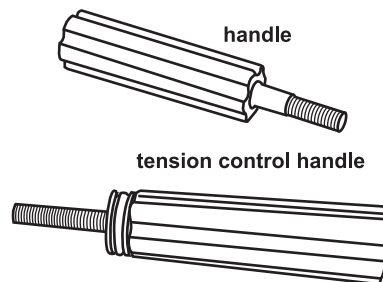

## 2. OTA (Optical Tube Assembly) (Part 2)

Finderscope mounting slot  
Dust cap/mask (remove before viewing)  
Side bearing

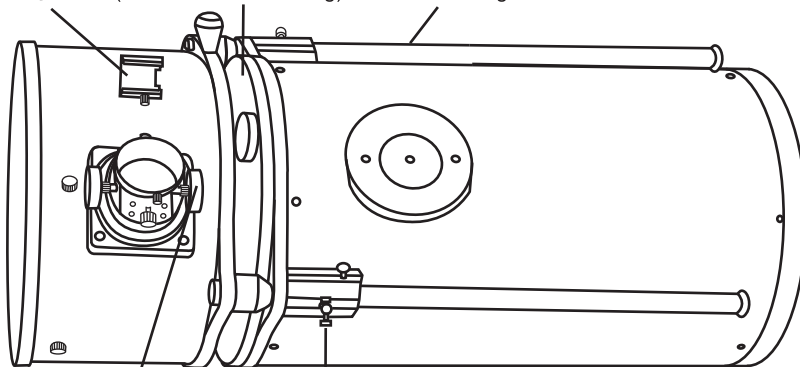

Focusing Knob  
Slider locking screws

Finderscope and bracket



(Straight through finderscope shown here)



Rubber O Ring  
(Remove before installation)

Two eyepieces  
2" Eyepieces holder  
1.25" Eyepiece adapter

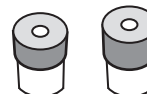

# B BASE ASSEMBLY 12"

1. Connect the board C to the board A1 and A2. Make sure the logos on the board A1 and A2 are on the outside. The side of the board B with three small holes should be facing the front.

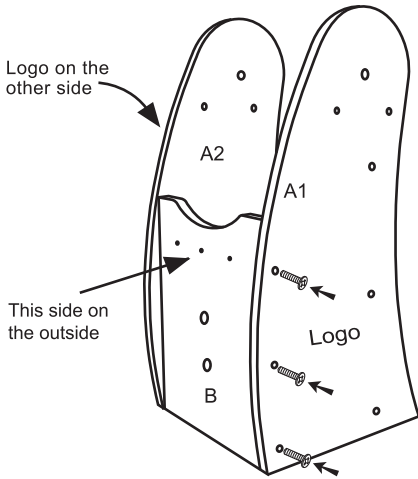

2. Connect the assembly to the round board E.

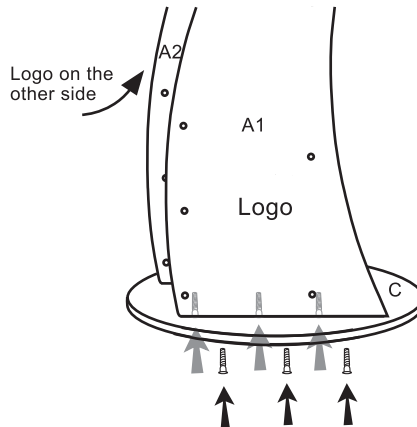

3. Connect the board B1 and B2 as shown in the drawing below.

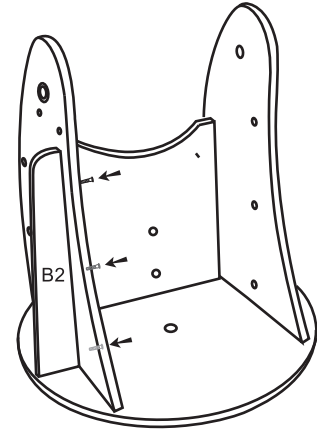

4. Layer the bearings together as seen in the drawing below.

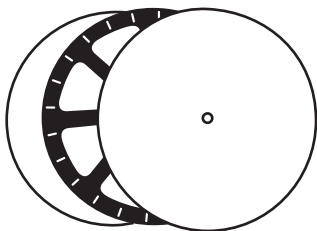

5. Attach the round plastic feet to board F. Place the bearings in between the assembly from step 2 and the board F. Insert the black tube from package 3 through the holes in the centre of all the above.

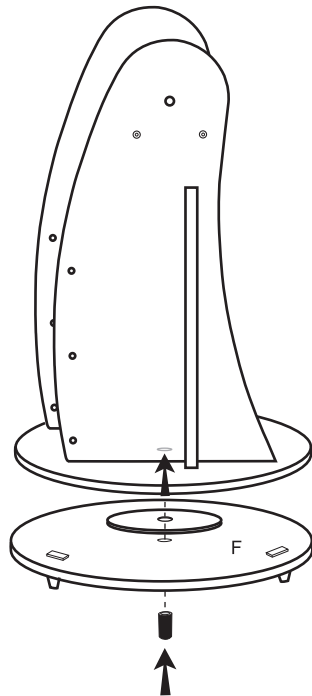

6. Take the bolt from package 3 with a washer on it and insert it through the tube. Secure with second washer and the nut using the two wrench provided. Do not over-tighten the bolt. This will prevent the mount base from freely spinning on the bottom round board.

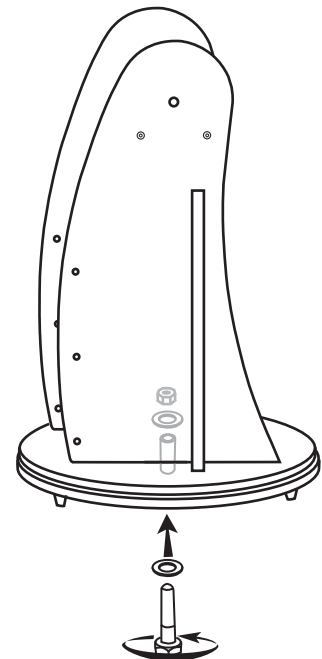

# B BASE ASSEMBLY (12")

7. Position the accessory tray over the 3 holes in the board C and secure with the 3 small screws provided.

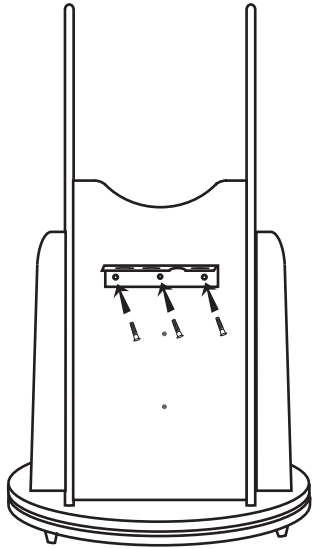

8. Attach the handle from package 5 to the board C with the two screws and the Allen wrench from package 6.

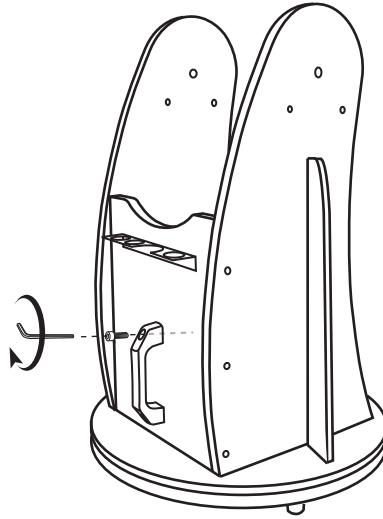

9. Unassemble the cylindrical saddle side bearings and the screws from package 7. Attach the cylindrical saddle side bearings to the inside of board A1 and A2 using the screws provided. Cover all visible small screws with the screw caps provided.

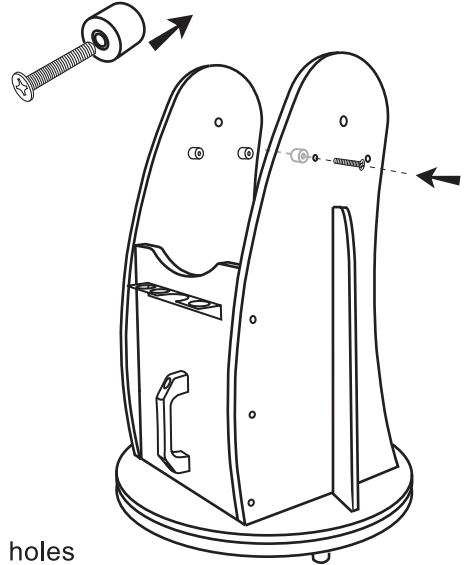

10. Place the optical tube between the board A1 and A2. Make sure that the side bearings of the tube are rested on the 4 cylindrical saddle side bearings.

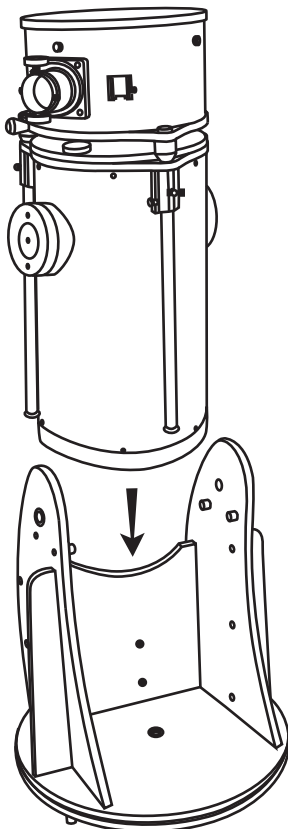

11. Install the handles into the holes on the board A1 and A2. Do not over tighten the handles. Make sure that the tension control handle is installed on the same side as the focuser for your convenience.

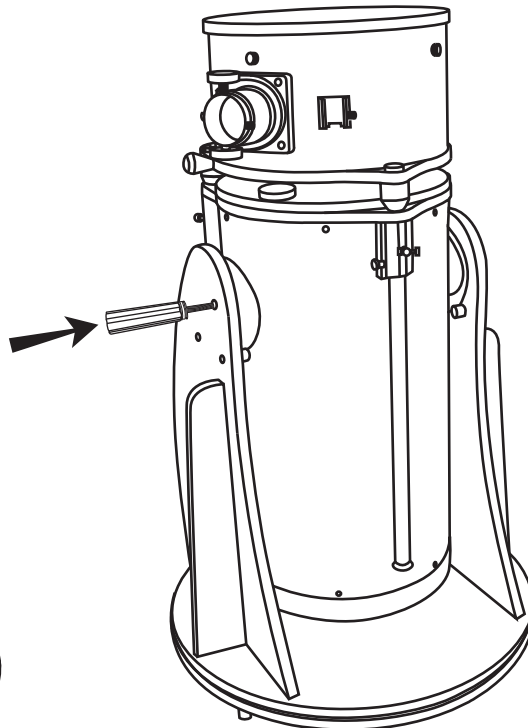

# PARTS LIST (14" & 16")

## 1. Base (Part 1)

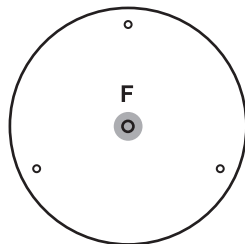
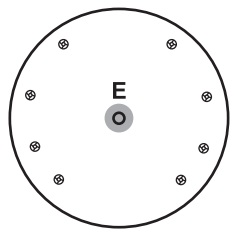
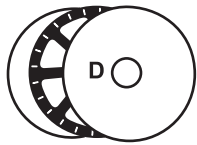
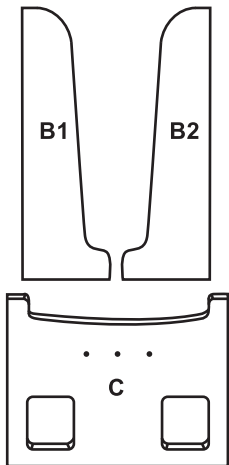
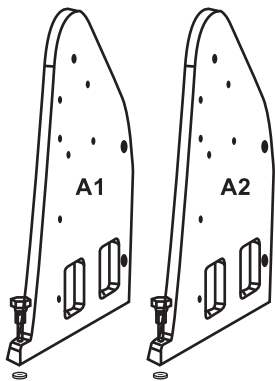

**Package 1** (6 screws)



**Package 2**  
(14": 12 base screws,  
16": 14 base screws)



**Package 3** 14" & (16")  
(1 washer pushing tool,  
12 (14) fastening bolts,  
12 (14) washers)

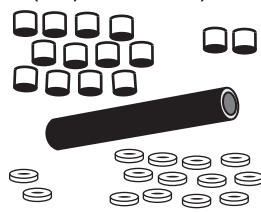

**Package 4** (1 accessory  
tray, 3 screws)

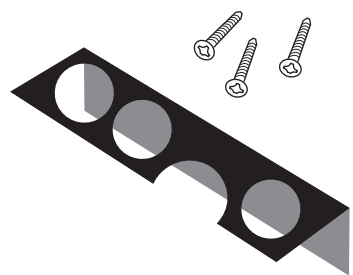

**Package 5** (2 handles,  
4 screws)

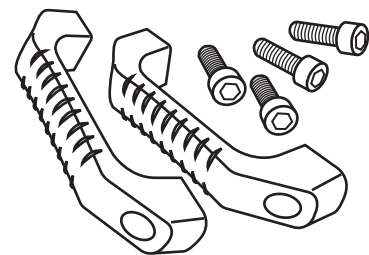

**Package 6** ( 1 Phillips  
screwdriver, 2 Alan  
wrenches, 2 wrenches,  
1 bolt, 2 washers, 1 nut)

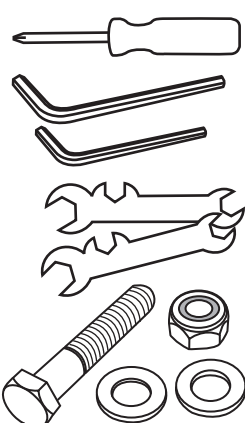

**Package 8**  
(1 handle, 1 tension  
control handle)

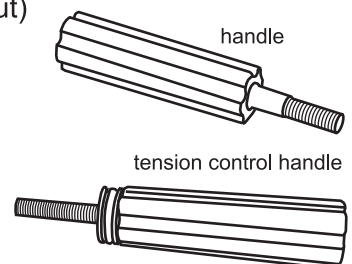

**Package 9** (1 bolt  
protection tube, 1 large  
white plastic washer)

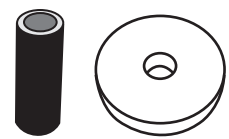

**Package 7** (4 cylindrical  
saddle side bearings,  
4 screws)

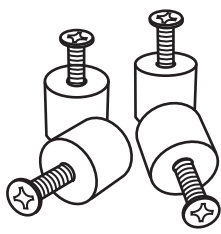

**Package 10** (3 feet)

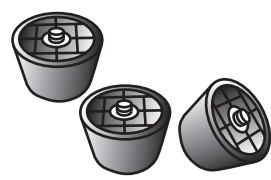

## 2. OTA (Optical Tube Assembly) (Part 2)

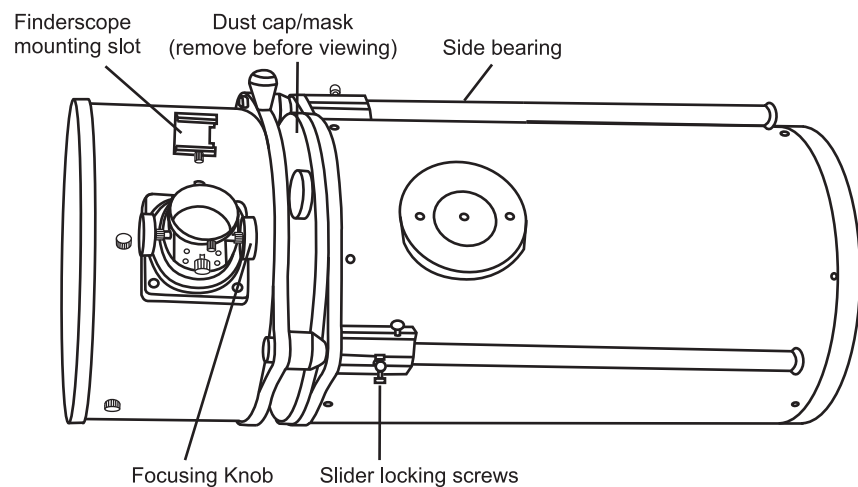

**Finderscope and bracket**

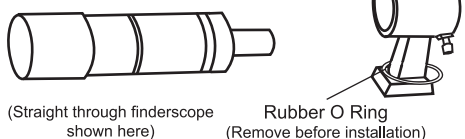

**2 eyepieces**

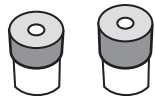

**2" Eyepieces holder**



**1.25" Eyepiece adapter**



**2 black handles**



# BASE ASSEMBLY 14" and 16"

## Round base assembly setup

1. Push the Countersunk head Phillips screws through the board F from its top side to bottom side. Attach the 3 feet in package 10 on bottom.

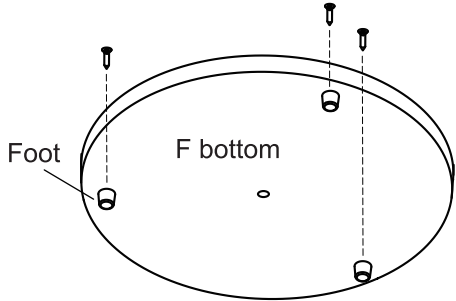

2. Stack the bearings together.

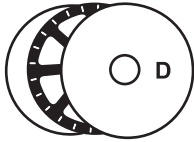

3. Place the bearings D and the large white plastic washer in between the board E and the board F. Insert the short black protection tube through the holes in the centre.

Take the bolt with one washer on it and insert them through the tube from the bottom of the board F. Secure with the second washer and the nut on top of the board E with the 2 wrenches provided in package 6.

Do not over-tighten the bolt. This will prevent the mount base from freely spinning on the bottom round board.

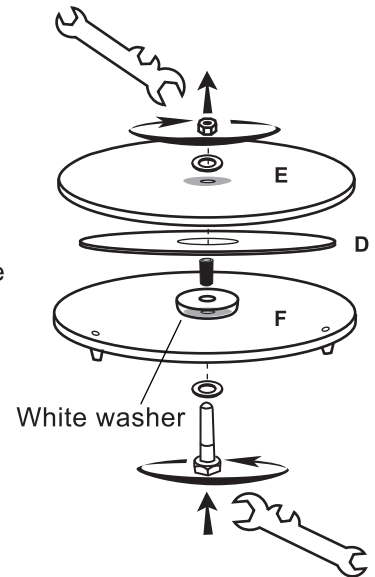

## Side and front panel setup

### Left and right side panels

Connect the board B to the board A with the 3 screws provided in package 1. Install the handle with the 2 screws provided in package 5.

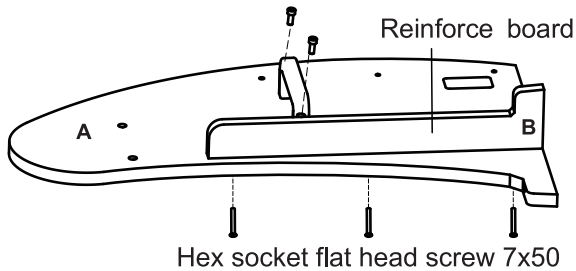

### Front panel

Place eyepiece holder on the board C with the 3 screws in package 4.

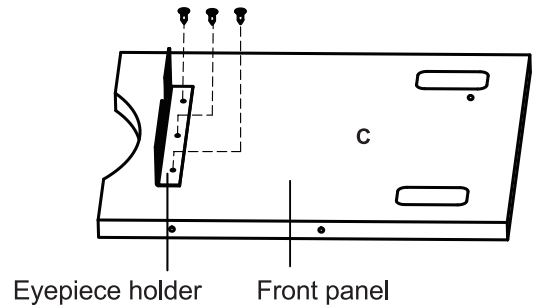

## Mount setup

Secure the base screws with the fastening bolts and washers on the side and front panels according to the diagram.

Use the long black washer pushing tool in package 3 to help pushing the fastening bolts and the washers to the position.

Assemble the side and front panels on the base board by tightening the base screws.

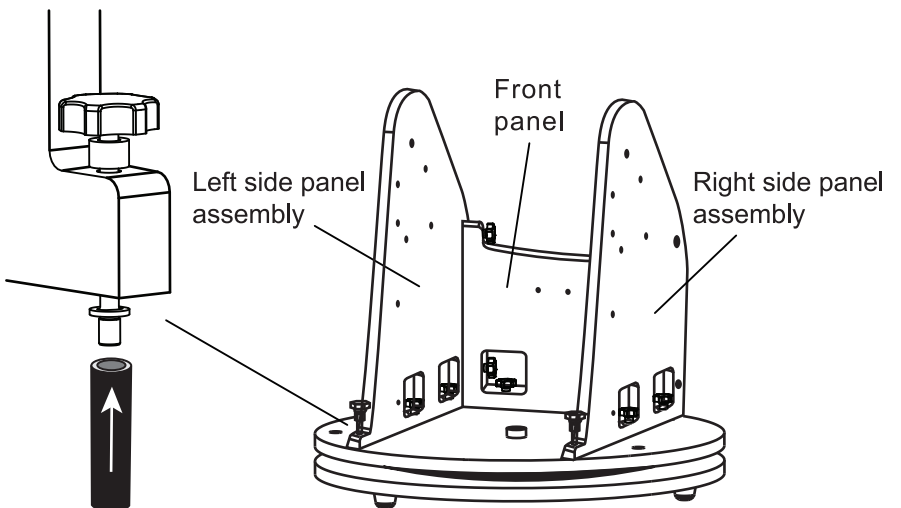

# OPTICAL TUBE ASSEMBLY (8", 10", 12", 14" and 16")

1. Place the optical tube between the board A1 and A2. Make sure that the side bearings of the tube are rested on the 4 cylindrical saddle side bearings.

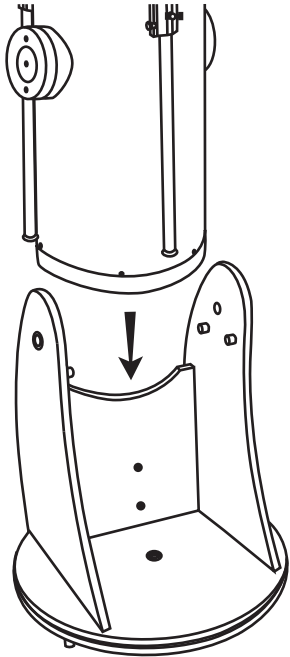

2. Install the handles into the holes on the board A1 and A2. Do not over tighten the handles. Make sure that the tension control handle is installed on the same side as the focuser for your convenience.

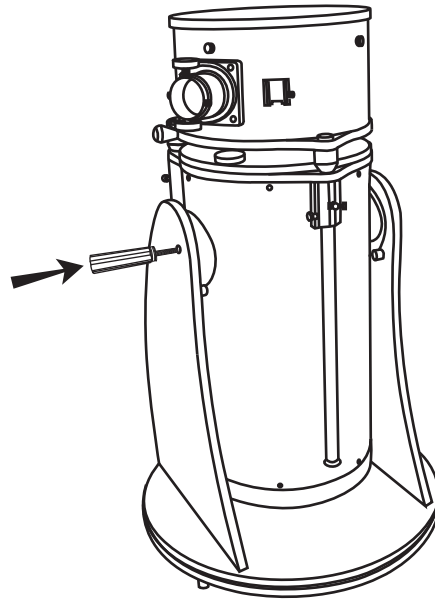

3. Locate the finderscope bracket and carefully remove the rubber-o-ring from it. Position the o-ring into groove on the finderscope tube.

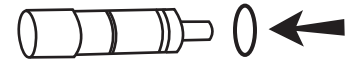

(Straight through finderscope shown here)

4. Slide the finderscope bracket into the mounting slot and tighten the screw to hold the bracket in place.

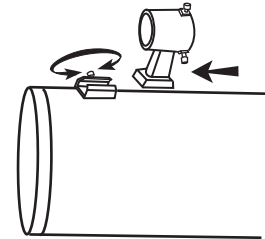

5. Loosen the two adjusting screws on the bracket. Position the finderscope into its bracket by sliding it backwards until the rubber o-ring seats.

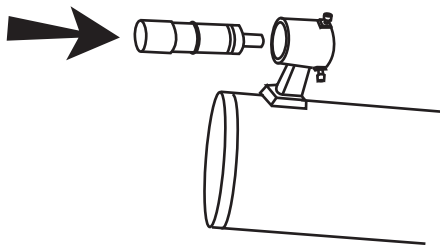

7. In order to use the telescope you need to extend the length of the telescope tube to its fullest. To extend the telescope tube, unlock the 3 locking screws on the bottom tube. Hold on to the knob on the top tube and carefully pull the top tube up until it clicks in place. Make sure to retighten the locking screws.

Remove the dust cap on the bottom tube before viewing.

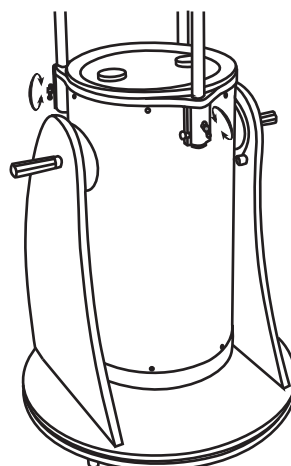

8. To transport the telescope, unlock the three locking. Hold on to the black handles on the upper tube and carefully apply pressure until the upper tube starts to slide down. Slide the upper tube down carefully. Do not let go of the handle until the upper tube is safely rested on the bottom tube. Be sure to tighten the three locking screws to keep the tubes securely in place.

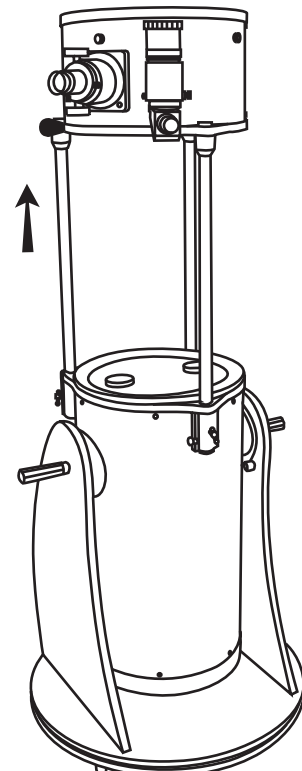

6. Remove the black plastic end-cap. Loosen the thumbscrews on the end of the focus tube if the end-cap can not be removed. Insert the desired eyepiece and lightly tighten the thumbscrews to hold the eyepiece in place.

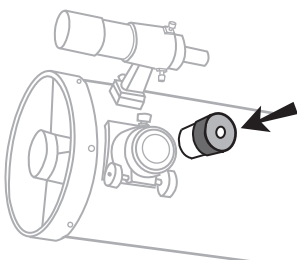



# OPERATING YOUR TELESCOPE

## Aligning the Finderscope

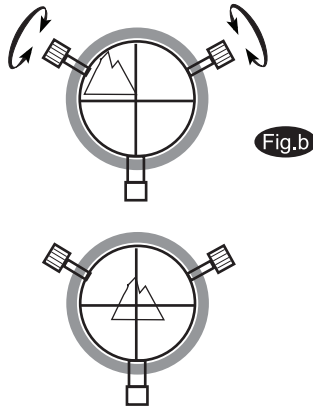
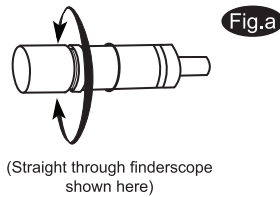

These fixed magnification scopes mounted on the optical tube are very useful accessories. When they are correctly aligned with the telescope, objects can be quickly located and brought to the centre of the field. Alignment is best done outdoors in day light when it's easier to locate objects. If it is necessary to refocus your finderscope, sight on an object that is at least 500 yards (metres) away. Loosen the locking ring by unscrewing it back towards the bracket. The front lens holder can now be turned in and out to focus. When focus is reached, lock it in position with the locking ring (Fig.a).

1. Choose a distant object that is at least 500 yards away and point the main telescope at it. Adjust the telescope so that the object is in the centre of the view in your eyepiece.
2. Check the finderscope to see if the object centred in the main telescope view is centred on the crosshairs.
3. Use the two small alignment screws to centre the finderscope crosshairs on the object. The screws work in opposition to a spring-loaded knob (Fig.b).

## Focusing

Slowly turn the focus knobs (Fig.c), one way or the other, until the image in the eyepiece is sharp. The image usually has to be finely refocused over time, due to small variations caused by temperature changes, flexures, etc. This often happens with short focal ratio telescopes, particularly when they haven't yet reached outside temperature. Refocusing is almost always necessary when you change an eyepiece or add or remove a Barlow lens.

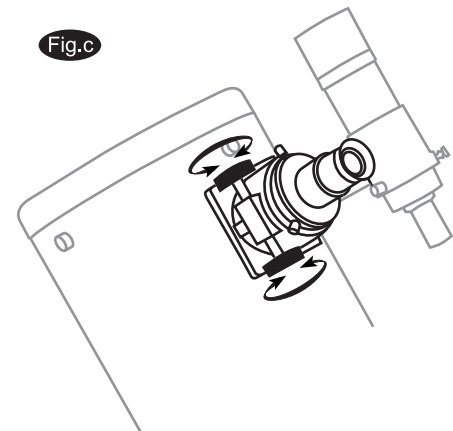

## Using the Barlow lens (optional)

A Barlow is a negative lens which increases the magnifying power of an eyepiece, while reducing the field of view. It expands the cone of the focussed light before it reaches the focal point, so that the telescope's focal length appears longer to the eyepiece. The Barlow should be inserted between the focuser and the eyepiece in your Dobsonian (Fig.d).

In addition to increasing magnification, the benefits of using a Barlow lens include improved eye relief, and reduced spherical aberration in the eyepiece. For this reason, a Barlow plus a lens often outperform a single lens producing the same magnification. However, its greatest value may be that a Barlow can potentially double the number of eyepiece in your collection.

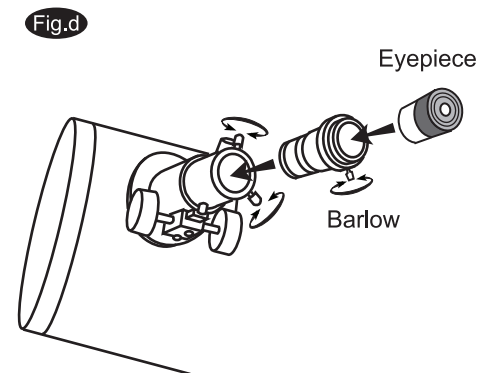

## Using the Tension Control Handle

Loosen or tighten the tension control handle to add just enough friction to allow the tube to move easily when nudged but to stay in position when not. It may be necessary to re-adjust the tension control handle when accessories are added to, or removed from, the tube. The tension control handle should be installed on the same side as the eyepiece for your convenience. Leave the handle on the other side slightly loose to allow full tension control for the tension control handle (Fig.e).

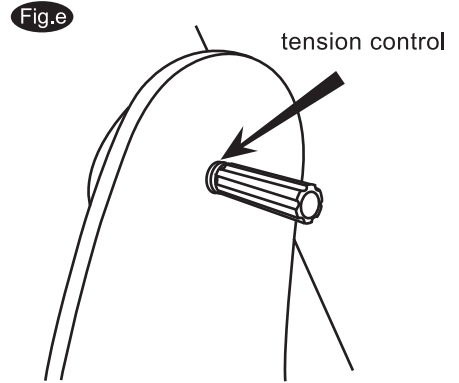

## Pointing the Dobsonian

Pointing an altitude-azimuth (alt-az) mounted telescope, such as a Dobsonian, is relatively easy. With the mount level, you can swivel the telescope around on a plane parallel to your horizon and then tilt it up and down from there (Fig.f). You can think of it as turning your telescope in azimuth until it is facing the horizon below a celestial object and then tilting it up to the object's altitude. However, the Earth rotates and therefore the stars are constantly moving, so to track with this mount you have to constantly nudge the optical tube in both azimuth and altitude to keep the object in the field.

In reference material for your local position, the altitude will be listed as  $\pm$ degrees (minutes, seconds) above or below your horizon. Azimuth may be listed by the cardinal compass points such as N, SW, ENE, etc., but it is usually listed in 360 degree (minutes, seconds) steps clockwise from North ( $0^\circ$ ), with East, South and West being  $90^\circ$ ,  $180^\circ$  and  $270^\circ$ , respectively (Fig.f).

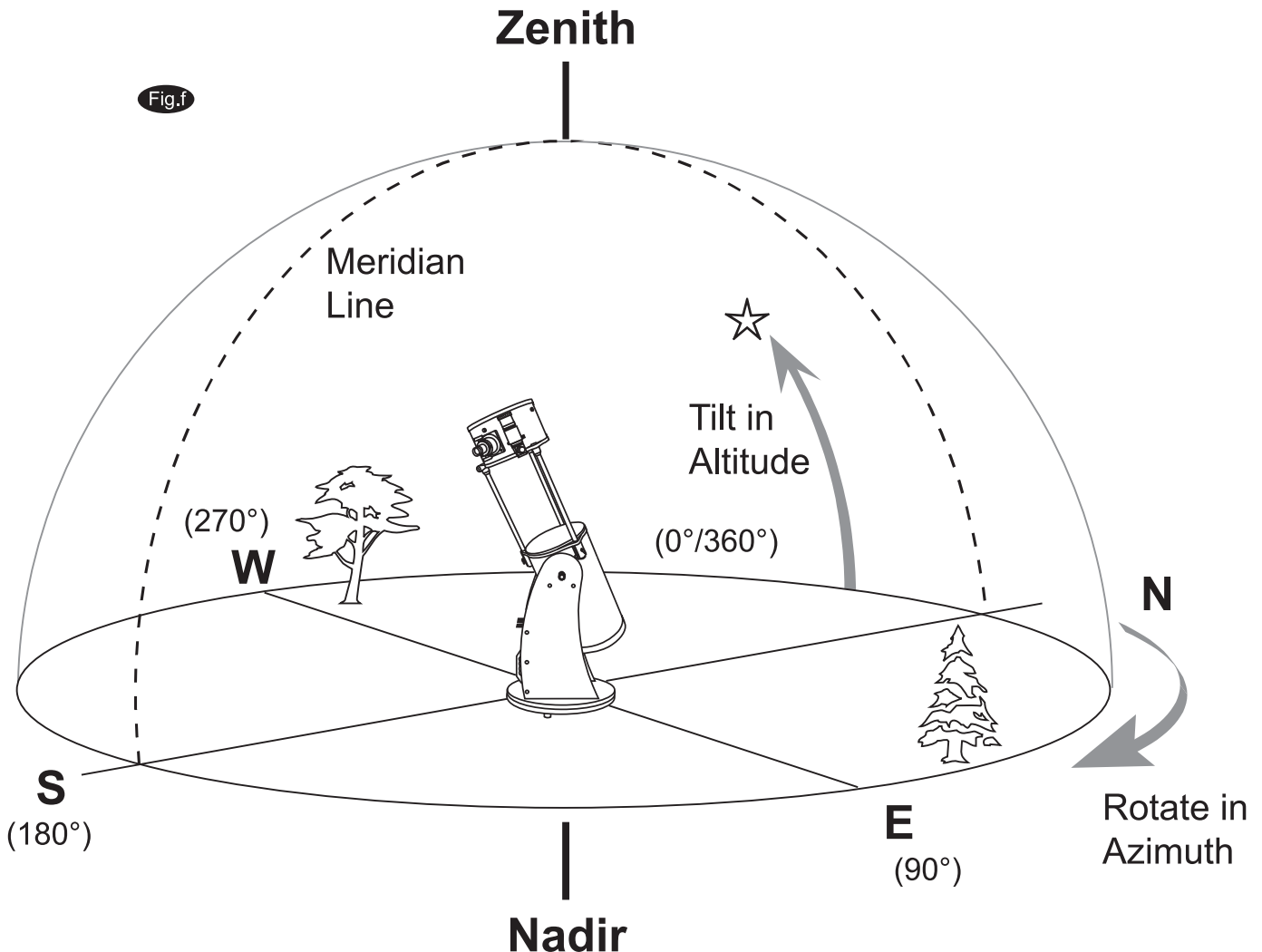



## Calculating the Magnification (Power)

The magnification produced by a telescope is determined by the focal length of the eyepiece that is used with it. To determine a magnification for your telescope, divide its focal length by the focal length of the eyepieces you are going to use. For example, a 10mm focal length eyepiece will give 80X magnification with an 800mm focal length telescope.

$$\text{magnification} = \frac{\text{Focal length of the telescope}}{\text{Focal length of the eyepiece}} = \frac{800\text{mm}}{10\text{mm}} = 80\text{X}$$

When you are looking at astronomical objects, you are looking through a column of air that reaches to the edge of space and that column seldom stays still. Similarly, when viewing over land you are often looking through heat waves radiating from the ground, house, buildings, etc. Your telescope may be able to give very high magnification but what you end up magnifying is all the turbulence between the telescope and the subject. A good rule of thumb is that the usable magnification of a telescope is about 2X per mm of aperture under good conditions.

## Calculating the Field of View

The size of the view that you see through your telescope is called the true (or actual) field of view and it is determined by the design of the eyepiece. Every eyepiece has a value, called the apparent field of view, which is supplied by the manufacturer. Field of view is usually measured in degrees and/or arc-minutes (there are 60 arc-minutes in a degree). The true field of view produced by your telescope is calculated by dividing the eyepiece's apparent field of view by the magnification that you previously calculated for the combination. Using the figures in the previous magnification example, if your 10mm eyepiece has an apparent field of view of 52 degrees, then the true field of view is 0.65 degrees or 39 arc-minutes.

$$\text{True Field of View} = \frac{\text{Apparent Field of View}}{\text{Magnification}} = \frac{52^\circ}{80\text{X}} = 0.65^\circ$$

To put this in perspective, the moon is about 0.5° or 30 arc-minutes in diameter, so this combination would be fine for viewing the whole moon with a little room to spare. Remember, too much magnification and too small a field of view can make it very hard to find things. It is usually best to start at a lower magnification with its wider field and then increase the magnification when you have found what you are looking for. First find the moon then look at the shadows in the craters!

## Calculating the Exit Pupil

The Exit Pupil is the diameter (in mm) of the narrowest point of the cone of light leaving your telescope. Knowing this value for a telescope-eyepiece combination tells you whether your eye is receiving all of the light that your primary lens or mirror is providing. The average person has a fully dilated pupil diameter of about 7mm. This value varies a bit from person to person, is less until your eyes become fully dark adapted and decreases as you get older. To determine an exit pupil, you divide the diameter of the primary of your telescope (in mm) by the magnification.

$$\text{Exit Pupil} = \frac{\text{Diameter of Primary mirror in mm}}{\text{Magnification}}$$

For example, a 200mm f/5 telescope with a 40mm eyepiece produces a magnification of 25x and an exit pupil of 8mm. This combination can probably be used by a young person but would not be of much value to a senior citizen. The same telescope used with a 32mm eyepiece gives a magnification of about 31x and an exit pupil of 6.4mm which should be fine for most dark adapted eyes. In contrast, a 200mm f/10 telescope with the 40mm eyepiece gives a magnification of 50x and an exit pupil of 4mm, which is fine for everyone.

# OBSERVING THE SKY

## Sky conditions

Sky conditions are usually defined by two atmospheric characteristics, seeing, or the steadiness of the air, and transparency, light scattering due to the amount of water vapour and particulate material in the air. When you observe the Moon and the planets, and they appear as though water is running over them, you probably have bad "seeing" because you are observing through turbulent air. In conditions of good "seeing", the stars appear steady, without twinkling, when you look at them with unassisted eyes (without a telescope). Ideal "transparency" is when the sky is inky black and the air is unpolluted.

## Selecting an observing site

Travel to the best site that is reasonably accessible. It should be away from city lights, and upwind from any source of air pollution. Always choose as high an elevation as possible; this will get you above some of the lights and pollution and will ensure that you aren't in any ground fog. Sometimes low fog banks help to block light pollution if you get above them. Try to have a dark, unobstructed view of the horizon, especially the southern horizon if you are in the Northern Hemisphere and vice versa. However, remember that the darkest sky is usually at the "Zenith", directly above your head. It is the shortest path through the atmosphere. Do not try to observe any object when the light path passes near any protrusion on the ground. Even extremely light winds can cause major air turbulence as they flow over the top of a building or wall. If you try to observe on any structure, or even a sidewalk, movements you make may cause the telescope to vibrate. Pavement and concrete can also radiate stored heat which will affect observing.

Observing through a window is not recommended because the window glass will distort images considerably. And an open window can be even worse, because warmer indoor air will escape out the window, causing turbulence which also affects images. Astronomy is an outdoor activity.

## Choosing the best time to observe

The best conditions will have still air, and obviously, a clear view of the sky. It is not necessary that the sky be cloud-free. Often broken cloud conditions provide excellent seeing. Do not view immediately after sunset. After the sun goes down, the Earth is still cooling, causing air turbulence. As the night goes on, not only will seeing improve, but air pollution and ground lights will often diminish. Some of the best observing time is often in the early morning hours. Objects are best observed as they cross the meridian, which is an imaginary line that runs through the Zenith, due North-South. This is the point at which objects reach their highest points in the sky. Observing at this time reduces bad atmospheric effects. When observing near the horizon, you look through lots of atmosphere, complete with turbulence, dust particles and increased light pollution.

## Cooling the telescope

Telescopes require at least 10 to 30 minutes to cool down to outside air temperature. This may take longer if there is a big difference between the temperature of the telescope and the outside air. This minimizes heat wave distortion inside telescope tube (tube currents). Allow a longer cooling time for larger optics. If you are using an equatorial mount, use this time for polar alignment.

## Adapting your eyes

Do not expose your eyes to anything except red light for 30 minutes prior to observing. This allows your pupils to expand to their maximum diameter and build up the levels of optical pigments, which are rapidly lost if exposed to bright light. It is important to observe with both eyes open. This avoids fatigue at the eyepiece. If you find this too distracting, cover the non-used eye with your hand or an eye patch. Use averted vision on faint objects: The center of your eye is the least sensitive to low light levels. When viewing a faint object, don't look directly at it. Instead, look slightly to the side, and the object will appear brighter.

# PROPER CARE FOR YOUR TELESCOPE

## Collimation

Collimation is the process of aligning the mirrors of your telescope so that they work in concert with each other to deliver properly focused light to your eyepiece. By observing out-of-focus star images, you can test whether your telescope's optics are aligned. Place a star in the centre of the field of view and move the focuser so that the image is slightly out of focus. If the seeing conditions are good, you will see a central circle of light (the Airy disc) surrounded by a number of diffraction rings. If the rings are symmetrical about the Airy disc, the telescope's optics are correctly collimated (Fig.g).

If you do not have a collimating tool, we suggest that you make a "collimating cap" out of a plastic 35mm film canister (black with gray lid). Drill or punch a small pinhole in the exact center of the lid and cut off the bottom of the canister. This device will keep your eye centered of the focuser tube. Insert the collimating cap into the focuser in place of a regular eyepiece.

Collimation is a painless process and works like this:

Pull off the lens cap which covers the front of the telescope and look down the optical tube. At the bottom you will see the primary mirror held in place by three clips 120° apart, and at the top the small oval secondary mirror held in a support and tilted 45° toward the focuser outside the tube wall (Fig.h).

The secondary mirror is aligned by adjusting the three smaller screws surrounding the central bolt. The primary mirror is adjusted by the three adjusting screws at the back of your scope. The three locking screws beside them serve to hold the mirror in place after collimation. (Fig.i)

### Aligning the Secondary Mirror

Point the telescope at a lit wall and insert the collimating cap into the focuser in place of a regular eyepiece. Look into the focuser through your collimating cap. You may have to twist the focus knob a few turns until the reflected image of the focuser is out of your view. Note: keep your eye against the back of the focus tube if collimating without a collimating cap. Ignore the reflected image of the collimating cap or your eye for now, instead look for the three clips holding the primary mirror in place. If you can't see them (Fig.j), it means that you will have to adjust the three bolts on the top of the secondary mirror holder, with possibly an Allen wrench or Phillip's screwdriver. You will have to alternately loosen one and then compensate for the slack by tightening the other two. Stop when you see all three mirror clips (Fig.k). Make sure that all three small alignment screws are tightened to secure the secondary mirror in place.

Fig.g



Correctly aligned

Needs collimation

Fig.h

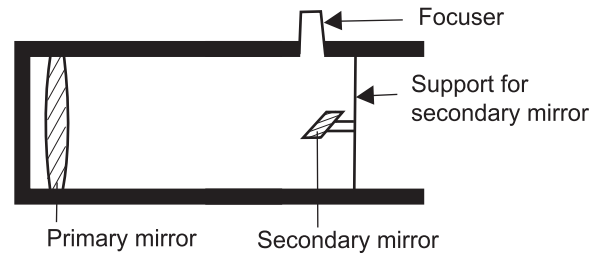

Fig.i

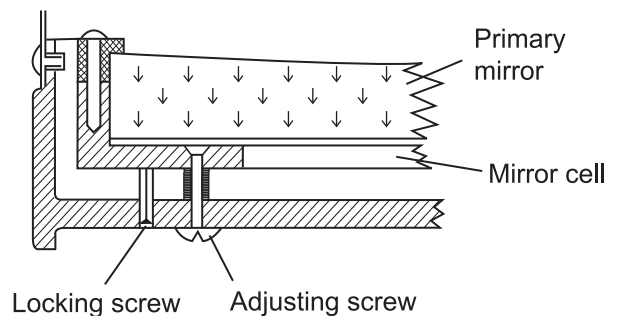

Fig.j

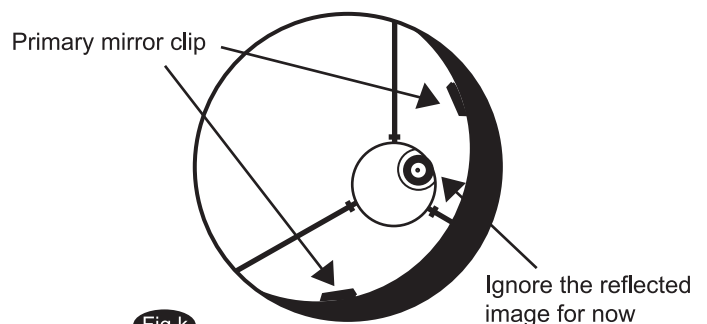
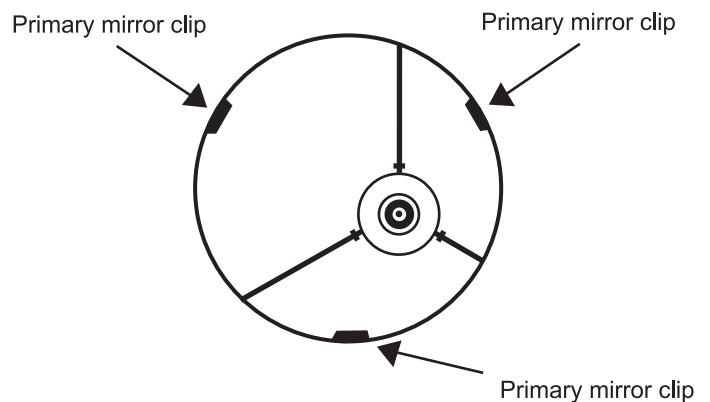

Fig.k



## Aligning the Primary Mirror

There are 3 hex bolts and 3 Phillip's head screws at the back of your telescope, for 150mm/1200mm and 200mm/1200mm the hex bolts are the locking screws and the Phillip's-head screws are the adjusting screws. For 254mm/1200 the flat headed screws are the adjusting screws and the thumbscrews are the locking screws (Fig.l). Use an Allen wrench to loosen the hex bolts by a few turns. Now run your hand around the front of your telescope keeping your eye to the focuser, you will see the reflected image of your hand. The idea here being to see which way the primary mirror is deflected, you do this by stopping at the point where the reflected image of the secondary mirror is closest to the primary mirrors' edge (Fig.m).

When you get to that point, stop and keep your hand there while looking at the back end of your telescope, is there an adjusting screw there? If there is you will want to loosen it (turn the screw to the left) to bring the mirror away from that point. If there isn't a adjusting screw there, then go across to the other side and tighten the adjusting screw on the other side. This will gradually bring the mirror into line until it looks like Fig.n. (It helps to have a friend to help for primary mirror collimation. Have your partner adjust the adjusting screws according to your directions while you look in the focuser.)

After dark go out and point your telescope at Polaris, the North Star. With an eyepiece in the focuser, take the image out of focus. You will see the same image only now, it will be illuminated by starlight. If necessary, repeat the collimating process only keep the star centered while tweaking the mirror.

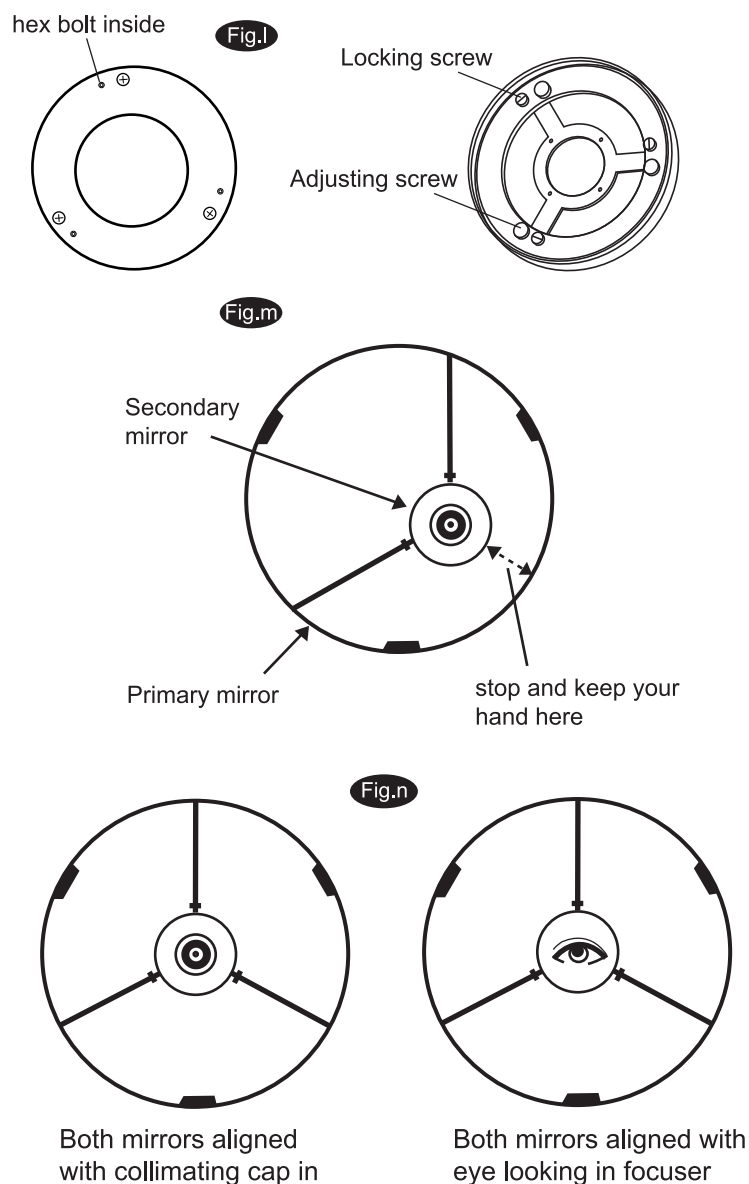

## Cleaning your telescope

Replace the dust cap over end of telescope whenever not in use. This prevents dust from settling on mirror or lens surface. Do not clean mirror or lens unless you are familiar with optical surfaces. Clean finderscope and eyepieces with special lens paper only. Eyepieces should be handled with care, avoid touching optical surfaces.

## TECHNICAL SUPPORT

Please contact your dealer for technical support.

## **Caution!**

NEVER USE YOUR TELESCOPE TO LOOK DIRECTLY AT THE SUN. PERMANENT EYE DAMAGE WILL RESULT. USE A PROPER SOLAR FILTER FOR VIEWING THE SUN. WHEN OBSERVING THE SUN, PLACE A DUST CAP OVER YOUR FINDERSCOPE TO PROTECT IT FROM EXPOSURE. NEVER USE AN EYEPiece-TYPE SOLAR FILTER AND NEVER USE YOUR TELESCOPE TO PROJECT SUNLIGHT ONTO ANOTHER SURFACE, THE INTERNAL HEAT BUILD-UP WILL DAMAGE THE TELESCOPE OPTICAL ELEMENTS.