

## Lungolinea Classic

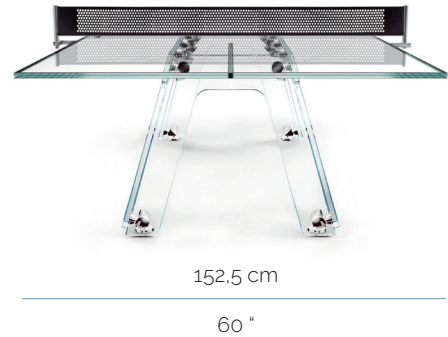
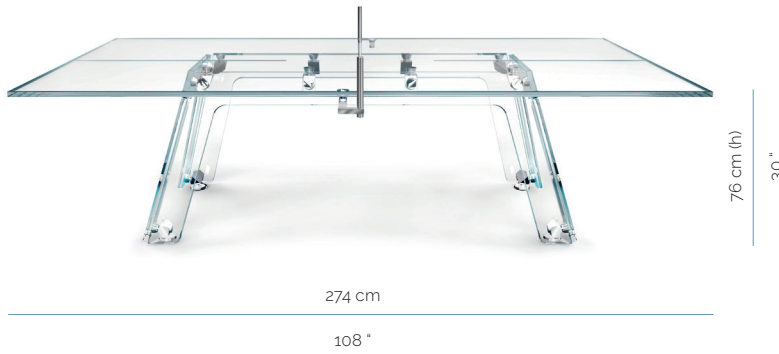

### MATERIALS

Low-iron glass  
Polished metal components  
Chrome connecting joints  
Alcantara® net

### PRODUCT WEIGHT

220 Kg / 485 lbs

### ACCESSORIES

1 Table tennis net kit  
2 Professional rackets  
4 Professional balls

### PACKAGING INFORMATION

204 cm x 151 cm x 40 cm (h)  
80" x 59" x 16" (h)  
340 kg / 750 lbs

### SELECTED METAL



Chrome



Black nickel

### DETAILS



Chrome metal components

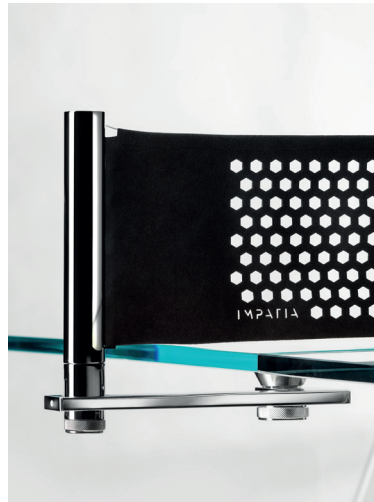

Removable Alcantara net



Black nickel metal components