



Design by Robert Law



595

* See reverse side for dimensions

595- Moka



- Elastic "Pirelli" webbing suspension system
- 2.4lb. high-density foam
- 100% top grain leather / Performance grade fabric
- Frames construction from kiln-dried hardwood and structural plywood
- Moveable back mechanism
- Large Ottoman and Separated Movable Back (As Corner)

Stock Program

Standard height: 33.5"

Special Order

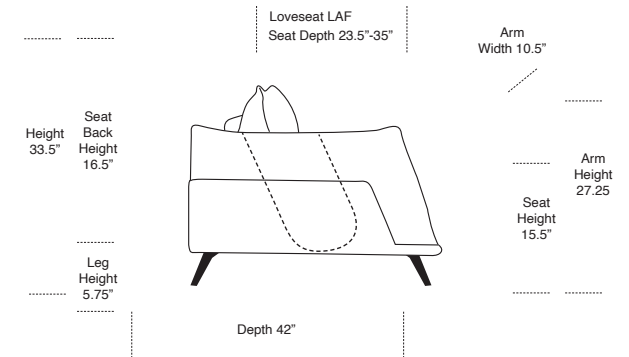
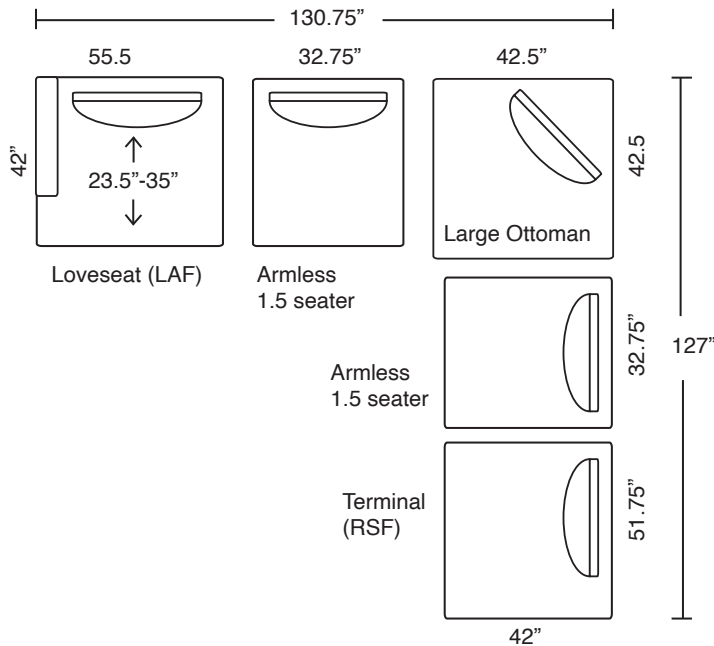

*Diagram is not to scale

Robert Law was born in Hong Kong in 1979. He was educated at The Hong Kong Polytechnic University. He received a BA (hon) in design in 2004. After graduation he spent few years to experience different fields of design. His work has covered many field ranging from the design of home appliances, small electronics, graphics & interior. In 2013 he began working in the furniture factory in China as R&D department manager. Since setting up his own design firm DESIGN HAO in Hong Kong 2013 he has developed sofas for brands such as XXL, Cuir Centre and HomeSalons in France, Moroni in US, Plush in Australia, Hunter Furniture in New Zealand and Casamia in Korean.