



* Assembly Guide & Warranty Card Included

ES900 TREADMILL OWNER'S MANUAL



ES900 TREADMILL OWNERS MANUAL

IMPORTANT:

All Products shown are prototype. Actual product delivered may vary.
Product specifications, features & software are subject to change without notice.
For the most up to date owner's manual please visit www.truefitness.com.
For documents in additional languages please visit www.truefitness.com/document-library/29/international-manuals

IMPORTANTE:

Todos los productos mostrados son prototipos. La realidad el producto suministrado puede diferir.
Especificaciones de productos, características y software están sujetas a cambios sin previo aviso.
Para la más actualizada de este manual del propietario, por favor visite www.truefitness.com
Para los documentos en otros idiomas, por favor visite www.truefitness.com/document-library/29/international-manuals

IMPORTANT:

Tous les produits présentés sont prototype. Le produit réel livré peut varier.
Spécifications du produit, caractéristiques et logiciels sont sujettes à modification sans préavis.
Pour la plus à jour le manuel du propriétaire s'il vous plaît visitez www.truefitness.com.
Pour documents dans des langues supplémentaires, veuillez www.truefitness.com/document-library/29/international-manuals de visite

重要提示：

显示所有产品的原型。实际交付的产品可能有所不同
产品规格，功能和软件如有更改，恕不另行通知
迄今为止对于大多数的使用说明书，请访问www.truefitness.com
对于其他语言的文档，请访问www.truefitness.com/document-library/29/international-manuals

هام:

جميع المنتجات المعروضة هي النموذج. قد تختلف المنتج الفعلي تسليمها.
مواصفات المنتج، والميزات والبرامج قابلة للتغيير دون إشعار.
www.truefitness.com ما يصل حتى الآن دليل المالك يرجى زيارة
www.truefitness.com/document-library/29/international-manuals للمستندات في لغات إضافية، يرجى زيارة

WICHTIG:

Alle hier gezeigten Produkte sind Prototypen. Das tatsächliche Produkt ausgeliefert wird, kann variieren.
Produkt-Spezifikationen, Funktionen und Software können sich ohne vorherige Ankündigung ändern.
In den meisten Fällen bis zu Bedienungsanleitung Bisher besuchen Sie bitte www.truefitness.com.
Für Dokumente in weiteren Sprachen finden Sie unter www.truefitness.com/document-library/29/international-manuals

BELANGRIJK:

Alle getoonde producten zijn prototype. Daadwerkelijke product geleverd kan verschillen.
Product specificaties, eigenschappen & software zijn onderhevig aan verandering zonder kennisgeving.
Voor de meest actuele handleiding van de eigenaar kunt u terecht www.truefitness.com.
Voor documenten in andere talen kunt u terecht op www.truefitness.com/document-library/29/international-manuals

ВАЖНО:

Все товары указаны прототипа. Фактический продукт, поставляемый могут отличаться.
Технические характеристики, особенности и программного обеспечения могут быть изменены без предварительного уведомления.
Для получения самой последней на сегодняшний день руководство по эксплуатации пожалуйста, посетите www.truefitness.com
Для документов на другие языки, пожалуйста, посетите www.truefitness.com/document-library/29/international-manuals

ES900 TREADMILL OWNERS MANUAL

Frank Trulaske, founder and CEO of TRUE, has had the same simple philosophy of delivering superior products, service and support for over 30 years. Today, TRUE is the global leader in premium cardio equipment for the commercial and residential markets. Our goal is to be the leader in technology, innovation, performance, safety and style. TRUE has received many awards for its commercial and retail product over the years and remains the benchmark for the industry. Fitness facilities and consumers invest in TRUE products for their durable commercial platforms used in all its cardio products, both commercial and residential alike.

The proud manufacturing tradition of quality and the culture of innovation at TRUE have given rise to a full line of truly extraordinary treadmills, indoor cycles and elliptical cross-trainers. As a result, people all over the world are benefiting from the TRUE experience. Innovation across the full product line has made TRUE successful and is a trademark of the TRUE heritage. TRUE's patented Heart Rate Control® technology is just one of the remarkable ways we deliver simple and superior performance every user can enjoy, and most importantly, use to achieve personal health and fitness goals.

TRUE strives to perfect biomechanically correct and orthopedically comfortable, functional products. Whether it be the mesh seat in the recumbent bike, the Soft Step® in the elliptical cross-trainers or the Soft System® in our treadmills, we deliver the best.

At the heart of our success is the relentless and systematic life testing of both our products and their components. We have dedicated employees who understand our philosophy is to deliver the best products in the world.

Our goal is not to sell the most cardio products in the world, but to deliver the world's best premium equipment for our customers' health and fitness solutions.

To own a TRUE machine is to be part of an exclusive fitness community that delivers results – your results.

Thank you for becoming a part of the TRUE experience.

TRANSCEND ALL OTHERS!

ES900 TREADMILL OWNERS MANUAL

TABLE OF CONTENTS:

Chapter 1: Safety Instructions

Safety Instructions.....	1
Use of Safety Key.....	4
Space Requirements.....	4
Grounding Instructions.....	5
Power Requirements.....	6
Warning Decals.....	7
Compliances.....	7

Chapter 2: Assembly Instructions

Pre-Assembly Checklist.....	9
Assembly Steps.....	11

Chapter 3: Product Overview

Treadmill Overview.....	33
-------------------------	----

Chapter 4: Programming & Operation

Heart Rate Monitoring.....	35
Heart Rate Control.....	36
Program Descriptions.....	37
Virtual Active® Videos.....	41

Chapter 4A: Transcend Operation

Transcend Overview.....	43
Touchscreen Introduction.....	45
Touchscreen Navigation.....	45
Web Browser.....	51
iPod® Integration.....	52
Bluetooth Audio.....	53
TV Controls.....	55
Virtual Active®.....	56
Netpulse®.....	56
Advanced Console Functions.....	57

Chapter 4B: Escalate¹⁵ Operation

Escalate ¹⁵ Overview.....	75
Console Navigation.....	77
TV Controls.....	81
iPod® Integration.....	82
Bluetooth Audio.....	83
Advanced Console Functions.....	85

Chapter 4B: Escalate⁹ Operation

Escalate 9 Overview.....	102
Console Navigation.....	104
Advanced Console Functions.....	110

Chapter 5: Care & Maintenance

Care & Maintenance.....	118
Cleaning the Equipment.....	118
Running Belt Alignment.....	119
Tensioning the Running Belt.....	120
Treadmill Lubrication.....	120
Leveling the Treadmill.....	121
Other Scheduled Preventive Maintenance.....	121
Long Term Storage.....	121

Chapter 6: Customer Service

Contacting Service.....	122
Contacting Sales.....	122
Reporting Freight Claims or Parts Damage.....	123

Chapter 7: Additional Information



Troubleshooting Guide.....	124
Product Specifications.....	130
Warranty Information.....	132

CHAPTER 1: SAFETY INSTRUCTIONS







IMPORTANT SAFETY INSTRUCTIONS

SAVE THESE SAFETY INSTRUCTIONS

This treadmill is intended for in-home use only; do not use this treadmill in a commercial or institutional setting. Doing so may void the expressed warranty.

-  WARNING: All EXERCISERS MUST READ ALL INSTRUCTIONS BEFORE USING THE TREADMILL.
-  WARNING: Heart rate monitoring systems may be inaccurate for some individuals. Over-exercising may result in serious injury or death. If you feel faint, stop exercising immediately.
-  WARNING: Equipment should be immediately taken out of use if it fails to work properly or when a warning is presented electronically.

TRUE STRONGLY recommends seeing a physician for a complete medical exam before undertaking an exercise program, particularly if the user has a family history of high blood pressure or heart disease, is over the age of 45, smokes, has high cholesterol, is obese or has not exercised regularly in the past year. Additionally, TRUE recommends consulting a fitness professional on the correct use of this product. If at any time while exercising the user experiences faintness, dizziness, pain or shortness of breath, he or she must stop immediately.

-  WARNING: To reduce the risk of electrical shock, always unplug this TRUE product before cleaning or attempting any maintenance activity. Do not handle the plug with wet hands.
-  WARNING: To reduce the risk of burns, fire, electric shock or injury, it is imperative to connect each product to a properly grounded 110V electrical outlet. A risk of electrical shock may result from improper connection of the equipment's grounding conductor. Check with a qualified electrician if you are unsure about proper grounding techniques. Do not modify the plug provided with this product. If it will not fit an electrical outlet, have a proper outlet installed by a qualified electrician. Your TRUE Fitness product must be properly grounded to reduce risk of shock if the treadmill malfunctions. Your treadmill is equipped with an electrical cord, which includes an equipment grounding conductor and a grounding plug. The plug must be inserted into an outlet that has been properly installed and grounded in accordance with all local codes and ordinances. A temporary adapter cannot be used to connect this plug to a two-pole receptacle in North America. If a properly grounded 15 amp outlet is not available, a qualified electrician must install one.
-  WARNING: Do not move the equipment by lifting the console. Do not use the console as a handlebar during a workout.
-  WARNING: This product contains chemicals known to the state of California to cause cancer and birth defects or other reproductive harm.
-  WARNING: Keep equipment stable on flat ground.
-  WARNING: Replace warning labels that may be worn, damaged or missing
-  WARNING: Replace any non-working or damaged components; remove the unit from service until repair is performed.

CHAPTER 1: SAFETY INSTRUCTIONS



WARNING: To reduce the risk of burns, fire and electric shock or injury to persons, follow these instructions:

- This appliance should never be left unattended when plugged in.
- Do not use any type of extension cord with this product.
- Unplug it from the outlet when not in use and before any servicing.
- Do not operate the equipment while being covered with a blanket, plastic, or anything that insulates or stops airflow.



WARNING: Risk of personal injury-crushing hazard when treadmill is in operation - Keep feet, hands, and fingers away from moving parts.

CAUTION:

- Health related injuries may result from incorrect or excessive use of exercise equipment.
- Do not use typing or web surfing features at excessive speeds. Always stabilize yourself by holding a stationary handle when using typing or web surfing features. (Varies by console option)
- Do not use the contact heart rate grips as a handlebar during a workout.
- Any changes or modifications to this equipment could void the product warranty.
- To disconnect, turn power OFF at the ON/OFF switch if applicable, then remove plug from electrical outlet.
- Never operate a TRUE product if it has a damaged power cord or electrical plug, or if it has been dropped, damaged, or even partially immersed in water. Contact TRUE Customer Service for a replacement.
- Use a TRUE AC power cord or AC/DC adapter only.
*Note the plug configuration for the power adapter may vary by country.
- Position this product so the power cord plug is accessible to the user.
- Keep the power cord away from heated surfaces. Do not pull the equipment by the power cord or use the cord as a handle. Do not run the power cord along the side or under the treadmill.
- If the electrical supply cord is damaged it must be replaced by the manufacturer, an authorized service agent, or a similarly qualified person to avoid a hazard.
- Do not use this product in areas where aerosol spray products are being used or where oxygen is being administered. Such substances create the danger of combustion and explosion.
- Always follow the console instructions for proper operation.
- Close supervision is necessary when used near children under the age of 15, or disabled persons.
- Do not use this product outdoors, near water, while wet, or in areas of high humidity including extreme temperature changes
- Never operate a TRUE product with the air openings blocked. Keep air openings free of lint, hair or any obstructing material.
- Never insert objects into any openings in this product. If an object should drop inside, turn off the power, unplug the power cord from the outlet and carefully retrieve it. If the item cannot be reached, contact TRUE Customer Service.
- Never place liquids of any type directly on the unit except in the accessory tray or bottle holders. Containers with lids are recommended.
- Wear shoes with rubber or high traction soles. Do not use shoes with heels, leather soles, cleats or spikes. Make sure no stones are embedded in the soles. Do not use this product in bare feet. Keep all loose clothing, shoelaces and towels away from moving parts.
- Do not reach into or underneath the unit, or tip it on its side during operation.

CHAPTER 1: SAFETY INSTRUCTIONS

⚠ CAUTION (CONTINUED):

- Use correct ergonomic positioning while running on treadmill.
- Do not allow animals on or near the equipment while in operation.
- Use the side handrails whenever additional stability is required. In case of emergency, such as tripping, the side handrails should be grabbed and the user should place his/her feet on the side platforms. The front handlebars should be used to grasp the heart rate sensors or to rest the hand on while operating the activity zone keys, but not for stability, emergency, or continuous use.
- Do not exceed maximum user weight of 400 lbs (181 kg).
- Do not use if you have a cold or fever.
- When using this exercise machine, basic precautions should always be followed.
- Use this equipment only for its intended use as described in this manual.
- Do not use attachments not recommended by the manufacturer.
- Allow only trained personnel to service this equipment.
- Avoid the possibility of bystanders being struck or caught between moving parts by making sure that they are out of reach of the equipment while it is in motion.
- This appliance can be used by children aged from 8 years and above and persons with reduced physical, sensory or mental capabilities or lack of experience and knowledge if they have been given supervision or instruction concerning use of the appliance in a safe way and understand the hazards involved.
- Children shall not play with the appliance.
- Cleaning and user maintenance shall not be made by children without supervision.
- Allow only one person at a time on the equipment while it's operating.
- It is the sole responsibility of the owner/operator to ensure regular and scheduled maintenance is performed.
- To avoid injury stand on the side rails before starting the treadmill.
- Avoid exiting treadmill while leaving the tread belt in motion.
- Never walk or jog backwards on the treadmill.

⚠ CAUTION:

- To avoid serious injury, do not touch the incline rack while the treadmill is in use.
- To avoid serious injury, do not touch the belt while the treadmill is in use.

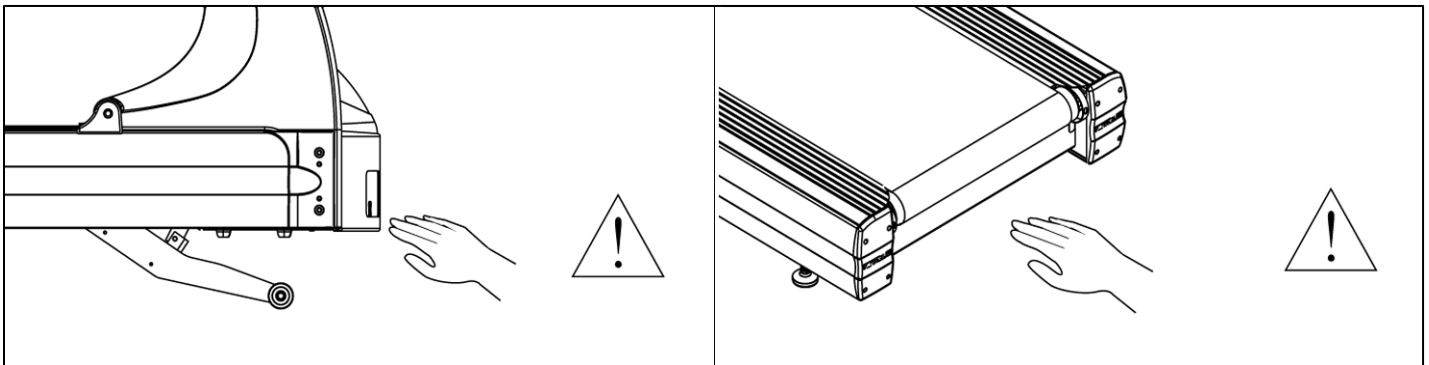

CHAPTER 1: SAFETY INSTRUCTIONS

USE OF SAFETY KEY (E-STOP):

- Attach the safety clip to your clothing before each workout and when treadmill is in use. (See Fig 2)
- Attach the magnetic key to the treadmill console assembly

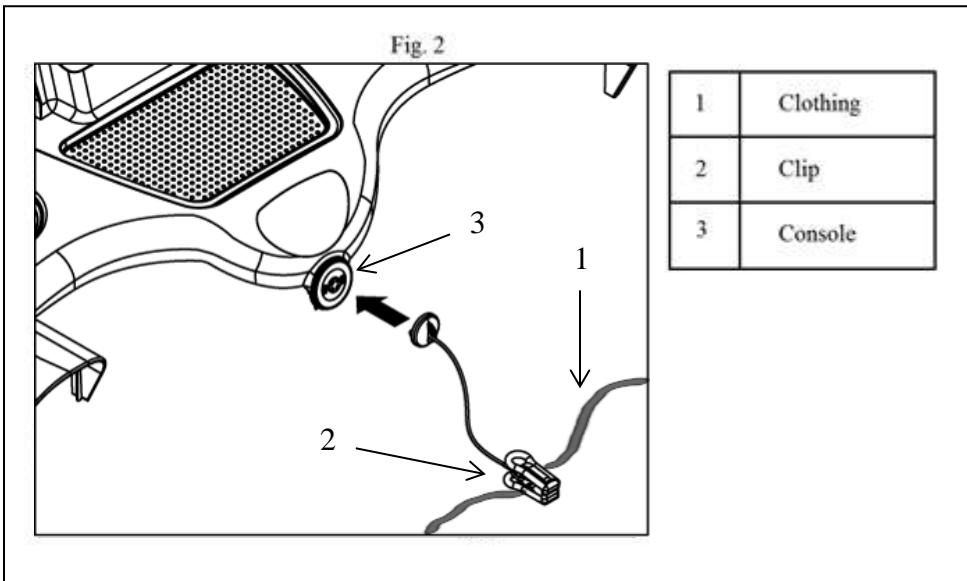

SPACE REQUIREMENTS:

TRUE's recommendation is to leave a minimum of 20" (0.5m) on each side of the treadmill and a 79" (2 m) safety zone at the rear of the treadmill. (See Fig 1)

Fig. 1

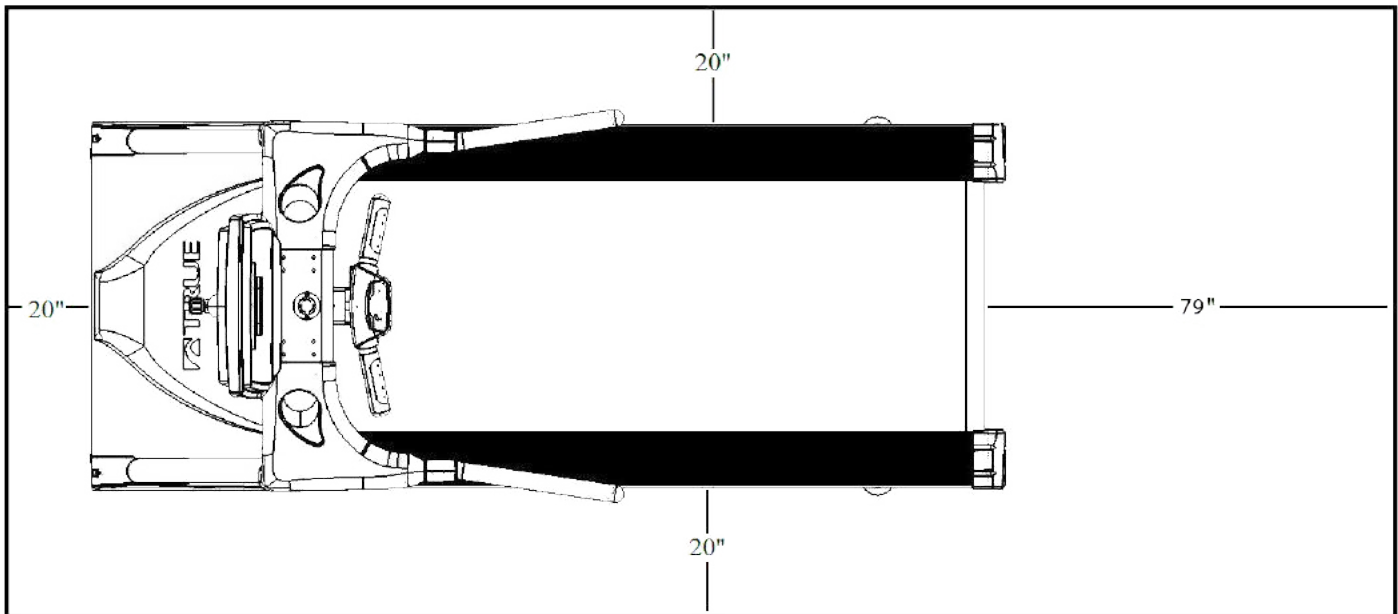

CHAPTER 1: SAFETY INSTRUCTIONS

GROUNDING INSTRUCTIONS:

This product must be grounded, if it should malfunction or breakdown, grounding provides a path of least resistance for electric current to reduce the risk of electric shock. This product is equipped with a cord having an equipment-grounding conductor and a grounding plug. The plug must be plugged into an appropriate outlet that is properly installed and grounded in accordance with all local codes and ordinances.

DANGER:

- Improper connection of the equipment-grounding conductor can result in a risk of electric shock.
- Check with a qualified electrician or serviceman if you are in doubt as to whether the product is properly grounded. Do not modify the plug provided with the product. If it will not fit the outlet, have a proper outlet installed by a qualified electrician.
- Do not remove the motor cover or you may risk injury due to electric shock.
- The 120-V model is for use on a nominal 120-V circuit and has a grounding plug that looks like the plug illustrated in figure A. Make sure the product is connected to an outlet having the same configuration as the plug. No adaptor should be used with this product.
- The 230-V model is for use on a circuit having a nominal rating more than 120-V and is factory-equipped with a specific electric cord and has a grounding plug that looks like the plug illustrated in figure B. Make sure that the product is connected to an outlet having the same configuration as the plug in Figure B. No adaptor should be used with this product. If the product must be reconnected for use on a different type of electric circuit, the reconnection should be made by qualified service personnel.

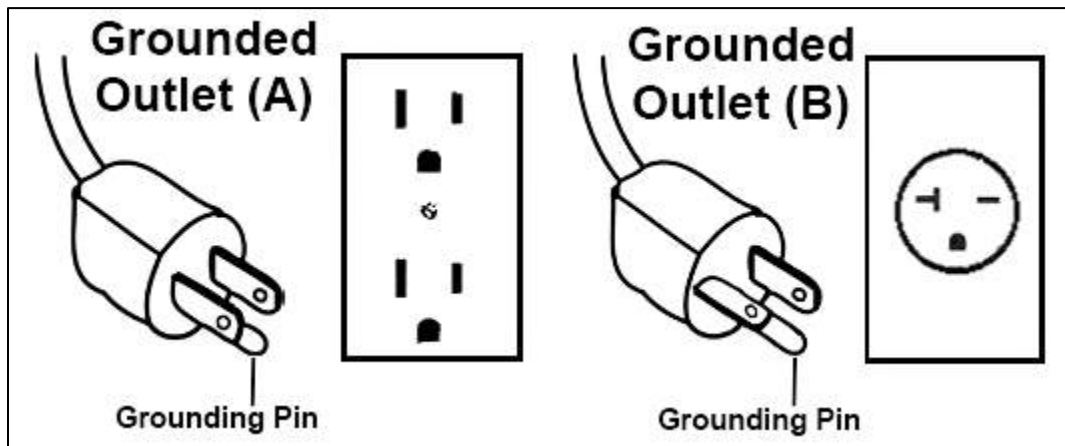

CHAPTER 1: SAFETY INSTRUCTIONS

POWER REQUIREMENTS FOR **TRUE** PRODUCTS

Information Sheet 2010

NOTE: Read and understand all instructions on this sheet and in the Owner's manual before plugging any TRUE power cord into an electrical outlet. This information sheet will help you identify the voltage and cords you need where you live and will outline requirements for:

- Grounded, dedicated lines
- Voltage
- Power cords
- Power adapters
- Extension cords

!DANGER: Improper connection of the equipment-grounding conductor can result in risk of electric shock. Check with a qualified electrician or service provider if you are in doubt as to whether the equipment is properly grounded or installed on a dedicated line. Seek a qualified electrician to perform any modifications to the cord or plug. TRUE is not responsible for injuries or damages as a result of cord or plug modification.

!CAUTION: Place cords away from heat (such as baseboards). Use care to arrange any cord so it doesn't become an obstacle.

Extension Cords

Do not use an extension cord to supply power to any TRUE product.

Grounded, Dedicated Line

TRUE equipment must be grounded. If it should malfunction or break down, grounding provides a path of least resistance for electric current to reduce the risk of electric shock. TRUE cords (except for cycle adapters) have an equipment-grounding conductor and a grounding plug. The plug must be plugged into an appropriate outlet that is properly installed and grounded in accordance with all local codes and ordinances where you live. Do not use a ground plug adapter to adapt the power cord to a non-grounded outlet. Do not use a GFCI outlet or GFCI circuit breaker. A dedicated line will assure that adequate power is available for safe operation over the life of your TRUE Product.

Voltage

Voltage required for your unit is located on the serial number decal (usually on the front of the unit). Depending on where you live voltage requirements differ.

For example, in the United States some TRUE treadmills require a circuit rated 115 VAC, 60 Hz and 20 amps. See Figure 1. However, a home typically has 15 amp outlets. In this case, contact an electrician to install a 20 amp dedicated line prior to use. See Figure 2.

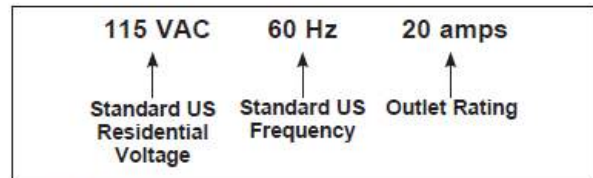

Figure 1

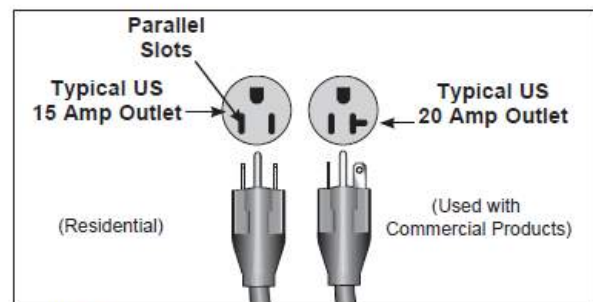

Figure 2

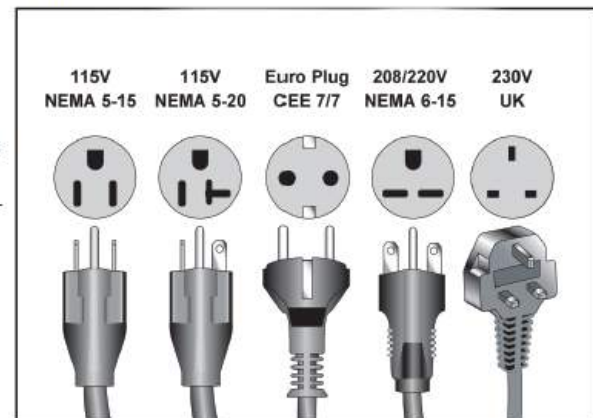

Figure 3

CHAPTER 1: SAFETY INSTRUCTIONS

WARNING DECALS:



WARNING: Replace warning labels that may be worn, damaged or missing

To replace any worn or missing warning decals contact TRUE FITNESS by visiting www.truefitness.com or contact customer service at 800-883-8783.

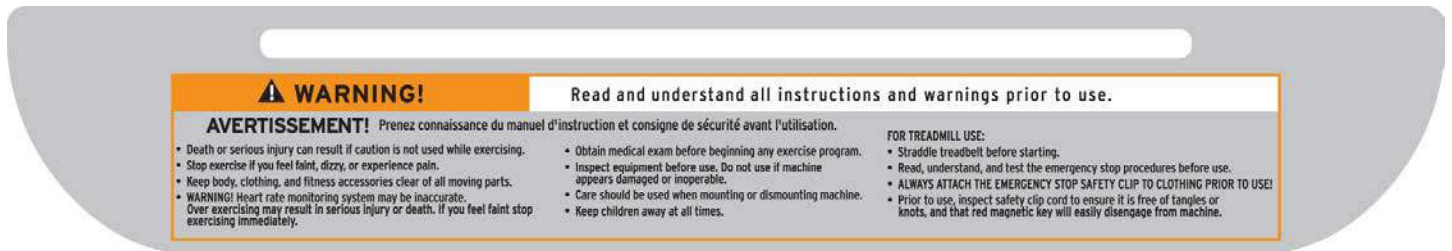

COMPLIANCES:

This equipment complies with all applicable codes and regulations. For a complete list of compliances, please visit www.truefitness.com

CHAPTER 2: ASSEMBLY INSTRUCTIONS

IMPORTANT SAFETY INSTRUCTIONS

- **Read and understand all instructions and warnings prior to use.**
- Obtain a medical exam before beginning any exercise program. If at any time during exercise you feel faint, dizzy, or experience pain, stop and consult your physician.
- Obtain proper instruction prior to use.
- This treadmill is intended for in-home use only.
- Inspect the treadmill for incorrect, worn, or loose components and do not use until corrected, replaced, or tightened prior to use.
- Do not wear loose or dangling clothing while using the treadmill.
- Care should be used when mounting or dismounting the treadmill.
- Read, understand, and test the emergency stop procedures before use.
- Disconnect all power before servicing the treadmill.
- Do not exceed maximum user weight of 400 lbs.
- Keep the top side of the moving surface clean and dry.
- Keep children and animals away.
- Use caution when moving and assembling treadmill.
- All exercise equipment is potentially hazardous. If attention is not paid to the conditions of equipment usage, death, or serious injury could occur.
- Save these instructions.

Basic Guidelines for Setting Up Your Treadmill:

After removing the treadmill from the packaging, place your treadmill on a clean, level surface. Make sure the electrical cord easily reaches a grounded three-pronged outlet and has enough slack to allow the deck to incline without tightening the cord. Do not allow the treadmill assembly to rest on the cord.

Important Electrical Requirements – 120V:

Your TRUE treadmill requires a dedicated 120 volt, alternating current (AC), 20 amp grounded outlet circuit. This means nothing else can be plugged into the same circuit. Most power circuits are rated for this 120V AC 20 amp requirement, but you must ensure the treadmill does not share the circuit with anything else.

Danger: Do not use an extension cord or ungrounded outlet:

The ground helps prevent electrical damage to your treadmill and enhances your safety by helping to prevent shock. Check with a qualified electrician or serviceman if you are in doubt as to whether the treadmill is properly grounded. Do not modify the plug provided with the treadmill if it will not fit the outlet. Have a proper outlet installed by a qualified electrician.

CHAPTER 2: ASSEMBLY INSTRUCTIONS

PRE-ASSEMBLY CHECK LIST:

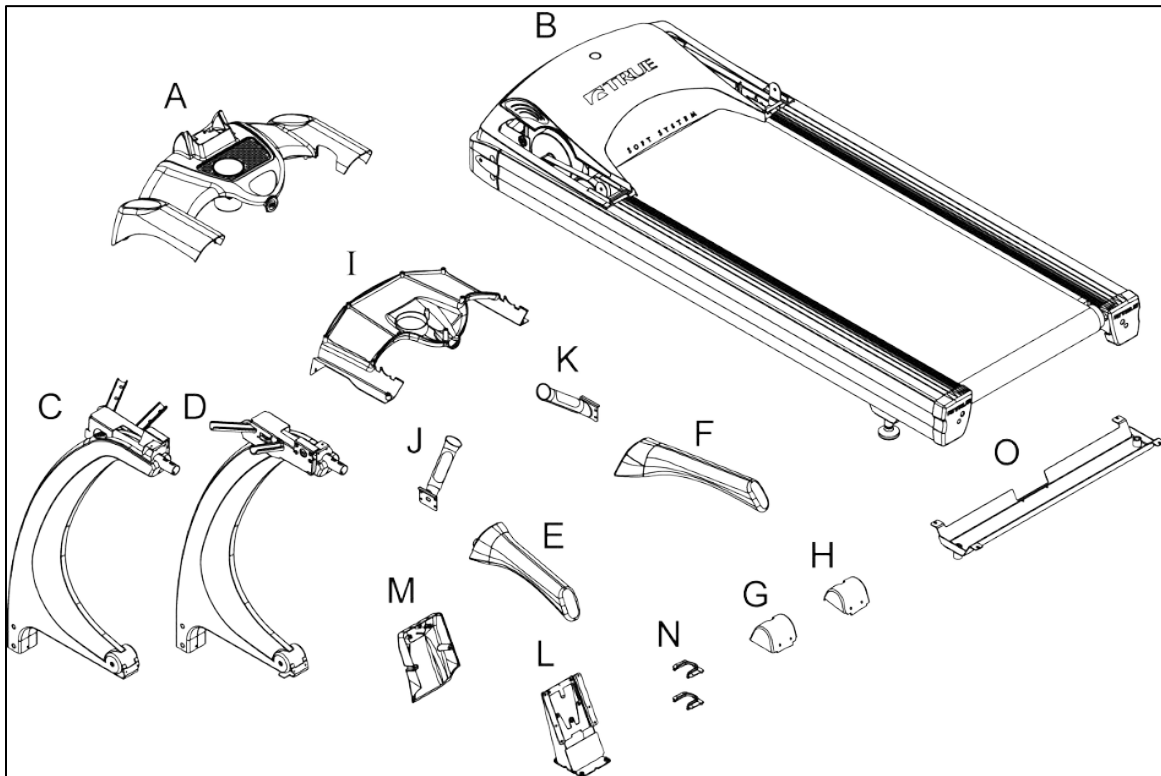

<u>Item</u>	<u>Description</u>	<u>Qty</u>
A	Console Rack	1
B	Frame	1
C	Pedestal - Left	1
D	Pedestal - Right	1
E	Handrail - Left	1
F	Handrail - Right	1
G	Pivot Trim Cover - Left	1
H	Pivot Trim Cover - Right	1
I	Lower Console Rack Cover	1
J	Hand Grip Assembly - Left	1
K	Hand Grip Assembly - Right	1
L	Console Mast	1
M	Rear Console Cover	1
N	Hand Grip Base Cover	2
O	Decline Foot	1

CHAPTER 2: ASSEMBLY INSTRUCTIONS

PRE-ASSEMBLY CHECK LIST (CONTINUED):

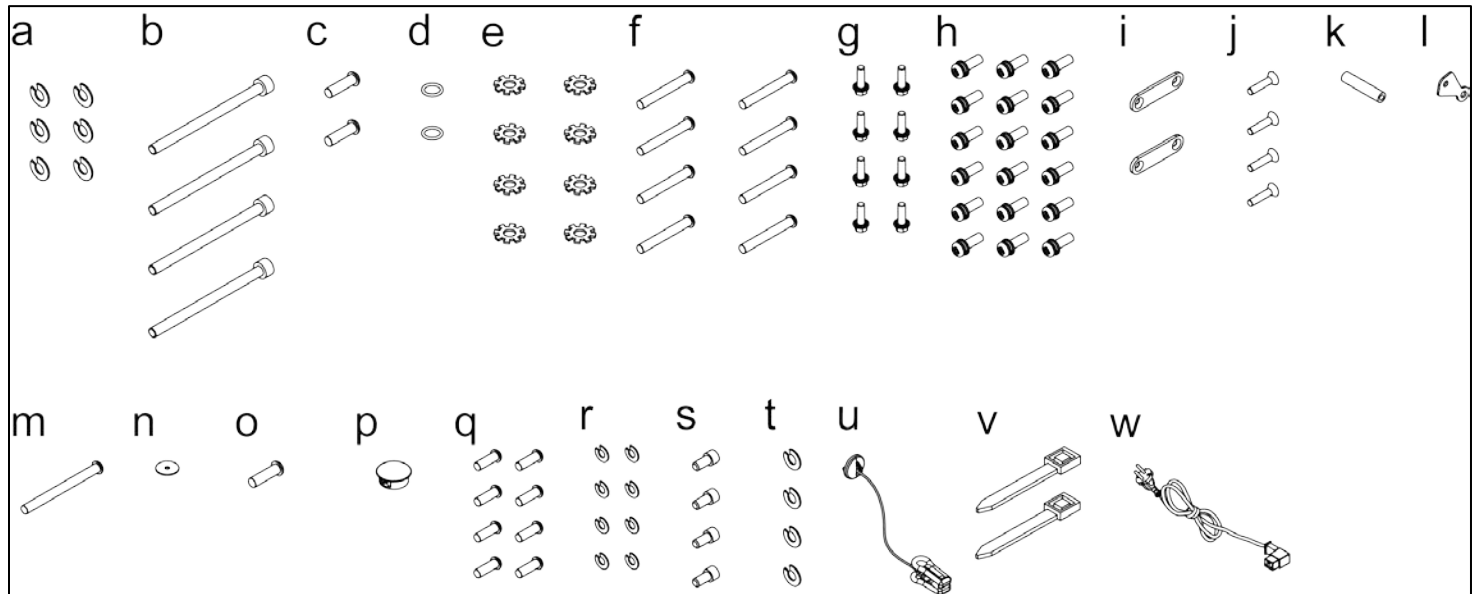

<u>Item</u>	<u>Description</u>	<u>Qty</u>
a	Spring washer 3/8"	6
b	Bolt 3/8"-16x140mm	4
c	Bolt 3/8"-16x20mm	2
d	O ring	2
e	Outer tooth washer M8	8
f	Truss hex screw 5/16"-24x38mm	8
g	Screw 1/4"-20x20mm	8
h	Round Philips screw M4xP0.7x12	18
i	Pivot Trim Cover Plate	2
j	Screw #10-32x15mm	4
k	Spacer	1
l	Power Cord Retainer	1

<u>Item</u>	<u>Description</u>	<u>Qty</u>
m	Round Philips screw M5xP0.8x60	1
n	Washer Ø6xØ19x1.5t	1
o	Screw M5xP0.8x20	1
p	Motor Cover Plug	1
q	Screw 1/4"-20UNFx16mm	8
r	Spring washer 1/4"	8
s	Bolt 5/16"-24x16mm	4
t	Spring washer M8	4
u	Safety Key	1
v	Wire Ties	2
w	Power cord	1

Tools Required (not included):

- 15/16, 7/8, 7/16 and 1/2 inch Open End Wrenches
- Long Nose Pliers
- 3/16 and 7/32 inch hex keys
- 7/16 inch socket with extension and ratchet
- #2 Phillips Screwdriver

CHAPTER 2: ASSEMBLY INSTRUCTIONS

TREADMILL ASSEMBLY STEPS:

⚠ CAUTION:

- Use caution when assembling treadmill. Unpacking and assembling of this treadmill is a two person task.
- Remove all treadmill components from packaging.

Step 1 Remove Motor Cover:

- a) Remove the screw (o) and washer (n) from the motor cover and set to the side.
- b) Remove the motor cover from the treadmill frame (B)

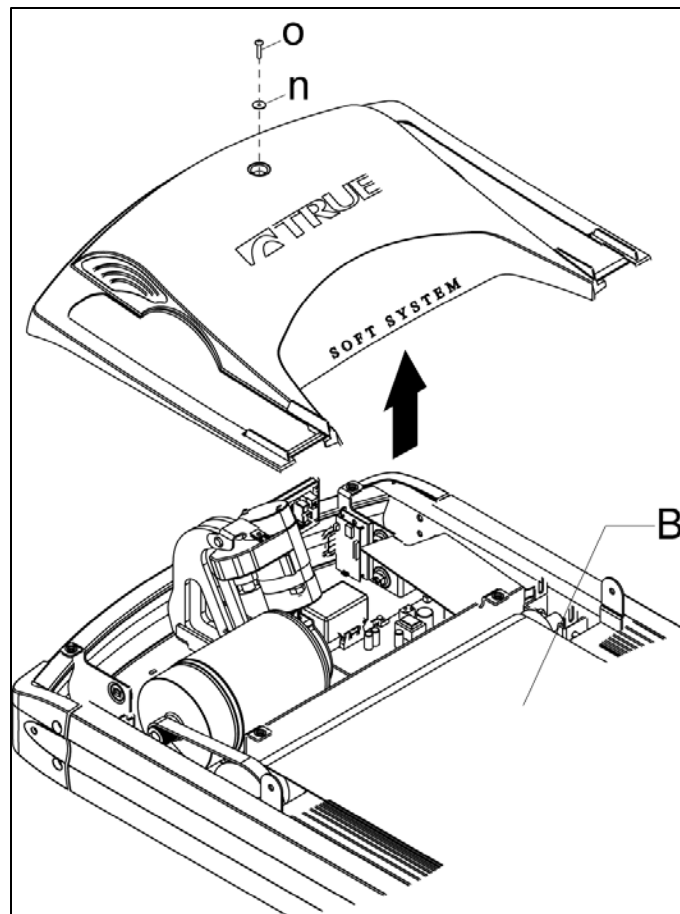

Fig. 1

CHAPTER 2: ASSEMBLY INSTRUCTIONS

TREADMILL ASSEMBLY STEPS (CONTINUED):

Step 2 Pedestal Installation:

- a) Place a section of cardboard onto right straddle cover as shown in Fig 2-1. Remove twist tie from cable bundle.
- b) Install Pedestal – R (D) into Frame (B) rotated down as shown in Fig. 2. This position will help prevent cable damage.
- c) Using 7/32 inch hex key, install Bolt 3/8-16 UNC x 3/4 (c) and Washer 3/8 – Split (a) into pivot of Pedestal – R but do not tighten yet.
- d) Insert Pedestal – L (C) into Frame as shown in Fig. 2 with bolt (c) and washer (a) but do not tighten yet.

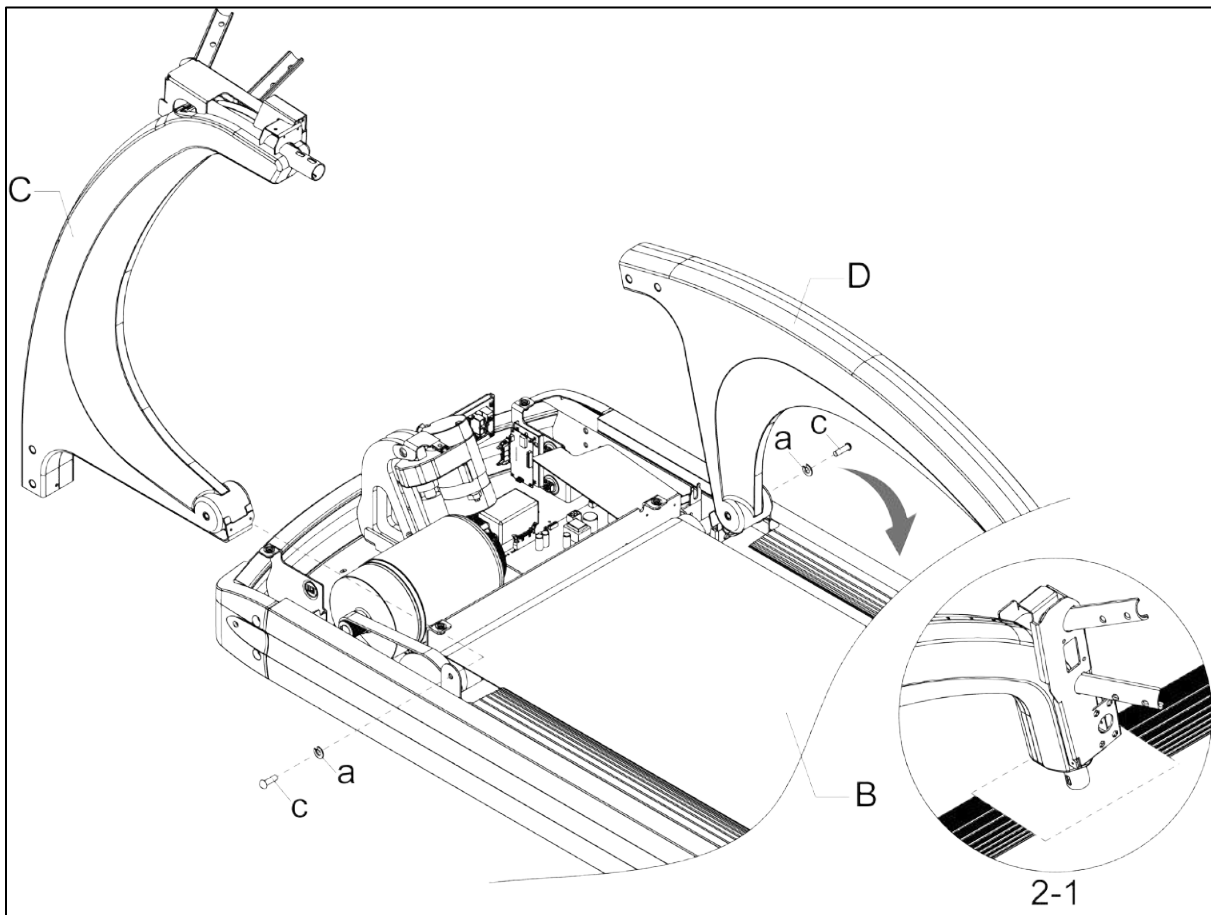

Fig. 2

⚠ CAUTION:

Pedestals can pivot until secured in front. Do not grab top of pedestal.

CHAPTER 2: ASSEMBLY INSTRUCTIONS

TREADMILL ASSEMBLY STEPS (CONTINUED):

Important Display Specification:

Verify on customer product order what type of display will be installed on this treadmill.

Listed below are the four display options for this series of treadmill.

Find the correct Display Option for assembly and follow frame cable routing (step 3) directions for either section **3-2A** or **3-2B** and for console cable connections (step 12) follow section **12A** or **12B**

Transcend <u>16" Touchscreen</u> Step 3-2A Step 12A	Transcend <u>10" Touchscreen</u> Step 3-2A Step 12A	Escalate <u>15" TFT</u> Step 3-2A Step 12A	Escalate <u>9" TFT</u> Step 3-2B Step 12B
--	--	---	--

NOTE: Cables will be labeled near their connector with identifying names such as those listed in **BOLD TEXT** throughout these instructions. Also listed in these instructions are the cable part numbers (KDCA-“xx”), which are called out in each step.

NOTE: See **TES900 Treadmill Frame Cable Connection Table** below for the cable connections summary.

TES900 Treadmill Cable Frame Connections				
Pedestal Cable or Power Supply	15" LCD with Touchscreen	15" TFT non Touchscreen	10" LCD with Touchscreen	9" TFT no Touchscreen
CNTRL CABLE	YES	YES	YES	YES
COAX CABLE	YES	YES	YES	YES
AUXILIARY POWER SUPPLY	REQUIRED - SHIPPED WITH DISPLAY CONSOLE. CUSTOMER INSTALLS	REQUIRED - SHIPPED WITH DISPLAY CONSOLE. CUSTOMER INSTALLS	REQUIRED - SHIPPED WITH DISPLAY CONSOLE. CUSTOMER INSTALLS	NA
COMM CABLE	YES	YES	YES	YES
CNTRL to AUXPS	NO	NO	NO	YES
TCPS POWER CORD to AUXPS	YES	YES	YES	NO
YES = MAKE CABLE CONNECTION NO = DO NOT CONNECT NA = NOT APPLICABLE				

NOTE: Reference **Wiring Schematic** and **Frame Cable Routing Diagram** contained in these assembly instructions. You may remove from packet to aid in assembly but if you remove we recommend you retain these diagrams with the instructions for future reference.

CHAPTER 2: ASSEMBLY INSTRUCTIONS

TREADMILL ASSEMBLY STEPS (CONTINUED):

Step 3-1 Frame Cable Connections:

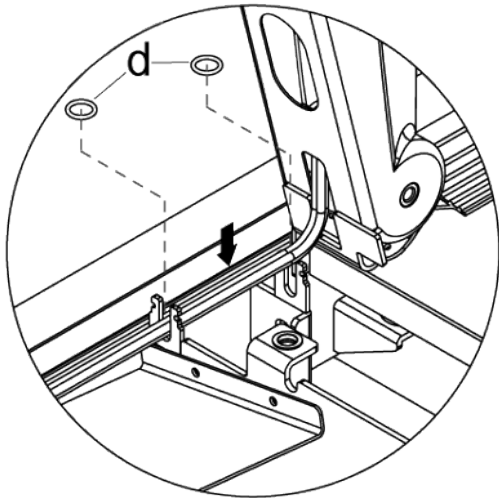

Fig 3-1-1

- a) Route the cables exiting from Pedestal – R into cable restraints and secure with two O-rings (d) as shown in Fig. 3-1-1 to the left. Eliminate any slack in cables to ensure they are not pinched when pedestals are upright.

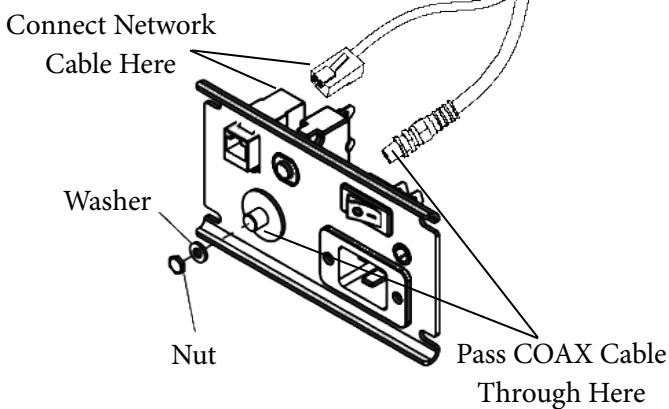

Fig 3-1-2

- b) Route the COAX Cable and Network Cable to the front of the treadmill frame.
- c) Connect the network cable to the network jack on the power plate as shown in Fig 3-1-2
- d) Remove nut and washer from front of COAX Cable as shown in figure 3-1-2
- e) Pass front of COAX Cable through hole in electrical panel and install washer and tighten nut using 1/2 inch open end wrench on nut and long nose pliers on connector portion of cable.

NOTE: Torque specification for tightening all COAX connections is 1.8 ft-lb

CHAPTER 2: ASSEMBLY INSTRUCTIONS

TREADMILL ASSEMBLY STEPS (CONTINUED):

Step 3-2A Frame Cable Connections:

*TOUCHSCREEN CONSOLES & 15" TFT CONSOLES ONLY

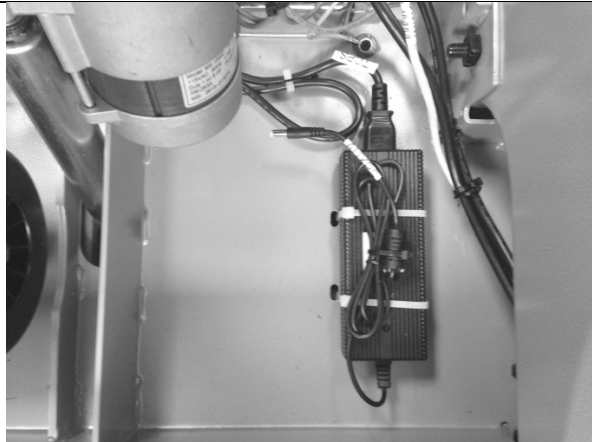

Picture 3-2A-1

- a) Place Auxiliary Power Supply (included in console box), in motor area floor location shown in picture 3-2A-1
- b) Connect TCPS Power Supply AC connector (large connector w/ 3 pins) into Auxiliary Power Supply as shown in picture. Make sure connector is fully inserted.
- c) Secure Auxiliary Power Supply to floor using the supplied wire ties.

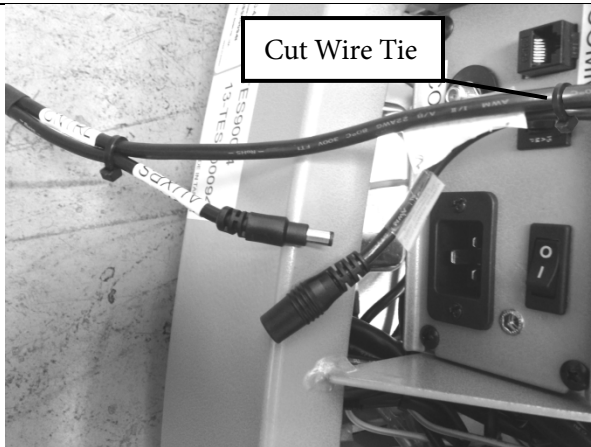

Picture 3-2A-2

- d) Separate the AUXPS cables that are attached to the CTRL cable and cut the wire tie holding the female end of the AUXPS cable to the CTRL cable as shown in picture 3-2A-2

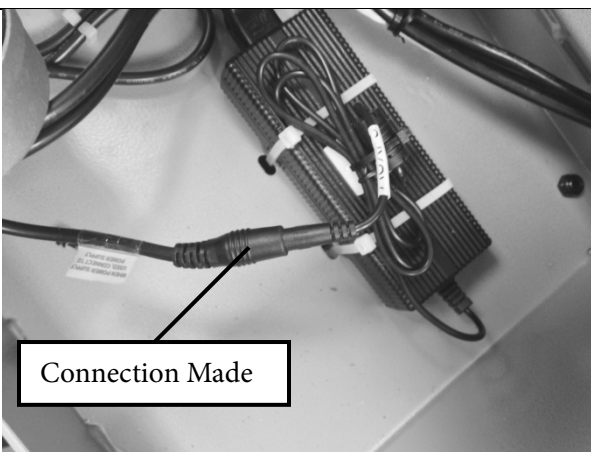

Picture 3-2A-3

- e) Connect the female end of the AUXPS Cable coming from Pedestal to AUXPS Power Supply Cable. See picture 3-2A-3

NOTE: The male end of the AUXPS cable wire tied to the CNTRL cable is not used for this installation.

CHAPTER 2: ASSEMBLY INSTRUCTIONS

TREADMILL ASSEMBLY STEPS (CONTINUED):

Step 3-2A Frame Cable Connections (continued):

***TOUCHSCREEN CONSOLES & 15" TFT CONSOLES ONLY**

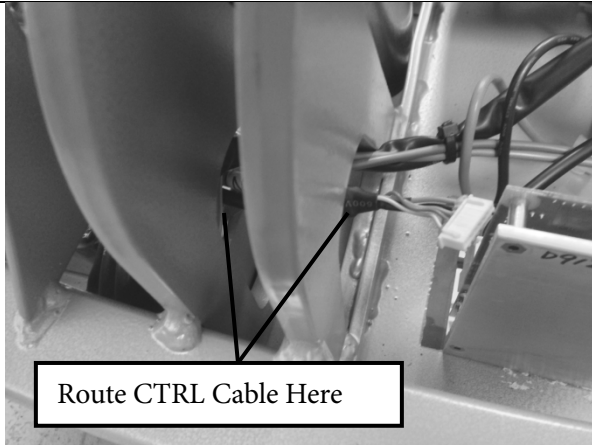

3-2A-4

- f) Route the CTRL cable through the cutouts in both incline tower plates as shown in Picture 3-2A-4.

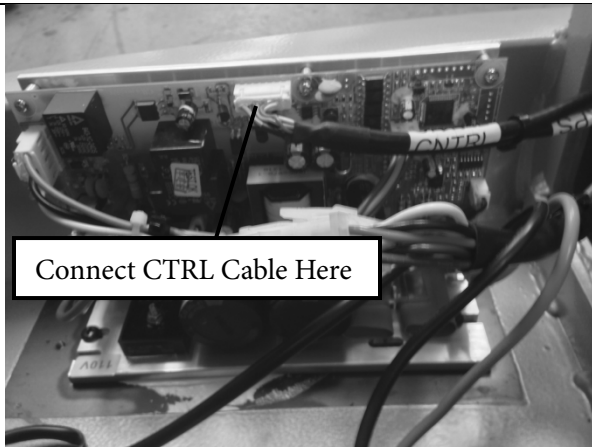

3-2A-5

- g) Connect the CNTRL cable to the lower control board as shown in picture 3-2A-5.

CHAPTER 2: ASSEMBLY INSTRUCTIONS

TREADMILL ASSEMBLY STEPS (CONTINUED):

Step 3-2B Frame Cable Connections:

*9" TFT CONSOLES ONLY

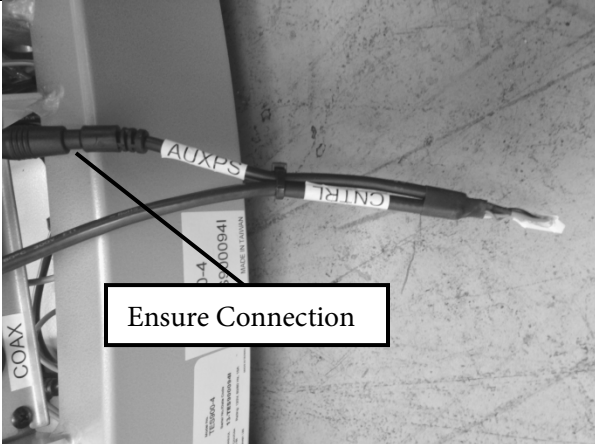
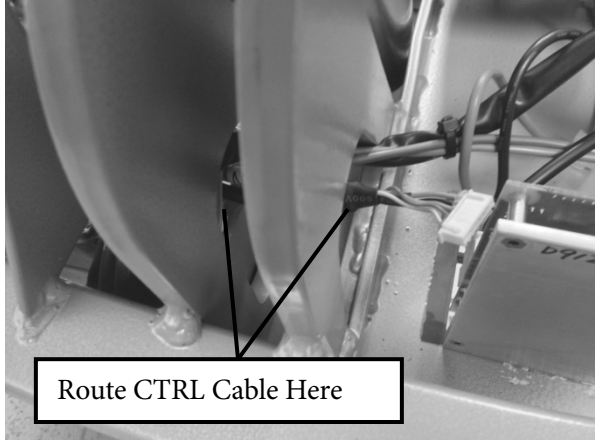
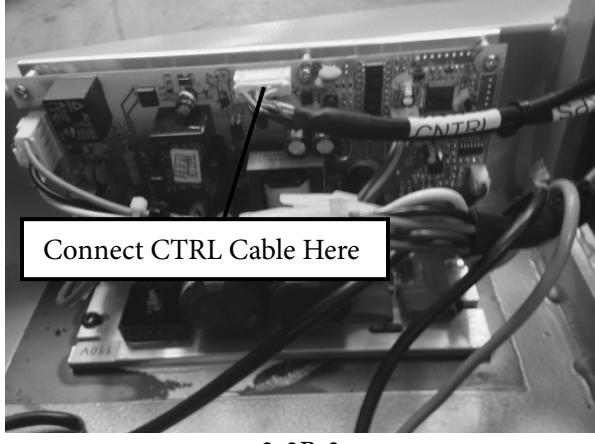
 <p>3-2B-1</p>	<p>a) Ensure the AUXPS cables that are attached to the CTRL cable are firmly connected as shown in picture 3-2B-1.</p>
 <p>3-2B-2</p>	<p>b) Route the CTRL cable through the cutouts in both incline tower plates as shown in Picture 3-2B-2.</p>
 <p>3-2B-3</p>	<p>c) Connect the CNTRL cable to the lower control board as shown in picture 3-2B-3.</p>

CHAPTER 2: ASSEMBLY INSTRUCTIONS

TREADMILL ASSEMBLY STEPS (CONTINUED):

Frame Cable Routing Diagram:

Once all parts of step 3 are complete, the treadmill frame wiring should resemble the diagram below.

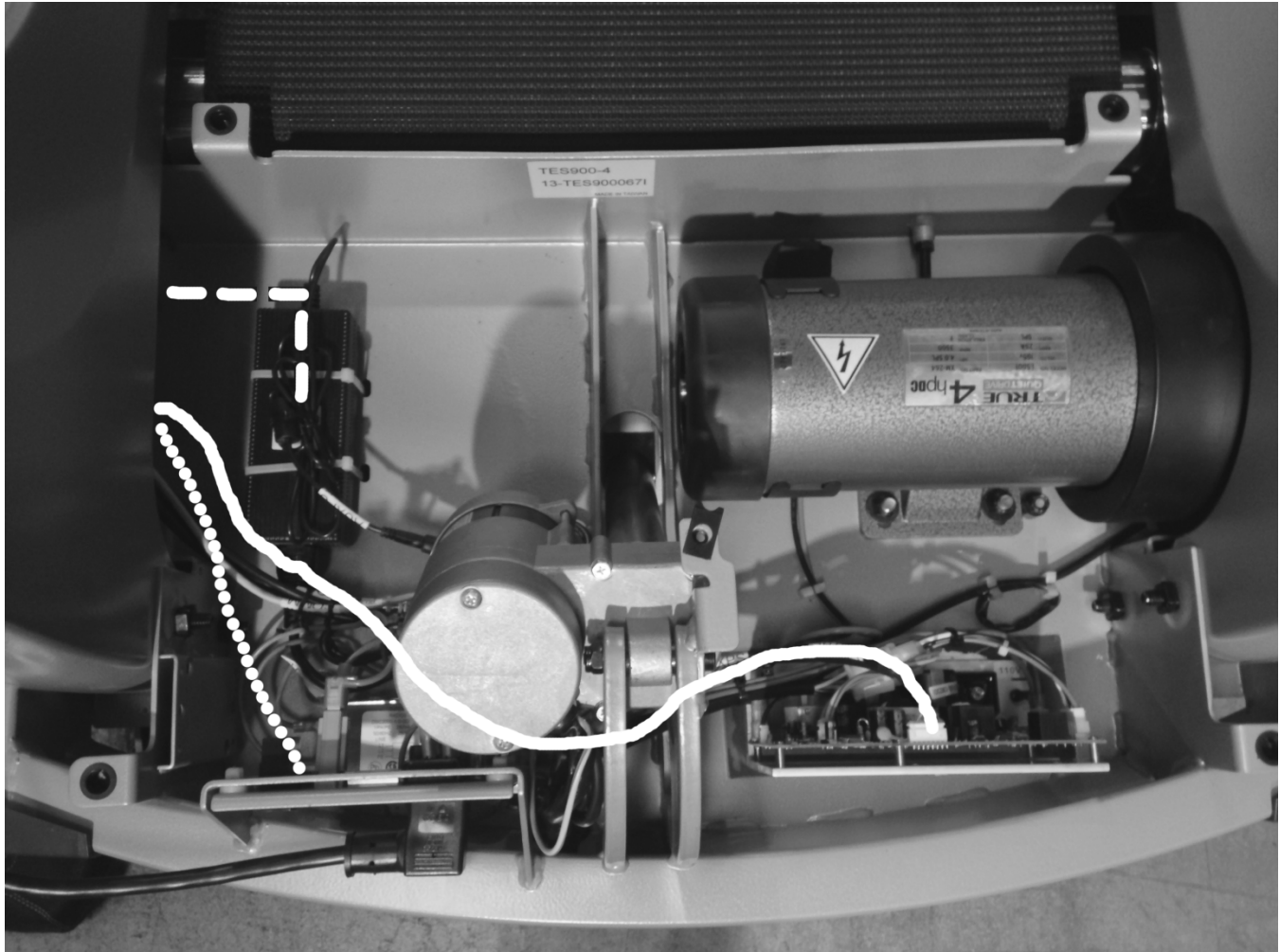

Touchscreen & 15" TFT Console

COAX & Network Cable
AUXPS - - - - -
CNRL Cable _____

9" TFT Console:

COAX & Network Cable
N/A
AUXPS/ CNRL Cable bundle _____

CHAPTER 2: ASSEMBLY INSTRUCTIONS

TREADMILL ASSEMBLY STEPS (CONTINUED):

Step 4 Pedestal Hardware and Motor Cover:

- a) Rotate Pedestal – R (D) upright as shown in Fig 4.
- b) Using 5/16 inch hex key, install, but **do not tighten**, two per side of Bolt 3/8-16 UNC x 5-1/2 (b) and Washer 3/8 Split (a) into front of Frame as shown in Fig. 4.

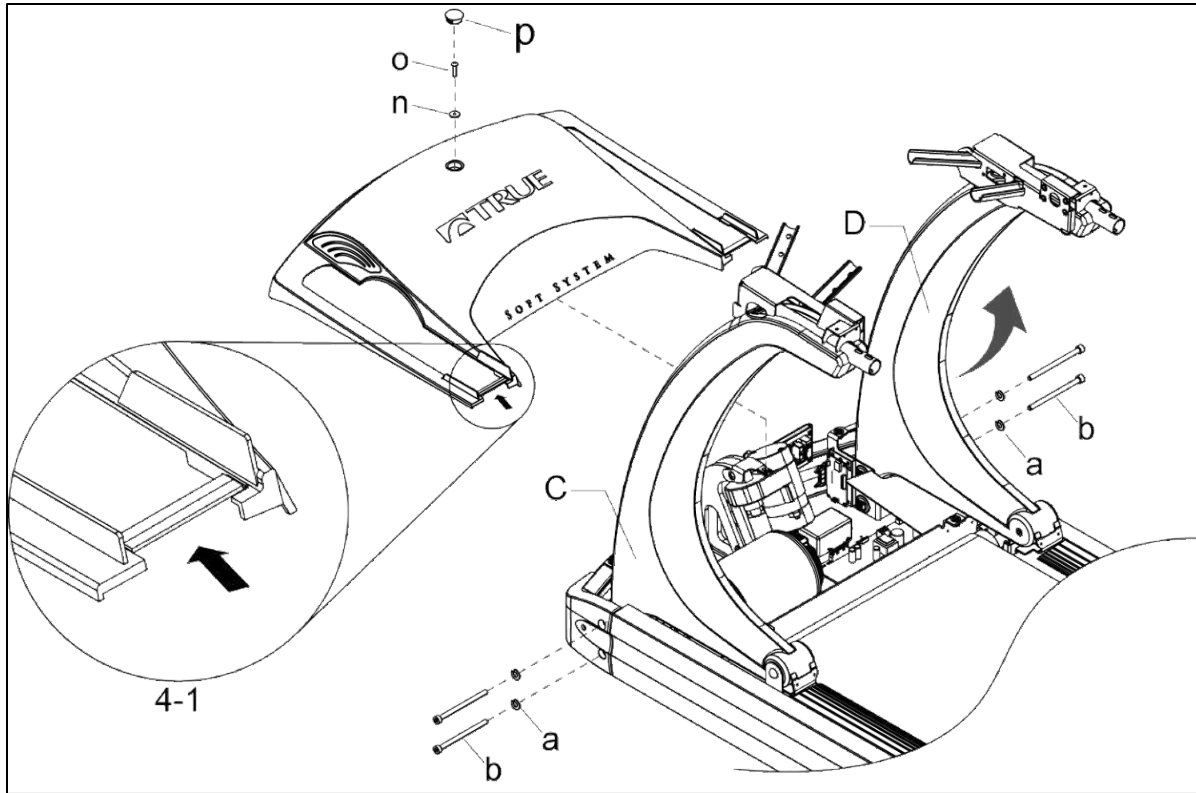

Fig. 4

- c) Remove ribs (right and left side) on Motor Cover as indicated by arrow in Fig. 4-1. Discard tabs.
NOTE: Hold inner portion of motor cover shown on right side of Fig. 4-1. Wiggle left side up and down until tab breaks on right side. Then grasp tab and wiggle until it breaks free. Repeat for right side of motor cover.
- d) Install Motor Cover using hardware; flat washer (n), screw (o), and then Cap – Motor Cover (p).

CHAPTER 2: ASSEMBLY INSTRUCTIONS

TREADMILL ASSEMBLY STEPS (CONTINUED):

Step 5 Hand Grip Assemblies:

- a. Connect the wires coming from the bottom of the hand grip assemblies (J, K) to the corresponding wires located in the pedestal arms (D, C) as shown in figure 5-1.
- b. Secure the hand grip assemblies (J, K) to the pedestal arms (D, C) with four screws (q) and four spring washers (r) on each side.

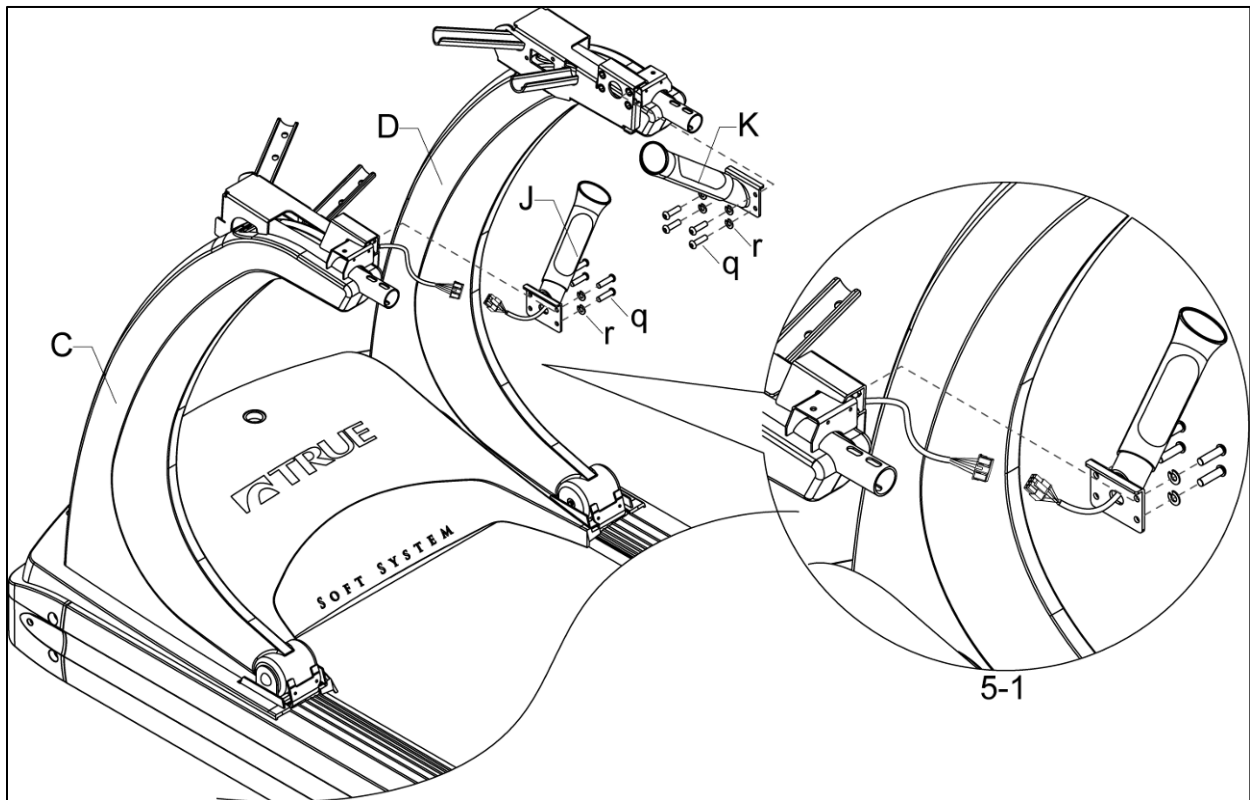

Fig. 5

CHAPTER 2: ASSEMBLY INSTRUCTIONS

TREADMILL ASSEMBLY STEPS (CONTINUED):

Step 6 Console Rack and Secure Pedestals:

- a) Install Console Rack (A) onto Pedestals R & L by resting Console Rack tubing on top of Pedestal tubing cradles.
NOTE: Force may need to be applied to the inside of the pedestals (C, D). Spreading the pedestals apart helps to ensure accurate console rack placement.
CAUTION: Do not pinch cabling during this step.
- b) Install 2 screws (h) under each side of the console rack (A) but do not tighten.
- c) Using 3/16 inch hex key, install, but do not tighten, eight Bolts 5/16-24 UNF x 1-1/2 (e) and external tooth washers M8 (d) through Pedestal tubing nest and into Console Rack. You may need to align Pedestal and Console Rack to install first bolt on right and left side.
- d) Tighten 4 screws (h) from STEP 6b.
- e) Tighten 8 bolts (f) from STEP 6c.
- f) Tighten 2 bolts from STEP 2, Bolt 3/8-16 UNC x 3/4 (c) at pivot point of Pedestal.
- g) Tighten 4 bolts from STEP 4, Bolt 3/8-16 UNC x 4-1/2 (b) at front of frame.

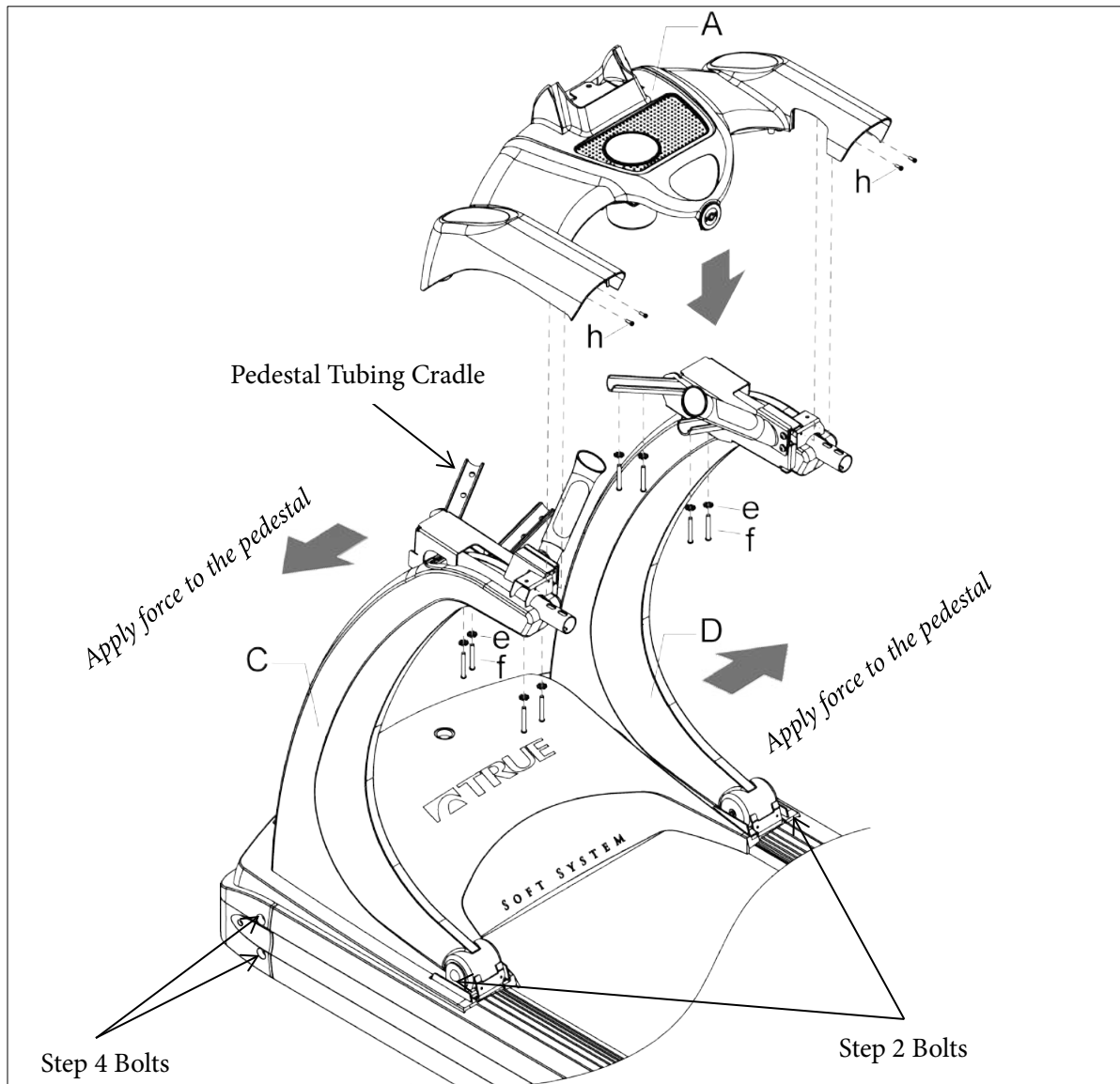

Fig. 6

CHAPTER 2: ASSEMBLY INSTRUCTIONS

TREADMILL ASSEMBLY STEPS (CONTINUED):

Step 7 Console Mast:

- a) Insert the console mast (L) into the console rack and secure it with 4 screws (s) and 4 spring washers (t), but do not tighten the screws completely until they have all been installed.

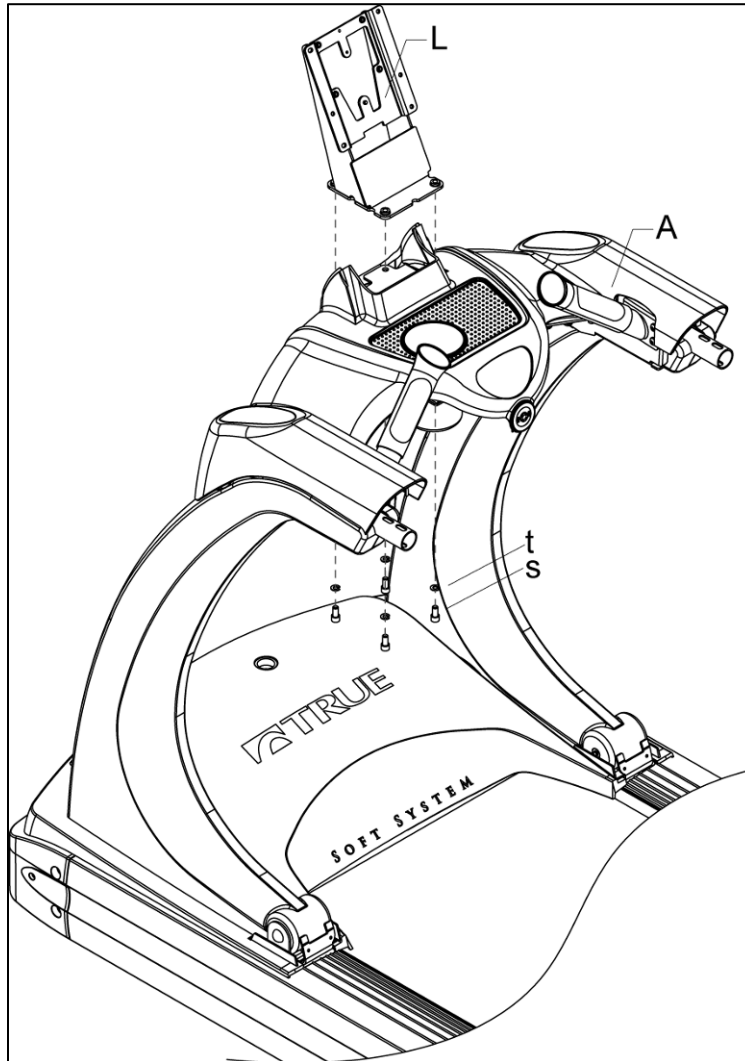

Fig. 7

CHAPTER 2: ASSEMBLY INSTRUCTIONS

TREADMILL ASSEMBLY STEPS (CONTINUED):

Step 8 Console Rack Cable Connections and Lower Cover Installation:

- a. Connect all wires from the right pedestal arm to the wires from the upper console rack cover (A) as shown in figure 9-1 (all cables will be connected regardless of console option).
*Do not over torque the coax TV cable.
- b. Fit all cables securely into the underside of the upper console rack cover (A).
- c. Install the hand grip base covers (N) into the upper console rack cover (A).
- d. Install the lower console rack cover (I) using eight screws (h), but do not tighten completely.
- e. Adjust the placement of the hand grip base covers to ensure the correct fit while taking care not to pinch any wires
- f. Tighten the screws (h).

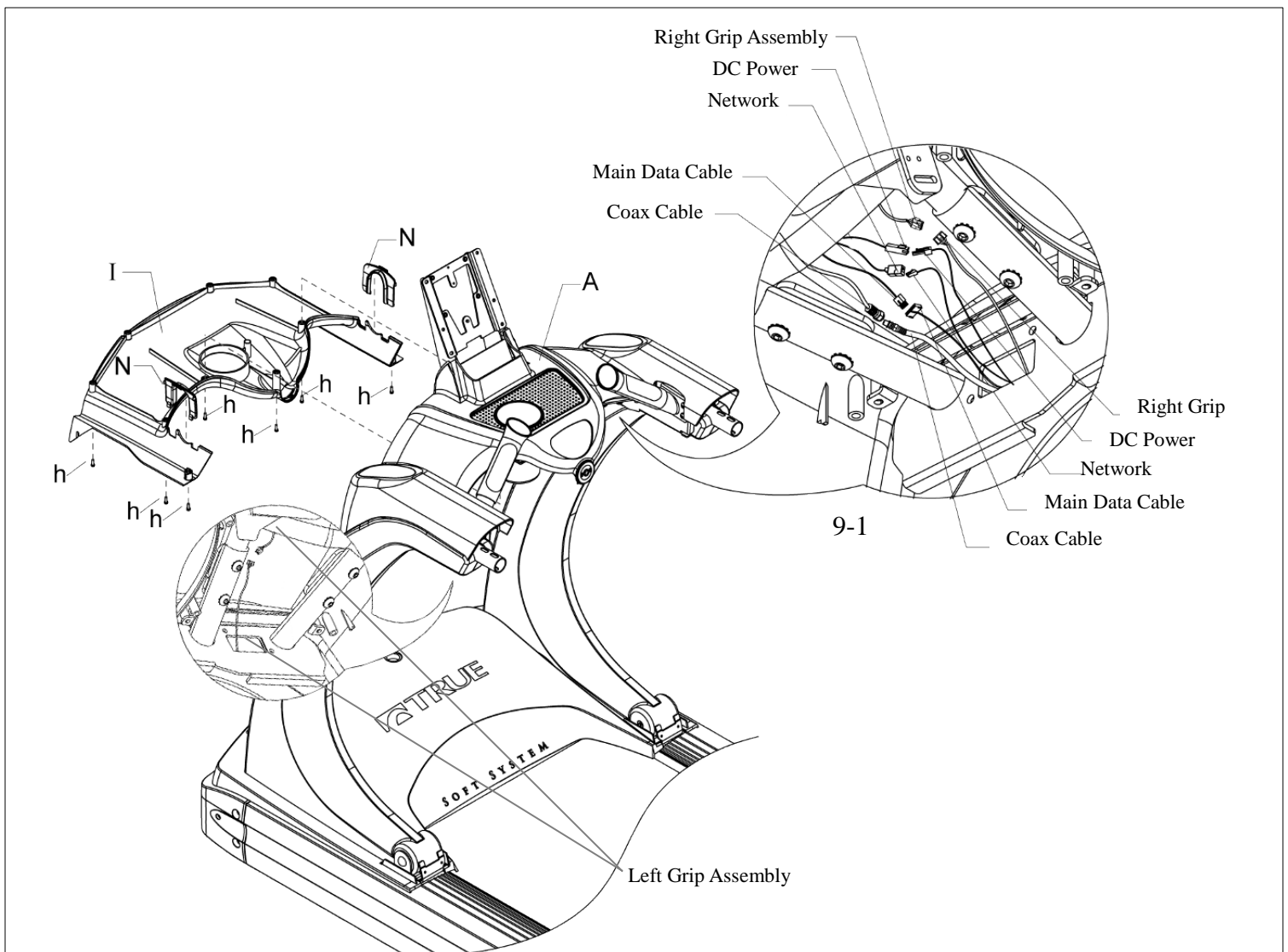

Fig. 8

CHAPTER 2: ASSEMBLY INSTRUCTIONS

TREADMILL ASSEMBLY STEPS (CONTINUED):

Step 9 Handrail & Pivot Trim Installation:

- a) Insert Handrails (E, F) into Pedestals by slightly rotating Handrail and pushing front rubber lip of Handrail under the Pedestal plastic.
- b) Secure Handrails with bolts (g, 2 per side).

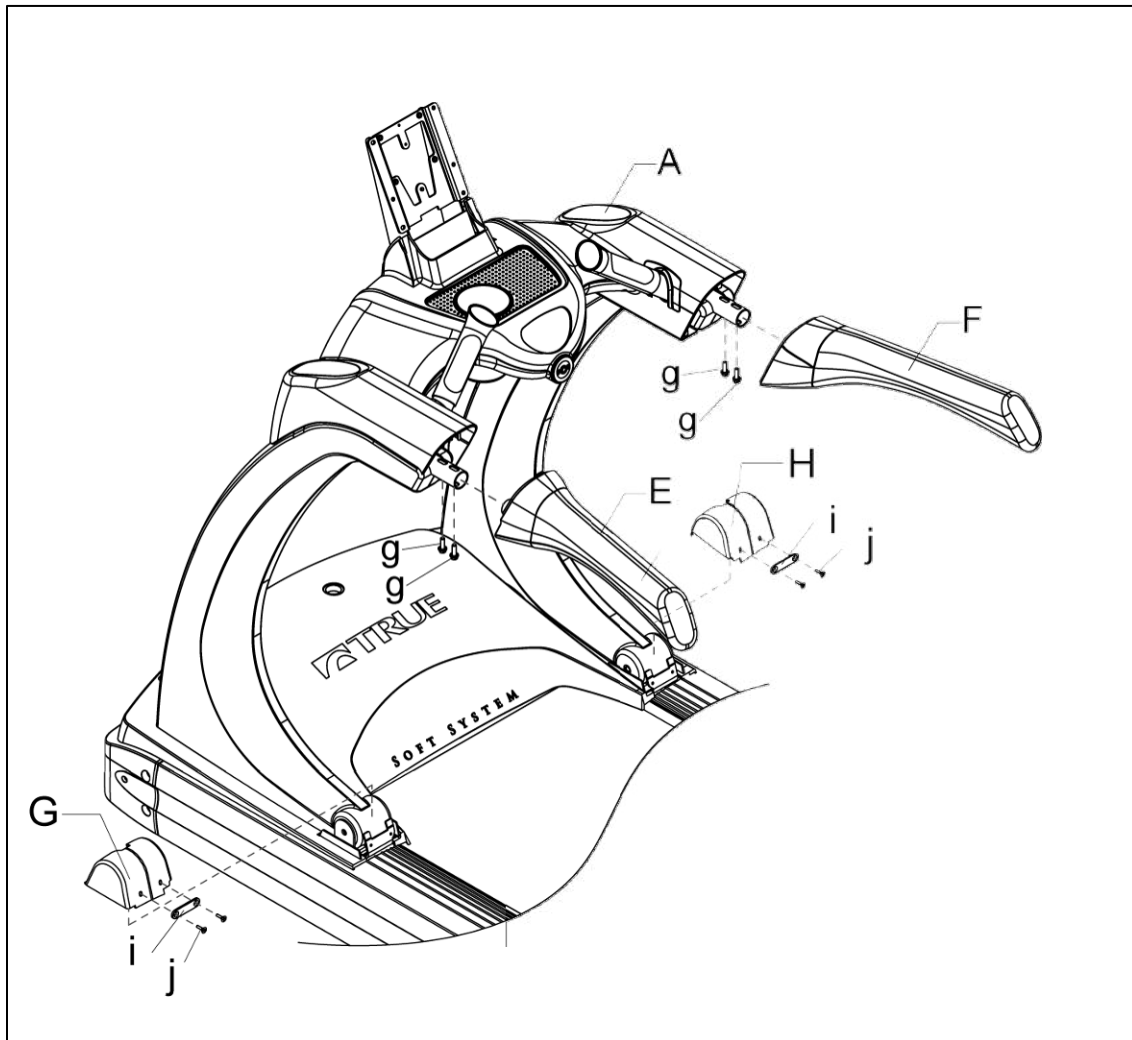

- c) Install Pivot Trim Left & Right (G, H) onto Frame as shown in Fig. 9. Insert front tab of Pivot Trim into Motor Cover side piece and then rotate down to cover pivot. Secure with Strap – Pedestal Trim (i) and two Screws 10-32 (j) using #2 Phillips screwdriver.

CHAPTER 2: ASSEMBLY INSTRUCTIONS

TREADMILL ASSEMBLY STEPS (CONTINUED):

Step 10 Safety Key:

- Safety key and attachment cord are wrapped around plate during shipping.
- Unwind safety key and cord from plate.
- Attach Safety Key magnet to front of console rack as shown below.
- Attach Safety Key clip to plate located on Console Rack (when not working out).
- Attach clip to clothing at the beginning of any workout.

CAUTION: Read treadmill Owner's Manual before attempting any workout

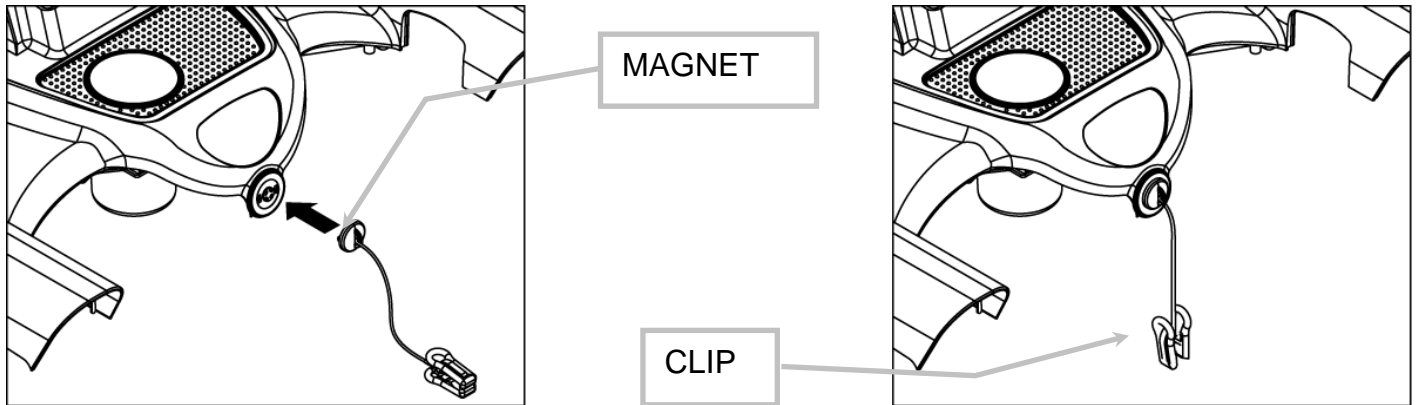

CHAPTER 2: ASSEMBLY INSTRUCTIONS

Step 11 Decline Foot Assembly Installation & Leveling:

- a) Position cardboard from packaging next to side of base unit.
- b) **Using 2 people**, tilt treadmill on one side so that cardboard protects side of unit.
- c) While one person holds treadmill securely in place, the other person must unscrew both rear leveling feet. Place to side for later use. See Fig. 1.
- d) Install two leveling feet on decline foot assembly, with leveling foot with extra jam nut to be placed on the shorter post of decline foot assembly. See Fig 2.
- e) Install Decline Foot Assembly onto existing foot mounts of treadmill frame. Align two grooves in Decline Foot Assembly with two grooves in treadmill frame bottom. They should both be on the left side of the base unit. Ensure that you leave approximately 1/4 inch gap between the jam nut and the base of the decline foot on the right side of the pedestal. See Fig. 3.
- f) Secure with four 1/4-20 x 3/4 hex head bolts included in kit.
- g) **Using 2 people**, carefully tilt treadmill upright.



Fig 1

Fig 2

Fig 3

- h) Ensure treadmill incline rack wheels and rear feet are resting on the floor and not on cardboard, packaging, etc.
- i) Using a 15/16 inch open end wrench, loosen nut A on Right Rear Foot (only side adjustable). Fig. 12-2
- j) Using a level or estimating by sight, turn section B of foot clockwise, or counter-clockwise, using a 7/8 inch open end wrench to level the rear of treadmill.
- k) Tighten nut A until it is secured against bottom of treadmill.

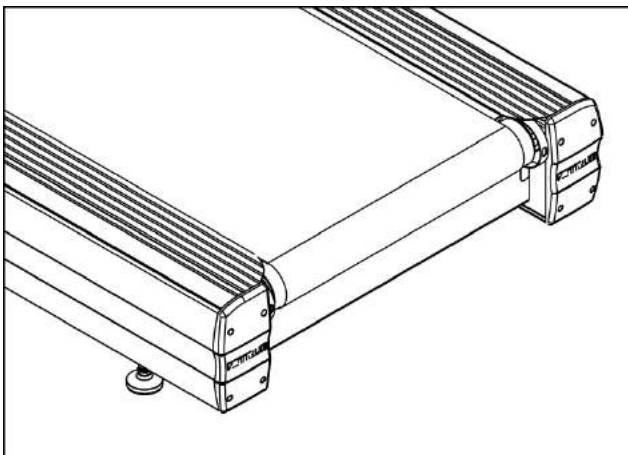

Fig. 12-1

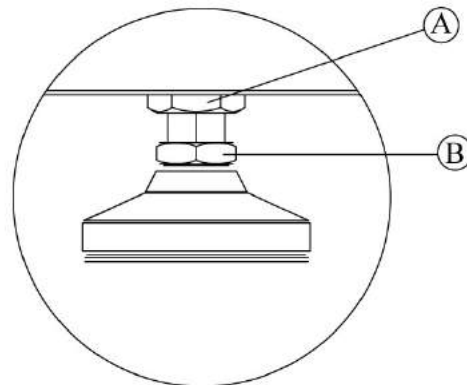

Fig. 12-2

NOTE: The protective film covering the frame sides and front can be removed at this time.

CHAPTER 2: ASSEMBLY INSTRUCTIONS

TREADMILL ASSEMBLY STEPS (CONTINUED):

Step #12A Console Cable Connections:

*Follow Step 12A if installing a touchscreen console or 15" TFT console. For other consoles, proceed to Step 12B.

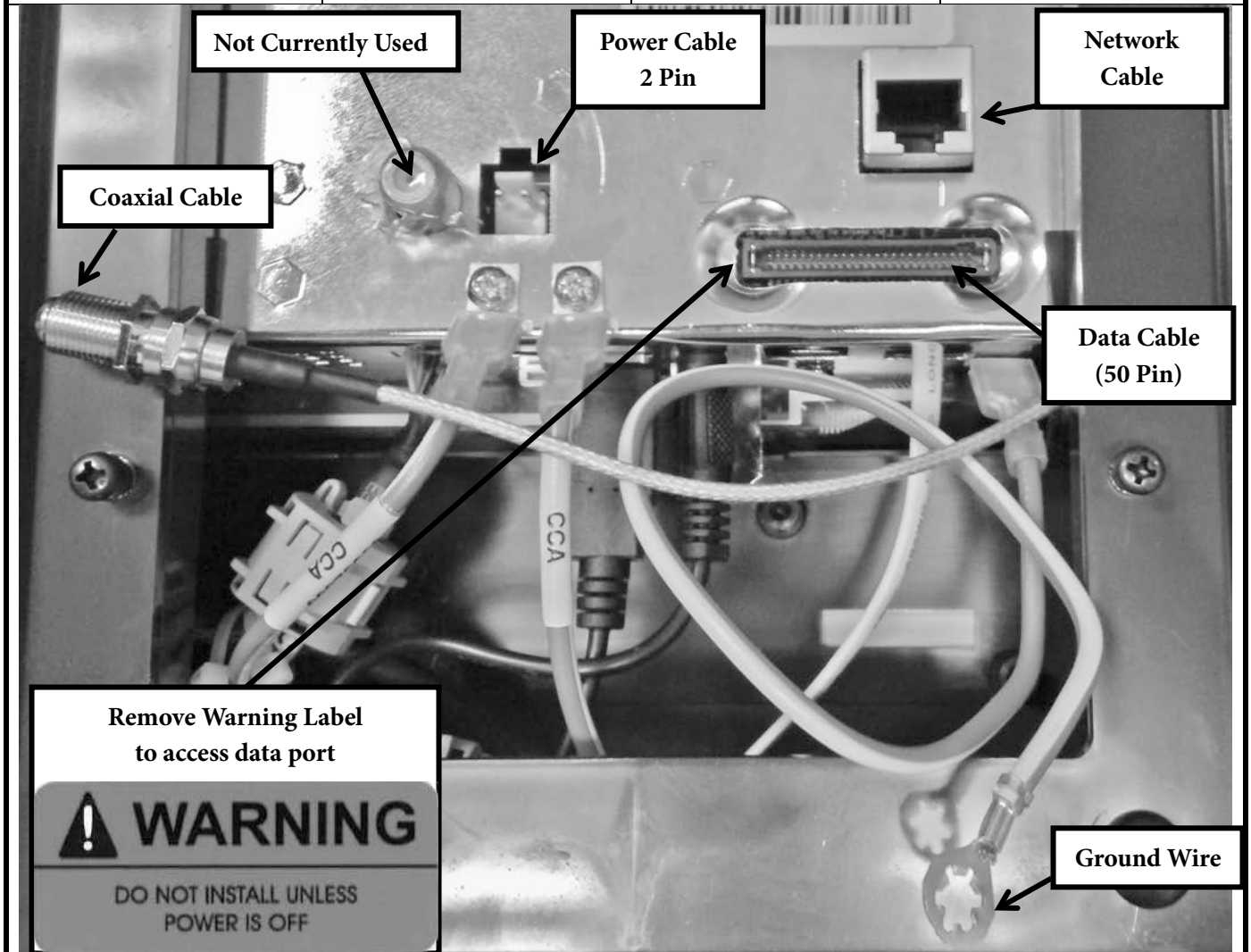

NOTE: Ethernet & Coaxial cable connections are not available on the 9" TFT Consoles
The Ethernet Port on the 15" TFT Console is non-functioning
All Ground Wires Must be connected

CHAPTER 2: ASSEMBLY INSTRUCTIONS

TREADMILL ASSEMBLY STEPS (CONTINUED):

Step #12A Console Cable Connections (continued):

*Follow Step 12A if installing a touchscreen console or 15" TFT console. For other consoles, proceed to Step 12B.

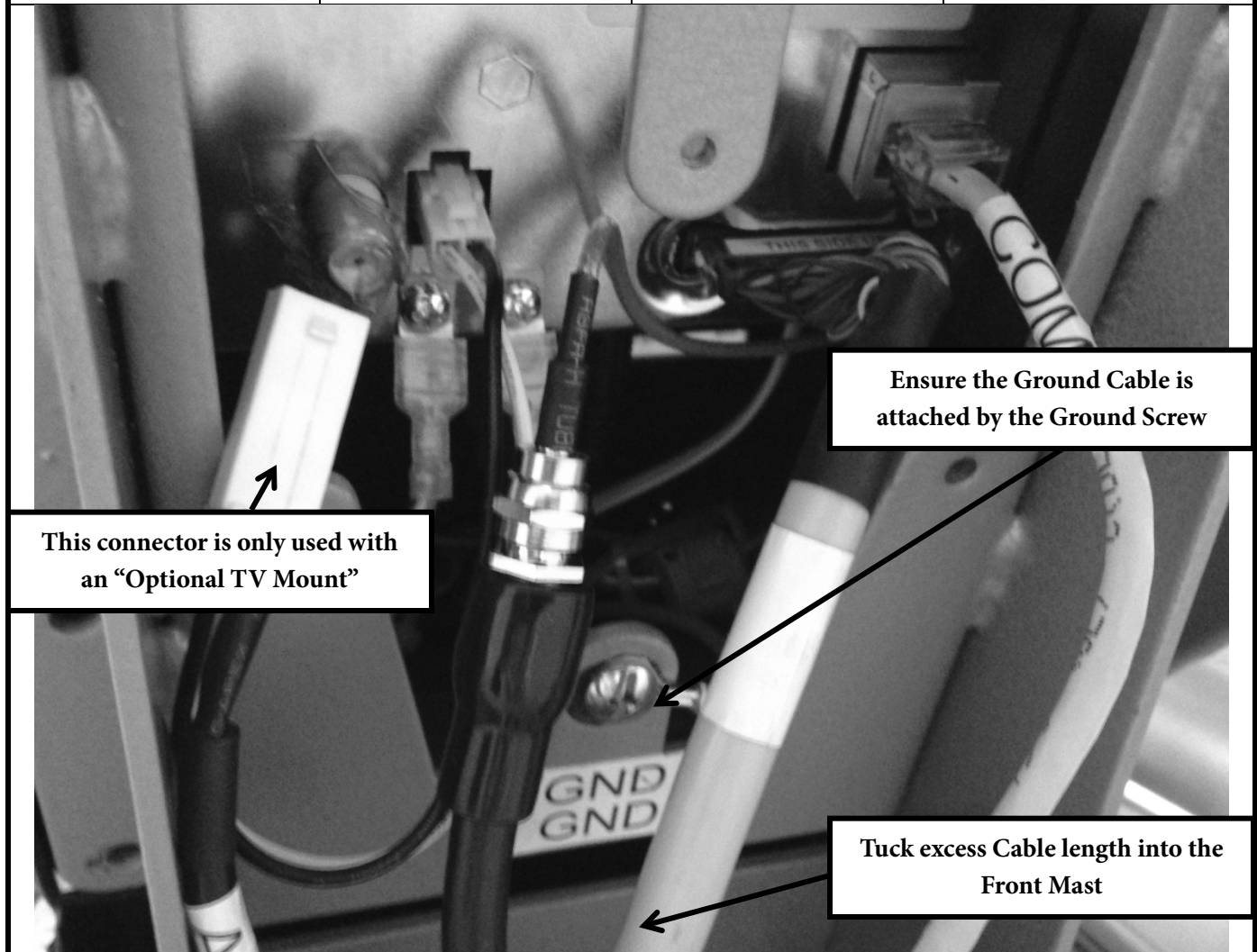

NOTE: Ethernet & Coaxial cable connections are not available on the 9" TFT Consoles
The Ethernet Port on the 15" TFT Console is non-functioning
All Ground Wires Must be connected

CHAPTER 2: ASSEMBLY INSTRUCTIONS

TREADMILL ASSEMBLY STEPS (CONTINUED):

Step 12B Console Cable Connections:

*Follow Step 12B if installing a 9" TFT console or an LED console. For other consoles, return to Step 12A.



9" TFT Console

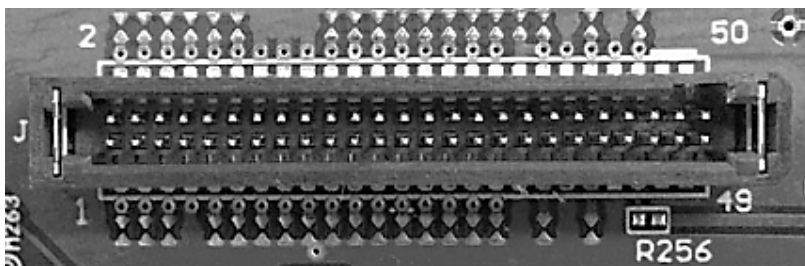

Connect Data Cable (50-pin)

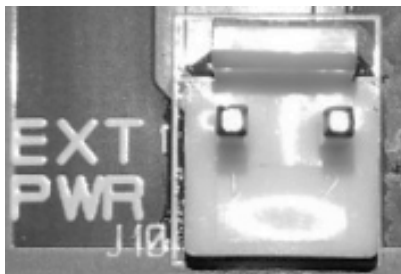

Connect Power Cable (2-pin)

NOTE: Ethernet & Coaxial cable connections are not available on the 9" TFT Consoles
All Ground Wires Must be connected

CHAPTER 2: ASSEMBLY INSTRUCTIONS

TREADMILL ASSEMBLY STEPS (CONTINUED):

Step 13Rear Console Cover Installation:

Once Console is installed, using a Phillips screwdriver, install Rear Console Cover (M) with 3 screws (g)

CAUTION: Make sure cabling is NOT pinched during installation.

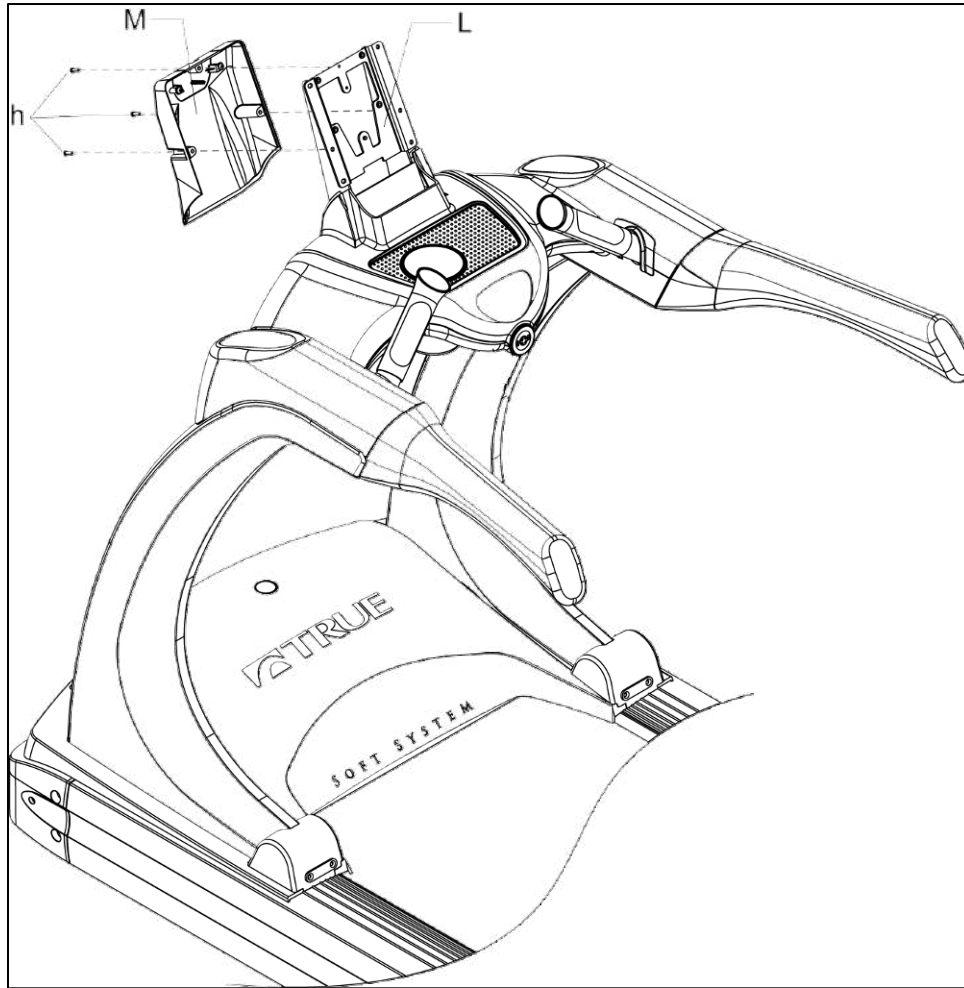

Fig. 13

CHAPTER 2: ASSEMBLY INSTRUCTIONS

TREADMILL ASSEMBLY STEPS (CONTINUED):

Step 14 Power Cord Installation:

- a) Insert Power Cord into Power Inlet receptacle of front electrical panel of treadmill. See Fig. 14-1 for location.
- b) b. Install Spacer (k), Retainer - Power Cord (l), and screw (m) as shown in Fig. 14-1 but do not tighten.
- c) c. Rotate power cord retainer down and tighten screw to push retainer up against Power Cord.

See Fig. 14-1.

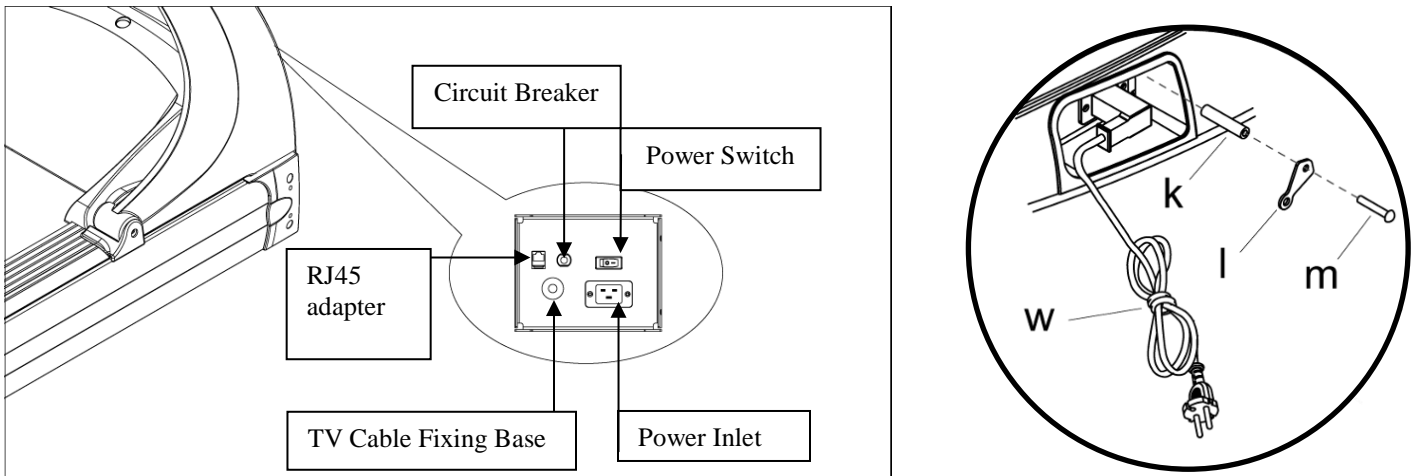
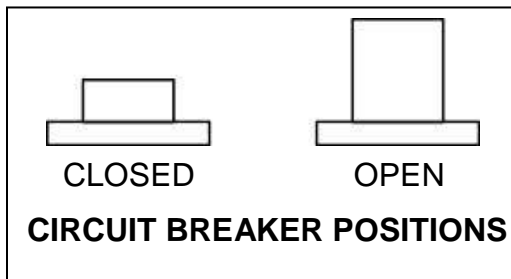

Fig. 14-1: ES900 Treadmill Front Electrical Panel

POWER SWITCH: 1 = ON, 0 = OFF

CIRCUIT BREAKER: In the event the current drawn by the treadmill exceeds a specified threshold value, the Circuit Breaker will operate; the button will pop out, and open the circuit. If this should occur, please wait 10 minutes and then reset the Circuit Breaker by pressing the button in on Circuit Breaker. If it does not reset, or the Circuit Breaker operates again, please contact True Fitness Service department at 1-800-883-8783.



CHAPTER 2: ASSEMBLY INSTRUCTIONS

TREADMILL ASSEMBLY STEPS (CONTINUED):

Wiring Schematic:

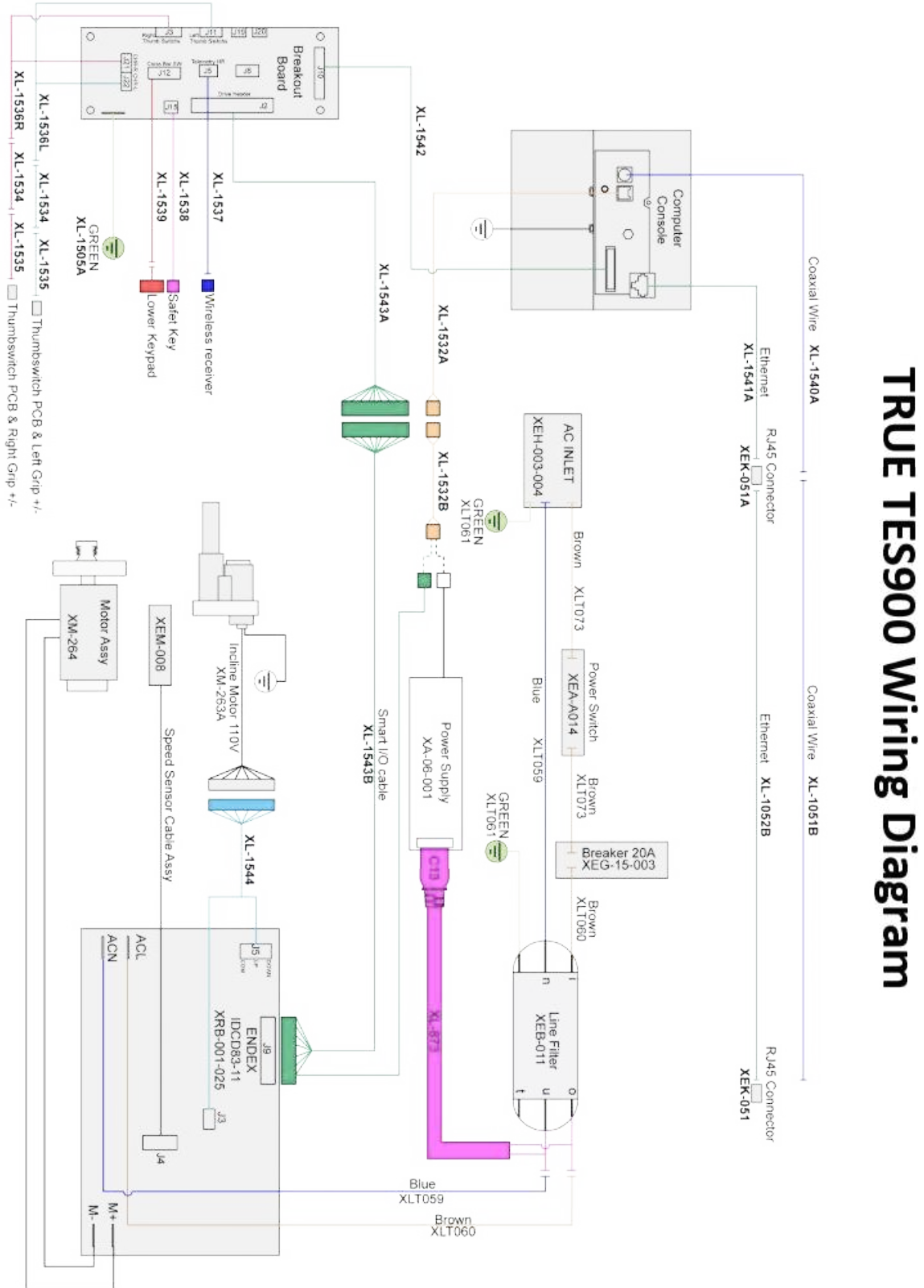

CHAPTER 3: PRODUCT OVERVIEW

TREADMILL OVERVIEW:



CHAPTER 3: PRODUCT OVERVIEW

TREADMILL OVERVIEW (CONTINUED):

Console Assembly:

The console allows the user to set up a workout program and control the treadmill during a workout (For console overview and operation instructions refer to chapter 4).

Quick Access Keys:

Allows the user to quickly start, stop and wake the treadmill or make fast, convenient adjustments to the incline level or speed of the treadmill.

Contact Heart Rate Pads:

Allows the user to check their heart rate without wearing a wireless chest strap.

*For increased safety and accuracy this feature should only be used when the belt speed is below 4 mph.

Safety (E-Stop) Key:

A tethered safety device designed to attach to both the user and the treadmill console. Removal of the key from the console will stop belt motion to prevent injury in an emergency.

*The safety key must be in place on the treadmill, and should be attached to the user's clothing. The treadmill will not operate if the safety key is not attached to the treadmill.

Belt:

The moving surface of the treadmill on which the user walks or runs.

Straddle Covers:

Stationary covers on either side of the belt, which allows the user to safely straddle the belt during startup or in the event of an emergency.

Belt Adjustment Bolts:

An adjustment system that allows the users to adjust the belt tracking and tension as needed.

On/Off Switch:

Allows users or faculty to turn the power on or off to the treadmill.

Circuit Breaker:

A safety device designed to protect the treadmill from excessive electrical current.

Power Cord:

Delivers power from the wall outlet to the treadmill.

Decline Foot and Leveling Feet:

The decline foot allows the treadmill to decline so the user can enjoy the benefits of a downhill workout. The leveling feet are an adjustable system used to aid in the leveling the treadmill.

Adjustable Soft Select:

Allows users to "personalize" the walking surface from soft to firm or anywhere in between.

CHAPTER 4: PROGRAMMING & OPERATION

▲ CAUTION:

The safety key must be in place on the treadmill console, and should be attached to the user's clothing. The treadmill will not operate if the safety key is not attached to the console.

HEART RATE MONITORING:

This treadmill can monitor a user's heart rate using either a Polar® compatible chest strap or the metal grips on the hand rails (called contact heart rate or CHR pads). A chest strap transmits the user's heart rate to the treadmill via radio, and the CHR pads connect to a special computer circuit to extract the user's heart rate.

Chest Strap Heart Rate Monitoring:

Although this treadmill functions fine without using the heart rate monitoring feature, this kind of monitoring gives valuable feedback on the user's effort level. Chest strap monitoring also allows users to use Heart Rate Control, the most advanced exercise control system available.

When users wear a Polar® compatible transmitter strap, the treadmill will display the user's heart rate as a digital beats-per-minute (bpm) readout.

The transmitter strap should be worn directly against the user's skin, about 1-2 inches below the pectoral muscles/breast line. Women should be careful to place the transmitter below their bra line.

Initially the transmission signal for heart rate may be erratic or non-existent. Some moisture is necessary between the strap and the user's skin for proper transmission. Sweat from exercise works best, but ordinary tap water may be used prior to the workout if desired.



A Note on Chest Strap Heart Rate Monitoring:

The chest strap produces a radio signal that the treadmill reads and registers as the user's heart rate. The accuracy of a reading may be affected when outside interference is present.

Contact Heart Rate (CHR):

The CHR system will let the user monitor their heart rate without wearing a chest strap. When using the CHR system users should gently grasp the CHR pads with both hands. Within 30 seconds, the user's heart rate should be displayed as a digital bpm readout (during the first 30 seconds the system is analyzing and locking in the user's heart rate). Users should exercise with smooth body motions and breathe regularly. It is best to avoid talking while using the CHR system, as talking will cause unrepresentative heart rate spikes of 5 to 10 bpm. To ensure an accurate reading, the user's hands should be clean, free of both dirt and hand lotions.

*For increased safety and accuracy the CHR system should only be used at speeds of 4 mph or lower (CHR readings are less accurate due to large muscle movements above this speed).

A Note on CHR Accuracy:

CHR monitoring may be less accurate than chest strap monitoring since the heart rate signals are much stronger at the chest. When using a HRC workout, it is best to use a chest strap because of the stronger and more accurate readings.

▲ CAUTION:

Do not use the contact heart rate grips as a handlebar during a workout.

CHAPTER 4: PROGRAMMING & OPERATION

HEART RATE CONTROL (HRC):

Introduction:

You are now the owner of the most sophisticated Heart Rate Control treadmill available. TRUE HRC is unique and patented. It accommodates users from rehabilitation to world class athletes, and all those in between. TRUE HRC allows users to do a completely hands free heart rate controlled workout using speed, incline or both. By training at a specific target heart rate, users can exercise at a more efficient cardiovascular level.

The TRUE HRC system is unique because users must enter the key parameters of the workout; target heart rate, maximum speed, maximum incline, and time, prior to beginning the HRC workout. As users approach their target heart rate, the treadmill's computer automatically takes over and changes the speed and/or incline automatically to keep users near their target heart rate. This allows for a completely "hands free" workout.

*A Polar® compatible heart rate monitoring chest strap should be worn during HRC workouts. For increased safety and accuracy, contact heart rate monitoring is not recommended for HRC workouts.

Target Heart Rate:

TRUE's heart rate control (HRC) workouts let the treadmill monitor relative exercise intensity by way of the user's heart rate, then automatically adjust the speed and incline to keep the user at their target heart rate and thus their desired exercise intensity. Heart rate is a good measure of the body's exercise stress level. It reflects differences in physical condition, fatigue, the comfort of the workout environment, even diet and emotional state. Users should compare their heart rate with how they feel to ensure safety and comfort.

Consult a physician to determine target heart rate:

Using heart rate to control a workout takes the guesswork out of the workout settings. Consult a physician before using heart rate controlled workouts for advice on selecting a target heart rate range. Also, it is important to use the treadmill for several workouts in the manual mode while monitoring heart rate. Users should compare their heart rate with how they feel to ensure safety and comfort. After users have spent some time learning how their heart responds to different levels of speed and incline, they will have a better understanding of how to select the maximum speed and maximum incline required for reaching their target heart rate.

Warm Up:

At the beginning of an HRC workout, the treadmill is in full Manual Control mode. Users should gradually increase the workout intensity to slowly raise their heart rate to within 10 beats per minute (bpm) of their target heart rate. The treadmill will operate as if in manual mode during the warm up stage. Users control both speed and incline. The user may only increase speed and incline to the present maximum values entered. It is important that the user starts at a low level of perceived exertion and gradually increase the workout intensity over several minutes until they approach their target heart rate. This allows the body to adapt to the workout. Increasing the workout intensity gradually will allow the user to enter the heart rate control stage without overshooting their target, keeping their heart rate within a few bpm of their target.

*Warming up too fast may cause the user to overshoot their target. If this occurs it may take several minutes before the computer software can control their heart rate. Users may overshoot and undershoot for several minutes until control is achieved.

CHAPTER 4: PROGRAMMING & OPERATION

HEART RATE CONTROL (CONTINUED):

Heart Rate Control Stage:





The treadmill takes control of speed and incline, keeping the user's heart rate within a few bpm of their target. When using the Interval HRC Workout, the treadmill alternates between work and rest intervals.

Cool-Down:

At the end of the workout time or distance, the treadmill reduces the workout intensity by half and goes back into Manual Control mode, where users directly control their cool-down.

PROGRAM DESCRIPTIONS:

Available programs vary depending on the console option selected. Please refer to the chart to the below for assistance in determining which programs are available on this unit.

Console Options	 Transcend ¹⁶	 Transcend ¹⁰	 Escalate ¹⁵	 Escalate ⁹
***	YES	YES	YES	YES
**	YES	YES	YES	
*	YES	YES		

Quick Start: ***

A workout in which the user controls all settings. The workout continues until it is ended by the user.

Manual: ***

Users enter their weight, workout time or distance. The user controls both the SPEED and INCLINE of the treadmill throughout the workout.

Hill Intervals: ***

Hill Intervals makes changes to the INCLINE in 2-minute segments with the SPEED remaining constant. Users can make adjustments to the SPEED during the workout. SPEED changes are permanent; INCLINE changes affect the current 2-minute segment only.

CHAPTER 4: PROGRAMMING & OPERATION

PROGRAM DESCRIPTIONS (CONTINUED):

Rolling Hills: ***

Series of gradually increasing and decreasing INCLINE changes that simulate rolling hills. Users can make adjustments to the SPEED during the workout. SPEED changes are permanent; INCLINE changes affect the current segment only.

Single Hill: ***

INCLINE increases to a maximum at the mid-point of the workout, then decreases to the finish. Users can make adjustments to the SPEED during the workout. SPEED changes are permanent; INCLINE changes affect the current segment only.

Weight Loss Hills: ***

2-minute WALKING interval segments with INCLINE alternating between hills and a nearly flat landscape. Users can make adjustments to the SPEED during the workout. SPEED changes are permanent; INCLINE changes affect the current segment only.

Glute Buster: ***

A changing INCLINE profile simulates hilly terrain to promote intense glute muscle use. Users can make adjustments to the SPEED during the workout. SPEED changes are permanent; INCLINE changes affect the current segment only.

Calorie Goal: ***

This workout allows users to choose the number of calories they wish to burn within a specified workout time. The treadmill will control SPEED and INCLINE within the limits set by the user to attain this goal.

Cardio Challenge: ***

SPEED and INCLINE increase to a maximum at the mid-point of the workout, then decrease to the finish. INCLINE and SPEED changes affect the current segment only.

Walk and Run Intervals: ***

Uses SPEED to create WALKING then RUNNING intervals in 1-minute segments. Users can make adjustments to the INCLINE during the workout. INCLINE changes are permanent; SPEED changes affect the current 1-minute segment only.

Speed Intervals: ***

Walking or running speed intervals that are in 1-minute segments. Users can make adjustments to the INCLINE during the workout. INCLINE changes are permanent; SPEED changes affect the current 1-minute segment only.

Speed Ramp: ***

Speed increases to a maximum at the mid-point of the workout, then decreases to the finish. Users can make adjustments to the INCLINE during the workout. INCLINE changes are permanent; SPEED changes affect the current segment only.

Leg Shaper: ***

SPEED changes in this workout to emphasize the leg muscles with added intensity. Users can make adjustments to the INCLINE during the workout. INCLINE changes are permanent; SPEED changes affect the current segment only.

CHAPTER 4: PROGRAMMING & OPERATION

PROGRAM DESCRIPTIONS (CONTINUED):

Distance Workouts: ***

Choose any one of our 4 common distance workouts - 5k, 10k, 2 mile or 4 mile. The user controls both the SPEED and INCLINE of the treadmill throughout the workout.

Saved Workouts: ***

Access to previously saved manual workouts.

Custom Speed: **

Set up custom SPEED intervals. Up to 30 easy to adjust segments allow users to customize any speed profile.

Custom Incline: **

Build a custom INCLINE profile using up to 30 segments. A user friendly setup screen allows users to create any hill or incline profile.

Custom Ultra: **

If users are having trouble finding a workout that fits their specific needs, try setting up the Custom Ultra! This completely customizable workout setup allows both SPEED and INCLINE control in up to 30 segments.

HRC Cruise Control: ***

While in any program, Cruise Control will allow the user to set current heart rate as target heart rate by pressing a single button. The Cruise Control program takes control of SPEED and INCLINE to maintain the users target Heart Rate. If Beats per Minute exceeds the target by more than 12 BPM the workout will end and Cool Down will begin.

HRC Target: ***

Users choose their target heart rate. The treadmill begins in MANUAL control – The user should gradually increase the workout intensity until heart rate is within 10 bpm of their target. At this point, the treadmill takes over to control speed and incline to maintain heart rate within a few beats of the user's target.

HRC Weight Loss: ***

Based on age, this is a heart rate controlled workout at 65% of the user's maximum heart rate. This creates efficient fat burning without overtraining. The treadmill begins in MANUAL control –The user should gradually increase the workout intensity until their heart rate is within 10 bpm of their target. At this point, the treadmill takes over to control speed and incline to maintain heart rate within a few beats of the user's target.

HRC Aerobic: ***

Based on age, this is a heart rate controlled workout at 80% of the user's maximum heart rate. This keeps the user in the optimum aerobic training range to improve cardio fitness. The treadmill begins in MANUAL control - gradually increase the workout intensity until the user's heart rate is within 10 bpm of their target. At this point, the treadmill takes over to control speed and incline to maintain heart rate within a few beats of the user's target.

CHAPTER 4: PROGRAMMING & OPERATION

PROGRAM DESCRIPTIONS (CONTINUED):

HRC Intervals: ***

Intervals of WORK and REST determined by target heart rate. The treadmill begins in MANUAL control – Users should gradually increase their workout intensity until their heart rate is within 10 bpm of their target. At this point, the treadmill takes over to control speed and incline to maintain the user’s HR within a few beats of their target. The rest segment will reduce to 65% intensity of work segment.

Custom HRC Intervals: **

Set up a custom heart rate interval. Specify WORK and REST targets and let the treadmill make all the adjustments. The treadmill begins in MANUAL control - gradually increase the workout intensity until heart rate is within 10 bpm of the user’s target. At this point, the treadmill takes over to control speed and incline to get the user’s heart rate within a few beats of their target.

HRC Distance Workouts: **

4 popular fixed distance workouts (5k, 10k, 2 miles and 4miles) that put the treadmill in control of pace by selecting the user’s target heart rate. The treadmill begins in MANUAL control - The user should gradually increase the workout intensity until heart rate is within 10 bpm of their target. At this point, the treadmill takes over to control speed and incline to maintain heart rate within a few beats of the user’s target.

Fitness Test: ***

A fitness test uses heart rate to estimate the user’s VO2 max. The test increases SPEED and INCLINE gradually every minute and ends at the point where the user’s heart rate reaches 85% of the maximum for their age.

Air Force fitness Test: **

1.5-mile running test measured against age and gender calculations. Users can make adjustments to the SPEED during the workout.

Navy Fitness Test: **

1.5-mile running test measured against age and gender calculations. Users can make adjustments to the SPEED during the workout.

Army Fitness Test: **

2-mile running test measured against age and gender calculations. Users can make adjustments to the SPEED during the workout.

Marines Fitness Test: **

3-mile running test measured against age and gender calculations. Users can make adjustments to the SPEED during the workout.

CHAPTER 4: PROGRAMMING & OPERATION

VIRTUAL ACTIVE VIDEOS: *

*Content is provided by Virtual Active™ and is subject to change without notice.

Indoor Cycling Group World Tour Northern Italy:

Northern Italy is a cyclist's dream, where stunning views meet tough terrain. The rugged cliffs along Italy's largest lake, Lago di Garda are just a short ride away from the idyllic small town of Pregasina, and the rural mountain passes of Gampenjoch are as beautiful as they are treacherous. Enjoy one advanced hill climb, and one endurance-focused ride with mixed terrain.

Destinations Include:

- Sentiero Ponale, Lago di Garda, Veneto
- Pregasina, Lago di Garda, Veneto
- Località Viote, Lago di Garda, Trento
- Ötztal Alps, Bolzano-Bozen
- Penser Joch, Bolzano, South Tyrol
- Gampenjoch, Bolzano, South Tyrol



Chicago Run:

Explore the tall buildings and wide public parks of this Midwestern metropolis. From the sculpture gardens of Millennium Park, to the shores of Lake Michigan, to the shops that line the Magnificent Mile, the Windy City boasts spectacular sights. The guided workout is speed-focused, and includes two challenging sprints.

Destinations Include:

- Grant Park
- The Magnificent Mile
- Lake Michigan
- Chicago River Walk



Germany Run:

Run the Rhineland, from the thick forests of Thuringia to the Gothic spires of Nuremburg. This lively mix of urban and natural courses includes a jaunt past the waterfalls that decorate the Wimbachklamm gorge and a visit to Munich's bustling plaza, Marienplatz, in the heart of Bavaria. The guided workout alternates speed challenges and recovery intervals.

Destinations Include:

- Thuringian Forest, Thuringia
- Berchtesgaden National Park, Bavaria
- Berchtesgadener Land, Bavaria
- Munich, Bavaria
- Nuremburg, Bavaria



CHAPTER 4: PROGRAMMING & OPERATION

VIRTUAL ACTIVE VIDEOS (CONTINUED):

American Southwest 2 Run:

Return to the crimson cliffs of the Southwest. Scale Angel's Landing in Zion National Park in Utah, surf "The Wave" in Arizona, and go all-in, with a sprint down the fabulous Las Vegas Strip in Nevada. The guided workout begins with a quick build and maintains a strong pace throughout.

Destinations Include:

- Zion National Park, Utah
- Vermilion Cliffs National Monument, Utah
- Vermilion Cliffs National Monument, Arizona
- Las Vegas, Nevada



Wild California Run:

Explore California's Sierra Nevada mountain range, home to the awe-inspiring domes and waterfalls of Yosemite National Park, and General Sherman, the world's largest tree. The guided workout starts with a challenging climb to the top of Morro Rock, before relaxing into a moderately difficult finish.

Destinations Include:

- Sequoia National Park, California
- Yosemite National Park, California
- Sequoia National Forest, California



Trinity Mountains Hike:

The northwestern corner of California is home to the Shasta-Trinity Mountains, a rugged region of remote beaches, and thunderous herds of Roosevelt elk. Marvel at the magnificent giant sequoias on the Boy Scout Tree Trail and climb to the eerie edge of Devil's Punch Bowl. The guided workout is front-loaded with climbs and back-loaded with speed.

Destinations Include:

- Siskiyou Wilderness
- Jedidiah Smith Redwoods State Park
- Castle Crags State Park
- Prairie Creek Redwoods State Park
- Prairie Creek Redwoods State Park
- Shasta-Trinity National Forest



CHAPTER 4A: TRANSCEND OPERATION

TRANSCEND OVERVIEW:

Touchscreen Display

Cooling Fan



Auxiliary LCD
Display

USB Jack

Headphone Jack

Warning Decal

iPod® Connector

Reading Rack



CHAPTER 4A: TRANSCEND OPERATION

CONSOLE OVERVIEW (CONTINUED):

Touchscreen Display:

A capacitive touchscreen used for workout control and feature navigation.

iPod® Connector:

Standard 30 pin iPod connector used to connect an iPod to the console.

Headphone Jack:

Standard 3.5mm audio jack used to connect headphones to the console during media playback.

USB Jack:

Auxiliary LCD Display:

Displays workout data that can be easily viewed regardless of which mode is displayed on the Touchscreen Display.

*Available on the 16" model only.

Reading Rack:

This ledge on the console can be used to hold a book, magazine, e-reader, or tablet computer during a workout.

Cooling Fan:

Integrated fan that delivers a cooling flow of air during a workout.

Warning Decal:

Important safety information for users to review prior to using the equipment.

CHAPTER 4A: TRANSCEND OPERATION

TOUCHSCREEN INTRODUCTION:

The Transcend Console utilizes a fully integrated capacitive touch screen display and a multi-screen interface to provide a state of the art and user friendly workout.











Capacitive touchscreen technology relies on the conductive properties of the human body to detect when and where on the display the user is touching. Because of this, capacitive touchscreens are highly responsive and do not require pressure to register a touch.

TOUCHSCREEN NAVIGATION:

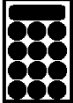
TRUE recommends that users familiarize themselves with the different screens to ensure that they are safely taking advantage of all of the features that this equipment has to offer.

Icon Character Map

This console uses several icons to provide users with a simplified and visually appealing workout experience. The character map below is a quick reference of commonly used icons:

	Incline		Speed
	Cool Down		Toolbox
	Fan Icon		Keypad
	Screen Toggle		Home
	iPod®/Audio Device		Virtual Active®
	TV		NetPulse®

CHAPTER 4A: TRANSCEND OPERATION

TOUCHSCREEN NAVIGATION (CONTINUED):

Home Screen:

The Home Screen is displayed on the console when there is no workout in progress. From this screen the user is able to select from various options to begin a workout or view media.

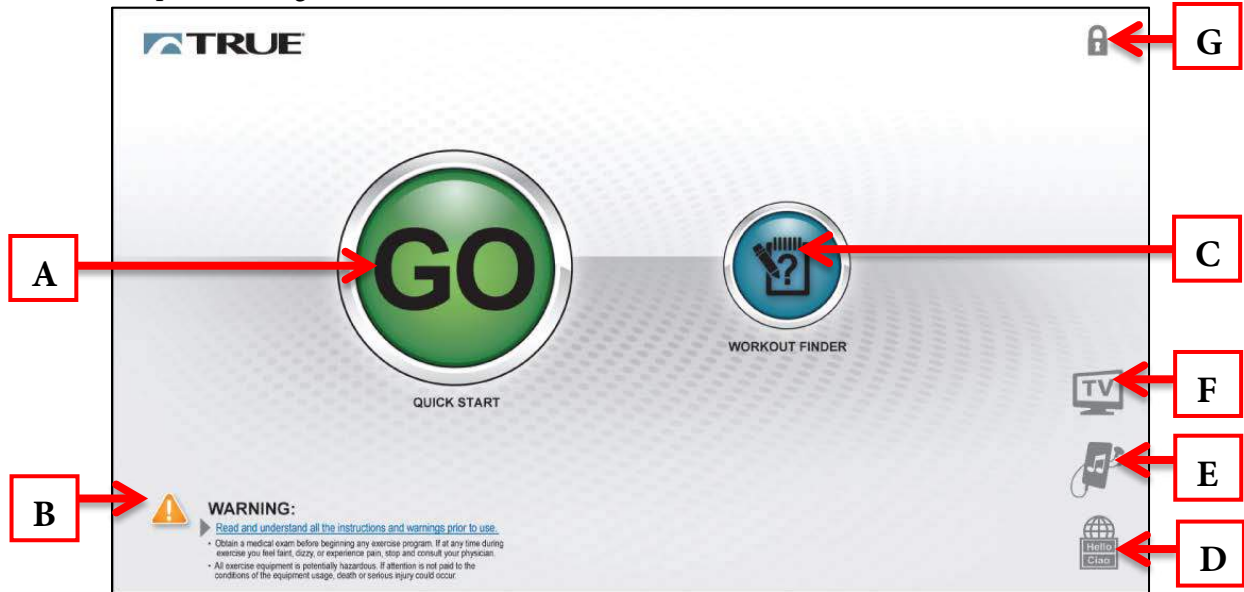

A) Quick Start

Starts a Quick Start workout in which the user controls all settings. The workout continues until it is ended by the user.

B) Safety Instructions

Displays a list of safety instructions for users to review prior to beginning a workout.

C) Workout Finder

Displays preset workouts categorized by goal focus categories.

D) Language Options

Allows users to choose between 12 language options.

E) iPod®/Audio Device

Displays the iPod®/Audio Device interface without starting a workout.

F) TV

Displays TV interface without starting a workout.

G) Screen Lock

When the screen lock is held for 3 seconds, the touchscreen display will lock for 20 seconds to allow for cleaning.

CHAPTER 4A: TRANSCEND OPERATION

TOUCHSCREEN NAVIGATION (CONTINUED):

Selecting a Preset Workout:

Preset workouts are accessed by touching the Workout Finder Button on the home screen. Workouts are organized into 5 categories. To view the workouts in a category simply touch a Category Selection button (A) or swipe through categories in the category preview window (B). Workouts can also be viewed in an uncategorized list by touching the Show All Workouts button (C).

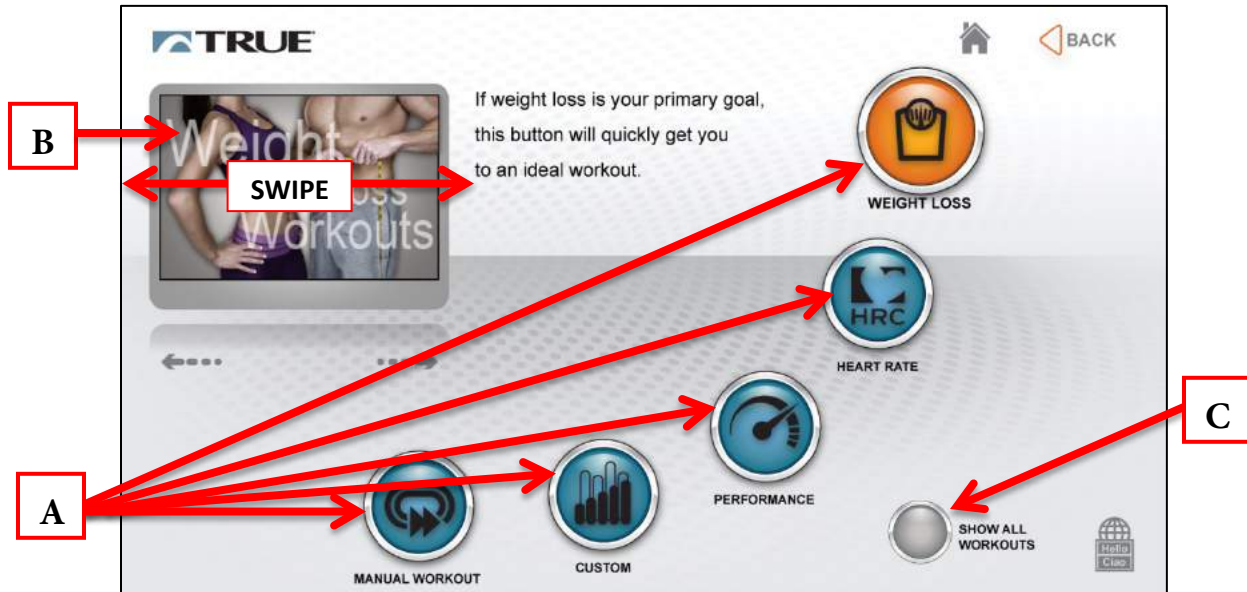

Workout Data Entry Screens:

Workout data entry screens allow the user to input their personal information or workout goals prior to beginning a preset workout. To set a value, touch the heading (A) of the value and adjust the slider (B) to the desired setting or manually enter a value using the keypad (C).

*Workout Data Entry Screens vary by program selection.

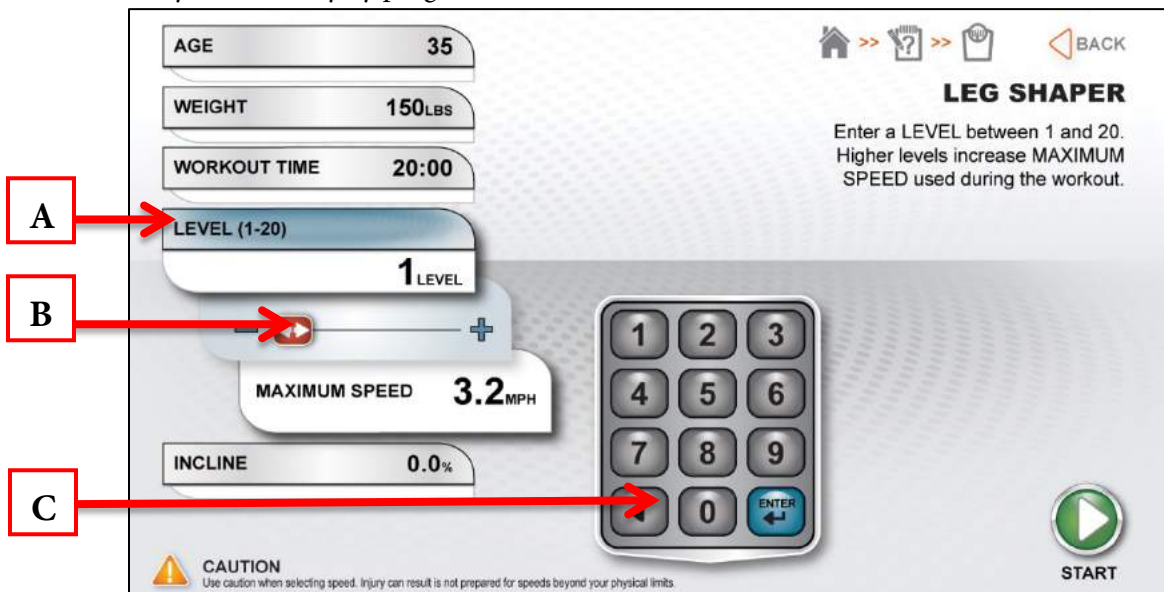

CHAPTER 4A: TRANSCEND OPERATION

TOUCHSCREEN NAVIGATION (CONTINUED):

Workout View Screens:

During any workout a Workout View Screen will be displayed to give the user a comprehensive visual overview of their current workout data.

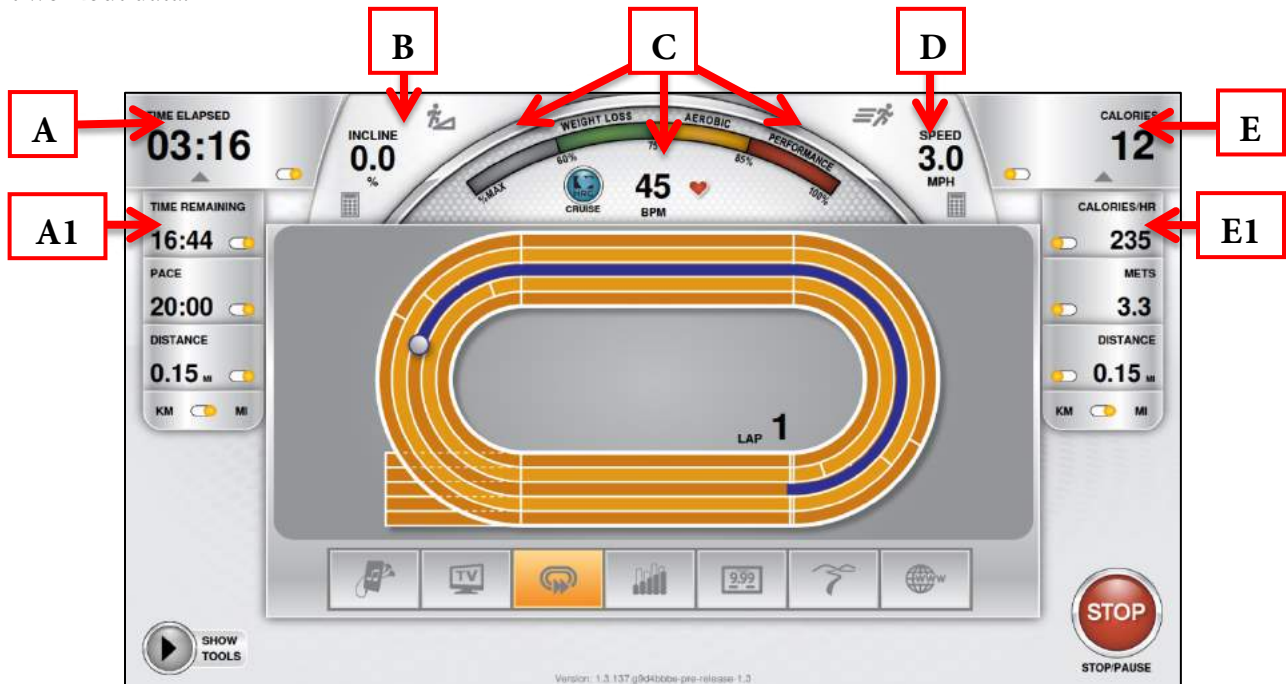

A) Custom Data Display #1:

This display will toggle between data points throughout the workout. To select which data points are displayed, press the arrow below the Data Display to open the Selection Toolbox (A1)

B) Incline:

Displays the current incline level.

C) Heart Rate Information:

When the user is wearing a heart rate chest strap or utilizing the contact heart rate system, their heart rate will be displayed in beats per minute (bpm) and in the graphic meter. The graphic meter is based on age and will gauge the user's approximate heart rate within 3 target levels; Weight Loss, Aerobic or Performance.

D) Speed:

Displays the current speed of the treadmill belt.

E) Custom Data Display #2:

This display will toggle between data points throughout the workout. To select which data points are displayed, press the arrow below the Data Display to open the Selection Toolbox (E1)

CHAPTER 4A: TRANSCEND OPERATION

TOUCHSCREEN NAVIGATION (CONTINUED):

Workout View Screen Controls:

The Workout View Screens contain controls that allow users to adjust settings during their workout

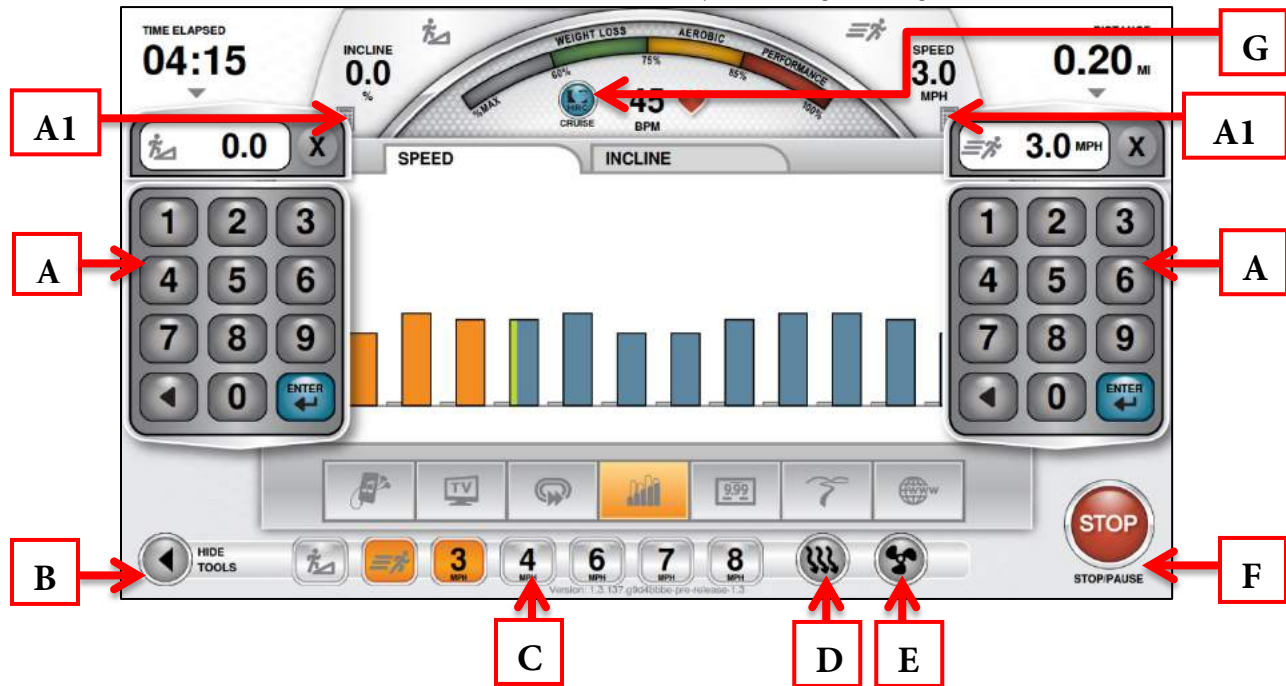

A) Incline/Speed Adjustment Keypads:

These keypads allow the user to input a manual speed or inline adjustments. Touching the Keypad Icons (A1) will open these keypads

C) Quick Keys:

These keys are displayed by touching the Show/Hide button (B) and allow the user to quickly switch between preset speeds or incline levels.

D) Cool Down:

This button is displayed by touching the Show/Hide Tools button (B) and allows the user to end their current workout with a two minute low intensity cool down period. When Cool Down is activated the unit is in manual mode and the user directly controls all settings.

E) Fan On/Off:

This button is displayed by touching the Show/Hide Tools button (B) and turns the cooling fan on or off.

F) Stop:

Stops or pauses the current workout.

G) HRC Cruise Control:

Engages Heart Rate Control to allow the equipment to maintain the user's current heart rate through automatic speed and incline adjustments (when the user is utilizing heart rate monitoring).

CHAPTER 4A: TRANSCEND OPERATION

TOUCHSCREEN NAVIGATION (CONTINUED):

Switching Between Workout View Screens:

There are several Workout Data Screens available to choose from. To switch between screens the user can touch the selection button (A) for the specific Workout Data Screen they wish to use or simply swipe their finger across the main display window (B) to scroll through the available screens.

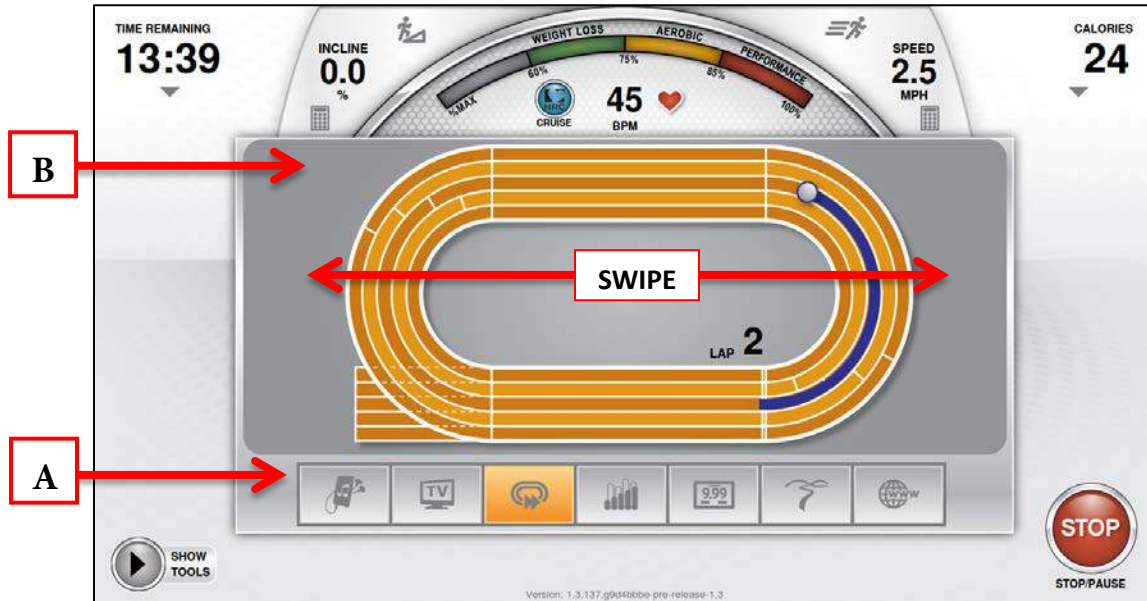

Workout Summary Screen:

At the end of a workout the Summary Screen will display an overview of the workout data. The workout data can be exported to a USB drive by inserting the USB drive into the console's USB port and touching the Save button (A). If the user requires more time to view the summary or to save the workout to a USB device, they can touch the timer (B) to extend the time that the summary remains on the screen.

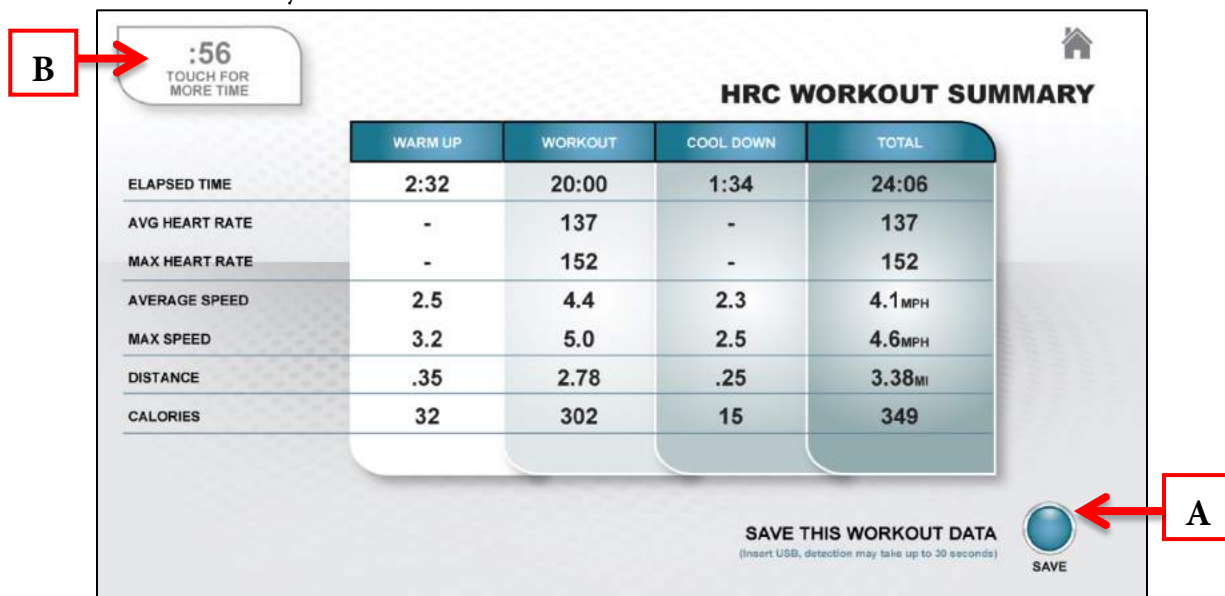

CHAPTER 4A: TRANSCEND OPERATION

WEB BROWSER:

When enabled, the integrated web browser allows users to catch up on breaking news, watch sports highlights, check email and connect with their friends on social media. Having this feature built into a Workout Data Screen allows users to easily multi task.

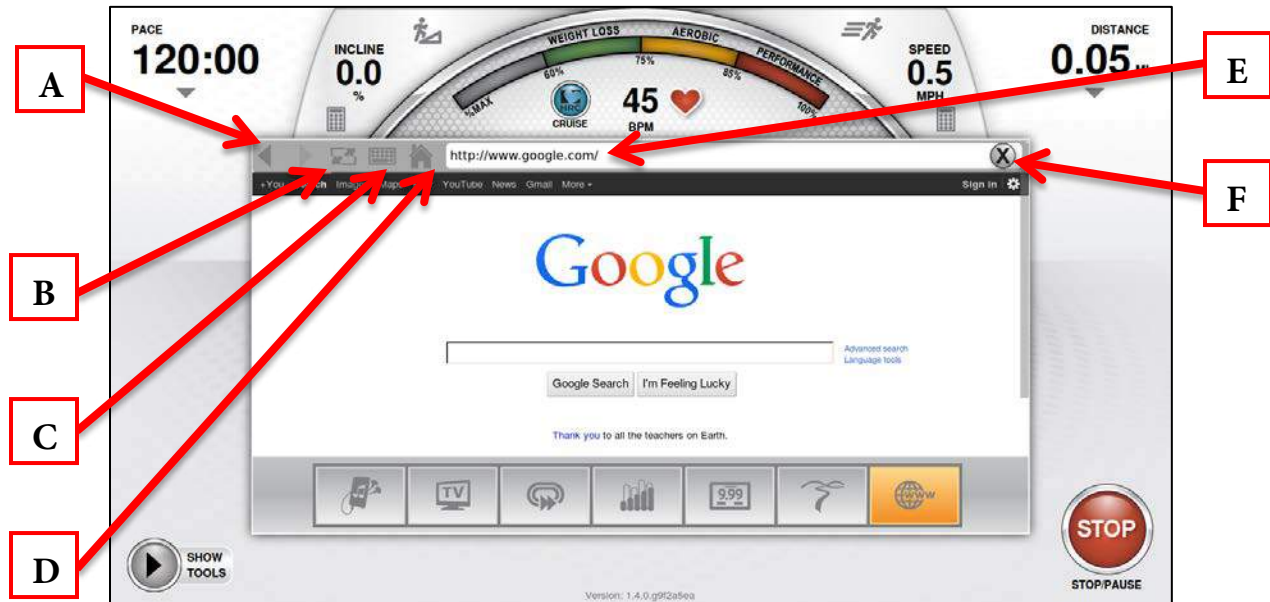

A) Navigation Buttons:

Move forward or backward to the previous page displayed

B) Screen Toggle:

Allows the user to switch back and forth between full screen and regular mode.

C) Keyboard:

Displays the onscreen keyboard to allow users to input text.

D) Home:

Displays the browsers home page.

*See advanced console options for instructions on setting the homepage.

E) Address Bar:

Displays the web address of the page that is being displayed and allows users to input the addresses of pages they wish to visit.

F) Clear Address:

Clears the web address of the page currently being displayed to allow users to input the address of the page they wish to visit.

CHAPTER 4A: TRANSCEND OPERATION

IPOD® INTEGRATION:

The Transcend console has an advanced iPod® Integration feature which allows a user to connect their iPod® to the console via the 30 pin connector located on the front of the console. Once connected, the user can control the functions of their iPod® through the user friendly touchscreen interface.



A) Volume Controls:

Increases, Decreases or Mutes the audio volume from the iPod®.

B) Change Audio:

Toggles between available audio sources.

C) Navigation Buttons:

Allows the user to Play, Pause or Skip media and navigate the iPod® menu.

D) Menu Button:

When pressed, the menu button will return to the previous iPod® menu



CHAPTER 4A: TRANSCEND OPERATION

BLUETOOTH AUDIO:

This console has integrated Bluetooth support for non-30 Pin iPod® audio devices. To pair a device with the console, touch the iPod®/Audio Device Selection Button (A). Ensure that the device is discoverable via Bluetooth and press the Bluetooth Button (B) to search for devices.



The console will complete a scan for available Bluetooth devices. Once the scan is complete, simply touch the name of the desired device (C) to begin the pairing process.

*If the device is not listed, verify that it the Bluetooth is enabled and that the device is discoverable. Then touch the Bluetooth logo (D) to re-scan for the Bluetooth devices.



CHAPTER 4A: TRANSCEND OPERATION

BLUETOOTH AUDIO (CONTINUED):

When a device is selected from the list, the console will send a pairing request to that device. The pairing request must be accepted in order for this feature to operate. For iOS devices, press Pair (E) to accept the request. For Android devices, press Accept (F) to accept the request.

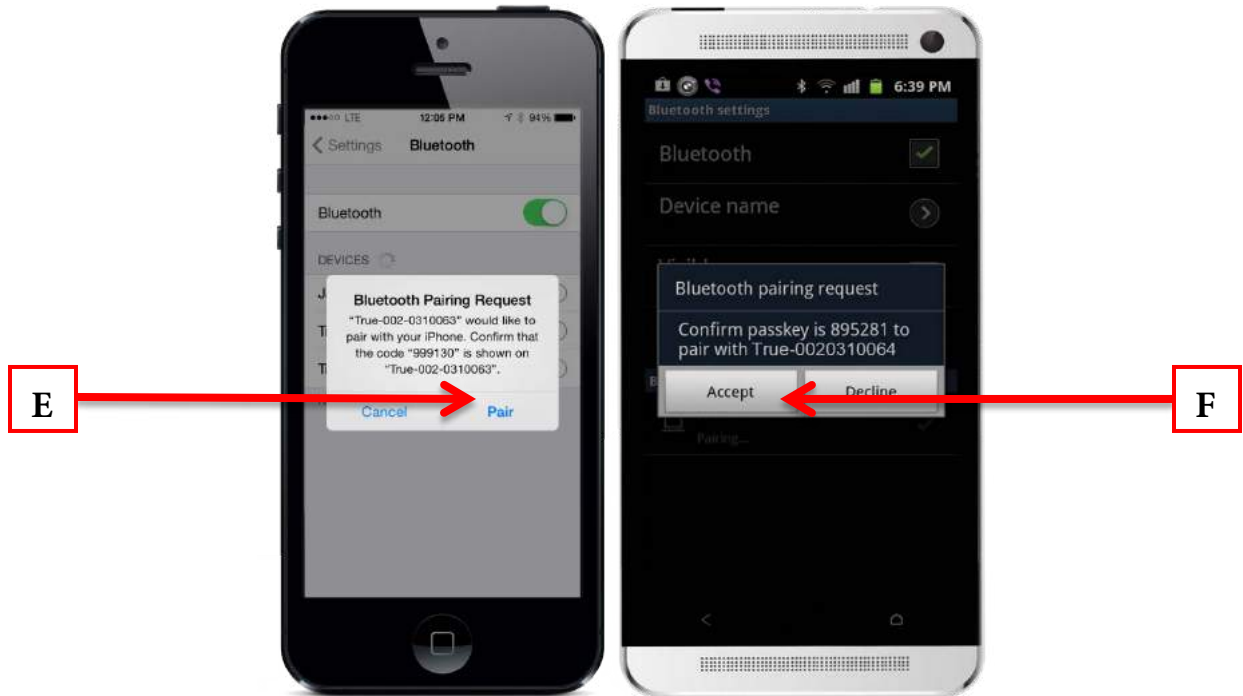

Once the Bluetooth pairing request has been accepted, the playback screen will be displayed. During playback, users can control volume (G), pause, advance or replay tracks by using the navigation buttons (H), and toggle between available audio sources by touching the Change Audio Button (I). To disconnect the Bluetooth audio device, simply touch the disconnect button (J).



CHAPTER 4A: TRANSCEND OPERATION

TV CONTROLS:

This console also features an integrated HDTV Tuner which allows the user to watch live programming in crisp, clear high Definition. The TV controls are built in to a Workout View Screen to allow the user to monitor their workout while enjoying their favorite shows.



A) Volume Controls:

Increases, Decreases or Mutes the audio volume from the TV program.

B) Change Audio:

Toggles between available audio sources.

C) Channel Controls

Used to display a full list of available channels or to change channels one at a time.

D) Closed Captioning

Toggles the closed captioning on or off.

*This button will only be visible when the program displayed supports closed captioning.

E) Screen Toggle:

Allows the user to switch back and forth between full screen and regular mode.

F) Stop:

Stops the current TV/TV audio feed.

CHAPTER 4A: TRANSCEND OPERATION

VIRTUAL ACTIVE®:

Virtual Active® provides users with a scenic, first-person video to enhance a workout. Audio from the web browser, TV, iPod®, and Bluetooth sources can be combined with this feature by pressing the Change Audio Button (A) to create a truly unique workout. Additionally, The Workout View Screen controls and displays are still available when using this feature in standard mode. The video can be stopped, without ending the workout, at any time by touching the Stop Button (B). To display the video in full screen mode, simply touch the Screen Toggle Button (C). Audio Volume (C) can also be adjusted.

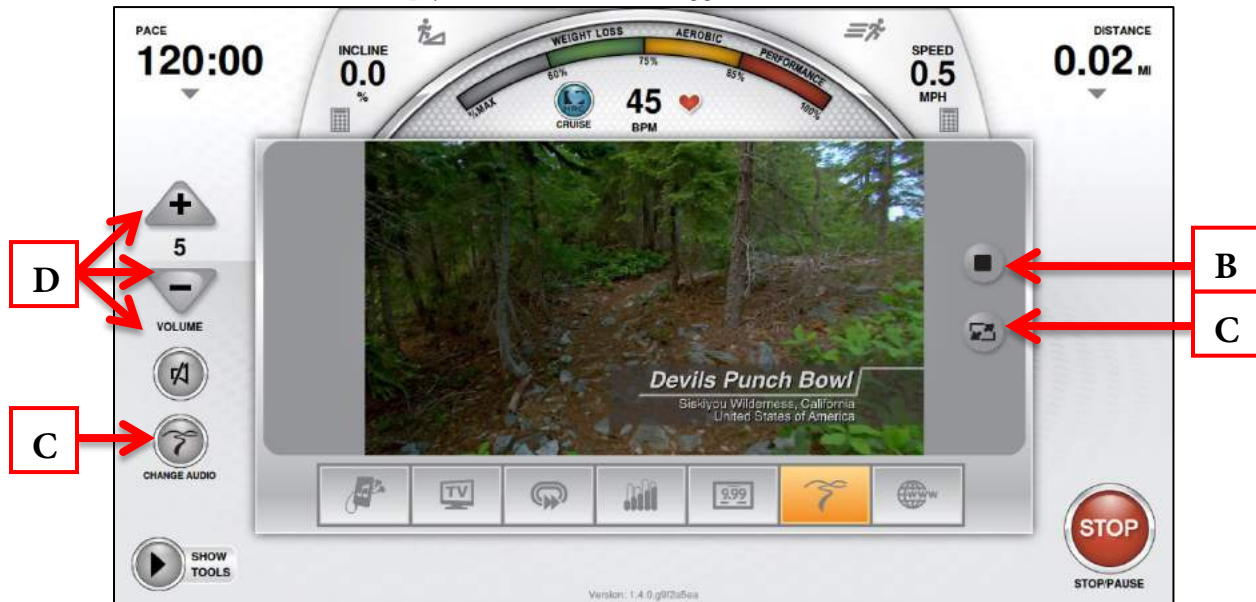

NETPULSE®:

Netpulse® is a digital fitness solution that enables personalized goal setting, activity-based social feeds, workout tracking, data management, and on demand content. Netpulse® works with 3rd party tracking apps and devices, along with a mobile app and web portal for capturing all of the user's data. Users that wish to utilize Netpulse® content should press the Sign in Button (A) on the home screen and enter their ID. If the user does not have a Netpulse® ID, they can create one by pressing the Create Account button (B) and following the onscreen instructions.

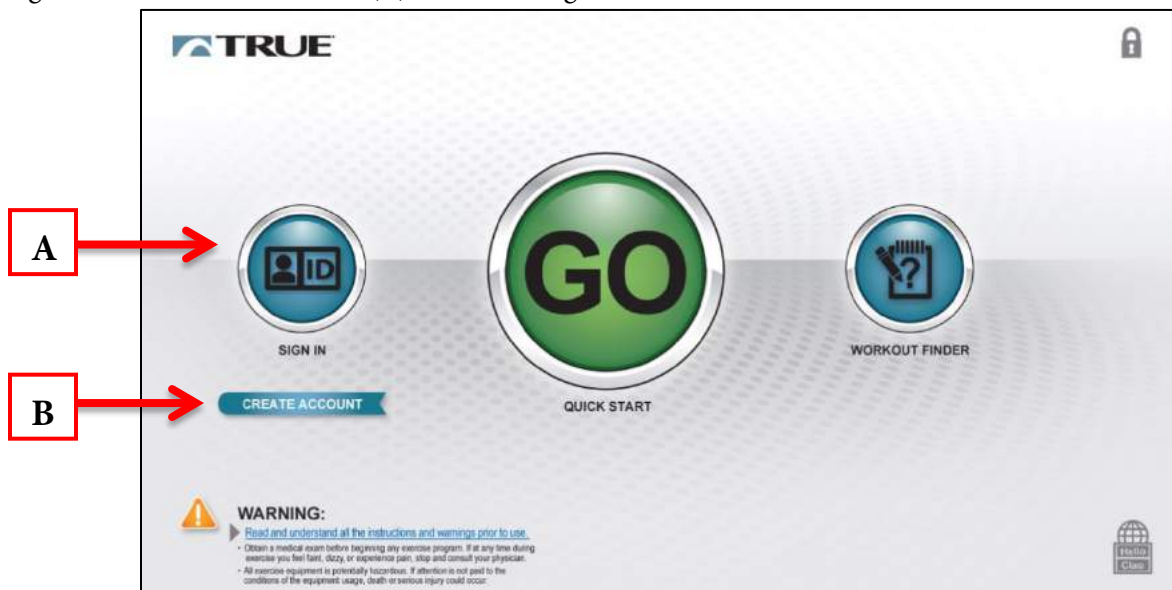

NOTE: This feature is only available in a Netpulse® enabled facility.

CHAPTER 4A: TRANSCEND OPERATION

ADVANCED CONSOLE FUNCTIONS:

Entering Service Mode:

Entering Service Mode can be completed by pressing and holding the TRUE logo (A) in the upper left corner of the home screen. When the word "TRUE" (B) begins to flash, release the logo and press and hold the lower right corner of the screen (C).



Main Menu:

After successfully entering service mode the screen below will be displayed. From this menu users can access all of the service mode features by navigating through the various menus.

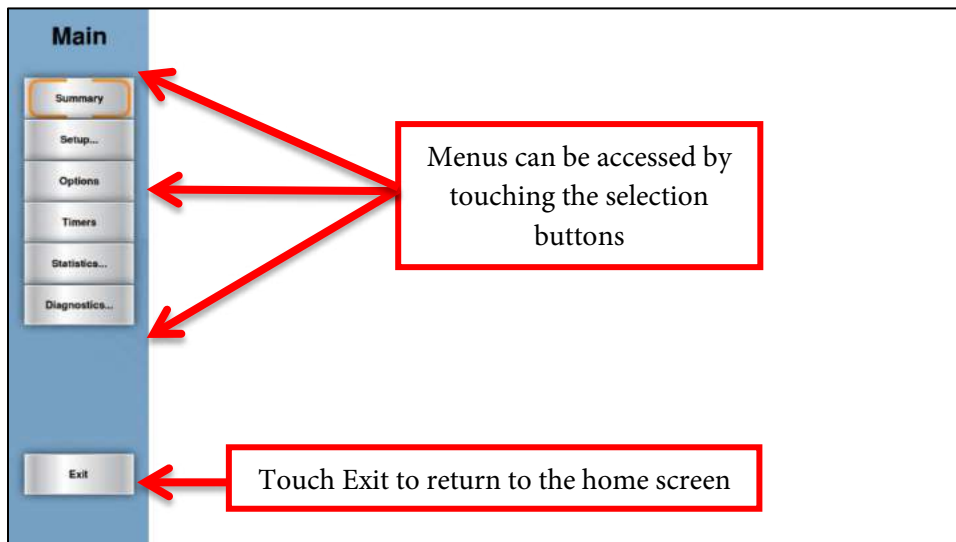

CHAPTER 4A: TRANSCEND OPERATION

ADVANCED CONSOLE FUNCTIONS (CONTINUED):

Summary Screen:

The Summary Screen will be the first screen displayed after entering service mode. This screen will give a general overview of the unit's setup.

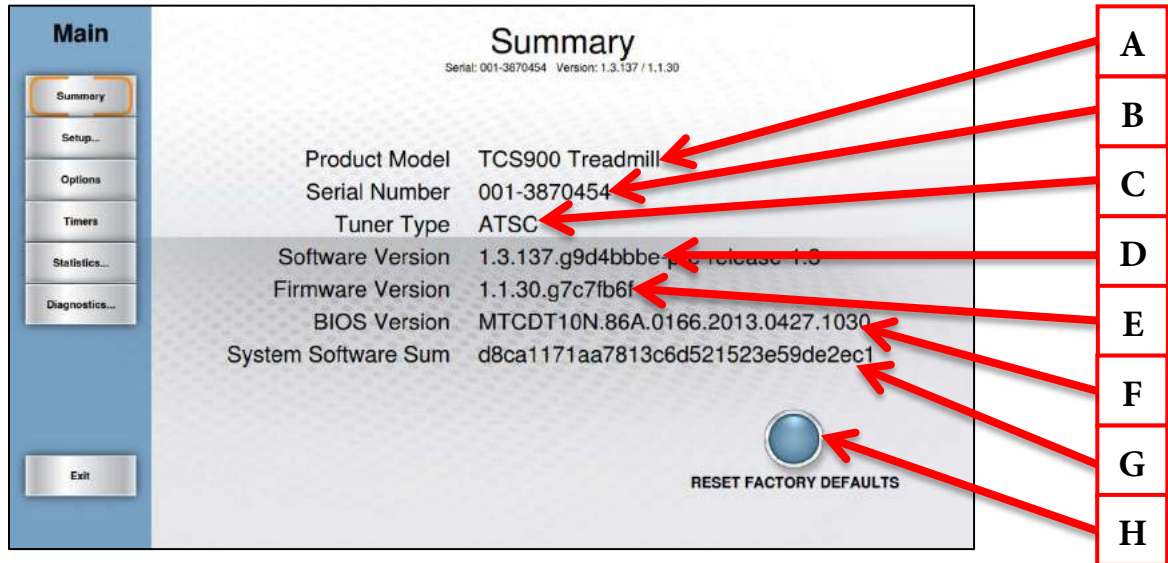

A) Product Model:

The model number that the console is currently configured to.

B) Serial Number:

The serial number of the console (not the base unit).

C) Tuner Type:

The type of TV tuner installed in the console.

D) Software Version:

The current version of software that is installed on the console.

E) Firmware Version:

The current version of firmware that is installed on the console.

F) BIOS Version:

The current BIOS version that is installed on the console.

G) System Software Sum:

Displays OS data that is used in the production of the console.

H) Reset Factory Defaults:

Resets all console settings to their factory defaults.

CHAPTER 4A: TRANSCEND OPERATION

ADVANCED CONSOLE FUNCTIONS (CONTINUED):

Setup Menu:

The setup menu is accessed by touching the Setup button on the main menu. The Setup Menu is separated into sub-categories and allows to users configure the console and to set up various functions of the unit.

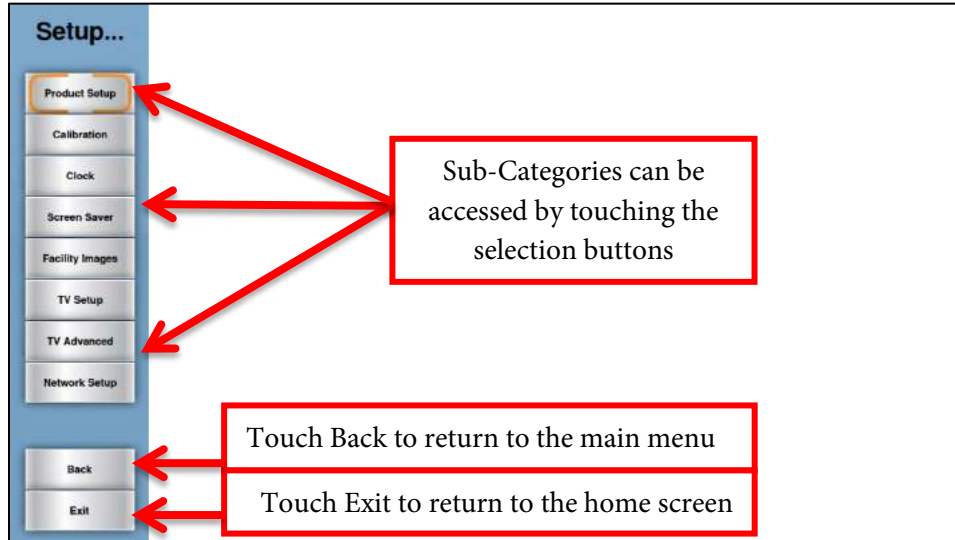

Setup Menu - Product Setup:

The Product Setup screen allows users to change the console configuration to match the unit on which it is installed. To change the console configuration:

- From the Main Menu, touch the Setup button.
- From the Setup Menu, Press Product Setup (A).
- Touch the correct model number to select it (B).
- Touch the Save key to save the configuration (C).

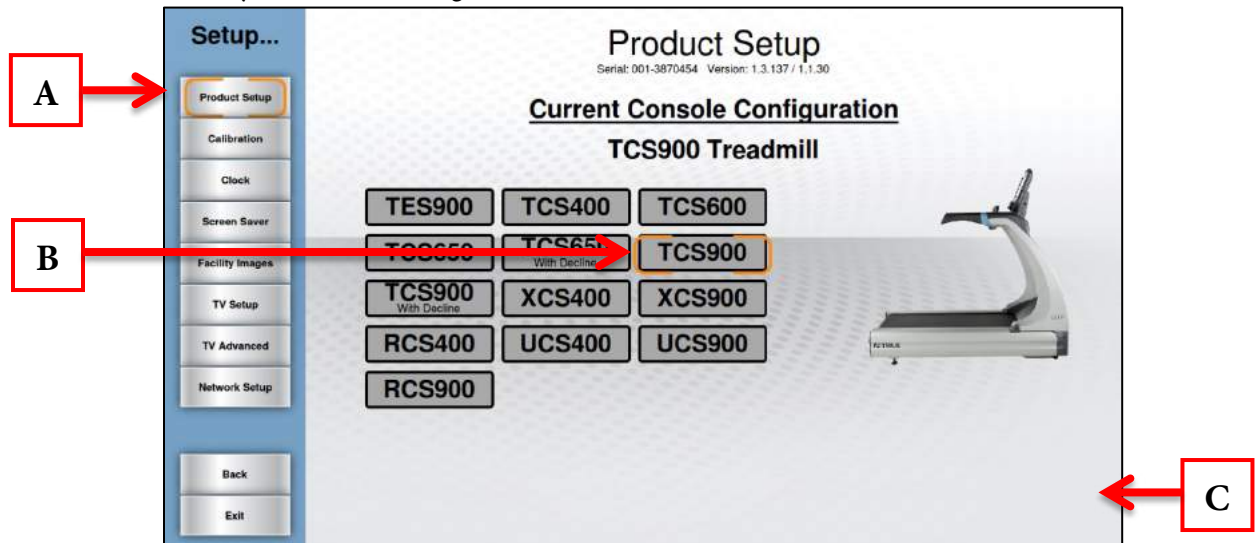

CHAPTER 4A: TRANSCEND OPERATION

ADVANCED CONSOLE FUNCTIONS (CONTINUED):

Setup Menu - Calibration:

Calibration will conduct a basic test of the drive and incline systems to ensure that they are operating as intended. Calibration may also be used by technicians to troubleshoot system faults.

⚠️WARNING:

This process will take full control of the treadmill and can be dangerous if caution is not taken.

- Calibration can take up to two minutes to complete.
- Do not stand on the treadmill during the calibration procedure.
- Verify that the machine is free of all parts and tools.
- Keep children and animals at a safe distance.

Calibration Steps:

- From the Main Menu, press the Setup button.
- From the Setup Menu, press Calibration (A)
- Press the Calibrate key (B)
- When complete, the console will display “Calibration Successful”.

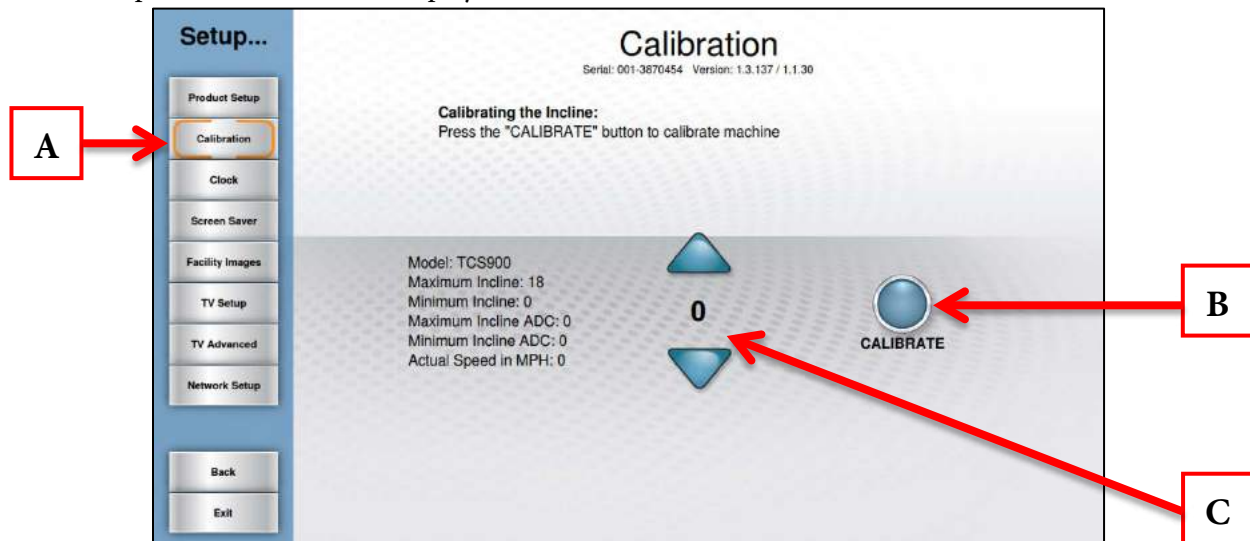

⚠️WARNING:

The Potentiometer Value (C) should only be adjusted by a trained service professional. Any adjustment made to the Potentiometer Value may result in unexpected errors or damage to the incline system.

CHAPTER 4A: TRANSCEND OPERATION

ADVANCED CONSOLE FUNCTIONS (CONTINUED):

Setup Menu - Clock:

Correctly setting up the clock will ensure that all workout data that is exported by a user will be correctly labeled. Correct time is also important for troubleshooting purposes when viewing the system's error log.

Setting the Clock:

- From the Main Menu, press the Setup button.
- From the Setup Menu, press the Clock Button (A).
- Touch the arrows (B) to adjust the date and time and use the slider button (C) to select AM or PM.
- Once the correct time and date are entered, touch the Next key (D).
- Use the slider (E) or swipe through the list of time zones until the correct time zone is shown in bold (F).
- Touch the Save key (G).

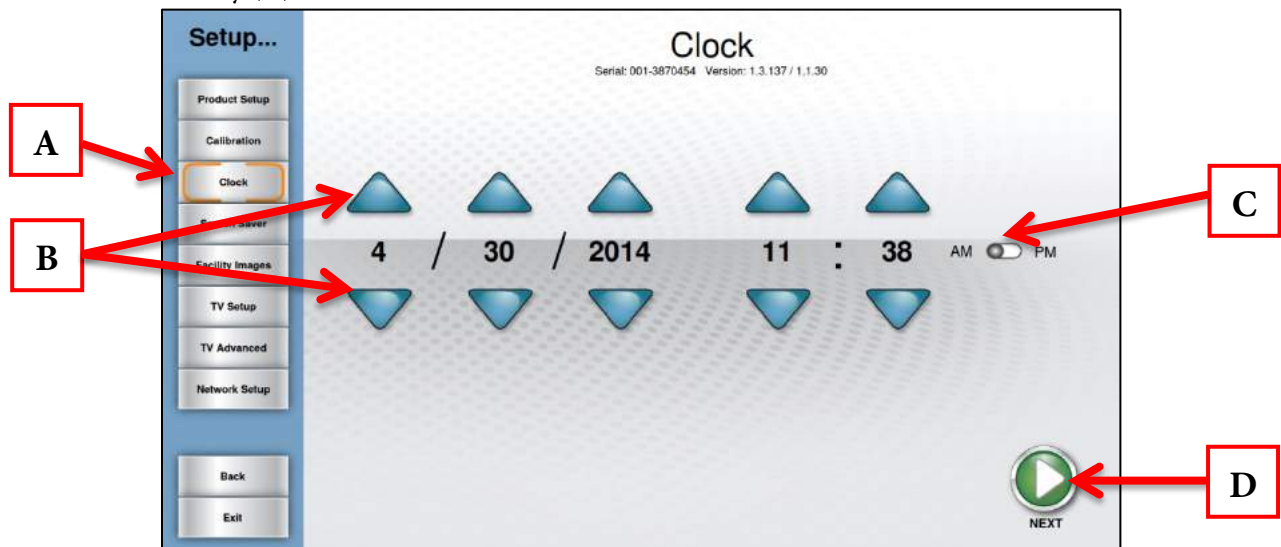

CHAPTER 4A: TRANSCEND OPERATION

ADVANCED CONSOLE FUNCTIONS (CONTINUED):

Setup Menu - Screen Saver:

Users can load JPG images to be used by the console as a custom screen saver. In order to be uploaded to the console, images will need to be placed on a USB drive in a folder named “screen saver” (case sensitive).

Importing Screen Saver Images:

- Touch the Screen Saver button (A)
- Insert the USB drive that contains the images into the console’s USB port.
- Verify the images in the preview window (B)
- Touch the Save button (C) to save the images to the console.

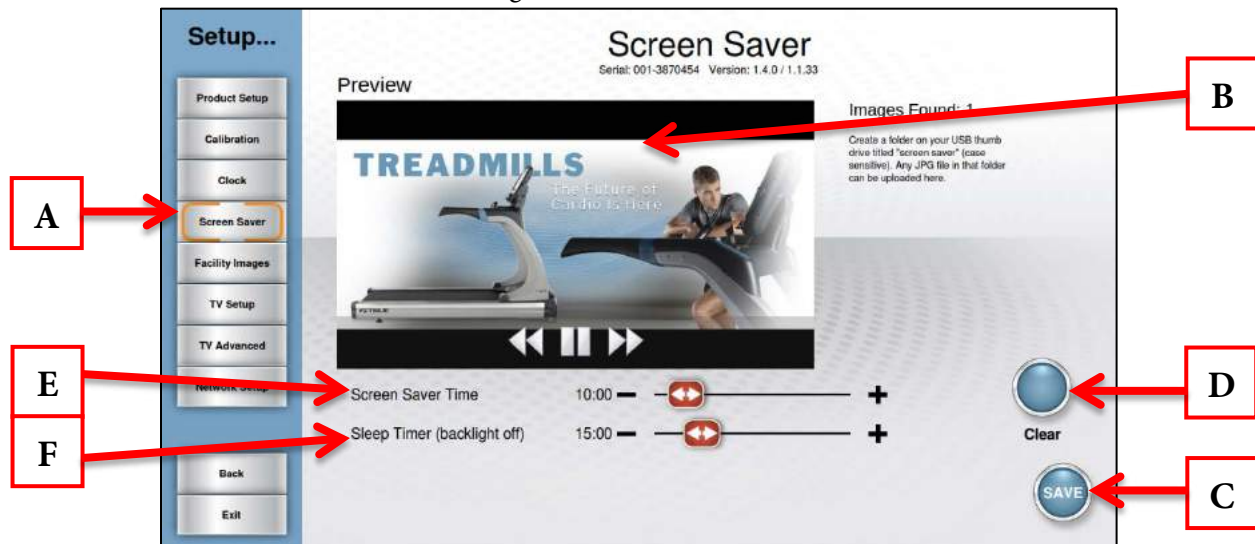

Additional Screen Saver Options:

- Custom Screen Saver images can be deleted by touching the clear button (D).
- The amount of time the console must be idle before the screen saver engages can be adjusted by using the Screen Saver Time Slider (E)
- The Sleep timer is a function that will turn off the console’s back light after a period of time to save energy. The amount of time the console must be idle before going to sleep can be adjusted by using the Sleep Timer Slider (F).

⚠️ WARNING:

Moving the Screen Saver Time completely to the left will disable the screen saver. Disabling the screen saver is not recommended and may cause damage to the screen and void the manufacturer warranty.

CHAPTER 4A: TRANSCEND OPERATION

ADVANCED CONSOLE FUNCTIONS (CONTINUED):

Setup Menu - Facility Images:

The Transcend console supports customizable facility images to help promote specials, events or endorse a brand. In order to be uploaded to the console, images will need to be placed on a USB drive in a folder named “facility” (case sensitive).

Importing Facility Images:

- Touch the Facility Images button (A)
- Insert the USB drive that contains the images into the console’s USB port.
- Verify the images in the preview window (B)
- Touch the Save button (C) to save the images to the console.



* Facility images can be deleted by touching the clear button (D).

Once loaded correctly, the facility Images will be displayed in the Facility Workout Data Screen (as shown below).

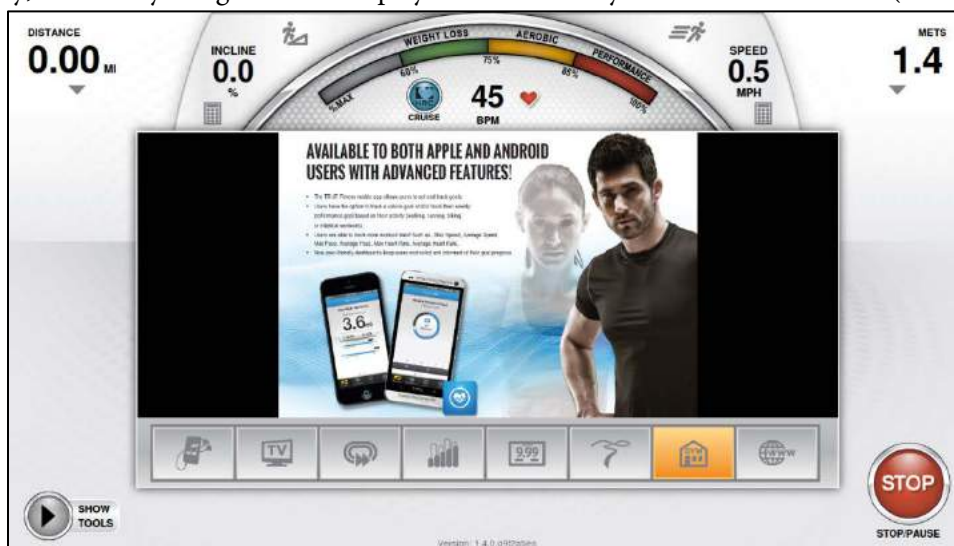

CHAPTER 4A: TRANSCEND OPERATION

ADVANCED CONSOLE FUNCTIONS (CONTINUED):

Setup Menu - TV Setup:

Transcend consoles have an integrated HDTV Tuner which allows the user to watch live programming in crisp, clear high Definition. Before any programming can be viewed, the TV signal needs to be set up. (TV Options will not be displayed on the Home Screen or in the Workout Data Screens until the TV Setup Steps have been completed)

TV Setup Steps:

- From the Setup Menu, touch TV Setup (A).
- Touch the type of signal that is being used to select it (B); Analog, Digital, or Both. (Digital is selected by default)
*When analog is selected the user will need to choose the analog standard (NTSC-M for the United States).
- Touch the Source Slider (C) to select between Antenna and Cable.
- Verify that the correct Country is listed (D).
- Touch Enable Aux Input (E) to enable or disable the AUX inputs located on the back of the console.
- Touch Begin Channel Scan (F) to begin scanning for channels.

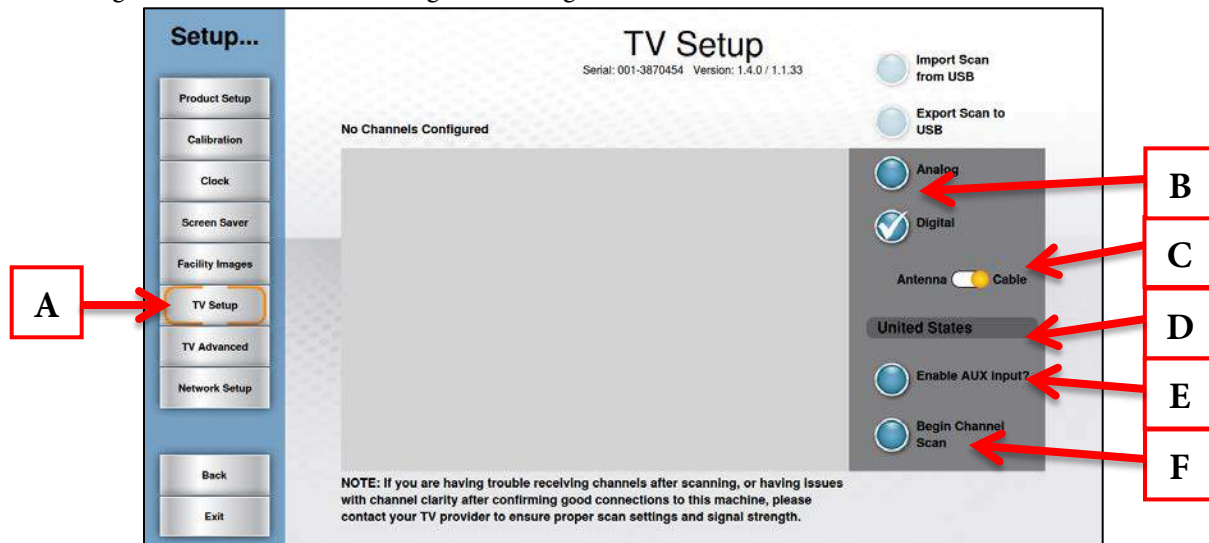

- Once the channel scan is complete, the channel list (G) will be populated with the available channels.

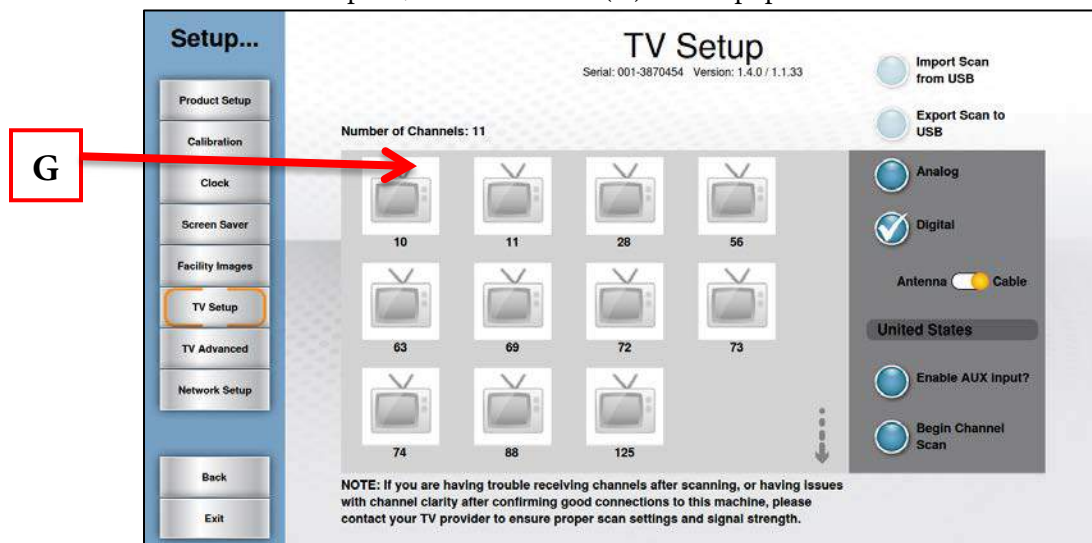

CHAPTER 4A: TRANSCEND OPERATION

ADVANCED CONSOLE FUNCTIONS (CONTINUED):

Setup Menu - TV Setup (continued):

Users can save time when setting up multiple units or maintain a back-up of their TV Setup Data by exporting it to a USB drive.

Exporting TV Setup Data to USB:

- Complete the TV Setup process.
- Insert a blank USB drive into the console's USB port.
- When all desired channels are listed in the Channel List (A), touch the Export Scan to USB Button (B)

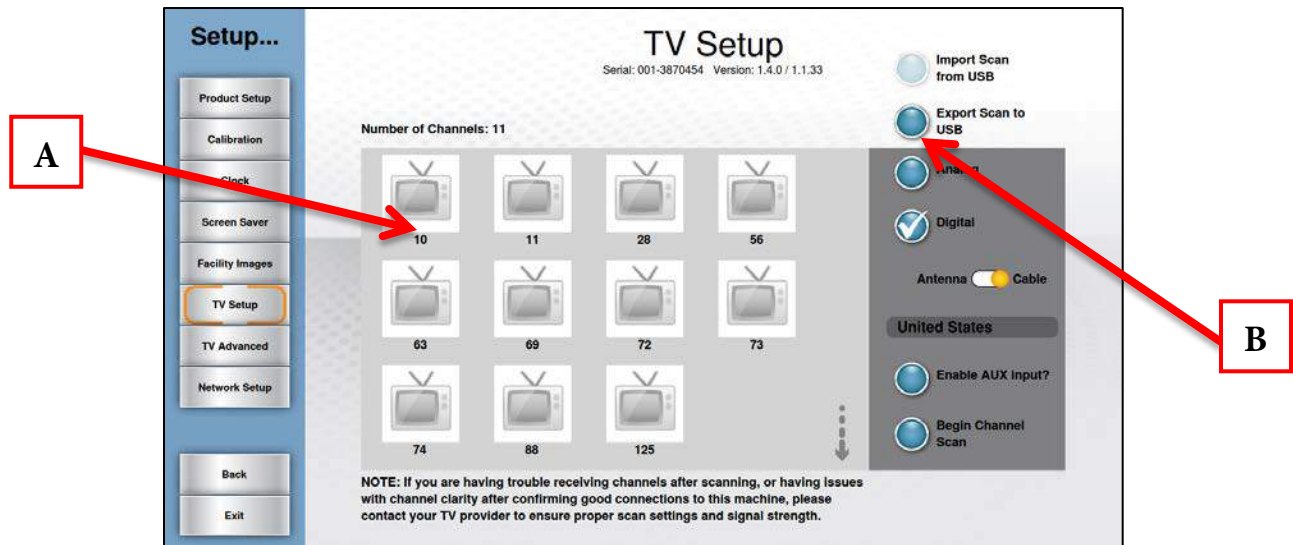

Importing TV Setup Data from USB:

- Navigate to the TV Setup screen.
- Insert the prepared USB stick into the console's USB Port.
- Touch Import Scan from USB (A).
- Once the import process is complete, verify that all channels are listed in the channel list (B).

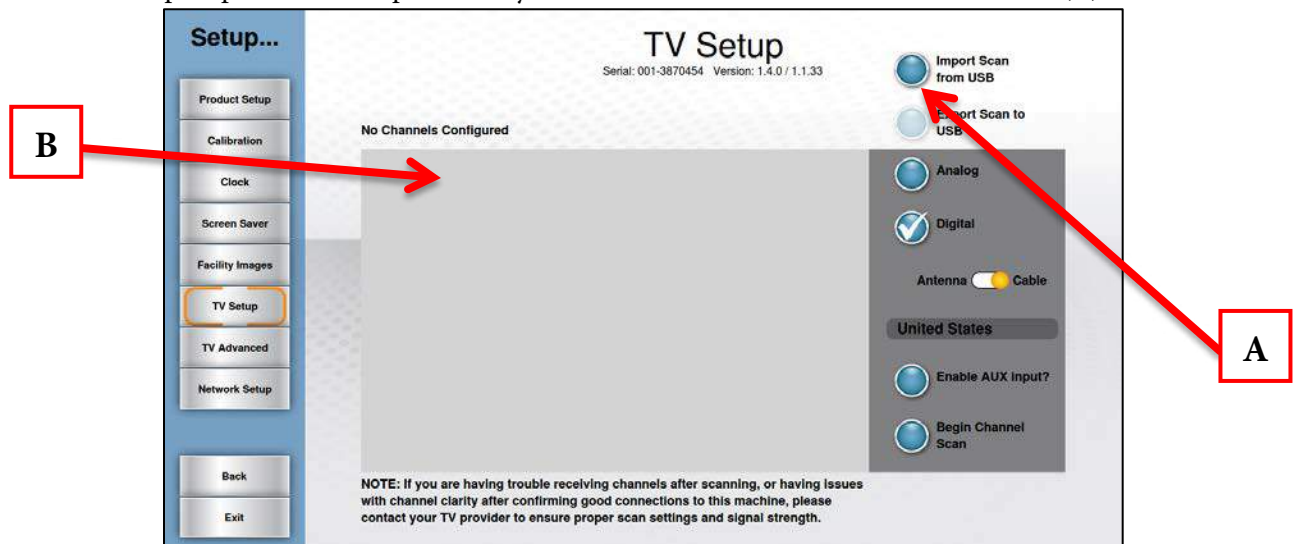

CHAPTER 4A: TRANSCEND OPERATION

ADVANCED CONSOLE FUNCTIONS (CONTINUED):

Setup Menu - TV Advanced:

The TV Advanced Menu allows users to fine tune their TV settings by adding channels, removing channels, and adding channel logos.

Add a Channel:

- Navigate to the TV Advanced Screen (A).
- Press the Add Channel Button (B) to access the Add Channel Screen.
- Use the Up/Down Arrows(C) to adjust the values (Standard, Frequency, Network, and Channel Number).
*Channel frequencies must be obtained from your television service provider.
- Once all values are correct, press OK (D) to save the channel.

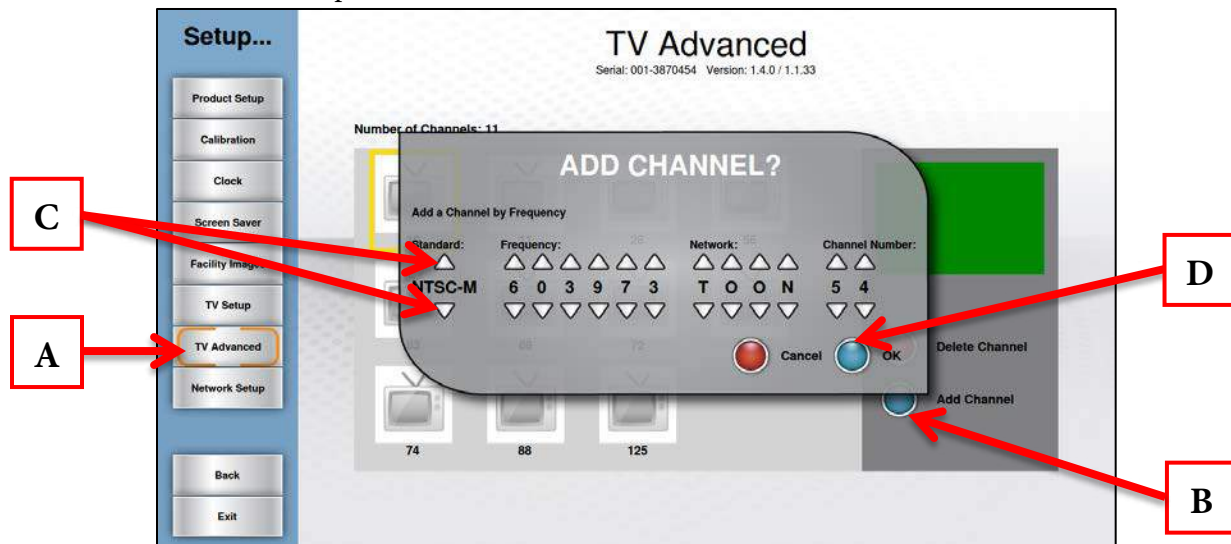

Deleting Channels:

- Touch the channel to be deleted to select it.
- Press the Delete Channel Button (A)
- Press Delete Channel (B) to delete the selected channel or Delete all Channels (C) to delete all channels.

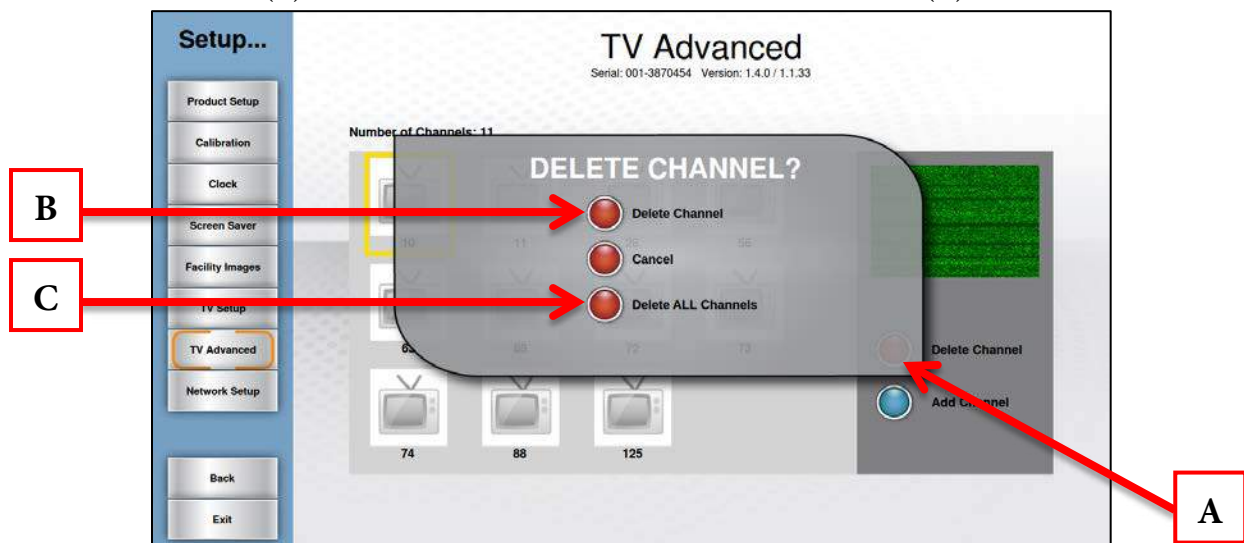

CHAPTER 4A: TRANSCEND OPERATION

ADVANCED CONSOLE FUNCTIONS (CONTINUED):

Setup Menu - TV Advanced (continued):

Using Channel logos allows users to quickly identify and select their favorite TV channels with minimal interruption to their workout.

Adding Channel Logos:

- Navigate to the TV Advanced Screen (A).
- Touch the desired channel in the Channel List (B) to select it
- Touch the channel again to enter the logo screen.

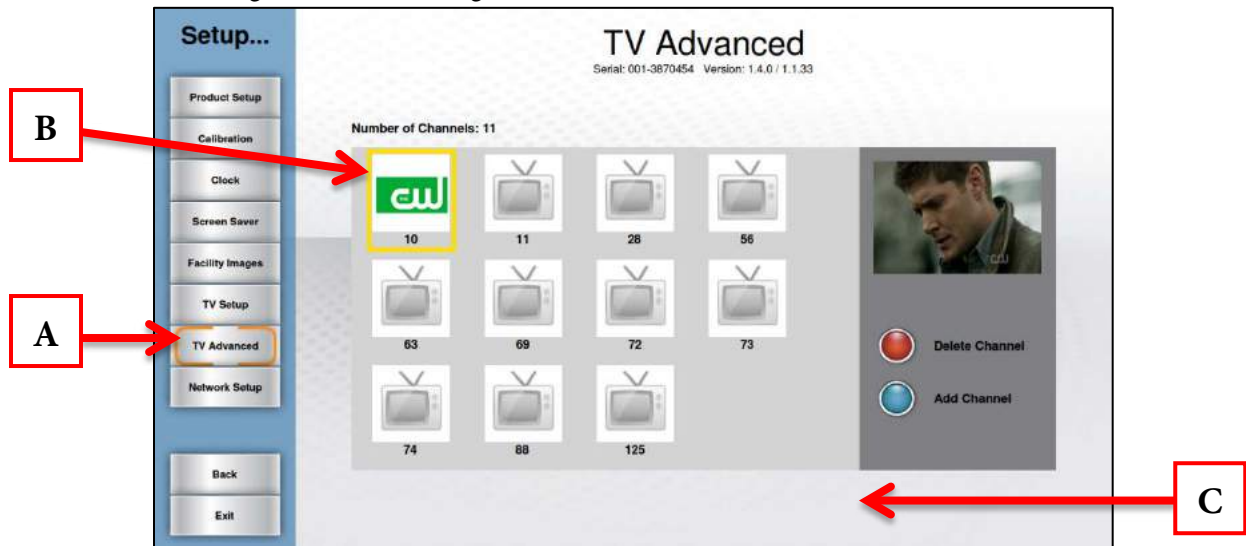

- Touch the logo (C) that corresponds to the selected channel.
- Repeat these steps for each channel for which a logo is available.



CHAPTER 4A: TRANSCEND OPERATION

ADVANCED CONSOLE FUNCTIONS (CONTINUED):

Setup Menu - Network Setup:

The Network Setup screen displays the current network information for the console. This screen also allows users to setup wired or wireless internet connection, enable web browsing, and allows for Netpulse® configuration (in a Netpulse® enabled environment). To connect to a network, simply touch the Setup Connection button (A) and select the desired network from the list (and enter the password if necessary) and then press connect.

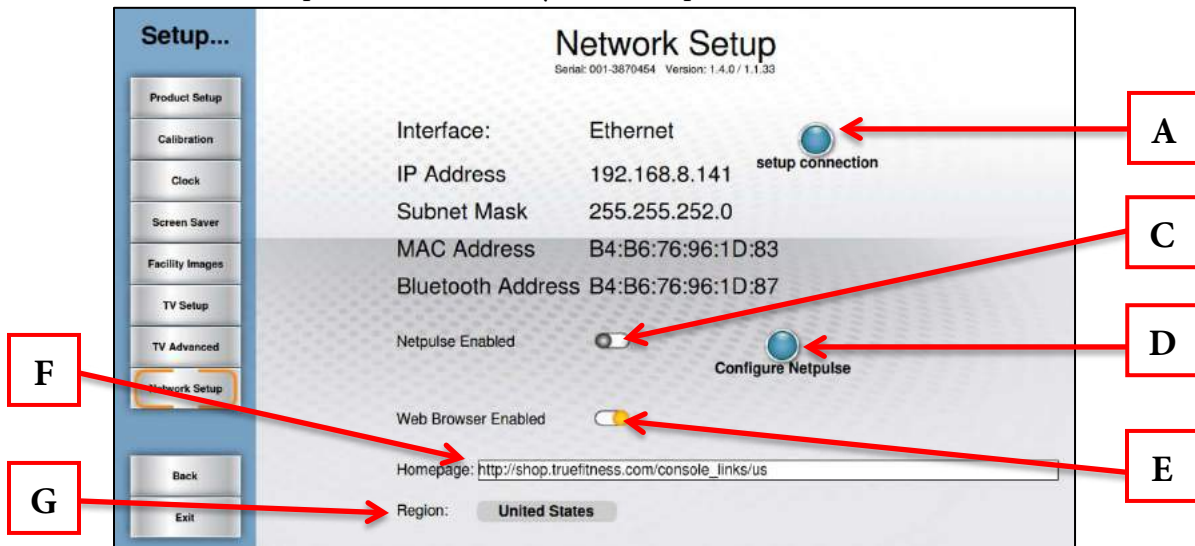

Configuring Netpulse®:

- Touch the Netpulse Enabled Slider button (C) to enable it.
- Touch the Configure Netpulse Button (D)
- On the screen that follows, touch the Test Network button.
- Once the screen displays the message “All network tests passed”, touch the Install button.
- The screen will then display the message “Installation was successful”.
- Touch the Back button to return to the Network Setup screen.

Enabling the Web Browser:

- Touch the Web browser Enabled Slider (E) to enable it.
- Accept the Internet Service Agreement.
- Select a homepage by touching the Homepage Address Bar (F) and typing the web address of the desired page and pressing Enter to confirm the page.
- Ensure that the correct Region (G) is displayed.

CHAPTER 4A: TRANSCEND OPERATION

ADVANCED CONSOLE FUNCTIONS (CONTINUED):

Options Menu:

The Options menu allows users to customize settings on the console to meet their needs. The settings in this menu save automatically.

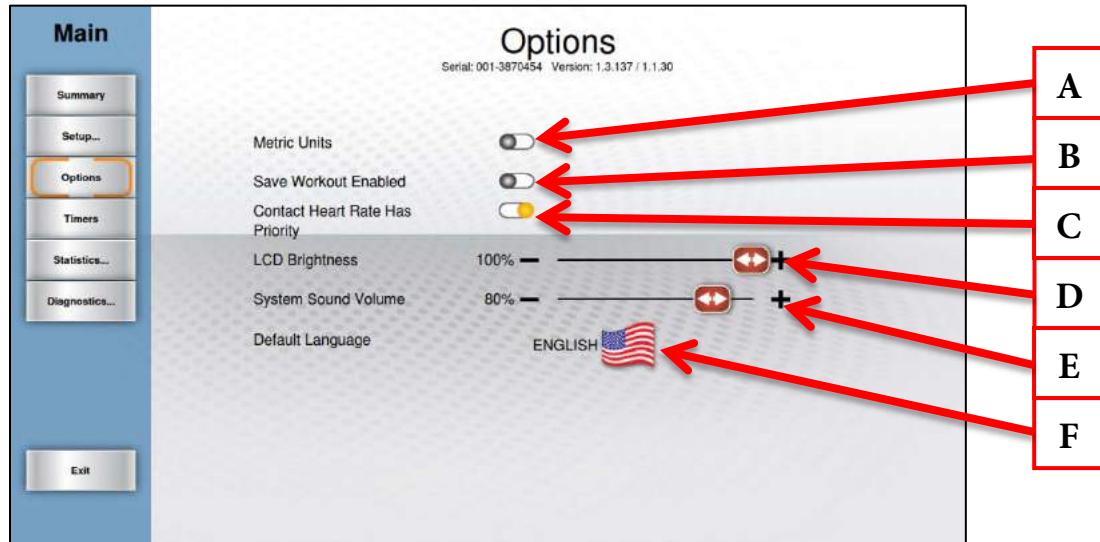

A) Metric Units:

When enabled, the console will display all Metric units rather than American Standard.

B) Save Workout Enabled:

Turn on this feature to allow users to save custom workouts to the console.

C) Contact Heart Rate Has Priority:

When enabled, the console will attempt to read heart rate data from the contact heart rate grips before reading data from a wireless chest strap.

*When this option is turned off, telemetry heart rate will take priority.

D) LCD Brightness:

Use the slider to adjust the brightness of the touchscreen display.

E) System Sound Volume:

Use the slider to adjust the volume of the notifications and beeps that come from the console.

F) Default Language:

Touch the flag to select a different language. Once a new default language has been selected, all menus, options and workout data will appear in that language.

CHAPTER 4A: TRANSCEND OPERATION

ADVANCED CONSOLE FUNCTIONS (CONTINUED):

Timers Menu:

The Timers Menu allows for time limits to be set on various console features and functions.

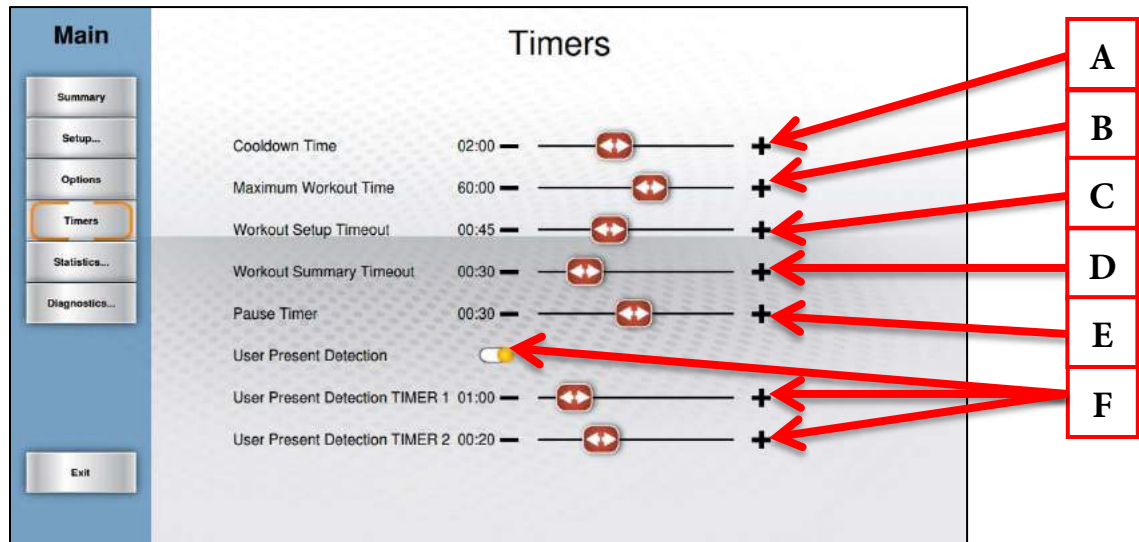

A) Cooldown Time:

Use the slider to adjust the length of the cooldown segment at the end of a workout.

B) Maximum Workout Time:

This setting will limit the amount of time that all workouts can last (this setting does not apply to quickstart workouts, manual workouts or distance workouts).

C) Workout Setup Timeout:

Choose how long the workout data entry screen will remain on the display without any user interaction. By choosing the “off” setting, the data entry screen will be displayed until closed by a user.

D) Workout Summary Timeout:

Determines the amount of time the Workout Summary Screen will remain on the display. By choosing the “Off” setting, the summary will be displayed until ended by a user.

E) Pause Timer:

This setting will limit the amount of time that a workout can be paused before it automatically ends. By choosing the “Off” option, the unit will remain paused until the user resumes or ends the workout.

F) User Present Detection (AC drive systems only):

When User Present Detection is enabled the treadmill will pause if it does not detect a normal amp draw which would be indicative of the weight of the user on the treadmill. Timer 1 will set the amount of time before the console displays a User Present Notification and Timer 2 will set the amount of time that the notification is displayed on the console before the treadmill is stopped.

CHAPTER 4A: TRANSCEND OPERATION

ADVANCED CONSOLE FUNCTIONS (CONTINUED):

Statistics Menu:

The statistics menu provides an overview of how and how long the unit has been used. Touching the summary button (A) will provide a usage summary. Run Hours (B) is the total number of hours the unit has been used. Machine Distance (C) is the total distance in miles that the belt has traveled. Distance (D) is the amount of distance the belt has traveled since the last time the Clear Mileage button (E) was pressed.

*The Distance/Clear Mileage feature is helpful for tracking mileage in a preventive maintenance schedule.

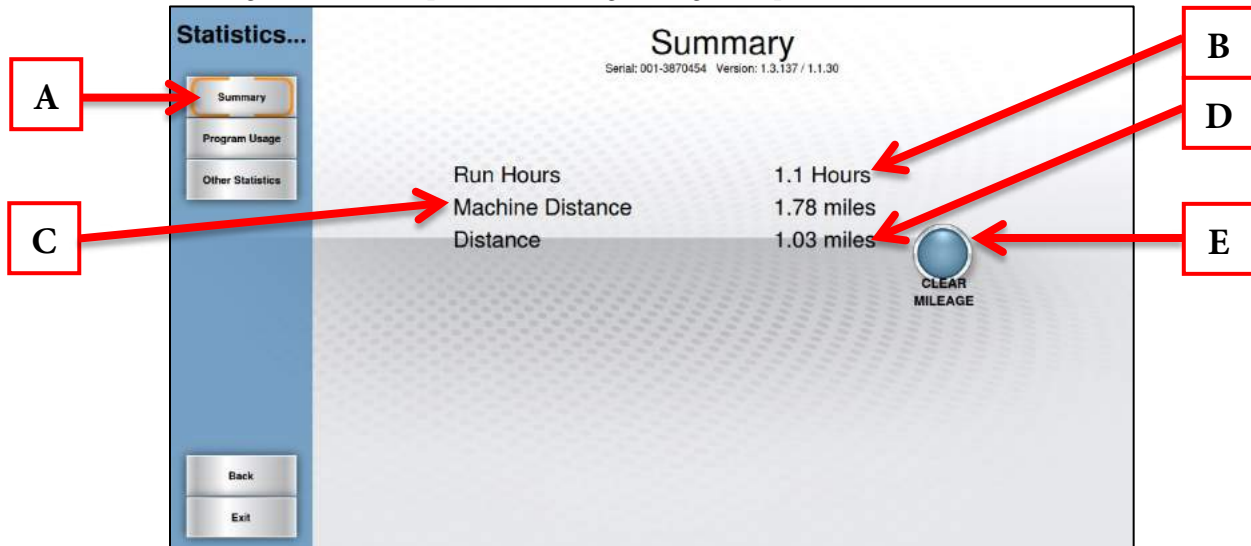

Touching the Program Usage button (F) will provide a list of programs that have been used on the unit and how many times those programs have been used. These statistics can be reset by touching the Clear button (G), but it is not recommended.

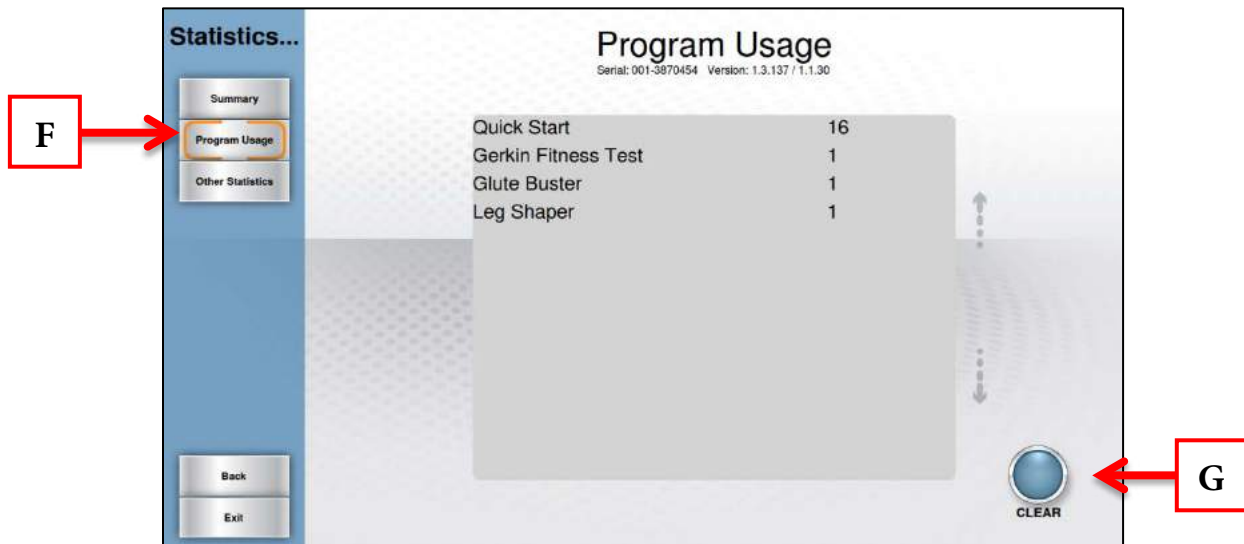

CHAPTER 4A: TRANSCEND OPERATION

ADVANCED CONSOLE FUNCTIONS (CONTINUED):

Diagnostics Menu:

The Diagnostics Menu contains tools used to help diagnose errors and performance issues. The first screen Displayed is Tests:

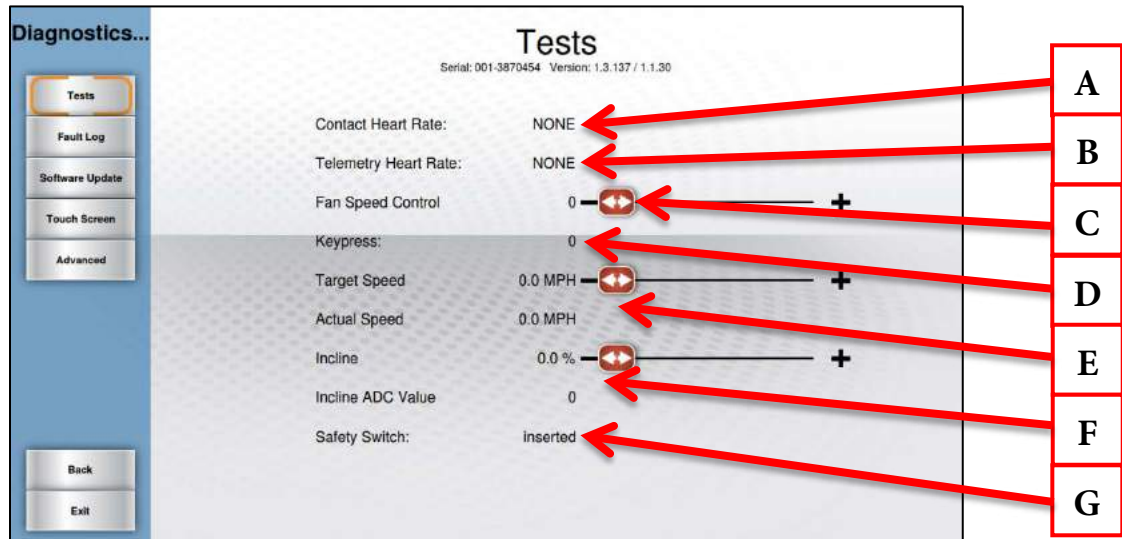

A) Contact Heart Rate:

Ensures the unit is receiving the data by displaying the user's heart rate when the contact heart rate pads are gripped.

B) Telemetry Heart Rate:

Use a wireless heart rate strap or simulator to test if the unit is receiving wireless heart rate data. If there is a reading displayed without the use of a heart rate strap or simulator, there is outside interference from another source.

*This unit is designed to receive 5 khz non-coded transmissions only.

C) Keypress:

When a quick access key is pressed on the unit, "NONE" will change to indicate which key is being pressed. In the event of a stuck key, the key that is being engaged will display.

D) Fan Speed Control:

Using the slider allows users to test the fan independent of a program.

E) Target Speed/Actual Speed:

Use the Target Speed slider to command the treadmill to move and verify that the belt is moving at the commanded speed using the actual speed readout.

F) Incline/Incline ADC Value:

Used to troubleshoot incline system faults by commanding the unit to incline with the incline slider and reading the Incline ADC Value.

G) Safety Switch:

Used to verify that the console is able to read the safety key.

CHAPTER 4A: TRANSCEND OPERATION

ADVANCED CONSOLE FUNCTIONS (CONTINUED):

Diagnostics Menu - Fault Log:

Touching the Fault Log button (A) in the Diagnostics Menu, will display a time stamped list of recent fault codes that can be helpful in the troubleshooting process. The Error Log can be reset by touching the Clear button (B), but it is not recommended.

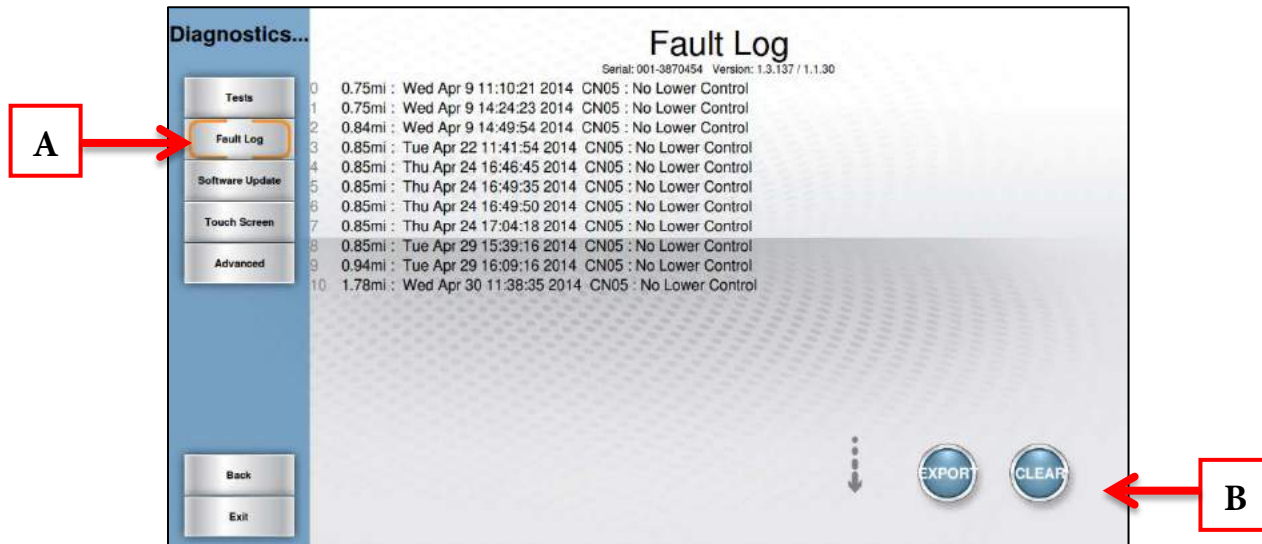

Diagnostics Menu - Software Update:

TRUE may periodically release software updates to ensure users enjoy the best workout experience available. To update the console software, download the update program (A) from truefitness.com and load the software to a blank USB drive by following the downloadable instructions.

***DO NOT place the installation program on the USB stick! The program must be run on a Windows based computer!**

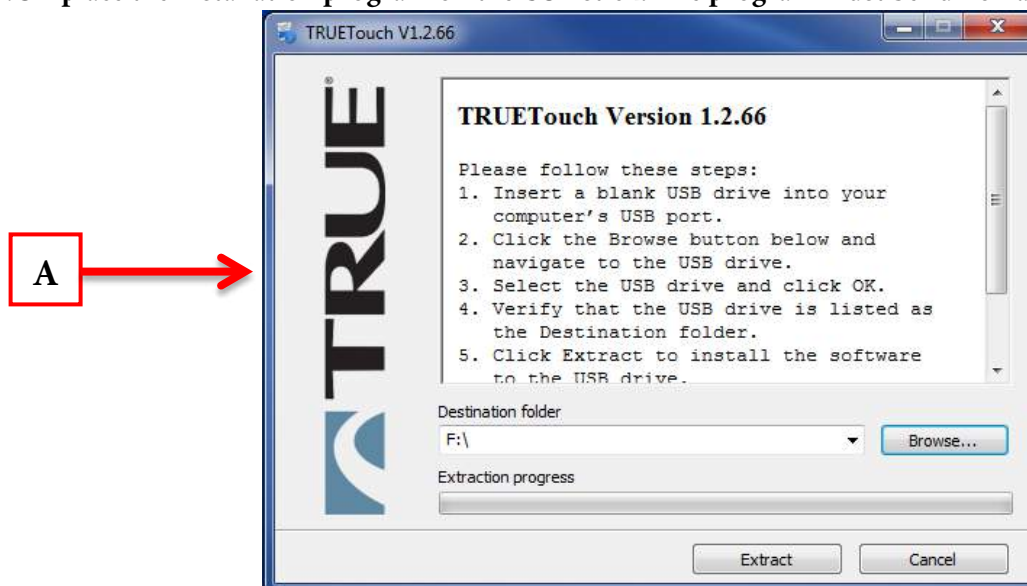

⚠️ WARNING:

Disconnecting the power source, switching the unit off or pressing buttons on the console will disrupt the information flow and potentially cause fatal errors.

CHAPTER 4A: TRANSCEND OPERATION

ADVANCED CONSOLE FUNCTIONS (CONTINUED):

Diagnostics Menu - Software Update (continued):

- Insert the USB drive containing the software update into the console's USB port.
- From the Main Menu, press the Diagnostics button. Then press Software update button (A).
- When the console locates the software update, press the Update Software button (B)
- After the installation of the software update, press the Load Firmware button (C).

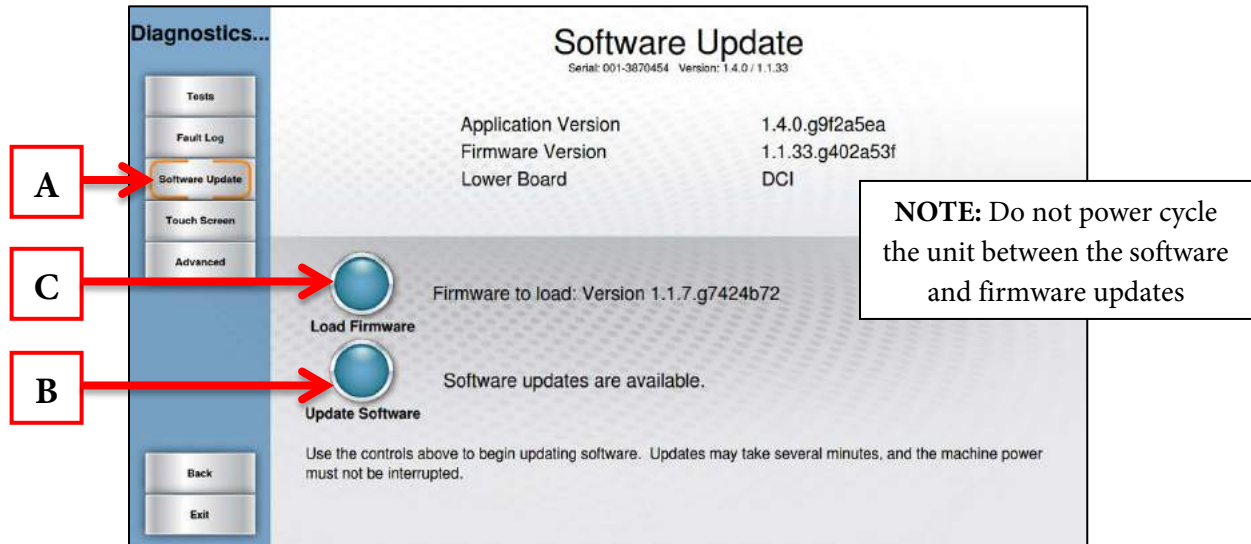

Diagnostics Menu - Touch Screen:

Touching the Touchscreen key (A) will open the touchscreen calibration tool. On the first screen displayed, users can touch anywhere in the white area (B) and a small red box (C) will appear to verify screen function. Touching the Calibrate button (D) will begin a touchscreen calibration. During this process, targets will appear on the screen and the user must press and hold each target until it turns red to complete the calibration.

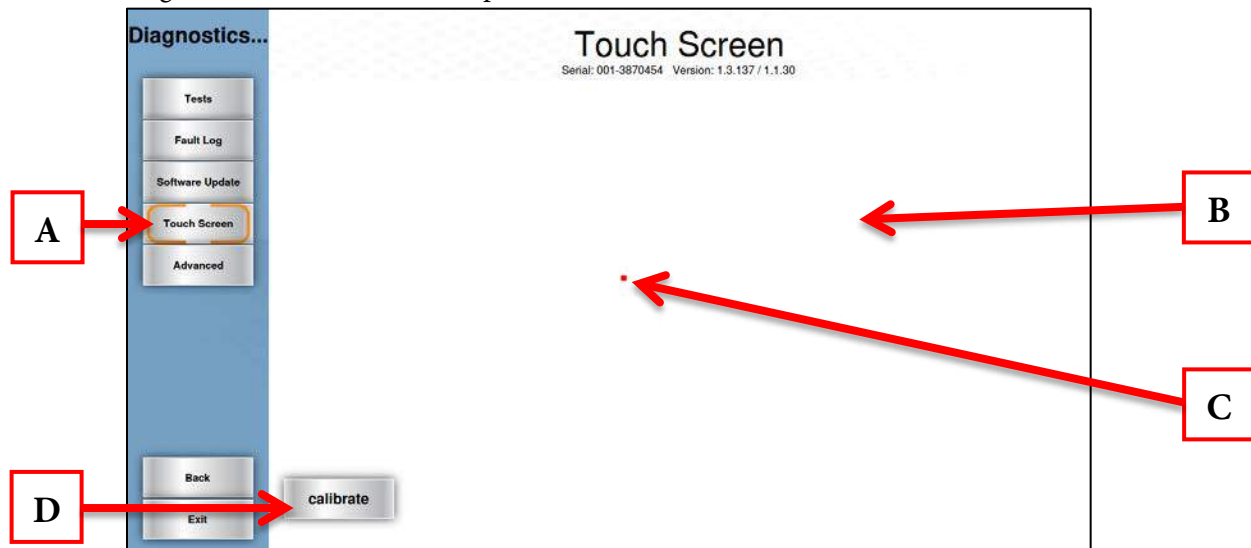

Diagnostics Menu - Advanced:

The advanced screen contains multiple tools that are used in the production of the console and for demonstration purposes. It is recommended to leave these settings in their default positions.

CHAPTER 4B: ESCALATE¹⁵ OPERATION

ESCALATE¹⁵ OVERVIEW:



CHAPTER 4B: ESCALATE¹⁵ OPERATION

ESCALATE¹⁵ OVERVIEW (CONTINUED):

TFT Display:

Used to monitor or control a workout and feature navigation.

Selection Buttons:

Used to navigate menus and make selections via the LCD Display.

Navigation Buttons:

Used to navigate menus and control features of the console.

Start:

Allows the user to begin a Quick Start workout or preset workout.

TV Button:

Displays the TV interface.

USB Jack:

Allows users to export workout data to an external USB drive or update the console software.

Headphone Jack:

Standard 3.5mm audio jack used to connect headphones to the console during media playback.

Back Button

Used in navigate back within various console features.

30 Pin iPod® Connector:

Standard 30 pin iPod® connector used to connect an iPod® to the console.

Reading Rack:

This ledge on the console can be used to hold a book, magazine, e-reader, or tablet computer during a workout.

Enter:

Used to confirm selections.

Stop:

Stops/Pauses a workout. Press and hold this key for five seconds to reset the unit.

Cooling Fan:

Integrated fan that delivers a cooling flow of air during a workout.

CHAPTER 4B: ESCALATE¹⁵ OPERATION

CONSOLE NAVIGATION:

Home Screen:

The Home Screen is displayed on the console when there is no workout in progress. From this screen the user is able to select from various options to begin a workout or view media. To select an item, use the Left/Right Selection Buttons (A) to highlight the item and then press the Enter button (B).

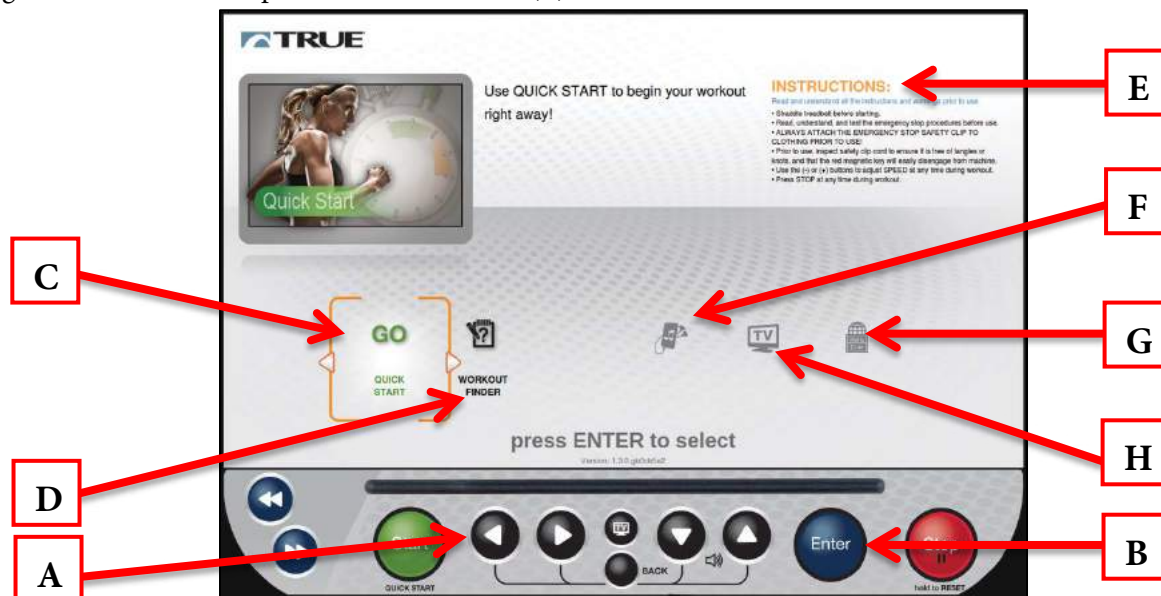

C) Quick Start

Starts a Quick Start workout in which the user controls all settings. The workout continues until it is ended by the user.

D) Workout Finder

Displays preset workouts categorized by goal focus categories.

E) Safety Instructions

Displays a list of safety instructions for users to review prior to beginning a workout.

F) iPod®/Audio Device

Displays the iPod®/Audio Device interface without starting a workout.

G) TV

Displays TV interface without starting a workout.

H) Language Options

Allows users to choose between 12 language options.

CHAPTER 4B: ESCALATE¹⁵ OPERATION

CONSOLE NAVIGATION (CONTINUED):

Selecting a Preset Workout:

Preset workouts are accessed by selecting the Workout Finder option on the home screen. Workouts are organized into 5 categories. To view the workouts in a category, select the category (A) by using the Left/Right Selection Buttons (B) and then press Enter (C). Workouts can also be viewed in an uncategorized list by selecting the Show All Workouts option(C).



Workout Data Entry Screens:

Workout data entry screens allow the user to input their personal information or workout goals prior to beginning a preset workout. To set a value (A), select it using the Left/Right Selection Buttons (B) and then use the Up/Down Selection Buttons (C) to adjust the value to the desired setting. After all values are set, press start to begin the workout.

*Workout Data Entry Screens vary by program selection.



CHAPTER 4B: ESCALATE¹⁵ OPERATION

CONSOLE NAVIGATION (CONTINUED):

Workout View Screens:

During any workout a Workout View Screen will be displayed to give the user a comprehensive visual overview of their current workout data. Users can switch between the available Workout View Screens by using the Left/Right Selection Buttons (F).

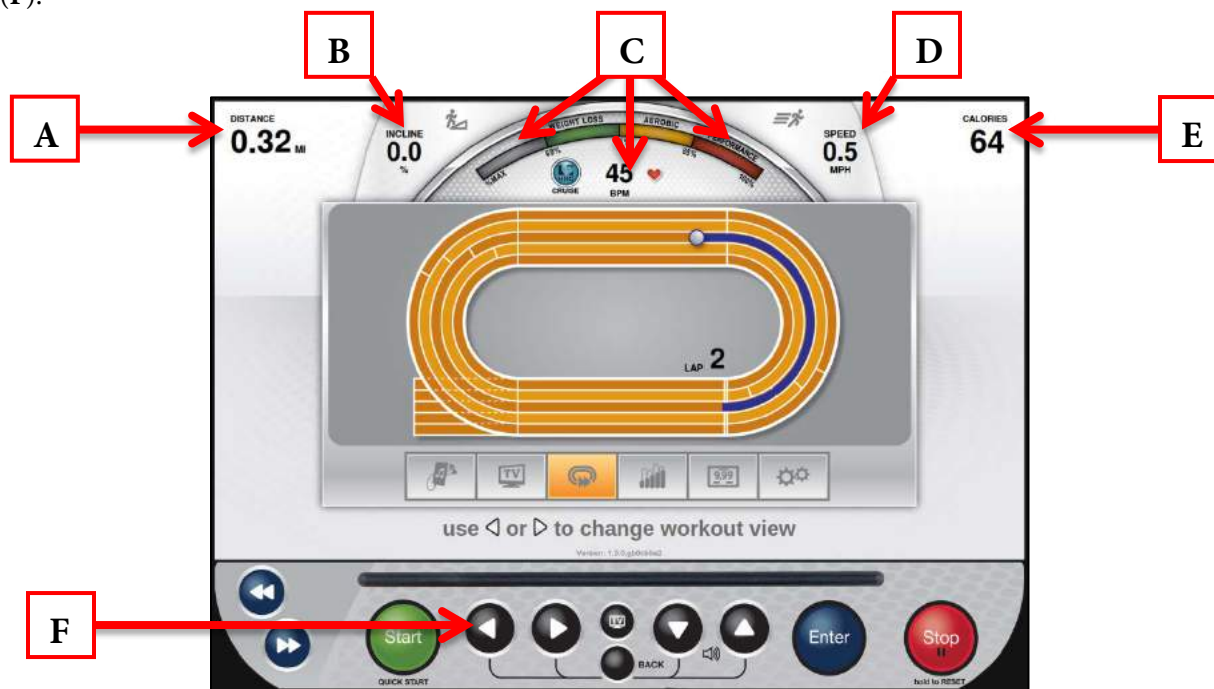

A) Data Display #1:

This display will toggle between multiple data points throughout the workout. These data points vary by program, but include Time, Distance, and Pace.

B) Incline:

Displays the current incline level.

C) Heart Rate Information:

When the user is wearing a heart rate chest strap or utilizing the contact heart rate system, their heart rate will be displayed in beats per minute (bpm) and in the graphic meter. The graphic meter is based on age and will gauge the user's approximate heart rate within 3 target levels; Weight Loss, Aerobic or Performance.

D) Speed:

Displays the current speed of the treadmill belt.

E) Data Display #2:

This display will toggle between multiple data points throughout the workout. These data points vary by program, but include Calories, Distance, and METS.

CHAPTER 4B: ESCALATE¹⁵ OPERATION

CONSOLE NAVIGATION (CONTINUED):

Tools Screen Controls:

The Tools Screen contains controls that allow users to adjust settings during their workout. The Tools screen can be reached by using the Left/Right Selection Buttons (A) during any workout. The Navigation Buttons (B) are used in the Tools Screen to select between the available options. Once the desired tool has been selected, press Enter (C) to confirm the selection.

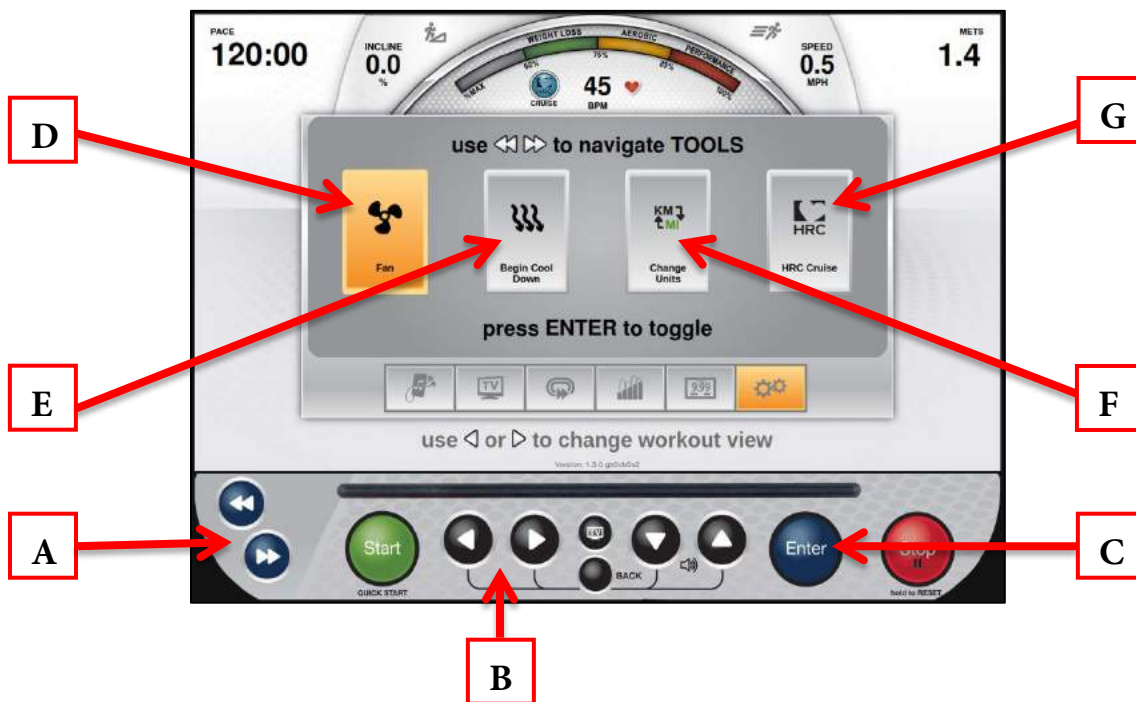

D) Fan:

This tool toggles the cooling fan on and off.

E) Cool Down:

Allows the user to end their current workout with a two minute low intensity cool down period. When Cool Down is activated the unit is in manual mode and the user directly controls all settings.

F) Change Units:

Allows users to change the data readouts between English Standard and Metric Units.

G) HRC Cruise Control:

Engages Heart Rate Control to allow the equipment to maintain the user's current heart rate through automatic speed and incline adjustments (when the user is utilizing heart rate monitoring).

CHAPTER 4B: ESCALATE¹⁵ OPERATION

CONSOLE NAVIGATION (CONTINUED):

Workout Summary Screen:

At the end of a workout the Summary Screen will display an overview of the workout data. The workout data can be exported to the TRUE Fitness App via Bluetooth or to a USB drive that is connected to the console's USB port. To export the Workout Data, use the Left/Right Selection Buttons (A) to select Save (B) and then press the Enter Button (C). If the user requires more time to view the summary or to export the workout data, they can select More Time (D) and press the Enter Button (C) to extend the time that the summary remains on the screen.



TV CONTROLS:

This console has an integrated HDTV Tuner which allows the user to watch live programming in crisp, clear high Definition. The TV controls are built in to a Workout View Screen to allow the user to monitor their workout while enjoying their favorite shows. While watching TV, users can control volume using the Up/Down Selection Buttons (A) and change channels using the Navigation Buttons (B) or by selecting a channel from the list of available channels by pressing the TV Button (C). To enter full screen mode, simply press the Enter Button (D).

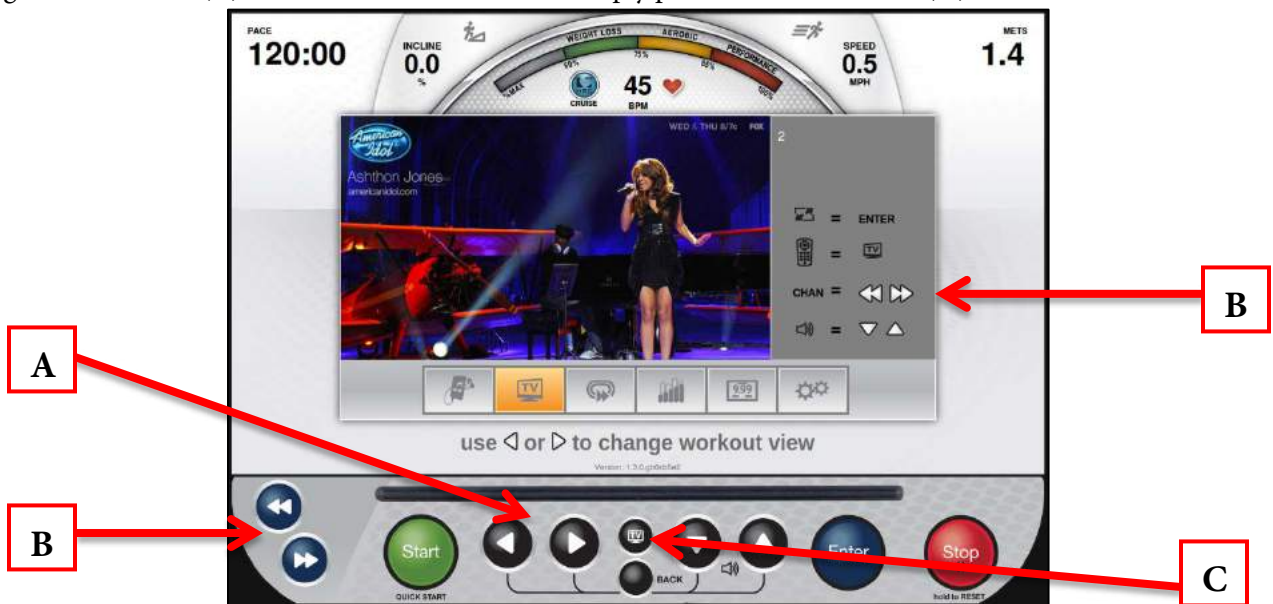

CHAPTER 4B: ESCALATE¹⁵ OPERATION

IPOD® INTEGRATION:

The Escalate¹⁵ console has an advanced iPod® Integration feature which allows a user to enjoy their personal audio and video library when their iPod® is connected to the console via the 30 pin connector located on the front of the console. Once connected, the iPod® menus can be navigated by using the Up/Down Selection Buttons (A) and the Navigation Buttons (B).



During playback, users can control volume by using the Up/Down Selection Buttons (C) and advance or replay tracks by using the navigation buttons (D).



NOTE: Video playback is not available through 30pin to Lightning adapters.



CHAPTER 4B: ESCALATE¹⁵ OPERATION

BLUETOOTH AUDIO:

The Escalate¹⁵ console has integrated Bluetooth support for non-30 Pin iPod® audio devices. To pair a device with the console, use the Left/Right Selection Buttons (A) to select the iPod®/Audio Device Screen. Ensure that the device is discoverable via Bluetooth and press the Enter Button (B) to search for devices.



The console will complete a scan for available Bluetooth devices. Once the scan is complete, use the Up/Down Selection Buttons (C) to select the desired device from the list of available devices and press Enter (D).

*If the device is not listed, verify that it the Bluetooth is enabled and that the device is discoverable. Use the Up/Down Selection Buttons (C) to select Refresh List and Press Enter (D) to re-scan for the Bluetooth device.



CHAPTER 4B: ESCALATE¹⁵ OPERATION

BLUETOOTH AUDIO (CONTINUED):

When a device is selected from the list, the console will send a pairing request to that device. The pairing request must be accepted in order for this feature to operate. For iOS devices, press Pair (E) to accept the request. For Android devices, press Accept (F) to accept the request.

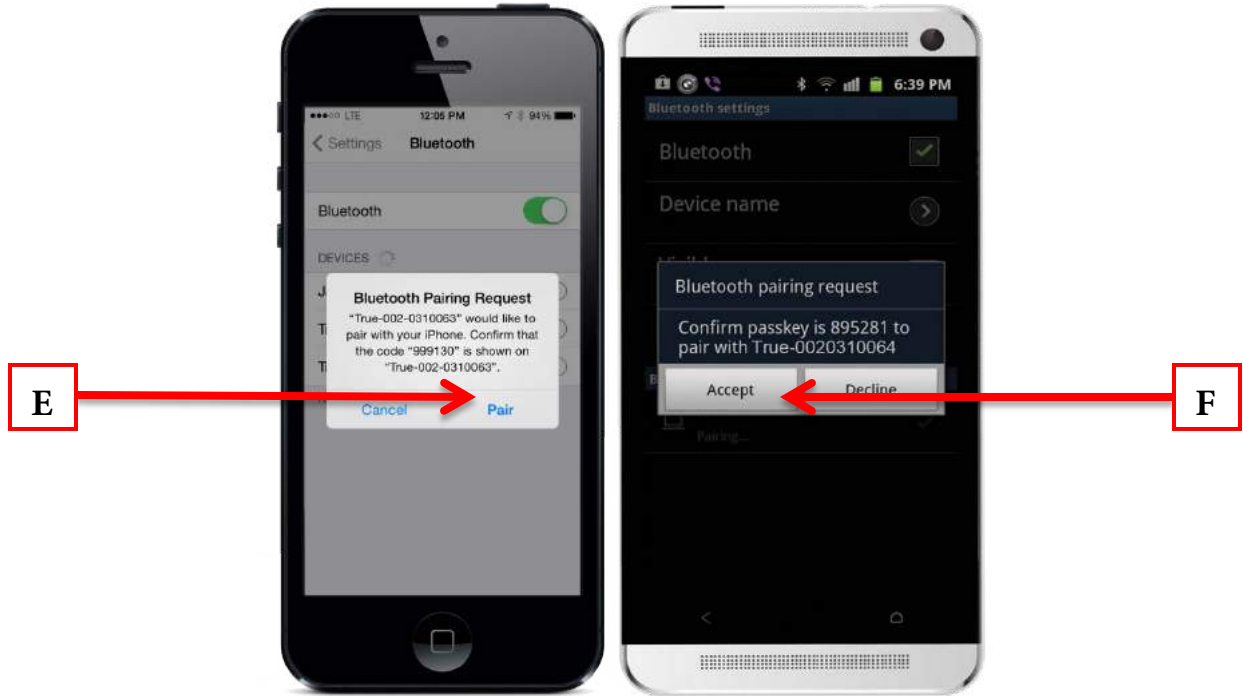

Once the Bluetooth pairing request has been accepted, the playback screen will be displayed. During playback, users can control volume by using the Up/Down Selection Buttons (G) and advance or replay tracks by using the navigation buttons (H).



CHAPTER 4B: ESCALATE¹⁵ OPERATION

ADVANCED CONSOLE FUNCTIONS:

Entering Service Mode:

Entering Service Mode can be completed by pressing and holding the Back navigation Button (A). When the TRUE Logo (B) begins to flash, release the navigation button and press and hold the Enter Button (C).



Main Menu:

After successfully entering service mode the Main Menu will be displayed. From this menu users can access all of the service mode features by navigating through the various menus.

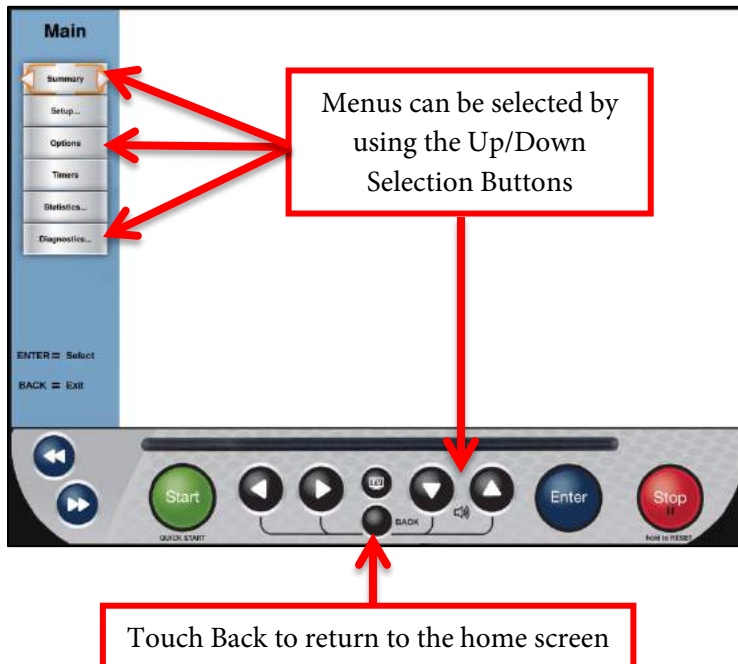

CHAPTER 4B: ESCALATE¹⁵ OPERATION

ADVANCED CONSOLE FUNCTIONS (CONTINUED):

Summary Screen:

The Summary Screen will be the first screen displayed after entering service mode. This screen will give a general overview of the unit's setup.

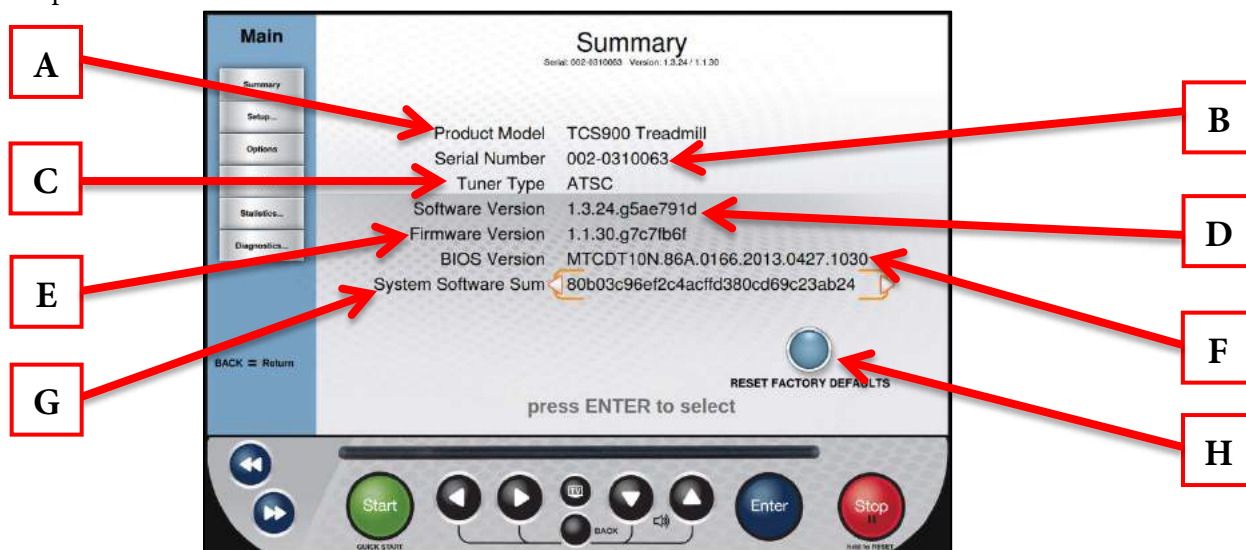

A) Product Model:

The model number that the console is currently configured to.

B) Serial Number:

The serial number of the console (not the base unit).

C) Tuner Type:

The type of TV tuner installed in the console.

D) Software Version:

The current version of software that is installed on the console.

E) Firmware Version:

The current version of firmware that is installed on the console.

F) BIOS Version:

The current BIOS version that is installed on the console.

G) System Software Sum:

Displays OS data that is used in the production of the console.

H) Reset Factory Defaults:

Resets all console settings to their factory defaults.

CHAPTER 4B: ESCALATE¹⁵ OPERATION

ADVANCED CONSOLE FUNCTIONS (CONTINUED):

Setup Menu:

The setup menu is accessed by touching the Setup button on the main menu. The Setup Menu is separated into seven sub-categories and allows to users configure the console and to set up various functions of the unit.

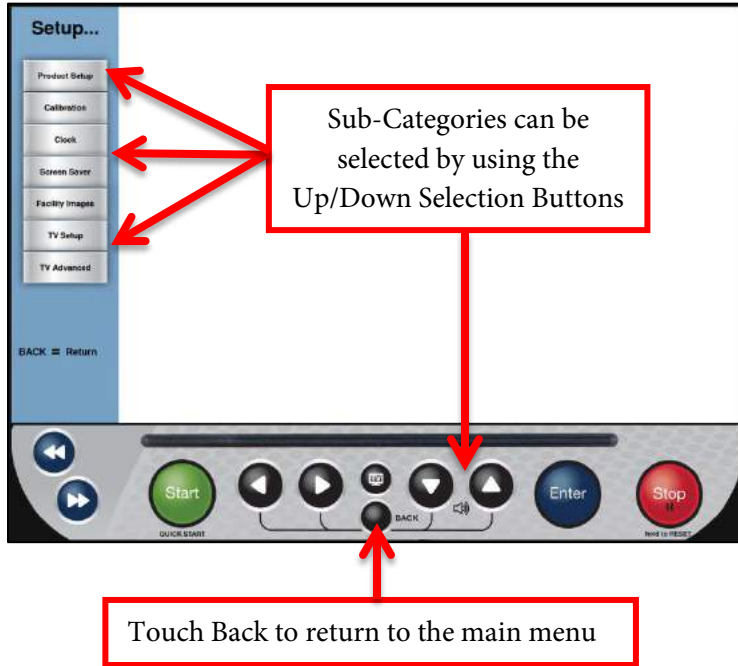

Setup Menu - Product Setup:

The Product Setup screen allows users to change the console configuration to match the unit on which it is installed. To change the console configuration:

- From the Main Menu, select the Setup menu.
- From the Setup Menu, select Product Setup (A).
- Use the Selection Buttons (B) to select the correct model number (C).
- Press the Enter Button (D) to confirm the selection.

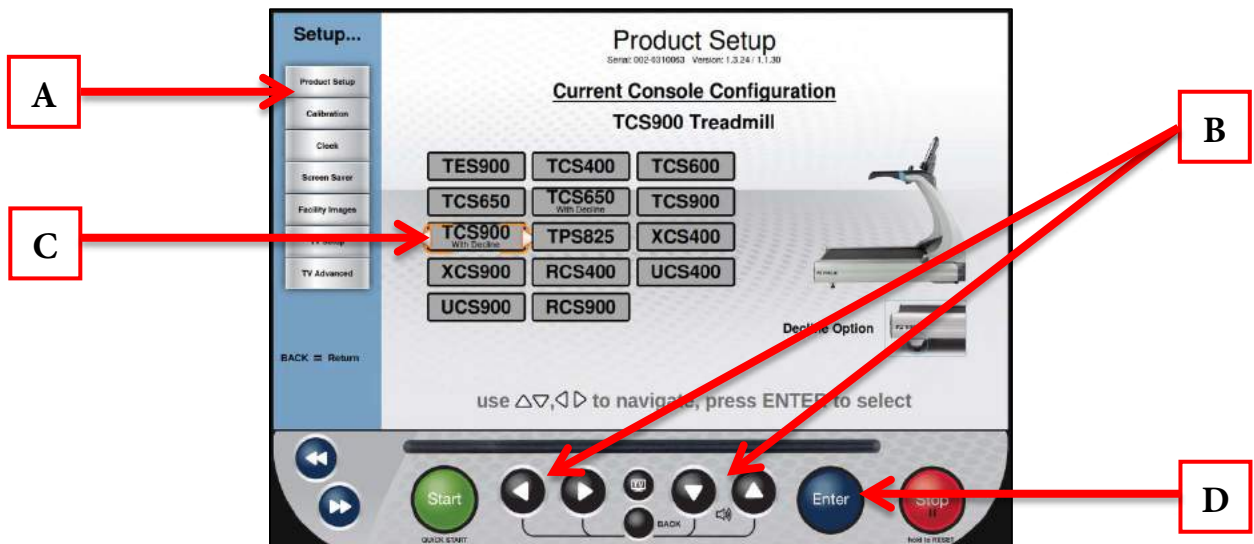

CHAPTER 4B: ESCALATE¹⁵ OPERATION

ADVANCED CONSOLE FUNCTIONS (CONTINUED):

Setup Menu - Calibration:

Calibration will conduct a basic test of the drive and incline systems to ensure that they are operating as intended. Calibration may also be used by technicians to troubleshoot system faults.

⚠️WARNING:

This process will take full control of the treadmill and can be dangerous if caution is not taken.

- Calibration can take up to two minutes to complete.
- Do not stand on the treadmill during the calibration procedure.
- Verify that the machine is free of all parts and tools.
- Keep children and animals at a safe distance.

Calibration Steps:

- From the Main Menu, press the Setup button.
- From the Setup Menu, select Calibration (A).
- Press the Enter Button (B) to begin calibration.
- When complete, the console will display “Calibration Successful”.

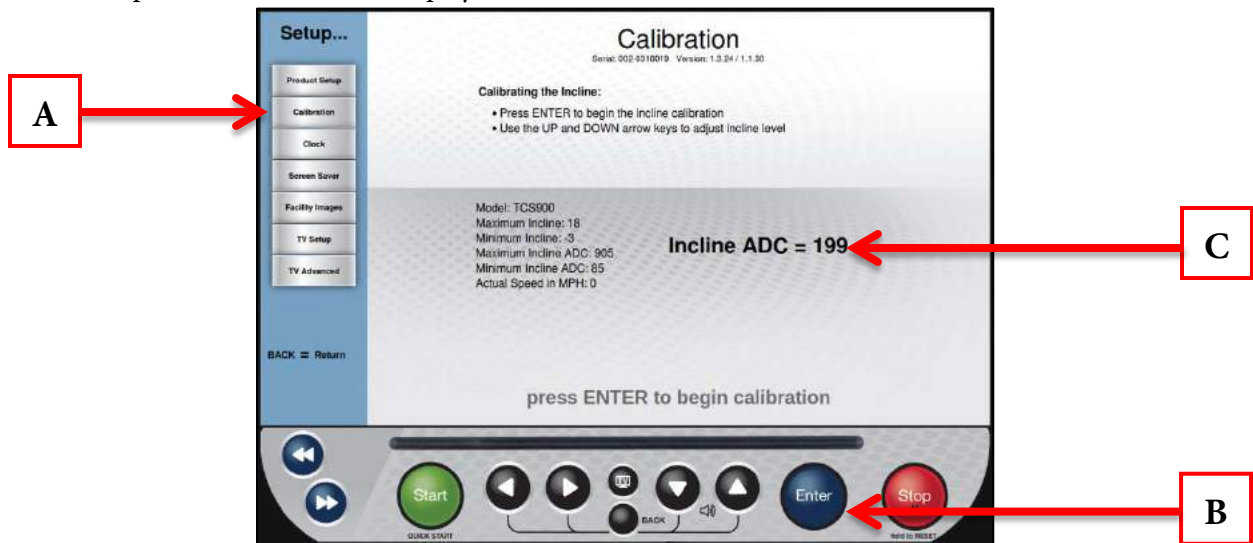

⚠️WARNING:

The Potentiometer Value (C) should only be adjusted by a trained service professional. Any adjustment made to the Potentiometer Value may result in unexpected errors or damage to the incline system.

CHAPTER 4B: ESCALATE¹⁵ OPERATION

ADVANCED CONSOLE FUNCTIONS (CONTINUED):

Setup Menu - Clock:

Correctly setting up the clock will ensure that all workout data that is exported by a user will be correctly labeled. Correct time is also important for troubleshooting purposes when viewing the system's fault log.

Setting the Clock:

- From the Main Menu, select the Setup menu.
- From the Setup Menu, select Clock (A).
- Use the Left/Right Selection Buttons (B) to select the desired value (C).
- Use the Up/Down Selection Buttons (D) to adjust the value to the desired setting.
- Once the correct time and date are entered, select Next (E) and press Enter (F).

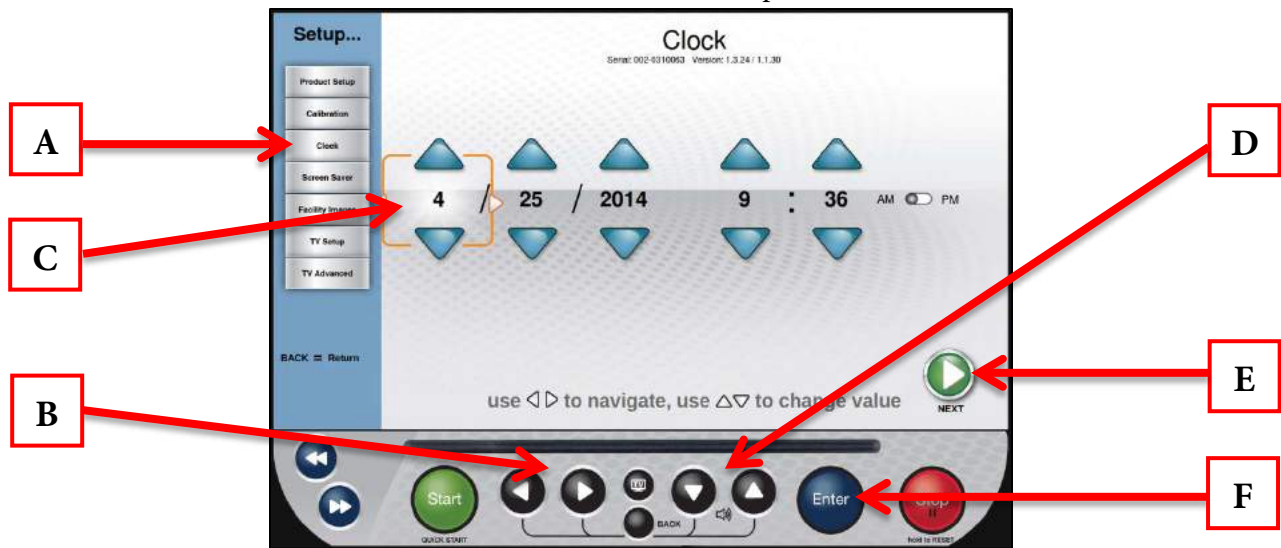

- Use the Up/Down Selection Buttons (G) to scroll through the list of time zones until the correct time zone is shown in bold (H).
- Use the Right Selection Button (I) to highlight Save (J) and press Enter (K).



CHAPTER 4B: ESCALATE¹⁵ OPERATION

ADVANCED CONSOLE FUNCTIONS (CONTINUED):

Setup Menu - Screen Saver:

Users can load JPG images to be used by the console as a custom screen saver. In order to be uploaded to the console, images will need to be placed on a USB drive in a folder named “screen saver” (case sensitive).

Importing Screen Saver Images:

- Select Screen Saver (A) from the Setup Menu and press Enter (B).
- Insert the USB drive that contains the images into the console’s USB port.
- Verify the images in the preview window (C)
- Select Save (D) and press Enter (B) to save the images to the console.



Additional Screen Saver Options:

- Custom Screen Saver images can be deleted by selecting Clear Current Slides (E) and pressing Enter (B).
- The amount of time the console must be idle before the screen saver engages can be adjusted by selecting Screen Saver Time (F) and using the Left/Right Navigation buttons (G) to select the desired time.
- The Sleep timer is a function that will turn off the console’s back light after a period of time to save energy. The amount of time the console must be idle before going to sleep can be adjusted by selecting the Sleep Timer (H) and using the Left/Right Selection Buttons to select the desired time.

⚠️ WARNING:

Setting the Screen Saver Time to zero will disable the screen saver. Disabling the screen saver is not recommended! Doing so may cause damage to the screen and void the manufacturer warranty.

CHAPTER 4B: ESCALATE¹⁵ OPERATION

ADVANCED CONSOLE FUNCTIONS (CONTINUED):

Setup Menu - Facility Images:

The Escalate¹⁵ console supports customizable facility images to help promote specials, events or endorse a brand. In order to be uploaded to the console, images will need to be placed on a USB drive in a folder named “facility” (case sensitive).

Importing Facility Images:

- Select Facility Images (A) and press Enter (B).
- Insert the USB drive that contains the images into the console’s USB port.
- Verify the images in the preview window (C)
- Select Save (D) using the Up/Down Selection Buttons (E) and press Enter (B) to save the images to the console.



* Facility images can be deleted by selecting the Clear (F) and pressing Enter (B).

Once loaded correctly, the facility Images will be displayed in the Facility Workout Data Screen (as shown below).



CHAPTER 4B: ESCALATE¹⁵ OPERATION

ADVANCED CONSOLE FUNCTIONS (CONTINUED):

Setup Menu - TV Setup:

Escalate¹⁵ consoles have an integrated HDTV Tuner which allows the user to watch live programming in crisp, clear high Definition. Before any programming can be viewed, the TV signal needs to be set up. (TV Options will not be displayed on the Home Screen or in the Workout Data Screens until the TV Setup Steps have been completed)

TV Setup Steps:

- From the Setup Menu, select TV Setup (A) and press Enter (D).
- Use the Up/Down Selection Buttons (B) to highlight the type of signal is being used (C). Then press Enter (D) to select the appropriate signal type; Analog, Digital, or Both. (Digital is selected by default)
*When analog is selected the user will need to choose the analog standard (NTSC-M for the United States).
- Highlight the Source Slider (E) and Press Enter (D) to toggle between Antenna and Cable.
- Verify that the correct Country is listed (F).
- Highlight Enable Aux Input (G) and press Enter (D) to Enable or disable the AUX inputs located on the back of the console.
- Highlight Begin Channel Scan (H) and press Enter (D) to begin scanning for channels.



- Once the channel scan is complete, the channel list (I) will be populated with the available channels.



CHAPTER 4B: ESCALATE¹⁵ OPERATION

ADVANCED CONSOLE FUNCTIONS (CONTINUED):

Setup Menu - TV Setup (continued):

Users can save time when setting up multiple units or maintain a back-up of their TV Setup Data by exporting it to a USB drive.

Exporting TV Setup Data to USB:

- Complete the TV Setup process.
- Insert a blank USB drive into the console's USB port.
- When all desired channels are listed in the Channel List (A), use the Up/Down Selection Buttons (B) to highlight Export Scan to USB(C) and press Enter (D).

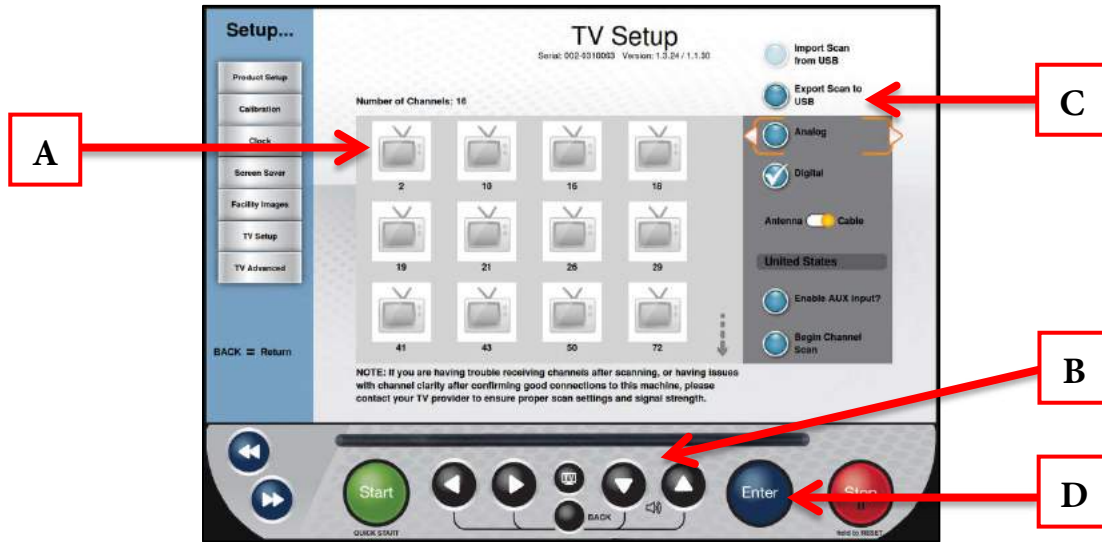

Importing TV Setup Data from USB:

- Navigate to the TV Setup screen.
- Insert the prepared USB stick into the console's USB Port.
- Highlight Import Scan from USB (A) using the UP/Down Selection Buttons (B) and press Enter (C).
- Once the import process is complete, verify that all channels are listed in the channel list (D).



CHAPTER 4B: ESCALATE¹⁵ OPERATION

ADVANCED CONSOLE FUNCTIONS (CONTINUED):

Setup Menu - TV Advanced:

The TV Advanced Menu allows users to fine tune their TV settings by adding channels, removing channels, and adding channel logos.

Add a Channel:

- Navigate to the TV Advanced Screen (A).
- Press the Forward Navigation Button (B) to access the Add Channel Screen.
- Use the Left Right Navigation Buttons(C) to select between the available values (Standard, Frequency, Network, and Channel Number). ***Channel frequencies must be obtained from your television service provider.**
- Use the Up/Down Selection buttons (D) to adjust each value.
- Once all values are correct, press Enter (E) to save the channel



Deleting Channels:

- Highlight the channel to be deleted.
- Press the Back Navigation Button (A)
- Press Enter (B) to delete the selected channel or the forward navigation button (C) to delete all channels



CHAPTER 4B: ESCALATE¹⁵ OPERATION

ADVANCED CONSOLE FUNCTIONS (CONTINUED):

Setup Menu - TV Advanced (continued):

Using Channel logos allows users to quickly identify and select their favorite TV channels with minimal interruption to their workout.

Adding Channel Logos:

- Navigate to the TV Advanced Screen (A).
- Select the desired channel in the Channel List (B) and press the Enter Button (C).

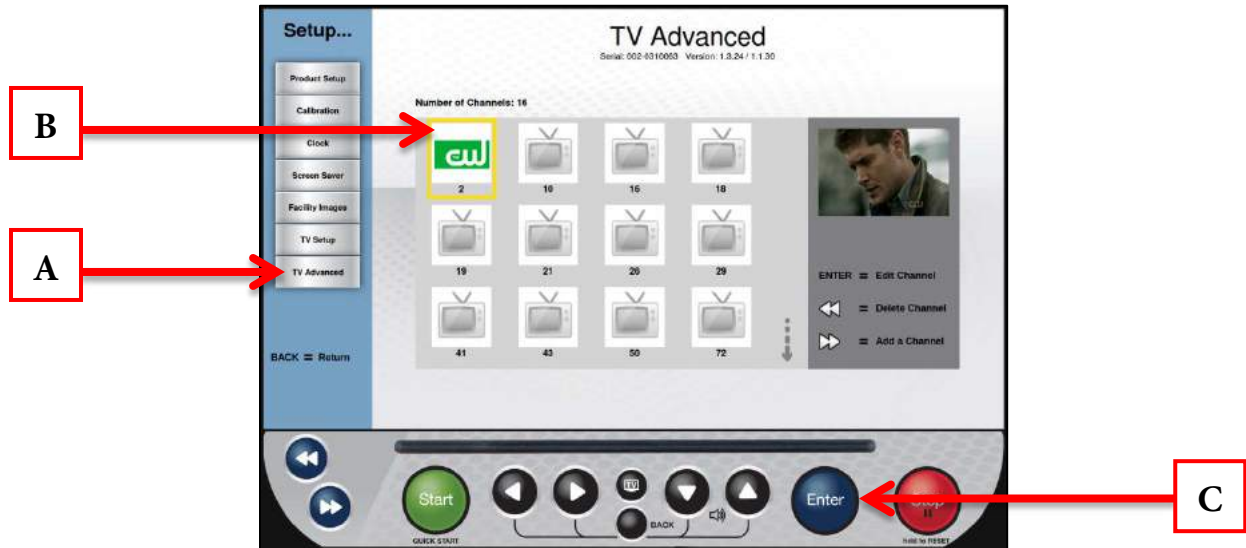

- Select the logo (D) that corresponds to the selected channel and press Enter (C) to save.
- Repeat these steps for each channel for which a logo is available.



CHAPTER 4B: ESCALATE¹⁵ OPERATION

ADVANCED CONSOLE FUNCTIONS (CONTINUED):

Options Menu:

The Options menu allows users to customize settings on the console to meet their needs. Use the Up/Down Selection Buttons (A) to select the desired option and the Left/Right Selection Buttons (B) to adjust the value.

*The settings in this menu save automatically.



C) Metric Units:

When enabled, the console will display all Metric units rather than American Standard.

D) Save Workout Enabled:

Turn on this feature to allow users to save custom workouts to the console.

E) Contact Heart Rate Has Priority:

When enabled, the console will attempt to read heart rate data from the contact heart rate grips before reading data from a wireless chest strap.

*When this option is turned off, telemetry heart rate will take priority.

F) LCD Brightness:

Adjusts the brightness of the TFT display.

G) System Sound Volume:

Adjusts the volume of the notifications and beeps that come from the console.

H) Default Language:

Select a different language. Once a new default language has been selected, all menus, options and workout data will appear in that language.

CHAPTER 4B: ESCALATE¹⁵ OPERATION

ADVANCED CONSOLE FUNCTIONS (CONTINUED):

Timers Menu:

The Timers Menu allows for time limits to be set on various console features and functions. Use the Up/Down Selection Buttons (A) to select the desired option and the Left/Right Selection Buttons (B) to adjust the value.

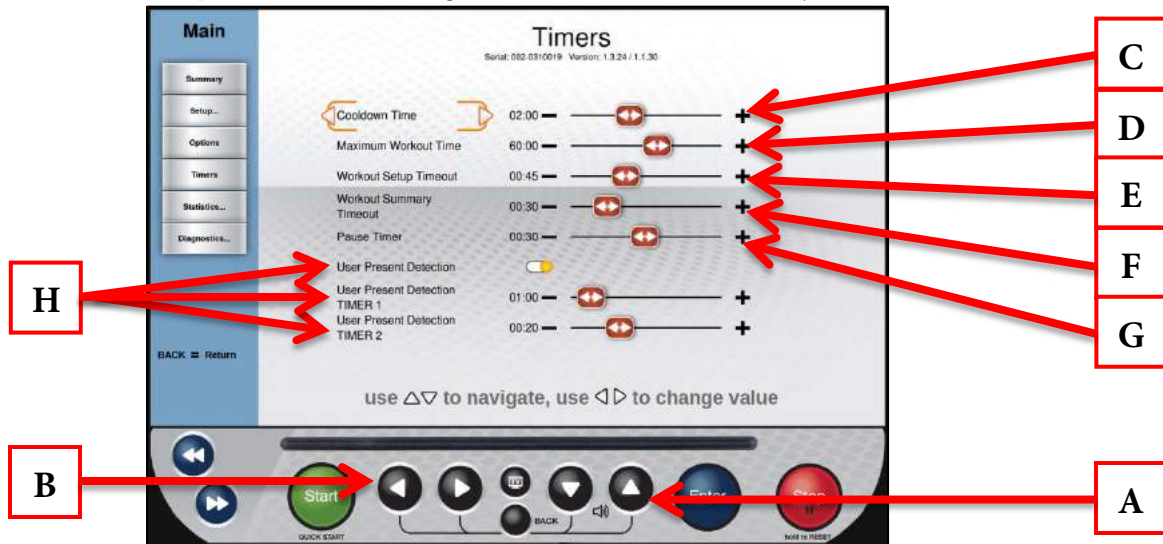

C) Cooldown Time:

Adjusts the length of the cooldown segment at the end of a workout.

D) Maximum Workout Time:

This setting will limit the amount of time that all workouts can last (this setting does not apply to quickstart workouts, manual workouts or distance workouts).

E) Workout Setup Timeout:

Choose how long the workout data entry screen will remain on the display without any user interaction. By choosing the "off" setting, the data entry screen will be displayed until closed by a user.

F) Workout Summary Timeout:

Determines the amount of time the Workout Summary Screen will remain on the display. By choosing the "Off" setting, the summary will be displayed until ended by a user.

G) Pause Timer:

This setting will limit the amount of time that a workout can be paused before it automatically ends. By choosing the "Off" option, the unit will remain paused until the user resumes or ends the workout.

H) User Present Detection (AC drive systems only):

When User Present Detection is enabled the treadmill will pause if it does not detect a normal amp draw which would be indicative of the weight of the user on the treadbelt. Timer 1 will set the amount of time before the console displays a User Present Notification and Timer 2 will set the amount of time that the notification is displayed on the console before the treadbelt is stopped.

CHAPTER 4B: ESCALATE¹⁵ OPERATION

ADVANCED CONSOLE FUNCTIONS (CONTINUED):

Statistics Menu:

The statistics menu provides an overview of how and how long the unit has been used.

Statistics Menu – Summary:

Selecting the Summary screen (A) will provide a usage summary. Run Hours (B) is the total number of hours the unit has been used. Machine Distance (C) is the total distance in miles that the belt has traveled. Distance (D) is the amount of distance the belt has traveled since the last time the Clear Mileage (E) feature was used.

*The Distance/Clear Mileage feature is helpful for tracking mileage in a preventive maintenance schedule.



Statistics Menu – Program Usage:

Selecting the Program Usage screen (A) will provide a list of programs that have been used on the unit and how many times those programs have been used. These statistics can be reset by highlighting the Clear button (B) and Pressing Enter (C), but it is not recommended.



CHAPTER 4B: ESCALATE¹⁵ OPERATION

ADVANCED CONSOLE FUNCTIONS (CONTINUED):

Diagnostics Menu:

The Diagnostics Menu contains tools used to help diagnose errors and performance issues.

Diagnostics Menu-Tests:

The Tests Screen is used by technicians to aid in troubleshooting and contains commonly used troubleshooting tests.

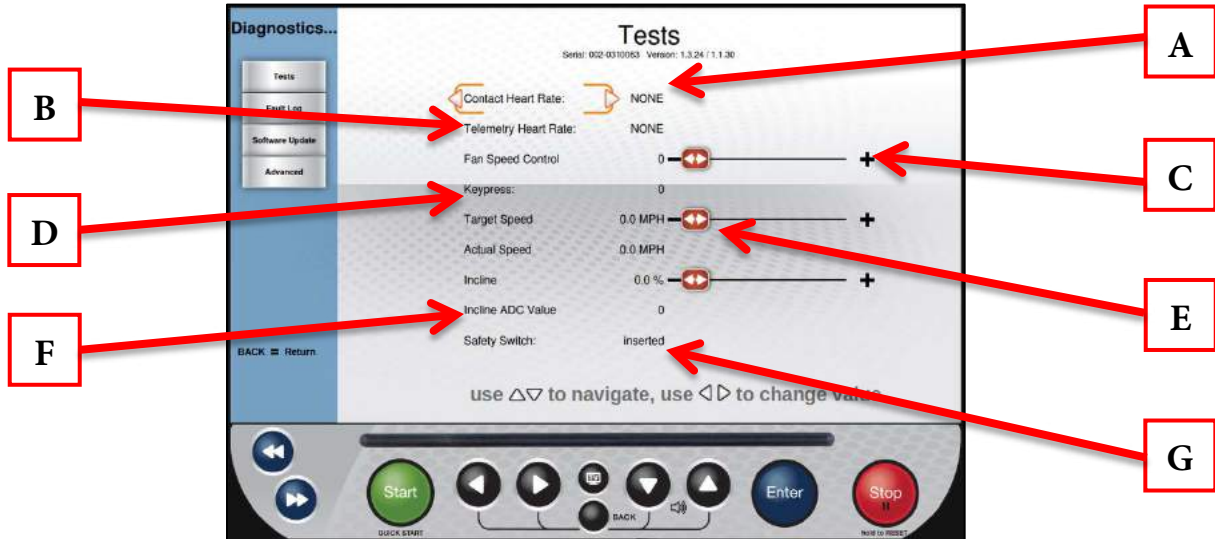

A) Contact Heart Rate:

Ensures the unit is receiving the data by displaying the user's heart rate when the contact heart rate pads are gripped.

B) Telemetry Heart Rate:

Use a wireless heart rate strap or simulator to test if the unit is receiving wireless heart rate data. If there is a reading displayed without the use of a heart rate strap or simulator, there is outside interference from another source.

*This unit is designed to receive 5 khz non-coded transmissions only.

C) Fan Speed Control:

Allows users to test the fan independent of a program.

D) Keypress:

When a quick access key is pressed on the unit, "NONE" will change to indicate which key is being pressed. In the event of a stuck key, the key that is being engaged will display.

E) Target Speed/Actual Speed:

Commands the treadbelt to move and verifies that the belt is moving at the commanded speed using the actual speed readout.

F) Incline/Incline ADC Value:

Used to troubleshoot incline system faults by commanding the unit to incline and reading the Incline ADC Value.

G) Safety Switch:

Used to verify that the console is able to read the safety key.

CHAPTER 4B: ESCALATE¹⁵ OPERATION

ADVANCED CONSOLE FUNCTIONS (CONTINUED):

Diagnostics Menu - Fault Log:

The Fault Log (A) will display a time stamped list of recent fault codes that can be helpful in the troubleshooting process. The Fault Log can be exported to a USB drive by highlighting Export (B) and pressing Enter (C). The log can also be reset by highlighting Clear (D) and pressing Enter (C), but it is not recommended.

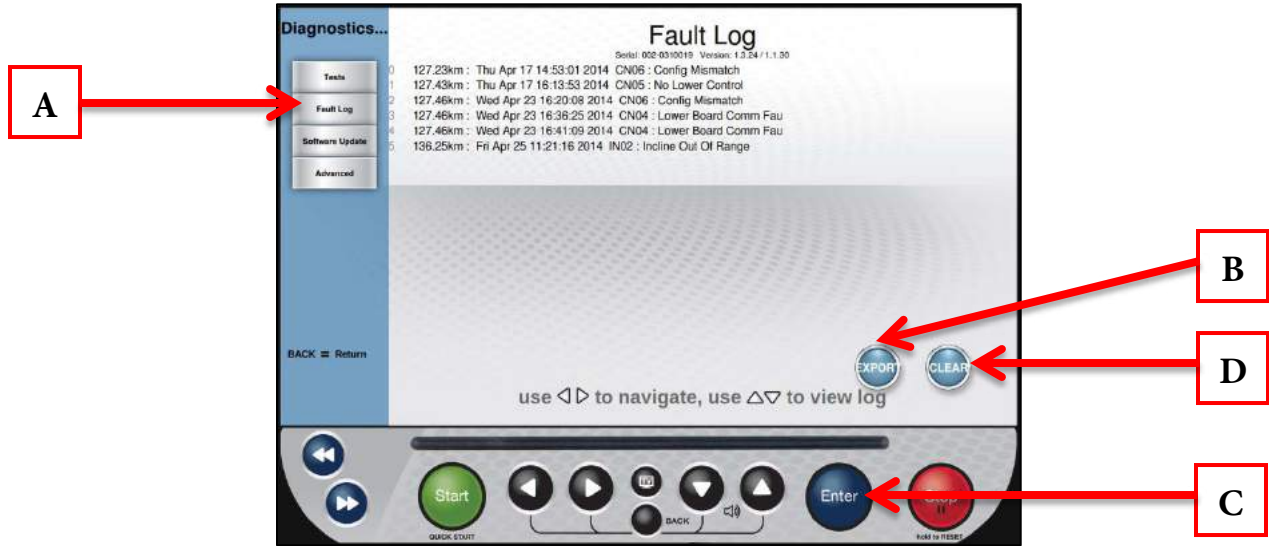

Diagnostics Menu - Software Update:

TRUE may periodically release software updates to ensure users enjoy the best workout experience available. To update the console software, download the update program (A) from truefitness.com and load the software to a blank USB drive by following the downloadable instructions.

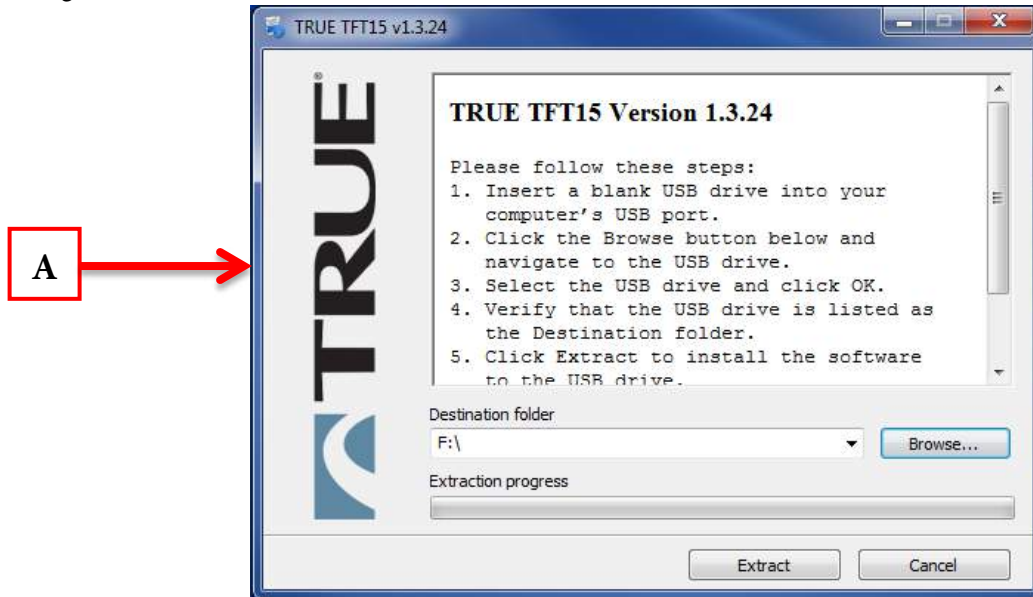

⚠️ WARNING:

Disconnecting the power source, switching the unit off or pressing buttons on the console will disrupt the information flow and potentially cause fatal errors.

CHAPTER 4B: ESCALATE¹⁵ OPERATION

ADVANCED CONSOLE FUNCTIONS (CONTINUED):

Diagnostics Menu - Software Update (continued):

- Insert the USB drive containing the software update into the console's USB port.
- From the Diagnostics Menu, use the Up/Down Selection Buttons to highlight Software Update and press the Enter Button (A).
- When the console locates the software update, highlight Update Software (B) and press Enter.

NOTE: Do not power cycle the unit between the software and firmware updates

- After the installation of the software update, highlight Load Firmware (C) and press Enter.
- Following the installation of the software and firmware, power cycle the unit to finalize the software update.

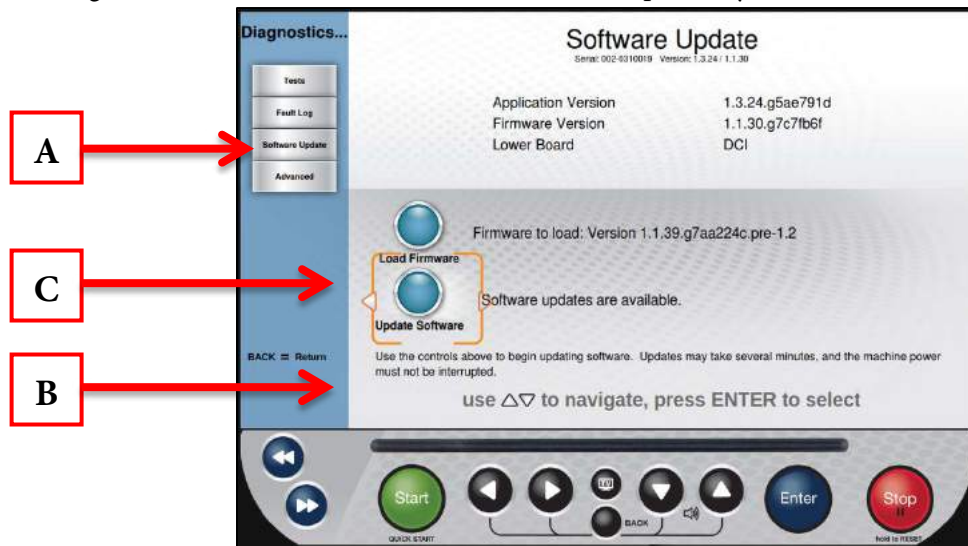

Diagnostics Menu - Advanced:

The advanced screen contains multiple tools that are used in the production of the console and for demonstration purposes. It is recommended to leave these settings in their default positions.

CHAPTER 4C: ESCALATE⁹ OPERATION

ESCALATE⁹ OVERVIEW:



CHAPTER 4C: ESCALATE⁹ OPERATION

ESCALATE⁹ OVERVIEW (CONTINUED):

TFT Display:

Used to monitor or control a work out and feature navigation.

Selection Keys:

Used to navigate menus and make selections via the TFT Display.

Incline Keys:

Manually increases or decreases the incline of the treadmill.

Start:

Allows the user to begin a Quick Start workout or preset workout.

Reading Rack:

A ledge on the console can be used to hold a book, magazine, e-reader, or tablet computer during a workout.

USB Port:

Allows users to export workout data to an external USB drive or update the console software.

Numeric Keypad:

A small panel of keys on the console that allow the user to quickly enter numeric data.

Headphone Jack:

Standard 3.5mm audio jack used to connect headphones to the console during media playback.

30 Pin iPod® Connector:

Standard 30 pin iPod connector used to connect an iPod to the console.

Warning Decal:

Important safety information for users to review prior to using the equipment.

Stop:

Stops/Pauses a workout. Press and hold this key for five seconds to reset the unit.

Speed Keys:

Manually increases or decreases the speed of the belt.

CHAPTER 4C: ESCALATE⁹ OPERATION

CONSOLE NAVIGATION:

Home Screen:

The Home Screen is displayed on the console when there is no workout in progress. From this screen the user is able to select from various options to begin a workout.



A) Workout Finder

Displays preset workout selections by category

B) Quick Start

Starts a Quick Start workout in which the user controls all settings until the workout is ended by the user.

C) Language Options

Allows users to choose between 12 language options.

CHAPTER 4C: ESCALATE⁹ OPERATION

CONSOLE NAVIGATION (CONTINUED):

Selecting a Preset Workout:

Preset workouts are accessed by selecting Workout Finder from the home screen. To view the workouts in a category, select the category (A) by using the Scroll Selection Buttons (B) and then press the Next Selection Button (C).

*Press and hold the Next Selection Button to return to the previous screen.



Workout Data Entry Screens:

These screens allow users to input their personal information or workout goals prior to beginning a workout. To set a value, press the Selection Button for the value you wish to change (A) and use the + and - keys (B) to adjust the value to the desired setting. Users may also manually enter a value using the Numeric Keypad (C).

*Workout Data Entry Screens vary by program selection.

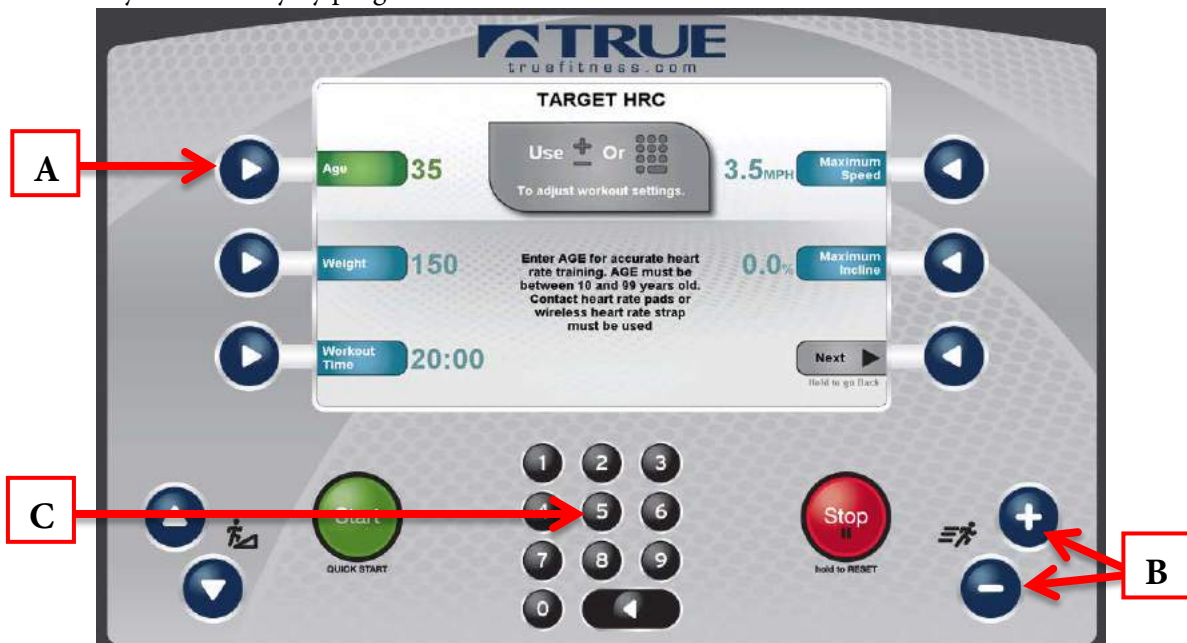

CHAPTER 4C: ESCALATE⁹ OPERATION

CONSOLE NAVIGATION (CONTINUED):

Workout Data Screens:

During any workout a Workout Data Screen will be displayed to give the user a comprehensive visual overview of their current workout data.

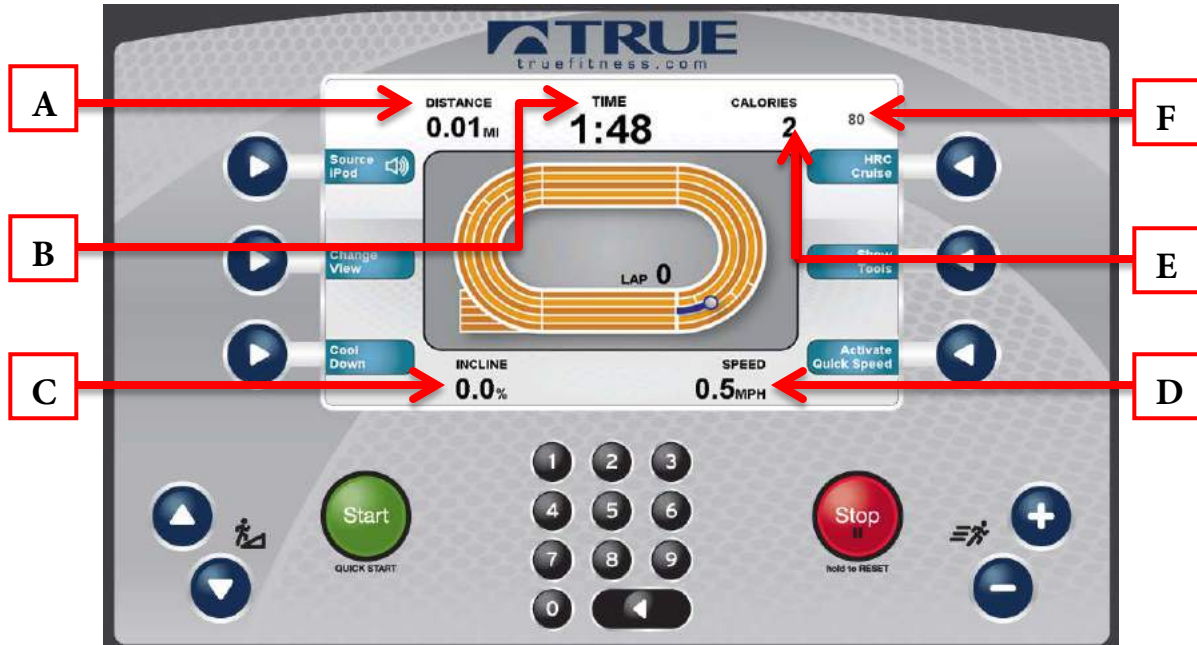

A) Custom Data Display #1:

By Default, this display will show the distance for the current workout. Users can also choose custom data points to be seen in this display.

*See Workout Data Screen Controls; F) Show Tools section.

B) Time:

Displays the time elapsed for the current workout.

C) Incline:

Shows the current incline of the treadmill.

D) Speed:

Shows the current speed of the treadmill belt.

E) Custom Data Display #2:

By Default, this display will show the calorie count for the current workout. Users can also choose custom data points to be seen in this display.

*See Workout Data Screen Controls; F) Show Tools section.

F) Heart Rate:

Shows the user's heart rate in a digital beats per minute (bpm) readout.

CHAPTER 4C: ESCALATE⁹ OPERATION

CONSOLE NAVIGATION (CONTINUED):

Workout Data Screen Controls:

The Workout Data Screens contain various controls that allow users to adjust workout settings and to customize their overall workout experience. These controls are accessed by pressing the Selection Button for the control they wish to use.



A) Change View:

Switches between the available Workout Data Screens

B) Cool Down:

Pressing this button allows the user to end their current workout with a two minute low intensity cool down period. When Cool Down is activated the unit is in manual mode and the user directly controls all settings.

C) HRC Cruise:

Engages Heart Rate Control to allow the equipment to maintain the user's current heart rate through automatic speed and incline adjustments (when the user is utilizing heart rate monitoring).

CHAPTER 4C: ESCALATE⁹ OPERATION

CONSOLE NAVIGATION (CONTINUED):

D) Source:

Toggles the iPod® audio source on and off (when connected via the 30 pin iPod connector). When an audio source is selected the user is given control over volume (A), and track adjustments (B).



E) Activate Quick Speed:

When the Activate Quick Speed Selection Button is pressed, various preset speeds will appear. Pressing one of the Speed Selection Buttons (A) will allow the user to quickly and conveniently switch to that preset speed. To return to the Workout Data Screen press the Exit Quick Speed Selection Button (B)



CHAPTER 4C: ESCALATE⁹ OPERATION

CONSOLE NAVIGATION (CONTINUED):

F) Show Tools:

Pressing the Show Tools Selection Button (A) will display various options. Pressing the Change Data Selection Button (C) will toggle the data points in Custom Data Display 1(1) between distance and pace. The data in custom data display 2 (2) will toggle between calories and METs. Pressing the Scroll Data Selection button (B) will allow the Custom Data Displays to automatically toggle between data. Pressing the Unit Selection Button (D) will change the units displayed between English and Metric.



Workout Summary Screen:

At the end of a workout the Summary Screen will display an overview of the workout data. The workout data can be exported to another device by inserting a USB drive into the console's USB port and pressing the Save Selection Button (A) or to return to the home screen press the Home Selection Button (B)



CHAPTER 4C: ESCALATE⁹ OPERATION

ADVANCED CONSOLE FUNCTIONS:

Entering Service Mode:

Entering Service Mode can be completed by pressing and holding the upper left selection button (A) for 3-5 seconds or until the “Workout Finder” icon (B) blinks. When the “Workout Finder” icon blinks, release and hold the “Workout Finder” selection button (C) until the service screen displays.

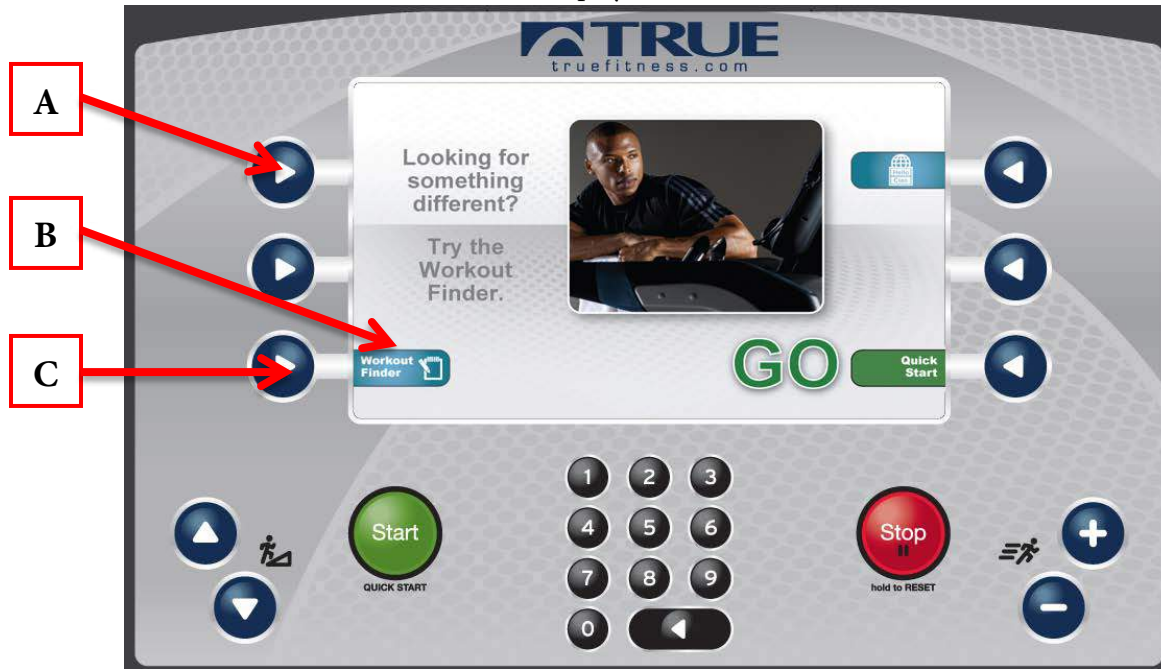

Service Menu:

The first screen displayed after entering service mode is the Service Menu. From this menu technicians can access all of the service mode features by selecting different categories. To select a category use the scroll selection buttons (A) to highlight a category (B). Once a category has been selected, press the enter selection button (C) to Confirm the selection.

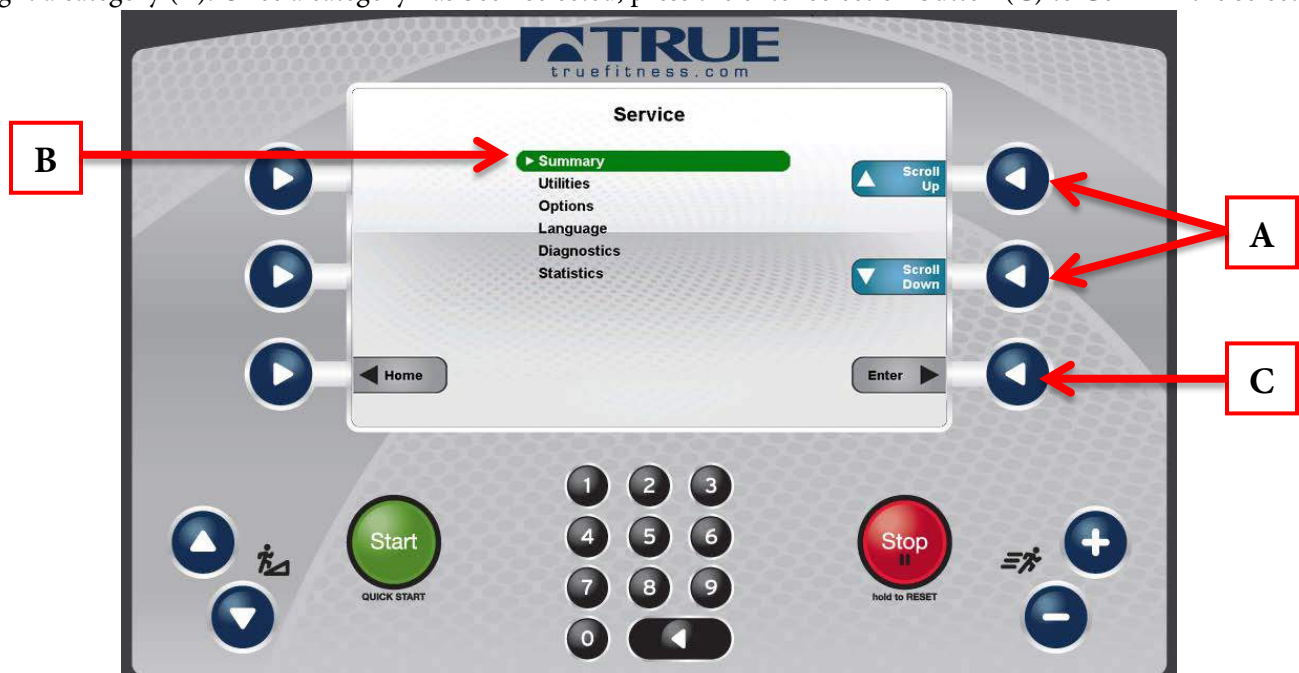

CHAPTER 4C: ESCALATE⁹ OPERATION

ADVANCED CONSOLE FUNCTIONS (CONTINUED):

Summary Screen:

The Summary Screen provides an overview of the unit's current settings (values cannot be changed in this screen).



A) Product Model:

The model number that the console is currently configured to.

B) Software Version:

The current version of software that is installed on the console.

C) Units:

Displays the units the console is currently using as default (U.S. or Metric).

D) Max Speed:

The maximum speed the unit is able to reach.

E) Min Speed:

The minimum Speed the unit is able to maintain.

F) Max Incline:

The maximum percentage that the unit can be inclined.

G) Min Incline:

The minimum percentage that the unit can be inclined.

H) Max User Weight:

The amount of user weight that the unit can support.

CHAPTER 4C: ESCALATE⁹ OPERATION

ADVANCED CONSOLE FUNCTIONS (CONTINUED):

Utilities Menu:

The utilities menu contains multiple screens that allow the technician to change various console settings. Settings are broken down in to three categories. To adjust settings, highlight a category (A) by using the scroll selection buttons (B) and pressing the enter selection button (C) to confirm the selection.



Utilities Menu - Product Setup:

The product setup screen allows the technician to adjust model configuration, incline range, and speed range. TRUE's recommendation is to only use the Setup Wizard to adjust these attributes. After pressing the Setup Wizard Selection Button (A), simply follow the on screen instructions to complete the setup procedure

⚠️ WARNING:

Misconfiguration of the console may cause damage to the unit and void the manufacturer warranty. If necessary, please contact TRUE Fitness Technical Support at 800-883-8783 for assistance.

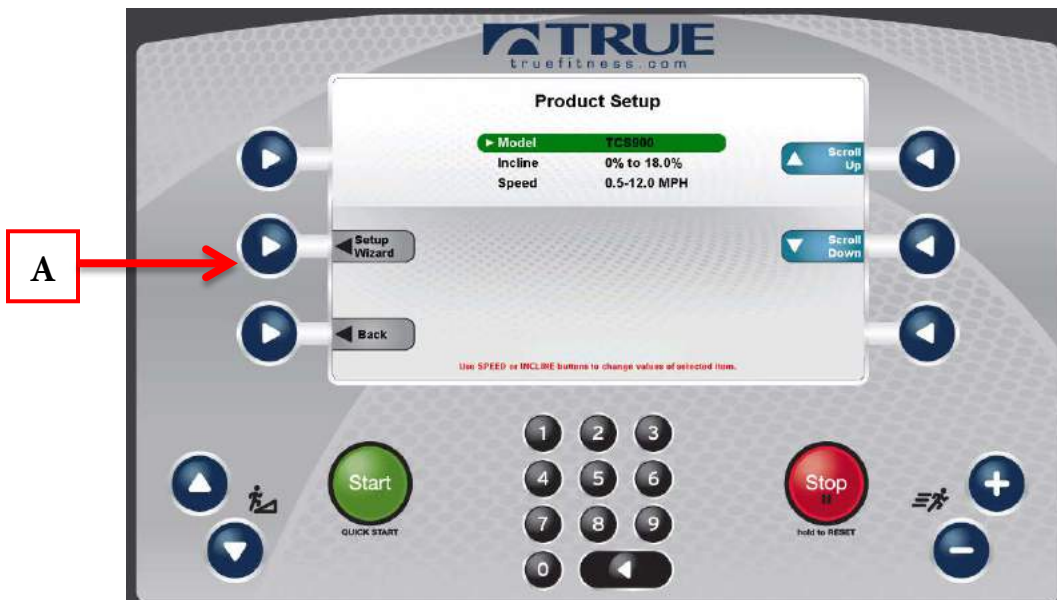

CHAPTER 4C: ESCALATE⁹ OPERATION

ADVANCED CONSOLE FUNCTIONS (CONTINUED):

Utilities Menu - Software Update:

TRUE may periodically release software updates to ensure users enjoy the best workout experience available. To update the console software, download the update program (A) from truefitness.com and load the software to a blank USB drive by following the downloadable instructions.

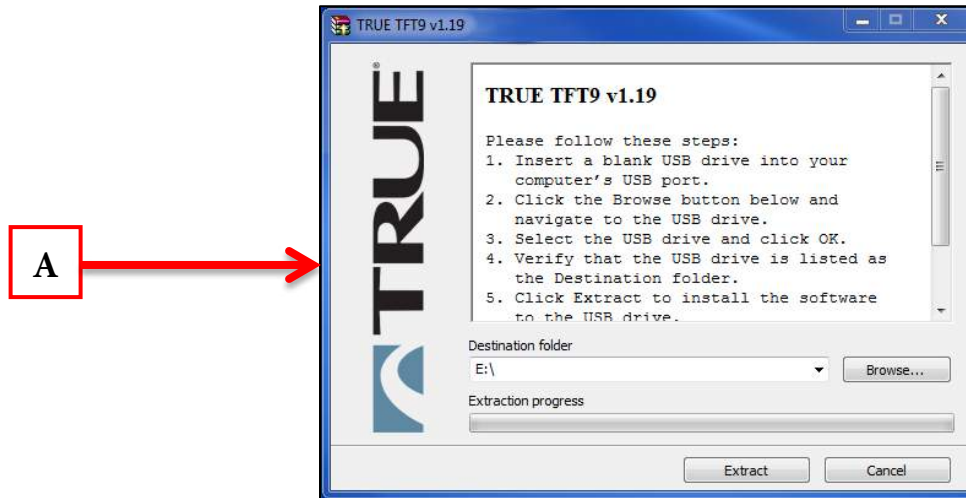

Navigate to the software update screen and insert the prepared USB drive into the console's USB port. When the console recognizes the software it will show a message that reads "Drive found and ready. Press Update to begin. Warning: Improper use can render this machine inoperable". To complete the update, press the update selection button (A).



⚠️ WARNING:

Disconnecting the power source, switching the unit off or pressing buttons on the console will disrupt the information flow and potentially cause fatal errors.

Utilities Menu - B-Vision Setup:

This feature is not available on the ES900 Treadmill

CHAPTER 4C: ESCALATE⁹ OPERATION

ADVANCED CONSOLE FUNCTIONS (CONTINUED):

Options Menu:

The options menu contains 12 Settings with various options available for each. For a complete list of settings and options, please refer to the table on the next page. To navigate the options menu, use the scroll selection buttons (A) to highlight the option to be changed (B) and use the speed keys (C) or incline keys (D) to adjust the options. Once the changes are complete, press the back selection button (E) and the changes will be automatically saved.

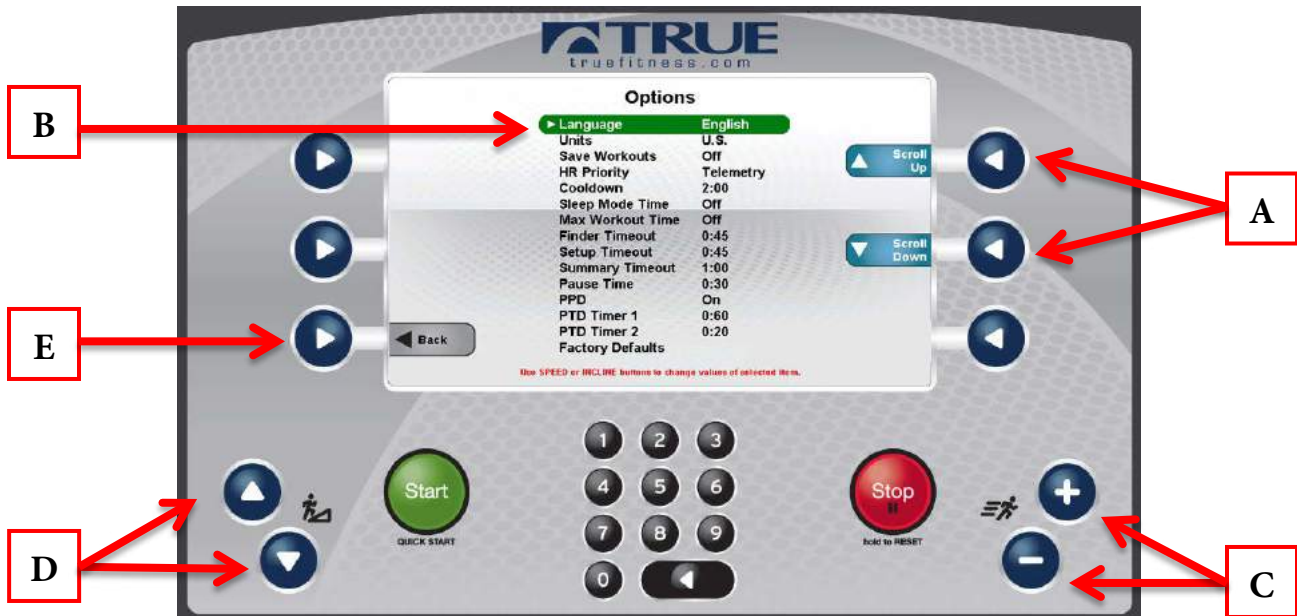

Language:

Select a default Language for the unit. All settings and workout data will be displayed in that language.

Units:

Choose how the workout data is displayed by default.

Save Workout:

Turns the saved workout feature on or off.

Heart Rate Priority:

Determines the order in which the unit reads heart rate data.

Cooldown:

Adjusts the length of the cooldown time at the end of a workout.

Sleep Mode Time:

The amount of time the unit can be idle before entering sleep mode. By choosing the “Off” setting, the unit will remain powered.

CHAPTER 4C: ESCALATE⁹ OPERATION

ADVANCED CONSOLE FUNCTIONS (CONTINUED):

Options Menu (continued):

Max Workout Time:

This setting will limit the amount of time that all workouts can last. By choosing the “Off” setting, the time will be unlimited (this setting does not apply to manual workouts or distance workouts).

Finder Timeout:

Choose how long the Workout Finder remains on the screen without any user interaction. By choosing off, the Workout finder will stay open until closed by a user.

Setup Timeout:

Choose how long the workout data entry screen will remain on the display without any user interaction. By choosing the “off” setting, the data entry screen will be displayed until closed by a user

Summary Timeout:

Determines the amount of time the Workout Summary Screen will remain on the display. By choosing the “Off” setting, the summary will be displayed until ended by a user.

Pause Time:

This setting will limit the amount of time that a workout can be paused before it automatically ends. By choosing the “Off” option, the unit will remain paused until the user resumes or ends the workout.

Factory Defaults:

Resets all settings in the options menu to factory defaults.

Diagnostics Menu:

The diagnostics menu contains tools used to help diagnose errors and performance issues. The tools are broken down into three categories. To use a tool, highlight a category (A) by using the scroll selection buttons (B) and pressing the enter selection button (C) to confirm the selection.

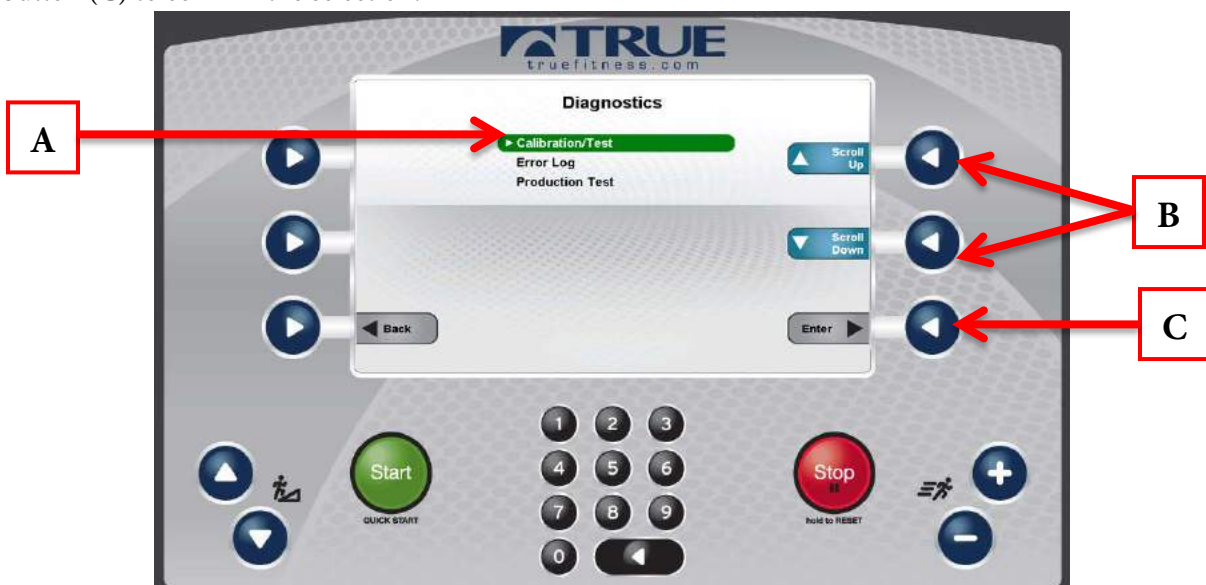

CHAPTER 4C: ESCALATE⁹ OPERATION

ADVANCED CONSOLE FUNCTIONS (CONTINUED):

Diagnostics Menu - Calibration/Test:

This menu contains tools for testing and verifying treadmill operation.



A) Key Test:

When a key is pressed on the console “NONE” will change to indicate which key is being pressed. In the event of a stuck key, the key that is being engaged will display (the selection buttons are excluded from this test).

B) Telemetry HR:

Use a wireless heart rate strap or simulator to test if the unit is receiving wireless heart rate data. If there is a reading displayed without the use of a heart rate strap or simulator, there is outside interference from another source.

C) Contact HR:

Ensures the unit is receiving the data by displaying the user’s heart rate when the contact heart rate pads are gripped.

D) Speed/Incline Cal:

Speed/Incline Cal (calibration) is selected by default in this menu. To run a calibration press the enter selection button (E) and then follow the on screen instructions.

⚠️ WARNING:

This process will take full control of the treadmill and can be dangerous if caution is not taken.

- Calibration can take up to two minutes to complete.
- Do not stand on the treadmill during the calibration procedure.
- Verify that the machine is free of all parts and tools.
- Keep children and animals at a safe distance.

Production Test:

The production test screen is used during the production process and is not used for service or troubleshooting.

CHAPTER 4C: ESCALATE⁹ OPERATION

ADVANCED CONSOLE FUNCTIONS (CONTINUED):

Diagnostics Menu - Error Log:

Error codes are an important part of troubleshooting any issues with the treadmill. Any time an error occurs it is entered into the error log for review by a service professional. This console is capable of storing the ten most recent errors. The error log can be cleared by pressing the enter selection button (A), but it is not recommended.



Statistics:

The statistics menu displays an overview of the treadmill's running data. The overview includes distance, time, average speed, maximum speed, manual program count, preset program count, and apple device connections. These statistics can be exported to a connected USB drive by using the scroll selection buttons (A) to highlight the USB Export option (B) and pressing the enter selection button (C). The data can be cleared by selecting Clr Dist/Time/Spd (D) or Clr Man/Prog/Apple (E), but it is not recommended.

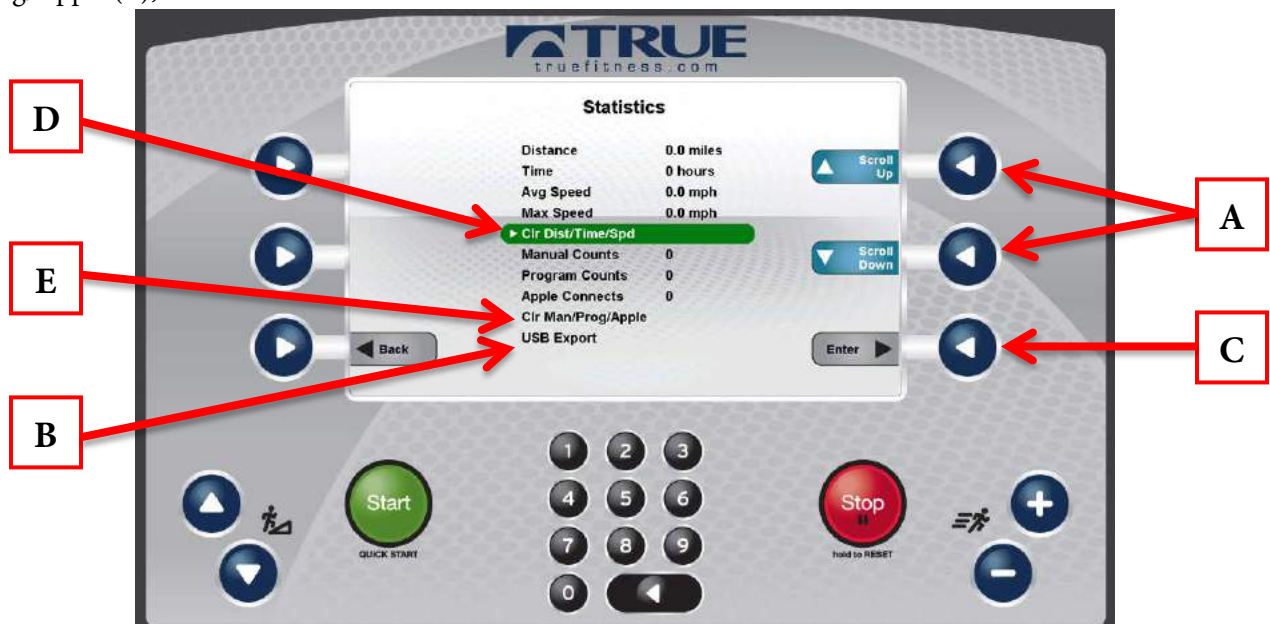

CHAPTER 5: CARE & MAINTENANCE

CARE & MAINTENANCE:

It is important to perform the minor maintenance tasks described in this section. Failure to maintain the treadmill as described here could void the TRUE Fitness Warranty. To reduce the risk of electrical shock, always unplug the unit from its power source before cleaning or performing any maintenance tasks.

Inspection:

TRUE Fitness is not responsible for performing or scheduling regular maintenance or inspections. Users should inspect the treadmill daily. Check for worn, frayed or missing safety lanyards. Replace missing or worn safety lanyards immediately. Do not exercise on the treadmill without attaching the safety clip to your clothing. Look and listen for slipping belts, loose fasteners, unusual noises, worn or frayed power cords, and any other indications that the equipment may be in need of service. If any of these are noticed, obtain service. Do not attempt to use the treadmill until proper service has been performed or damaged parts have been replaced.

Important:

If you determine that the treadmill needs service, make sure that the treadmill cannot be used inadvertently. Turn the unit off, and then unplug the power cord from its power source. Remove the magnetic safety key and safety clip and store it in a safe place. Make sure other users know that the treadmill needs service.

*To order parts or to contact a TRUE Authorized Service representative, please visit www.truefitness.com.

CLEANING THE EQUIPMENT:

After Each Use:

- Use GymWipes™ Antibacterial wipes or spray a solution of 30 parts water to 1 part mild detergent to dampen a soft cloth and wipe all exposed surfaces.
- Use a LCD/screen cleaner or spray a solution of 1 part 91% isopropyl alcohol and 1 part water to dampen a soft cloth and wipe the surface of the console. This helps remove fingerprints, dust, and dirt.

Weekly:

- Vacuum any dust or dirt that might have accumulated under or around the treadmill, any motor cover vents and under the straddle covers. Clogged air vents can prevent adequate cooling to the drive motor, incline motor, and motor control board causing a shortened life.
- Check for proper running belt alignment and tension. If running belt adjustment is required see sections RUNNING BELT ALIGNMENT: and TENSIONING THE RUNNING BELT: below.

CAUTION:

Do not use any acidic cleaners. Doing so will weaken the paint or powder coatings and may void the TRUE Fitness Warranty. Never pour water or spray liquids on any part of the treadmill. Allow the treadmill to dry completely before using. Frequently vacuum the floor underneath the unit to prevent the accumulation of dust and dirt, which can affect the smooth operation of the unit. Use a soft nylon scrub brush to clean the running belt. Do not clean directly underneath the treadbelt. Most of the working mechanisms are protected inside the motor cover and base of the treadmill. However, for efficient operation, the treadmill relies on low friction. To keep the friction low, the unit's running belt, staging platforms, and internal mechanisms must be as clean as possible.

CHAPTER 5: CARE & MAINTENANCE

RUNNING BELT ALIGNMENT:

Proper belt alignment allows the belt to remain centered and ensures smooth operation. Realigning the belt takes a few simple adjustments. If you are unsure about this procedure, call the TRUE Service Department.

⚠ CAUTION:

Special care must be taken when aligning the running belt. Turn off the treadmill while adjusting or working near the rear roller. Remove any loose clothing and tie back your hair. Be very careful to keep your fingers and any other object clear of the belt and rollers, especially in front of the roller and behind the deck. The treadmill will not stop immediately if an object becomes caught in the belt or rollers.

⚠ CAUTION:

If you hear any chafing or the running belt appears to be getting damaged, stop the running belt immediately by pressing the STOP key. Contact the TRUE Service Department. Walk around to the rear of the unit and observe the belt for a few minutes. The belt should be centered on the running deck. If the belt drifts off center, you must make adjustments.

Important:

Failure to align the belt may cause the belt to tear or fray, which may not be covered under the TRUE Fitness Warranty. To stop the running belt, press the STOP key. Turn the treadmill off.

⚠ CAUTION:

For your safety, use the power switch to turn off the treadmill before making any adjustments. Do not adjust the running belt when someone is standing on the unit.

⚠ CAUTION:

Do not turn the adjusting bolt more than $\frac{1}{4}$ turn at a time. Over tightening the bolt can damage the treadmill. If you are unsure how to adjust the running belt, call the TRUE Service Department.

If the running belt is too far to the right side:

- Locate the belt adjustment bolts in the rear end caps of the treadmill. (To determine left and right, stand at the rear of the treadmill and face the display).
- Using the appropriate size Allen wrench or socket turn the RIGHT adjustment bolt clockwise $\frac{1}{4}$ turn.
- Turn the treadmill on and start the belt at 3mph keeping off the unit.
- Allow 2 minutes for the belt to adjust itself.
- Repeat the above steps if additional adjustment is necessary.

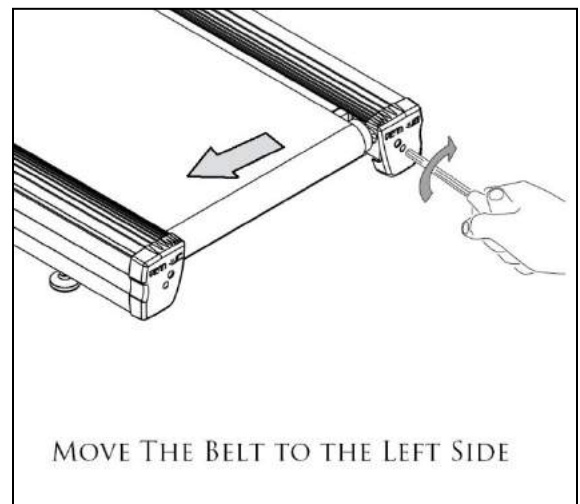

CHAPTER 5: CARE & MAINTENANCE

RUNNING BELT ALIGNMENT (CONTINUED):

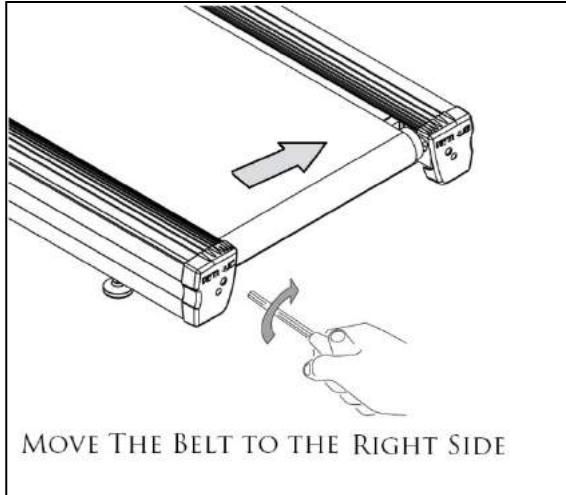

If the running belt is too far to the left side:

- Locate the belt adjustment bolts in the rear end caps of the treadmill. (To determine left and right, stand at the rear of the treadmill and face the display).
- Using the appropriate size Allen wrench or socket turn the LEFT adjustment bolt clockwise $\frac{1}{4}$ turn.
- Turn the treadmill on and start the belt at 3mph keeping off the unit.
- Allow 2 minutes for the belt to adjust itself.
- Repeat the above steps if additional adjustment is necessary.

TENSIONING THE RUNNING BELT:

If there is a slipping or jerking sensation when running on the treadmill, the running belt may require tightening. In most cases the belt has stretched from use. Tensioning the belt takes a few simple adjustments. If you are unsure about this procedure, call the TRUE Service Department.

- Locate the belt adjustment bolts in the rear end caps of the treadmill.
- Using the appropriate size Allen wrench or socket turn BOTH adjustment bolts clockwise $\frac{1}{4}$ turn.
- Turn the treadmill on and start the belt and check if the slipping continues. Repeat the above steps if additional adjustment is necessary.

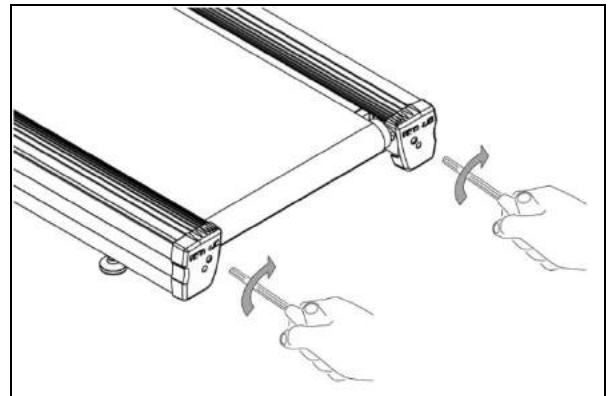

TREADMILL LUBRICATION:

For in-home use over 20 hours per week, TRUE recommends lubricating every three months. For average in-home use of the treadmill, TRUE recommends lubrication under the tread belt once per year.

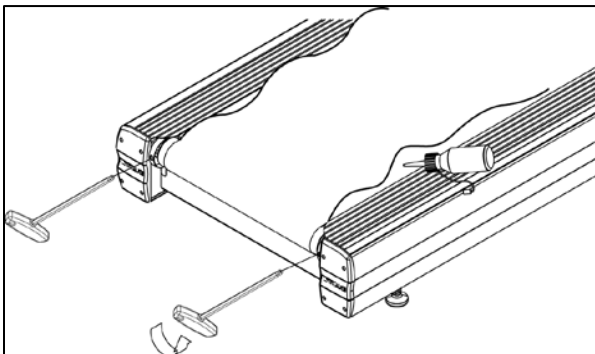

- Loosen the belt adjustment bolts in the rear end caps.
- Lift the belt and apply the lubricant to the center of the deck.
- Center and re-tension the belt using the directions above.
- Walk on the treadmill at 2MPH for about 60 seconds to spread the lubricant evenly through the belt and deck.

*Please contact your dealer or visit www.truefitness.com to obtain the proper lubricants.

CHAPTER 5: CARE & MAINTENANCE

LEVELING THE TREADMILL:

The treadmill has adjustable rear leveling feet. Make sure that the running surface is level. If the treadmill is placed on an uneven surface, adjusting the rear feet can help, but may not completely compensate for extremely uneven surfaces.

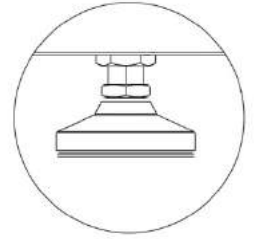

OTHER SCHEDULED PREVENTIVE MAINTENANCE:

TRUE recommends that quarterly scheduled maintenance be performed by a qualified service technician. Please contact your dealer or visit www.truefitness.com to contact a local TRUE authorized service technician.

Scheduled Preventive Maintenance:

- Record time, distance and hours from the console.
- Check error log in console.
- Check running belt and drive belt tension and tracking.
- Remove the motor cover and vacuum any debris out of the drive motor, speed sensor cage, motor control board and heat sink motor compartment.
- Move treadmill and vacuum underneath.
- Lubricate elevation pivot points including rear stabilizing feet and the lift motor screw.
- Lubricate walking belt and deck.
- Inspect all fasteners.
- Inspect all electrical connections.
- Inspect all components for abnormal or premature wear.

▲ CAUTION:

Use only TRUE Fitness certified service providers.

LONG TERM STORAGE:

When the treadmill is not in use for any length of time, turn it off. Make sure that the power cord is unplugged from the power source and is positioned so that it will not become damaged or interfere with people or other equipment.

Storing the Chest Strap:

Store the chest strap in a place where it remains free of dust and dirt such as, in a closet or drawer. Be sure to protect the chest strap from extremes in temperature. Do not store it in a place that may be exposed to temperatures below 32° F (0° C). To clean the chest strap, use a sponge or soft cloth dampened in mild soap and water. Dry the surface thoroughly with a clean towel.

CHAPTER 6: CUSTOMER SERVICE

CONTACTING SERVICE:

TRUE Fitness recommends that you gather the serial number, model number, and a brief description of the reason for the request. After information has been gathered you may choose to contact your selling dealer or local service company to set an appointment. (If you are not familiar with who is in your area, you may visit our website at www.truefitness.com and use our dealer locator to obtain the contact information for the closest dealer).

You may also contact TRUE Fitness' customer support team by calling 800.883.8783 or e-mailing us at service@truefitness.com Monday – Friday during normal business hours.

TRUE FITNESS SERVICE DEPARTMENT

865 HOFF ROAD

ST. LOUIS, MO 63366

1.800.883.8783

HOURS OF OPERATION: 8:30 A.M. - 5:00 P.M. CST

E-MAIL: service@truefitness.com

CONTACTING SALES:

Interested in TRUE Products? Please contact us with any sales or product inquires so that we may direct you to the appropriate sales representative to answer your questions.

TRUE FITNESS HOME OFFICE

865 HOFF ROAD

ST. LOUIS, MO 63366

1.800.426.6570

HOURS OF OPERATION: 8:30 A.M. - 5:00 P.M. CST

E-MAIL: sales@truefitness.com

CHAPTER 6: CUSTOMER SERVICE

REPORTING FREIGHT OR PARTS DAMAGE:

Unfortunately, sometimes materials can be damaged during shipment. If materials are damaged during shipment, please follow the guidelines below to determine the appropriate process for you to follow in case of damages.

Severe Damage:

Obvious damage to external packaging / internal product. Please **refuse** the shipment and it will be returned to TRUE Fitness by the carrier. Contact the TRUE Fitness customer support team by calling 800.883.8783 or sales support team by calling 800.426.6570 Monday-Friday during normal business hours to notify us that the shipment has been refused. Once we have received the damaged shipment, a replacement shipment will be sent to you. Only refuse the damaged piece if the shipment is multiple boxes.

Slight Damage:

The box may have minimal damages and you are not sure if the actual product is damaged or not. You **must** sign the bill of lading as damaged when accepting the shipment. Once you have opened the box and you have determined something is indeed damaged please gather the serial number, model number, description and photos of damages. Please make sure the photos include the damaged product as well as the damaged box the product arrived in. Contact the TRUE Fitness customer support team by calling 800.883.8783 or sales support team by calling 800.426.6570 Monday-Friday during normal business hours.

Concealed Damage:

You may receive a shipment that looks intact and discover once the box has been opened that there are hidden damages. Please notify the carrier **immediately**. We will not be able to file a claim if the carrier is not notified in a timely manner. Once you have called the carrier you will need to gather the serial number, model number, description and photos of damages. Contact the TRUE Fitness customer support team by calling 800.883.8783 or sales support team by calling 800.426.6570 Monday-Friday during normal business hours.

CHAPTER 7: ADDITIONAL INFORMATION

TROUBLESHOOTING GUIDE:

This troubleshooting guide is intended to assist in diagnostics only and is not all inclusive. Technical specifications, error codes and programming are subject to change without notice. TRUE accepts no liability for any damage or loss suffered by persons whom rely wholly or in part on any description or statement contained within this manual. Please visit www.truefitness.com to obtain the most recent version of all manuals and contact the TRUE Service Department at 800-883-8783 for assistance with troubleshooting and diagnostics.

Malfunction	Possible Cause	Corrective Action
No Power	Unit turned off	Verify the On/Off switch is at the ON position
	Damaged power cord	Replace power cord
	Power cord not fully seated in socket	Inspect power connection at the unit and outlet
	No power at outlet	Using a voltmeter verify power at outlet
	Tripped circuit breaker	The location of the circuit breaker is next to the On/Off switch. Verify the circuit breaker is not open. If the breaker is open reset.
Unit resets or pauses randomly	Damaged power cord	Replace power cord
	Power cord not fully seated in socket	Inspect power connection at the unit and outlet
	Safety e-stop key not fully engaged	Re-engage the safety/e-stop key to the console
	Insufficient power	Verify output voltage from 20A outlet with a voltmeter
	Error code is displayed on console	Contact TRUE Fitness Customer Service Department
	Pinched or loose main communication cable	Contact TRUE Fitness Customer Service Department
	No User Present displayed on screen	User weight must be over 90lbs. Verify No User Present settings in console.
Walking belt is off center	Uneven floor	Adjust treadmill with rear leveling feet. See Chapter 5: Running Belt Alignment
	Adjust belt tracking	See Chapter 5: Centering the Running Belt
Walking belt hesitates or slips when stepping	Adjust belt tension	See Chapter 5: Tensioning the Running Belt
	Lubricate running belt	See Chapter 5: Treadmill Lubrication
Rubbing sound from treadmill when in operation	Walking belt is rubbing a straddle cover	Adjust belt tracking. See Chapter 5: Centering the Running Belt
	Foreign object may be stuck under walking belt	Inspect under the unit. Remove and object that may be under the unit.
	Foreign object may be stuck in motor compartment	Contact TRUE Fitness Customer Service Department
	Roller bearings may be damaged	Contact TRUE Fitness Customer Service Department
	Drive motor may be damaged	Contact TRUE Fitness Customer Service Department
	Drive belt may be misaligned	Contact TRUE Fitness Customer Service Department

CHAPTER 7: ADDITIONAL INFORMATION

TROUBLESHOOTING GUIDE (CONTINUED):

Malfunction	Possible Cause	Corrective Action
Heart rate is displaying erratically or not displaying	Transmitter belt contacts are not making good contact with the skin	Re-adjust the transmitter belt so that it is in full contact with the skin
	Contacts on the transmitter belt are not moist	Moisten the contacts on the transmitter belt
	Transmitter belt is not within 3 feet (1 meter) of the heart rate receiver	Adjust your position on the belt so that you are within 3 feet (1 meter) of the console
	The battery inside the transmitter belt is depleted	replace the transmitter belt with a compatible transmitter belt
	Another user wearing a compatible transmitter strap is within 3 foot (1 meter) of the unit	Move the units so that there is more space in-between units
Heart rate is displaying erratically or not displaying (continued)	Environmental interference from high voltage power lines	Move the unit to another position within the room or move the cause of the interference until heart rate reading are stable. If the probable source of interference is plugged into the same outlet move the suspect source to another outlet.
	Environmental interference from computers	
	Environmental interference from motor driven appliances	
	Environmental interference from cell or cordless phone	
	Environmental interference from Wi-Fi router	

Fault Code	Category	Description	Cause	Corrective Action
Fault CN00: Corrupted Console Configuration	Console	Corrupted brainboard configuration - fails integrity check	Corrupt software	Power cycle Re-configure console
			Firmware and software versions are not compatible	Re-install software/firmware Contact dealer or TRUE service
			Console Configure incorrectly	Power cycle Re-configure console
Fault CN01: Internal Fault	Console	Math error - software	Corrupt Software	Re-install software/firmware Contact dealer or TRUE service
			Console Configure incorrectly	Power cycle Re-configure console
			Incline Motor out of range	Contact dealer or TRUE service
Fault CN02: Invalid Console Configuration	Console	The product configuration data has failed validation checks (incline ranges make no sense, etc.)	Loose Cable	Contact dealer or TRUE service
			Console Configure incorrectly	Power cycle Re-configure console
			Incline Motor out of range	Contact dealer or TRUE service

CHAPTER 7: ADDITIONAL INFORMATION

TROUBLESHOOTING GUIDE (CONTINUED):

Fault CN03: Stuck Key	Console	Membrane Key stuck down/closed	Membrane key is damaged	Contact dealer or TRUE service
Fault CN04: Lower Board Comm Fault (Treadmill Only)	Console	Brainboard fails to receive timely communication responses from lower board - Fault after 3 retries	Loose Cable	Power cycle
			Smart Card	Contact dealer or TRUE service
			Motor control board	
			Console	
Fault CN05: No Lower Control	Console	No lower board connected to console - detection wires not connected.	Loose Cable	Power cycle
			Console Configure incorrectly	Check cable connections
Fault CN06: Config Mismatch	Console	Console is configured for a product different than that to which it is connected.	Console Configure incorrectly	Re-configure console
			Loose Cable	Check cable Connections
Fault CN07: Calibration Timeout	Console	Incline Calibration was not able to complete within allowed time.	Low AC Line Voltage	Retry calibration
				Verify AC Voltage at Outlet
Fault CN08: Calibration Failed - Lower Limit Not Reached	Console	During incline calibration, the incline stalled before reaching what should be the lower limit.	Console displays Fault Calibration not saved. Incline disabled.	Power cycle
				Check cable connections
				Run incline calibration
Fault CN09: Insert Safety Key	Console	Emergency Circuit opened	Safety Key not engaged	Contact dealer or TRUE service
			Loose Cable	Re-insert safety key
			Switch Damaged	Check cable Connections
Fault CN10: E-Stop Fault	Console	A test of the emergency circuit has failed	Console Catch	Contact dealer or TRUE service
			Safety Key not engaged	Power cycle
			Loose Cable	Re-insert safety key
			Switch Damaged	Check cable connections

CHAPTER 7: ADDITIONAL INFORMATION

TROUBLESHOOTING GUIDE (CONTINUED):

Fault CN24: BB Comm Fault	Console	SBC cannot communicate with Brainboard	Console	Power cycle
				Contact dealer or TRUE service
Fault CN25: Firmware Mismatch	Console	Firmware on brainboard not compatible with SBC software	Corrupt software	Power cycle
			Firmware and software versions are not compatible	Re-configure console
				Re-install software/firmware
Fault SP01: Belt Under Speed	Speed	Tread motor rpm is below target rpm	High Belt Deck Friction	Lubricate treadbelt
			High belt tension	Contact dealer or TRUE service
				Low Line Voltage
			Dirty or misaligned speed sensor	Contact dealer or TRUE service
Fault SP02: Belt Over Speed	Speed	Tread motor rpm is higher than target rpm	High Belt Deck Friction	Lubricate treadbelt
			Line Voltage	Contact dealer or TRUE service
				Dirty or misaligned speed sensor
Fault SP03: Belt Over Accel	Speed	Tread belt speed increasing too quickly	User is holding belt back	Contact dealer or TRUE service
			High Belt Deck Friction	Do not try to stop belt
				Dirty or misaligned speed sensor
Fault SP04: No Speed Signal	Speed	Speed sensor is not providing speed data	Dirty or misaligned speed sensor	Contact dealer or TRUE service
			High Belt Deck Friction	Lubricate treadbelt
				Low Line Voltage
Fault IN01: Incline Stall	Incline	Incline not moving when commanded	Console displays Fault Calibration not saved. Incline disabled.	Check AC line voltage
			Incline Potentiometer value out of range	Power cycle
				Check cable connections
				Run incline calibration
				Contact dealer or TRUE service

CHAPTER 7: ADDITIONAL INFORMATION

TROUBLESHOOTING GUIDE (CONTINUED):

Fault IN02: Incline Out of Range	Incline	Incline value is out of the calibrated range - does not occur during calibration	Console displays Fault Calibration not saved. Incline disabled.	Power cycle
				Check cable connections
			Incline Potentiometer value out of range	Run incline calibration
Fault IN03: Incline Run Fault	Incline	Incline moving when not commanded	Console displays Fault Calibration not saved. Incline disabled.	Contact dealer or TRUE service
				Power cycle
			Incline Potentiometer value out of range	Check cable connections
				Run incline calibration
Fault IN04: Incline Max/Min	Incline	Incline value is out of expected operating range - may indicate that it is disconnected.	Console displays Fault Calibration not saved. Incline disabled.	Contact dealer or TRUE service
				Power cycle
			Incline Potentiometer value out of range	Check cable Connections
				Run incline calibration
Fault D100: Motor Controller Fault	DC MCB	Motor Control Board Fault	Motor Control Board	Contact dealer or TRUE service
				Power cycle
Fault D101: Lower Board Communication Fault	DC MCB	Endex did not receive communication from BB in 18 seconds	Loose Cable Connection	Contact dealer or TRUE service
				Power cycle
				Motor Control Board upper display/console
Fault D103: Motor Controller Fault	DC MCB	Low Incoming AC Voltage	Low AC Line Voltage	Check AC line voltage
				Power cycle
Fault D104: Motor Controller Fault	DC MCB	Motor Control Board Fault	Motor Control Board	Contact dealer or TRUE service
				Power cycle
Fault D106: Motor Controller Fault	DC MCB	High Incoming AC Voltage	Motor Control Board	Check AC line voltage
				Power cycle
				High Belt Deck Friction
				Lubricate treadbelt
Fault D107: Motor Over Current	DC MCB	High Incoming AC Voltage	High AC line voltage	Check AC line voltage

CHAPTER 7: ADDITIONAL INFORMATION

TROUBLESHOOTING GUIDE (CONTINUED):

Fault D108: Motor Over Current	DC MCB	High Incoming AC Voltage	High AC line voltage	Check AC line voltage
			Motor Control Board	Power cycle
				Contact dealer or TRUE service
High Belt Deck Friction	Lubricate treadbelt			
Fault D109: Motor Controller Zero Current	DC MCB	Low Incoming AC Voltage	Low AC Line Voltage	Power cycle
				Contact dealer or TRUE service
Fault D110: Motor Controller Overcurrent	DC MCB	High Incoming AC Voltage	High AC line voltage	Check AC line voltage
			Motor Control Board	Power cycle
				Contact dealer or TRUE service
High Belt Deck Friction	Lubricate treadbelt			
Fault D111: Motor Controller Voltage Overload	DC MCB	Low Incoming AC Voltage	Low AC Line Voltage	Power cycle
				Check AC line voltage
				Contact dealer or TRUE service
Fault D112: Motor Controller Undervoltage	DC MCB	Low Incoming AC Voltage	Low AC Line Voltage	Power cycle
				Check AC line voltage
				Contact dealer or TRUE service
Fault D113: Motor Controller Control Fault	DC MCB	Incline Stall - incline not moving when commanded	Console displays Fault Calibration not saved. Incline disabled.	Power cycle
				Check cable Connections
				Run incline calibration
			Incline Potentiometer value out of range	Contact dealer or TRUE service
Acme Nut Jammed				
Motor bearings				
Fault D114: Lower Board Incline Range Fault	DC MCB	Incline out of range	Console displays Fault Calibration not saved. Incline disabled.	Power cycle
				Check cable connections
				Run incline calibration
Incline Potentiometer value out of range	Contact dealer or TRUE service			

CHAPTER 7: ADDITIONAL INFORMATION

TRUE RESIDENTIAL



Premium Fitness Equipment Since 1981



The TRUE ES900 treadmill is the answer to premium fitness equipment for your home. The ES900 offers superior durability, performance and innovation. Special touches, like the aluminum straddle covers, make the ES900 stylish enough for any room in your house. The TRUE ES900 is designed to be the best, for those who demand the best. With multiple console options, you can customize the treadmill to meet your family's fitness and wellness needs.



ES900

CHAPTER 7: ADDITIONAL INFORMATION



ES900
TREADMILL

TECHNICAL SPECIFICATIONS	Power Source	110V/15A
	Cord Length	8' (2.4M)
	Drive Motor	4 HP DC Quiet Drive
	Reversible Deck	Standard
	Belt	Orthopedic
	Impact System	True Soft Select (adjustable)
	Frame Construction	Robotically Welded Heavy-Gauge Steel
	Speed Range	0.5 to 12.0 MPH (0.8 to 19.3 km/H)
	Incline/Decline Range	-3% to 15%
	Quick Access Control	Speed and Incline on Hand Grips with Start and Stop on Quick Access Point
	Handrail Design	Extended Handrails with Molded Rubber, Moisture Resistant Grips
	Straddle Cover Design	Aluminum
	Contact Heart Rate Monitoring	Standard
	Wireless Heart Rate Monitoring	Polar® Compatible
AVAILABLE CONSOLES	Transcend®, Transcend ⁹ , Escalate ⁵ , Escalate ⁹	
SAFETY	Safety Clip	Standard
	Extended Handrails	Standard
	Large Straddle Covers	Standard
REGULATORY APPROVALS	ETL UL1647, CSA	
EXTRAS	Accessories	Water Bottle Holder (2), Accessory Tray, Over Molded Reading Rack/Tablet Holder
PHYSICAL SPECIFICATIONS	Footprint	82"L x 33.8"W (208 cm x 86 cm)
	Running Surface	60"L x 22"W (152 cm x 56 cm)
	Machine Weight	430 lbs. (195 kg)
	Maximum User Weight	400 lbs. (181 kg)
	Step-Up Height	9" (23 cm)
	Portability	2 Front Transport Wheels
WARRANTY	Warranty Type	Residential
	Frame	Lifetime
	Motor	Lifetime
	Parts	10 Years (Transcend Consoles are 3 Years) (Escalate ⁵ Consoles are 5 years)
	Labor	2 Years

Warranties outside the U.S. and Canada may vary - Please contact your dealer for details. Specifications subject to change without notice.



iPod is a trademark of Apple Inc., registered in the U.S. and other countries.
Made for iPod means that an electronic accessory has been designed to connect specifically to iPod and has been certified by the developer to meet Apple performance standards. Apple is not responsible for the operation of this device or its compliance with safety and regulatory standards.

BROCH14R10

truefitness.com | 800.426.6570 | 636.272.7100 ©2013 True Fitness Technology, Inc

CHAPTER 7: ADDITIONAL INFORMATION



RESIDENTIAL LIMITED WARRANTY ES900 TREADMILLS

Save time and register online!
Activate Multiple Warranties at truefitness.com.

All TRUE® Fitness products are distributed by TRUE and are warranted to the original registered Product purchaser and the parts of the TRUE product (the “Product”) listed below, under normal use and service, shall be free of manufacturing defects in workmanship and materials only for the period of time beginning from the original date of purchase set forth below:

Frame*	Lifetime
Drive Motor	Lifetime
Parts	
Transcend Touchscreen Escalate ¹⁵ Console	3 Years
Electrical	5 Years
Wear Items	10 Years
Cosmetics	10 Years
	6 Months
Labor	
Parts	2 Years
Motor	2 Years
Cosmetics	6 Months
iPod® Connectivity	
Headphone Jack, Connector & USB Port	90 Days Parts, No Labor

Frame

The frame is warranted for defects in material and workmanship for as long as the original purchaser owns the Product. The frame is warranted for labor and freight (for parts shipped from TRUE) for two years from date of purchase. *This limited warranty on the structural frame does not include paint or coatings.

Drive Motor

The treadmill drive motor is warranted for defects in material and workmanship for the life of the product with a two year labor warranty. This limited warranty does not cover damage or equipment failure resulting from or caused by improper assembly/installation, failure to follow instructions and warnings in owner’s manual, accident, misuse, abuse, unauthorized modification, or failure to provide reasonable and necessary maintenance.

Parts

The treadmill electrical parts and wear items are warranted for defects in material and workmanship for ten years with two years labor warranty. This limited warranty does not cover damage or equipment failure resulting from or caused by improper assembly/installation, failure to follow instructions and warnings in owner’s manual, accident, misuse, abuse, unauthorized modification, or failure to provide reasonable and necessary maintenance. This limited warranty will apply to but may not be limited to the treadmill elevation motor, upper control board, deck, running belt and drive belt. *TRUE Fitness shall not warrant the performance of the heart rate system on its products, as the heart rate system performance varies, based on user’s physiol-

ogy, age, method of use and other factors. *This limited warranty shall not apply to Software version upgrades.

Cosmetics

The treadmill cosmetic parts are warranted for defects in material and workmanship for six months with labor warranty to match the parts warranty period. This limited warranty does not cover damage or equipment failure resulting from or caused by improper assembly/ installation, failure to follow instructions and warnings in owner’s manual, accident, misuse, abuse, unauthorized modification, or failure to provide reasonable and necessary maintenance. This limited warranty will apply to but may not be limited to paint/coatings, covers/ caps, badges, overlays, safety key and straddle covers.

iPod Connectivity: iPod Connectivity elements; headphone jack, connector and USB Port are warranted for defects in material and workmanship for 90 days with no labor warranty.

Labor

Labor is covered for a period of two years from the date of purchase unless otherwise expressed within this limited warranty as long as a TRUE authorized service provider performs the service. Service that requires over 50 miles of travel may be subject to additional charges. Reasonable and necessary maintenance includes proper lubrication of the running deck and tread belt area as specified in the owner’s manual. Failure to maintain proper lubrication of the Product will void this Limited Warranty.

NOTE: Warranty valid for USA and Canada only.

NOTE: Failure to register this product will result in no servicing or authorization of parts to be shipped.

NOTE: Buying after-market products from a 3rd party will result in voided warranty.

NOTE: This product is intended for Residential use. If this product will not be used in this particular setting, please contact TRUE as is warranty is void.

CHAPTER 7: ADDITIONAL INFORMATION



RESIDENTIAL LIMITED WARRANTY ES900 TREADMILLS

Save time and register online!

Activate Multiple Warranties at truefitness.com.

Claims Procedure: TRUE Limited Warranty service may be obtained by contacting the authorized TRUE dealer from whom the Product was purchased. If the dealer from whom the Product was purchased is no longer an authorized TRUE dealer, then TRUE Limited Warranty service may be obtained by contacting TRUE directly at:

TRUE Fitness, Service Department
865 Hoff Road, St. Louis, MO 63366
1-800-883-8783, (Hours of operation 8:30am - 5:00 pm CST)

The above Limited Warranty is subject to and will be in accordance with the conditions set forth below:

1. This Limited Warranty can be processed only if the Warranty Registration Form is completed on-line; or if the attached form is filled in, signed by the original purchaser and mailed to TRUE within 30 days of purchaser's receipt of this Product. The serial number must be intact on the Product for this Limited Warranty to be valid.
2. This Limited Warranty applies to the product only while the Product remains in the possession of the original purchaser and is not transferable.
3. This Limited Warranty becomes VALID ONLY if the Product is initially assembled/installed by a TRUE authorized dealer/technician (if anyone other than a TRUE authorized dealer/technician initially assembles and installs the Product, this Limited Warranty will be void unless the written authorization of TRUE is first obtained).
4. This Limited Warranty does not cover damage or equipment failure resulting from or caused by improper assembly/installation, failure to follow instructions and warnings in owner's manual, accident, misuse, abuse, unauthorized modification, or failure to provide reasonable and necessary maintenance (as referenced in the owner's manual.)
5. This Limited Warranty applies only to the cost of repair or replacement of parts and does not include labor (beyond the above warranty period), transportation, service, return and freight charges associated therewith expressly specified herein.
6. This Limited Warranty shall not apply to: Service calls to correct installation of the equipment or instruction to owners on how to use the equipment; or any labor costs incurred beyond the applicable labor warranty period.
7. This Limited Warranty is in lieu of all warranties, express or implied, and in lieu of all other obligations or liabilities on the part of TRUE, under no circumstances shall TRUE be liable by virtue of this Limited Warranty or otherwise from damage to any person or property whatsoever for any special, indirect, incidental, secondary or consequential losses, damages or expenses in connection with exercise products.

Any implied warranty is limited in duration to the time period covered by the Limited Warranty. Some states do not allow limitations on how long an implied warranty lasts, or the exclusion may not apply to you. This Limited Warranty grants you specific legal rights and you may also have other rights, which vary from state to state.

NOTE TO AUTHORIZED WARRANTY LABOR PROVIDERS:

Warranty labor reimbursement or warranty parts rights may not be transferred to, reassigned to, a third party without the express written consent of TRUE. Even jobbing out warranty labor requires TRUE's written approval.

truefitness.com / 800.426.6570 / 1.636.272.7100

PLEASE RETAIN THIS PORTION FOR YOUR RECORDS

SERIAL NUMBERS:

Your TRUE treadmill comes with two serial numbers; one on the base and one on the display console (see diagram below). The serial number on the base is on the lower portion of the treadmill directly adjacent to the power inlet. The console serial number is located on the bottom right side of each console. Please write down your serial numbers below and keep for your records.

Write in Your Serial Number Here:

CONSOLE SERIAL NUMBER:

BASE SERIAL NUMBER:



 TRUE FITNESS TECHNOLOGY, INC. ST. LOUIS, MISSOURI 63366	Model No. TES900-4
 Intertek 3135202	Serial No./Date Code 13-TES900001A
CONFORMS TO ANSI/UL STD. 1647 CERTIFIED TO CAN/CSA STD. C22.2 NO.68	Rating: 120V, 50/60 Hz, 15A
Intertek Testing Services Taiwan Ltd.	MADE IN TAIWAN

CHAPTER 7: ADDITIONAL INFORMATION



RESIDENTIAL LIMITED WARRANTY ES900 TREADMILLS

Thank you for purchasing a TRUE product. To validate the TRUE product warranty the fast and easy way, please go on-line now to www.truefitness.com and register your product. The information you provide will never be distributed to any other individuals or agencies for any purpose. If you prefer to mail your warranty card, have the owner of the product complete the information below and return it to TRUE Fitness within 30 days from the date of equipment installation.

To mail your warranty information, please fill in the information below and mail to: Service Dept., TRUE Fitness, 865 Hoff Road, St. Louis, MO 63366 (or save postage and register online at www.truefitness.com)

Residential Warranty Registration

Model Type: Treadmill Elliptical Bike

Other _____

Date of Purchase _____

Purchased From (dealer name) _____

First Name _____

Last Name _____

Address _____

City _____ State _____ ZIP _____

Email Address _____

Phone _____

1. Where did you first learn about TRUE?
 a. Dealer b. Website
 c. Referral d. Gym/Club
 e. Current Customer f. Other _____

2. The primary user(s) is:
 a. Male b. Female
 c. Both

3. Do you currently belong to a health club?
 a. Yes b. No

4. Your age group:
 a. Under 25 b. 25-35
 c. 36-45 d. 46-55
 e. 56-65 f. 65+

5. What was the primary reason you bought a TRUE product? (Check only one)
 a. Design/Appearance b. Dealer
 c. Price d. Ease of Operation
 e. Quality of Construction f. Size
 g. Reputation h. Warranty
 i. Friend/Family Recommendation

6. Do you plan to purchase more fitness equipment in the next 6-12 months?
 Yes No

7. If you answered "yes" to question 6, what type do you plan to purchase?
 a. Treadmill b. Elliptical
 c. Stationary Bike d. Free Weights
 e. Gym c. Other _____

8. What is your annual household income? (Optional)
 a. Under \$50,000
 b. \$50,000 - \$75,000
 c. \$75,000 - \$100,000
 d. \$100,000 - \$150,000
 e. \$150,000+

9. You are a valued customer of TRUE and your suggestions allow us to continually improve your experience. Is there anything else you would like us to know? Please explain:

**PLEASE PROVIDE BOTH SERIAL NUMBERS BELOW.
REQUIRED FOR WARRANTY REGISTRATION:**

CONSOLE SERIAL NUMBER:

BASE SERIAL NUMBER: