



TRIPOLLAR®
INTELLIGENT
BIOLOGY™

STOP®

FACIAL

RENEWAL AND REJUVENATION

USER MANUAL

ENGLISH

ENGLISH

Congratulations on purchasing your TriPollar® STOP® device!

You have taken the first step toward flawless beautiful skin!
This user manual describes the TriPollar STOP product and how to use it.

TABLE OF CONTENTS

INTRODUCING TRIPOLLAR STOP	8
• OVERVIEW	
• THE TRIPOLLAR STOP KIT	
USING TRIPOLLAR STOP	11
• THE TRIPOLLAR STOP DEVICE	
• BEFORE YOU BEGIN	
• TREATING YOUR SKIN	
• RECOMMENDED TREATMENT GUIDELINES	
TROUBLESHOOTING	20
CUSTOMER SUPPORT	20
TECHNICAL SPECIFICATIONS	21
APPENDIX	22

IMPORTANT NOTICE

© Pollogen Ltd. All rights reserved.

Design and technical specifications are subject to change without prior notice. Manufactured by Pollogen Ltd.

Patented technology.

The names Pollogen, TriPollar and STOP are registered trademarks of Pollogen Ltd.

All intellectual property rights in this publication are owned by Pollogen Ltd. and protected by applicable copyright laws and international treaty provisions. Pollogen Ltd. retains all rights not expressly granted. No part of this publication may be reproduced in any form whatsoever or used to make any derivative work without prior written approval by Pollogen Ltd.

All other trademarks are the property of their respective owners. Other company and brand products and service names are trademarks or registered trademarks of their respective holders.

SAFETY

Important: Be sure to read the entire user manual prior to use of the product. Always adhere to all warnings and cautions. Be sure to follow all safety precautions below when using the TriPollar STOP product.

To learn more about TriPollar technology, visit our website at: www.stop-age.com

① WARNINGS AND CAUTIONS

TriPollar STOP is an electrical device that must be used properly. To reduce the risk of injury from electric shock, adhere to all warnings and cautions below:

- Do not touch the device should it fall into water. Unplug the device immediately with dry hands.
- Do not place or store the device near any source of water, such as a sink or bathtub.
- Do not submerge the device under water.
- When plugged in, do not leave the device unattended.
- Before use, ensure that the system and its power supply do not show any visible damage. Do not operate if the electric cord is damaged or if the system is disassembled.
- Only use the device with the electric cord and power supply provided.
- Keep the device out of the reach of children.
- Be sure that your hands are completely dry when operating the device.
- Turn the device OFF and then unplug the power supply from the electrical outlet after use or before cleaning and maintenance.

- Use STOP Preparation Gel during treatment according to its instructions for use.

SAFETY INSTRUCTIONS

- Only use this device for its intended purpose, as described in this manual.
- Do not use the device over eyelids, closed eyes, thyroid area, lips, ears, breasts or genital areas.
- The sensation while using the device should be warm and pleasant. If you experience discomfort, discontinue use immediately.

Failure to follow the instructions in this manual may cause damage or burns to your skin.

DO NOT USE THE DEVICE IF ANY OF THE FOLLOWING APPLY TO YOU:

- Are under 18 years of age.
- Have a pacemaker or internal defibrillator.
- Have metal implants in the treatment area, such as gold threads. This does not apply to dental fillings or implants, which present no problem.
- Currently have cancer or a history of cancer, especially skin cancer or premalignant moles.
- Have severe concurrent conditions, such as cardiac disorders.
- Are pregnant or nursing.
- Have an impaired immune system due to immunosuppressive diseases such as AIDS, or are using immunosuppressive medications.
- Have any disease that is stimulated by heat, such as recurrent Herpes Simplex (within the treatment area).

- Have any active skin condition within the treatment area, such as sores, psoriasis, eczema or a rash.
- Have a history of keloid scarring, abnormal wound healing or fragile skin.
- Have had any surgical procedure, laser resurfacing or deep chemical peeling within the treatment area within the past three months or are still undergoing a process to complete healing.
- Have permanent fillers within the treatment area.
If you have temporary dermal fillers within the treatment area, consult your physician before using the device.
- Have had Botox administered in the treatment area within the past three months.
- Have suspicious lesions within the treatment area.
- Currently use medications, herbal preparations, vitamins or food supplements that may cause fragile or dry skin.

POSSIBLE SIDE EFFECTS

The following side effects are rare. However, should they occur, they are usually temporary. If any of the following conditions appear and last more than 24 hours, consult your physician:

- Pain
- Damage to natural skin texture (crusting, blistering, burns, fragile skin, bruising)
- Mild headache

For other aesthetic procedures or should you have any uncertainty regarding potential side effects, consult your physician before using the device.

INTRODUCING TRIPOLLAR STOP

This chapter introduces the TriPollar STOP product and describes its components.

OVERVIEW

TriPollar STOP is a safe, effective and easy-to-use skin renewal device that delivers professional level aesthetic results in the comfort of your own home. The TriPollar STOP device produces genuine, noticeable, immediate and long-lasting results. Powered by Pollogen's revolutionary, patented TriPollar technology, TriPollar STOP delivers RF energy into the dermis skin layer. TriPollar energy stimulates dermal activity to increase and accelerate the natural production of collagen, the protein responsible for the skin's supple texture. Increased collagen levels in the skin result in tighter, more-supple skin. When the TriPollar STOP device is used properly in accordance with the recommended treatment protocol, it effectively postpones the signs of aging.

THE TRIPOLLAR STOP KIT

The TriPollar STOP kit contains the following components:

1. TRIPOLLAR STOP KIT (FIG.1)



FIG.1

2. TRIPOLLAR STOP DEVICE (FIG.2)
3. TRIPOLLAR STOP POWER SUPPLY AND ELECTRIC CORD (FIG.3)
4. TRIPOLLAR STOP ELECTRICAL OUTLET ADAPTERS (FIG.4)
5. STOP PREPARATION GEL (FIG.5)

After the container has been opened, the gel can be used for up to 12 months.

Important: It is recommended to perform a patch test 24 hours prior to initial use. See page 13 for details.

6. TRIPOLLAR STOP USER MANUAL (FIG.6)
7. TRIPOLLAR STOP WARRANTY POLICY (FIG.6)

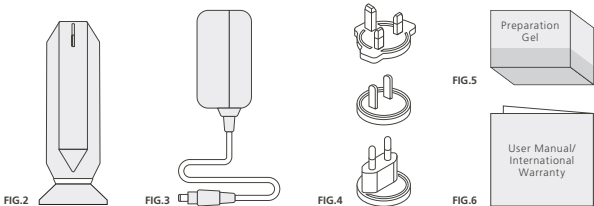

USING TRIPOLLAR STOP

This chapter describes the TriPollar STOP device and how to use it.

THE TRIPOLLAR STOP DEVICE

The TriPollar STOP device is used to increase and accelerate collagen production in your skin for rejuvenation and anti-aging effect.

TriPollar STOP focuses heat deep within the dermis of your skin, as shown below.

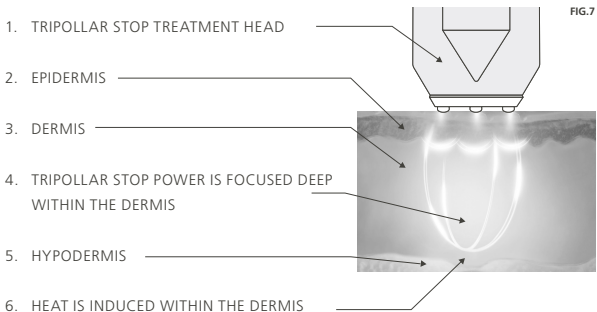
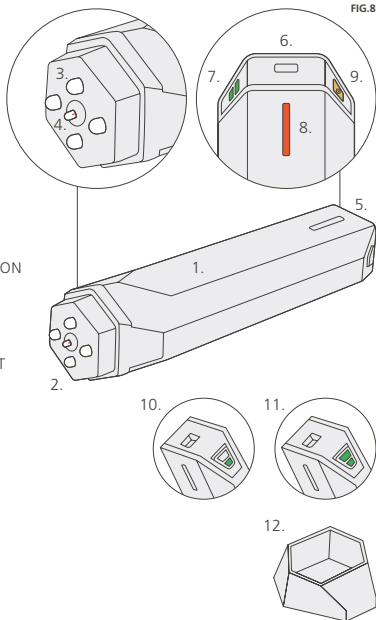

Fig.8 shows the components comprising the TriPollar STOP device.

1. DEVICE BODY
2. TREATMENT HEAD
3. ELECTRODE
4. TEMPERATURE SENSOR
5. CONTROL PANEL
6. POWER SUPPLY CONNECTION
7. GREEN INDICATOR LIGHT
8. ORANGE INDICATOR LIGHT
9. ON/OFF BUTTON
10. LOW RF
11. HIGH RF
12. PROTECTIVE COVER



BEFORE YOU BEGIN

Before using the TriPollar STOP device, do the following.

1. Open the box containing the device, and remove the device and its power supply.
2. Insert the adapter onto the electrical posts (Fig.9)
3. Twist the adapter clockwise to secure it (Fig.10)
4. Connect the power supply to the device (Fig.11)
5. Plug the power supply into an electrical outlet (Fig.12)
6. Remove the STOP Preparation Gel from its box.

Important: Before using the device for the first time, it is recommended to perform a patch test 24 hours prior to initial use. To do so, apply a small amount of STOP Preparation Gel to the inner arm and treat the area with the TriPollar STOP device. Ensure that the skin does not have a negative reaction to the gel or treatment.

7. Remove the protective cover from the device (Fig.8).

You are now ready to treat your skin using TriPollar STOP, as described on page 14.

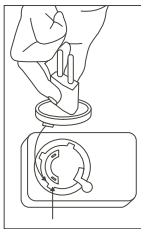

FIG.9

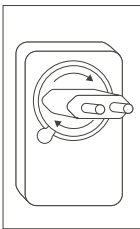

FIG.10

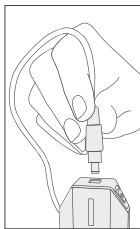

FIG.11

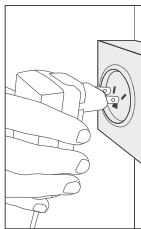

FIG.12

TREATING YOUR SKIN

To treat your skin using the TriPollar STOP device:

1. Cleanse and dry the treatment area.
2. Apply a very thin, even layer of STOP Preparation Gel over the entire treatment area (face and/or neck). This gel must be used during the entire treatment session. Your skin may feel a warm sensation when the gel is applied.
3. Turn the device ON by pressing the Power button (Fig.13). Make sure that the green indicator light turns ON (Fig.8).

Tip: A long press of the Power button turns the device OFF.

4. Select the power setting (Low/High) that is most comfortable for you. When the green indicator light shows a single green light illuminated (Fig.14), the device is operating at the Low power level. You can press the Power button again to change to the High power level (Fig.15).

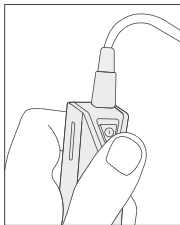

FIG.13

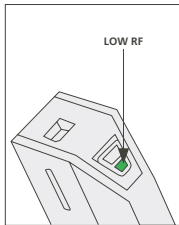

FIG.14

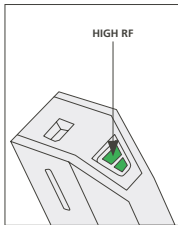

FIG.15

Important: During your first treatment session, we recommend that you use the Low power setting and then adjust the power level according to your skin's tolerance for subsequent treatments.

5. Divide the entire treatment area into two main sections – one for each side of your face and/or neck (right side and left side). Typically, you treat one side of your face/neck entirely before treating the other side. Divide each side into several working sections that are approximately twice the size of the device head. In general, you first treat one working section and then move to an adjacent section. You repeat this general technique and movement until you have treated one entire side of your face/neck. Then, you use the same technique to treat the other side of your face and neck (Fig.16).
6. Place the device on your skin, ensuring that all four electrodes are touching the skin. For best results, all four electrodes must be in full contact with the skin at all times during treatment.

7. Start moving the device in very slow circular motions or small figure eights, slowly heating your skin (Fig.17). The orange indicator light will turn ON (Fig.8) when the skin is heated to the optimal temperature. In addition, a beep will sound to indicate that the optimal treatment temperature has been reached.

Important: Be sure to keep the device constantly moving on your skin. Do not leave the device on one place for long without movement, as skin overheating may occur. Be sure to constantly move the device slowly over the skin to ensure proper heating of the treated area. Moving the device too fast will not achieve the intended effect.

8. Once the orange light turns ON and a beep sounds, continue moving the device within one working section using the same slow circular motions for a few moments and then, move to an adjacent working section. The new working section now includes the heated section and the new section, thus enlarging the area. You may want to start your treatment by treating the section at the jaw line, and then moving to the nasal area and so on, moving from the bottom to the top of your face (Fig.18).

The device's automatic temperature-optimization mechanism protects the skin from overheating. After the skin has reached the maximal treatment temperature, the green indicator light goes OFF and the orange indicator light goes ON to indicate that the energy source has been automatically

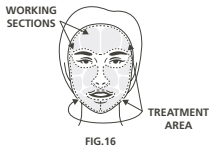

shut down. The device automatically turns itself back ON when the skin temperature drops below the optimal temperature or when you move the device to an adjacent treatment area where the skin temperature is lower. As you move from one section to another, the orange indicator light turns OFF if the temperature of the skin in an area is not warm enough. This is normal. Therefore, as you work within one working section and move back to the previous section, you maintain the heat in that area too. In this way, as you move back and forth between working sections, you are able to maintain the heat in both sections for as long as possible. For effective treatment, the goal is to maintain the optimal temperature for several seconds before moving to the next treatment section. This means that the orange indicator light should be illuminated as much as possible when treating an area.

Important: The orange indicator light turns ON and OFF, depending on the temperature of the skin in the current area of treatment. The orange light is ON when the temperature of the skin in that area is sufficiently heated and is OFF when it is not. In addition, a beep sounds whenever the orange indicator light turns ON.

For optimal treatment, it is recommended to begin the treatment using the Low power setting and to follow the guidelines below:

- If the orange indicator light and sound indicators do not appear within five minutes, or if you do not feel any heating, try moving the device as slowly as possible without stopping the motion. Slow, circular, constant movements are more effective than rapid movements. The slower the movement, the faster the treatment area heats internally.
- If the orange indicator light and sound indicators turn ON immediately or if you feel excessive heat, select a lower power level.

- If the orange indicator light and sound indicators do not appear after 3–5 minutes, select a higher power level. If the indicators still do not appear after increasing to the High power setting, try moving the device more slowly, without stopping the motion.
9. Repeat this technique one working section at a time until the entire treatment area has been heated.
 10. For best results, after treating all working sections on one side of your face/neck, go over the entire treatment area in large sweeping circles for few minutes to rewarm the entire area, without waiting for the orange indicator light to illuminate. This action maintains the optimal temperature and achieves heat uniformly across the entire treatment area. This completes the treatment session for one side of your face and neck.
 11. Repeat steps 4–10 for the other side of your face and neck. After the entire treatment area has been rewarmed, the treatment session is complete. As a natural result of the treatment, the skin may show some redness (erythema) and minor skin swelling (edema) in the treatment area. Both should disappear after a short time.
 12. Press the Power button for two seconds to turn the device OFF.
 13. Unplug the power supply from the electrical outlet.
 14. Gently remove the STOP Preparation Gel from your skin and wash your face. You can apply a moisturizer if you like.
 15. Clean the electrodes of the device with a damp cloth or paper towel and cover the device tip with its protective cover.

Warning: Do not submerge the TriPollar STOP device under water.

RECOMMENDED TREATMENT GUIDELINES

The following treatment guidelines are recommended for using the TriPollar STOP device:

- Treating the entire face takes approximately 20 minutes. For shorter treatment times, focus on selected areas of concern. Treatment times differ for each person.
- For optimal results, use the TriPollar STOP device 2–3 times a week for a period of 6–8 weeks.
- Make sure that you allow at least one day in between treatments on the same treatment area.
- To maintain long-term results after finishing the full course of treatments, we recommend that you use your TriPollar STOP device 2–4 times a month or as needed.

TROUBLESHOOTING

This chapter describes how to troubleshoot problems that may arise when using the TriPollar STOP device.

If your TriPollar STOP device is not working, take the following steps before contacting the service center:

- Ensure that you have removed the device's protective cover.
- Make sure that the electric cord is securely connected to the device and the Power supply adapter is firmly connected.
- Press the Power button and verify that the green indicator light illuminates.
- Ensure that you applied the STOP Preparation Gel according to instructions described in this manual. The TriPollar STOP device does not work properly when the preparation gel is not applied.

CUSTOMER SUPPORT

This chapter provides customer support contact information for the TriPollar STOP device.

For service, refer to the store where you purchased the TriPollar STOP device or visit our website at **www.stop-age.com**. When contacting a local service center, have the device serial number ready. The serial number is located on the top panel of the device. Customer satisfaction is our top priority. To help us provide you with the best support possible, please send us your comments and suggestions. Contact information is provided on the back cover of this manual, or you can contact us via our website (see above).

TECHNICAL SPECIFICATIONS

This chapter presents the specifications for the TriPollar STOP system.

TABLE 1

Technical Specifications

Weight:	85 gm
Physical Dimensions:	H=134mm L=51mm W=32mm
TriPollar RF Frequency:	1MHz

TABLE 2

Operating conditions

Temperature:	+5°C to +30°C
Humidity:	20RH to 80RH
Rating:	AC 100Vac to 240Vac 0.6 A 50/60Hz DC 8V 1.5A

TABLE 3

Transport and Storage

Temperature:	0°C to 40°C
Humidity:	10RH to 90RH

TABLE 4

Electrical Safety

Power supply is classified as Class II double insulation

HAZARDOUS MATERIALS DECLARATION

This appendix provides the hazardous materials declaration for the TriPollar STOP device.

Restriction of Hazardous Substance Material Declaration

TABLE 5 - IS IN ACCORDANCE WITH THE PROVISIONS OF SJ/T 11364

Part Name	Hazardous Substances					
	PB	HG	CD	CR ⁶⁺	PBB	PBDE
DIODE	X	•	•	•	•	•
MOSFET	X	•	•	•	•	•
UK AC PIN	X	•	•	•	•	•
EU AC PIN	X	•	•	•	•	•
OTHER	•	•	•	•	•	•

- x Indicates that the named hazardous substance contained in at least one of the homogeneous materials used for this component may be above the limit requirement of GB/T 26572. The restricted materials are used in accordance with manufacturing needs. Use of such materials has no impact on the device's safety and no harmful effect on device users. **This declaration is included to remind device users that the device must be disposed of reasonably and in accordance with the environmental policy of your locale.**
- Indicates that the named hazardous substance contained in all of the homogeneous materials for this component is below the limit requirement of GB/T 26572.

STOP®

 POLLOGEN LTD.

6 KAUFMAN ST.

GIBOR HOUSE P.O.BOX 50320

TEL AVIV, ISRAEL 6801298

TEL: +972(0)3 5104110

FAX: +972(0)3 5174112

EMAIL: INFO@POLLOGEN.COM

 OBELIS S.A.

53 BLVD. GÉNÉRAL WAHIS

B-1030 BRUSSELS, BELGIUM

TEL: +32(0)2 7325954

FAX: +32(0)2 7326003

EMAIL: MAIL@OBELIS.NET

© POLLOGEN LTD., ALL RIGHTS RESERVED. 14700101EUK / REV 2

DESIGN AND TECHNICAL SPECIFICATION ARE SUBJECT TO CHANGE WITHOUT PRIOR NOTICE.

MANUFACTURED AND DISTRIBUTED BY POLLOGEN LTD.

PATENTED ISRAELI TECHNOLOGY, MADE IN CHINA.

THE NAME STOP IS TRADEMARK OF POLLOGEN LTD.

THE NAMES POLLOGEN AND TRIPOLLAR ARE REGISTERED TRADEMARKS OF POLLOGEN LTD.

FOR MORE INFORMATION, PLEASE VISIT: WWW.STOP-AGE.COM

