

## Sheds and Garages

# V9 ROLLER DOOR LOCK

### APPLICATION

- Garage roller doors

### FEATURES & SPECIFICATIONS

- Minimum protrusion from garage door surface, barrel sits in install cut-out (no fascia required)
- Retractable locking arms feature mounting holes for locking rods
- Locking arms operable by key externally (19mm throw)
- Key removable in horizontal position only (to allow for internal override)
- Internal override options available: key or latch
- Zinc diecast lock and fascia, steel locking arms

### CODE INFORMATION

#### Key Series

Double Entry, 400 combinations, non-master	23
Double-ended entry, 100 combinations, for internal key override	25
Double Entry, 1000 combinations, non-master	CL

#### Movement

180° rotation to unlock	H
90° clockwise rotation to unlock	C

#### Internal Override

Latch, manual grip override	L
Key, double-ended entry barrel	K

#### Arms

Standard, 259mm extended arm span	-
Extended, 336mm extended arm span	E

#### Latch Options

Plastic Turn Grip, black	A
Static, for internal key override	C
Metal Latch, zinc colour	G

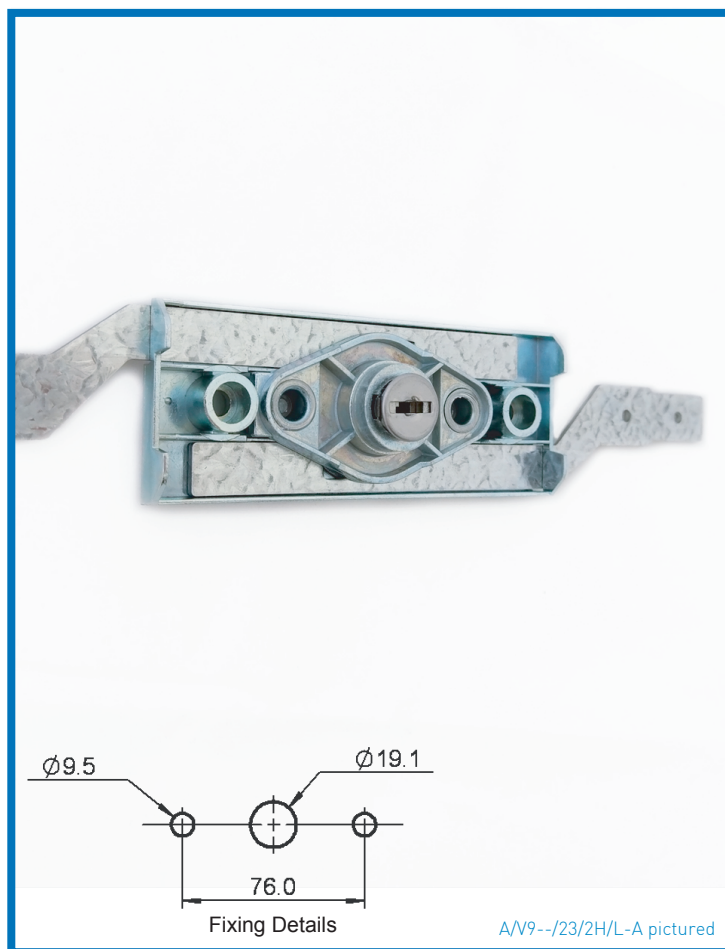

A/V9--/23/2H/L-A pictured

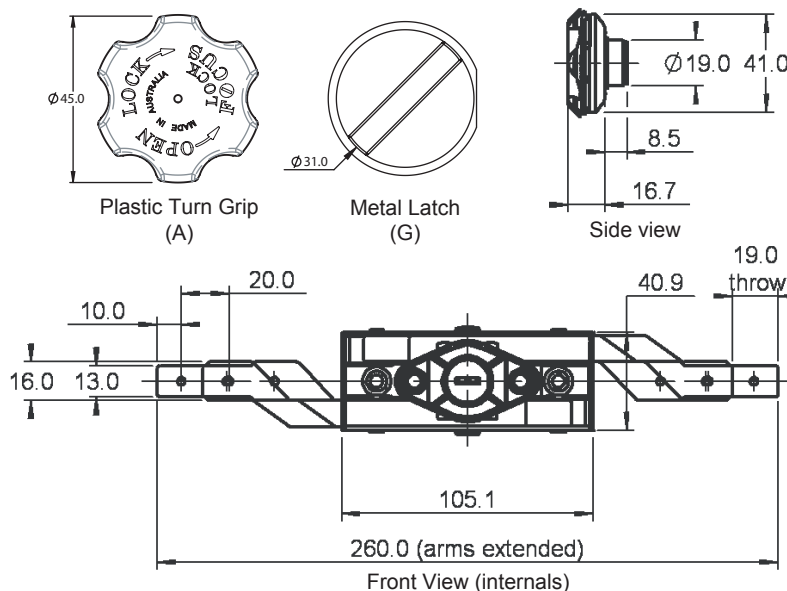

### ORDERING DETAILS

A/V9--/key series/2+movement/internal override+arm+latch    Ordering example: A/V9--/23/2H/L-A