

SPORTS LIGHTING STRUCTURES

POLES + BRACKETS



WILLTM

WISCONSIN
LIGHTING
LAB

LIGHTING SOLUTIONS FOR ANY FIELD.



HELIOS
O L Y M P I A



HERITAGE
** LED Sports Lighting **

Trusted LED Luminaires

Our LED sports lights use only premium components including CREE LED chips for the longest LED life span available! We offer 2 levels of fixtures based off IES criteria for playing fields. For higher end Class 1 or 2 fields like professional or college stadiums the Helios sports lighter is the ideal fixture. For Class 2 to 4 fields the Heritage sports lighter provides the look of a traditional housing design with the power and efficiency of LED.

- » Complete your sports lighting assembly with Helios or Heritage LED Sports Lighting!
- » Manufactured in Wisconsin, USA.
- » Traditional and modern design options for a variety of fields & budgets.



HD Galvanized Coat

Hot-dipped galvanized finish to protect your investment from the elements. Other finishes available including paint or paint over galvanized. Contact factory for color options and details.

Base Mounting Options

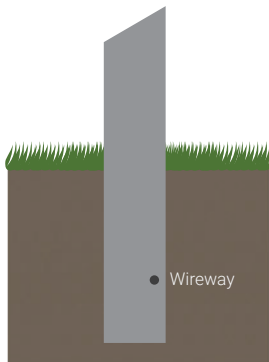

Direct Burial

- » Easier Installation
- » Most economical option

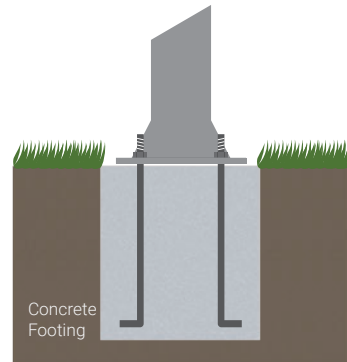

Anchor Base

- » More rigid anchorage method
- » Anchor bolts can preship to prep installation before poles ship

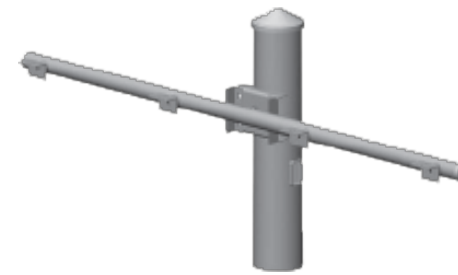

Tubular Crossarm

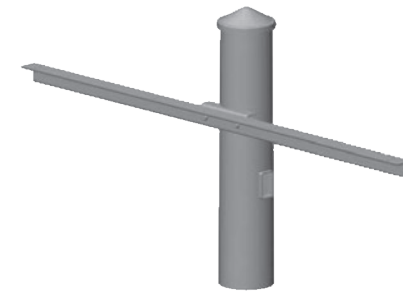

Angle Iron Crossarm



Caged Platform & Arms

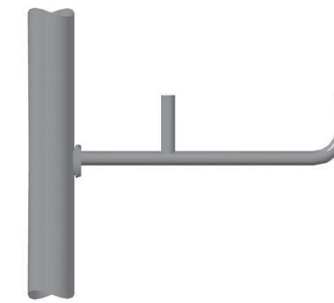

Bullhorn Brackets

Luminaire Mounting Brackets

Whether you need 2 lights or 24 lights for your field we have the mounting brackets to accommodate your application. Crossarm styles are perfect for smaller fields and lower quantity fixtures. Bullhorns provide the most versatility for light fixture aiming and caged platforms are designed for large stadiums and fields.

Durable Steel Shaft

Each pole is a constant tapered hollow steel section and is up to 55' in length with a 1 1/2 times diameter slip joint as standard. The pole shaft sections are high strength steel to ASTM A572, ASTM A595, or weathering steel to ASTM A871 or ASTM A595 GR.C. All Sports Poles are designed to AASHTO 2009-13, Fatigue Category 1 standards.



SELECT YOUR CONFIGURATION



Design Data

_____ Design Criteria*

_____ Design Wind Speed (Specify Ultimate or Nominal)

Fixture Mounting Data Cage or Crossarm Type

_____ ft. (Cages = Middle Row of Lights; Crossarms = Top Row)

_____ Fixture Make & Model

_____ Fixture Weight

_____ Fixture E.P.A.

_____ Total Number of Fixtures

_____ Number of Fixtures Per Row (Total Forward & Backward Facing)

*All designs will be checked to AASHTO 2009-1 3, Fatigue Category 1.

Pole Top

- Cages
- Tubular Crossarms
- Angle Iron Crossarms
- Bullhorns

Base Style

- Anchor Base
- Embedded - Depth (if known): _____

Finish

- Galvanized
 - Finished Paint
 - Finished Paint over Galvanized
- Color: _____

Accessories

- Step & Safety Cable
(not recommended for crossarm applications)
- Personal Safety Harness
- Pre-Wiring of Cages/Tubular Crossarms
- Speaker Mounting Plates
(Please specify requirements)
- Additional Flood Lighting Mounting
(Please specify requirements)
- Couplings
Size & Location (if known): _____
- Other _____

CAGED PLATFORM & ARM DETAIL

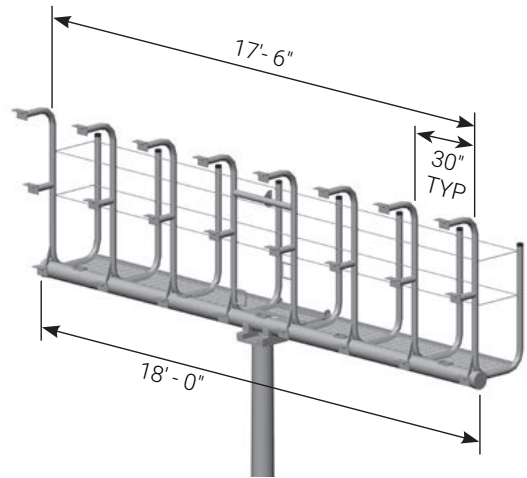

X24 CAGE
(24 Luminaires)

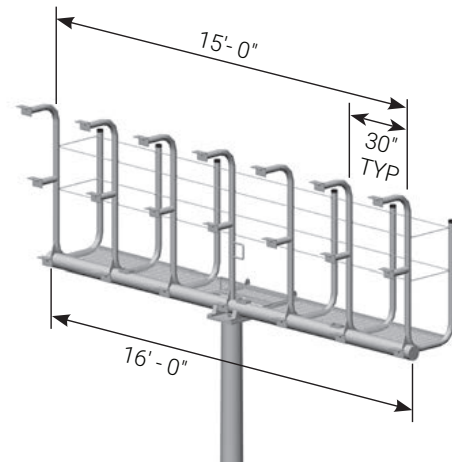

Y21 CAGE
(21 Luminaires)

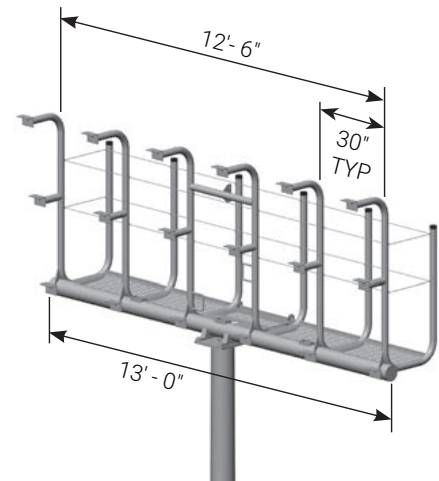

A18 CAGE
(18 Luminaires)

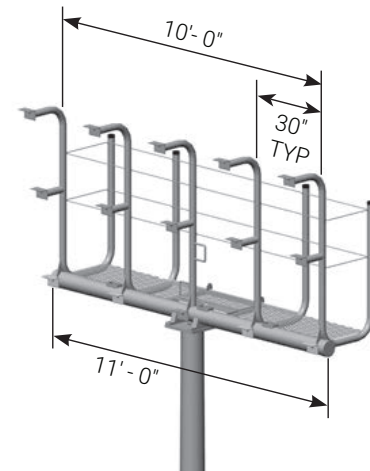

T15 CAGE
(15 Luminaires)

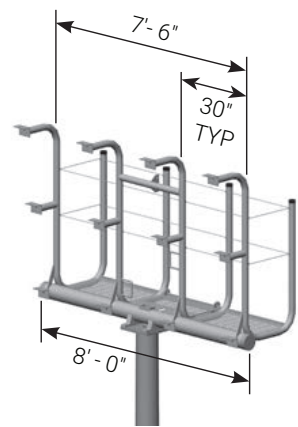

B12 CAGE
(12 Luminaires)

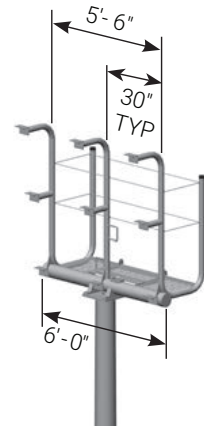

W9 CAGE
(9 Luminaires)

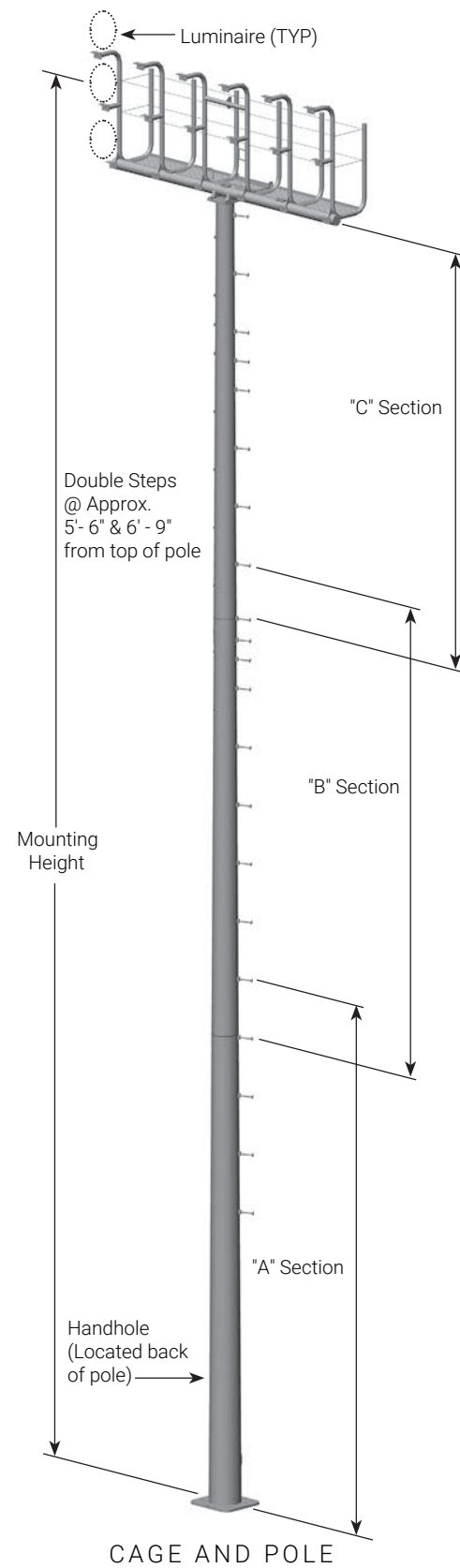

CAGE AND POLE

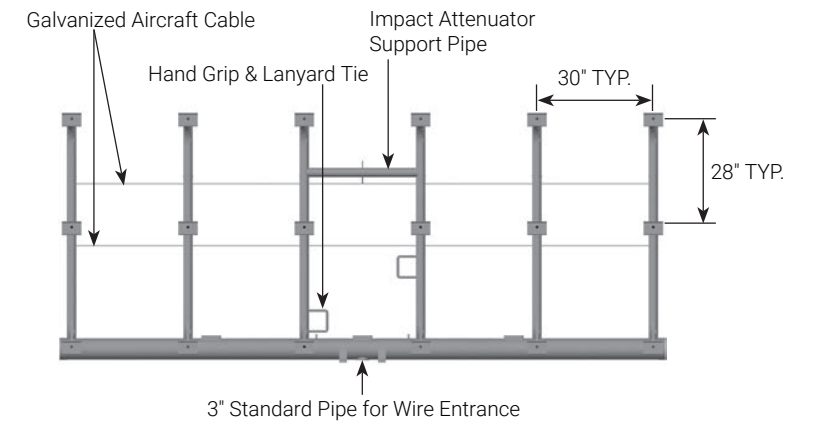

FRONT VIEW

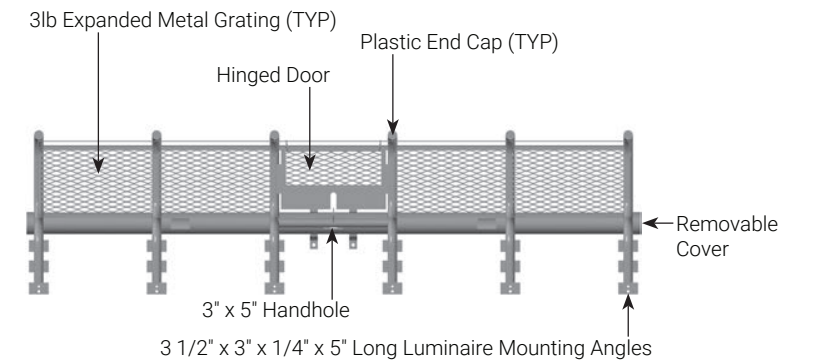

TOP VIEW

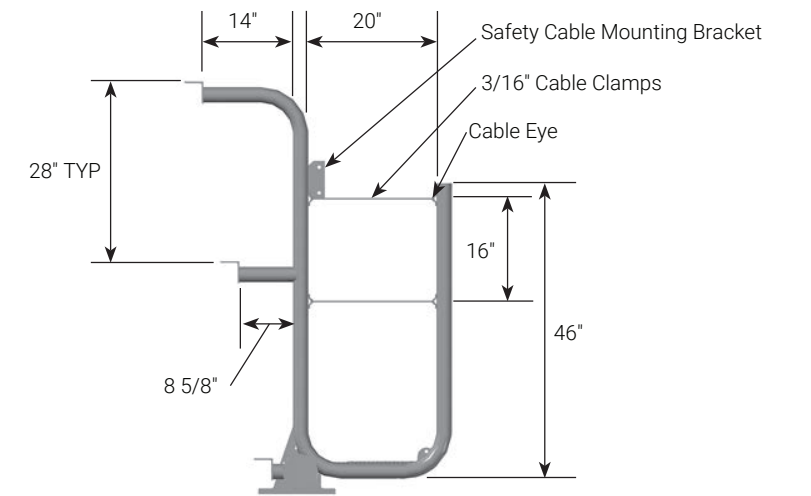

SIDE VIEW

TUBULAR CROSS ARM DETAIL

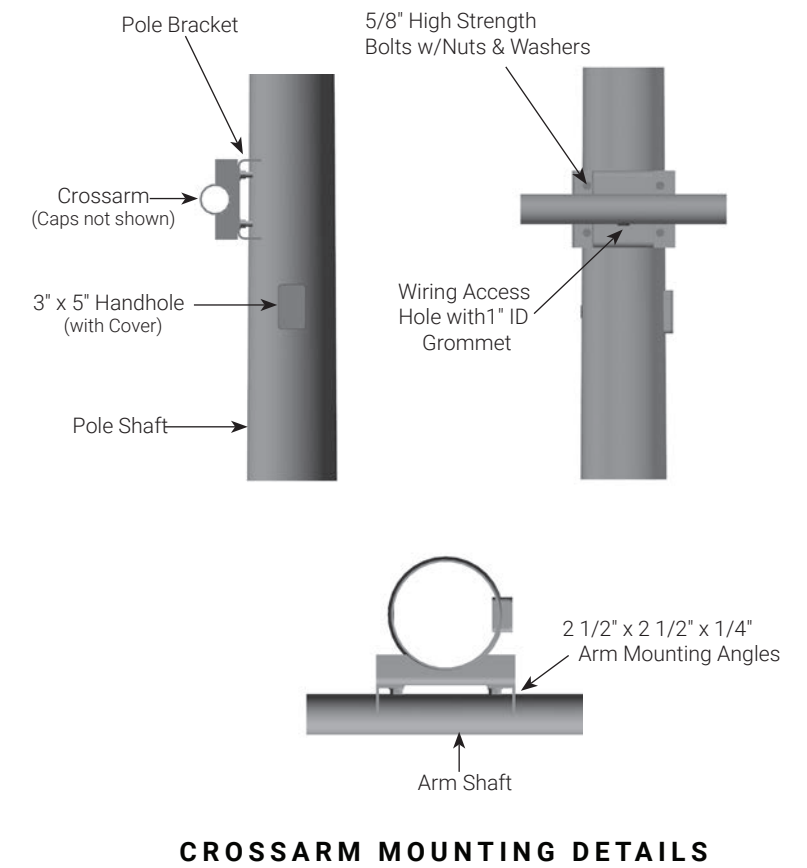
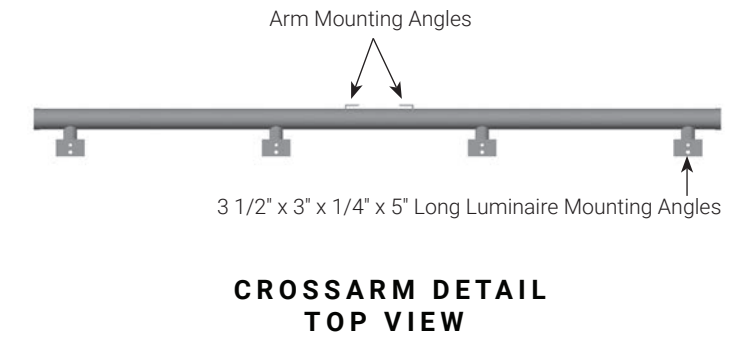
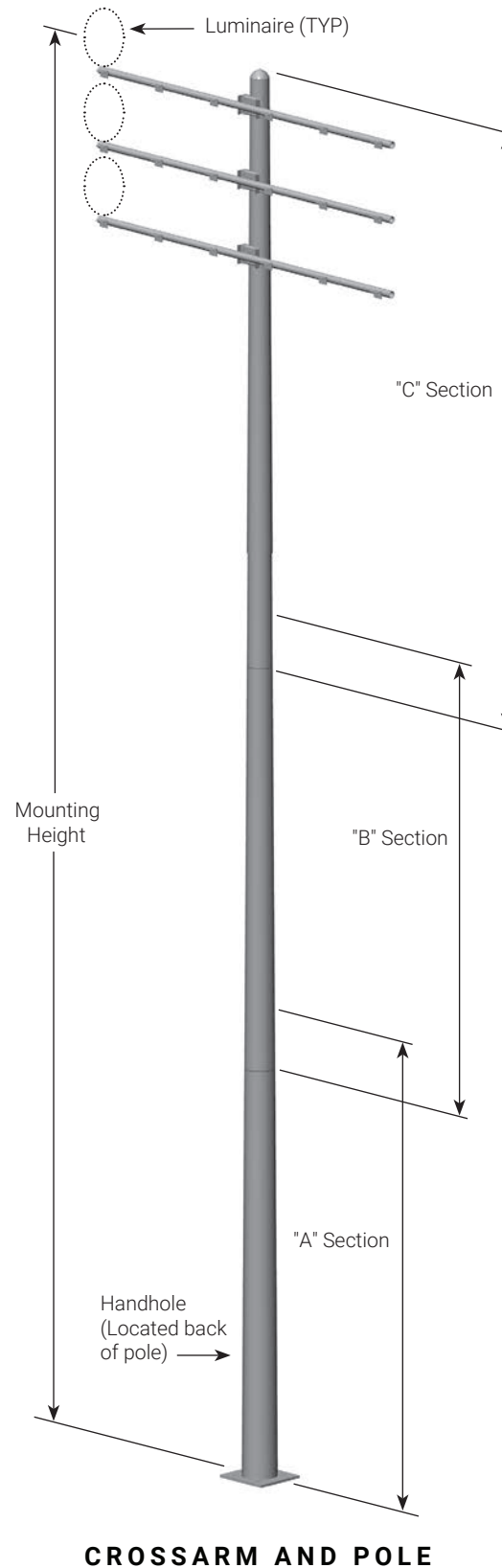
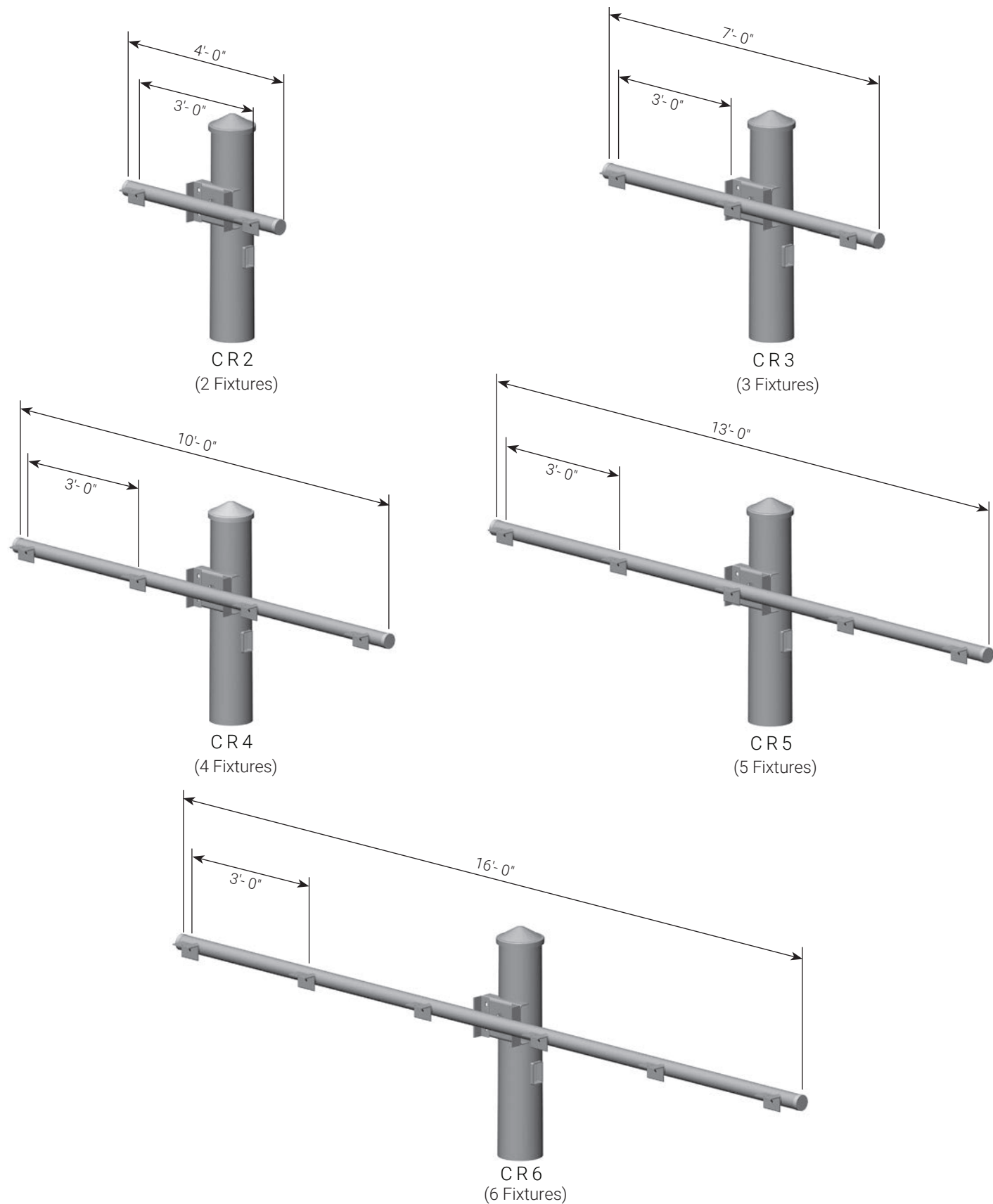

ANGLE IRON CROSS ARM DETAIL

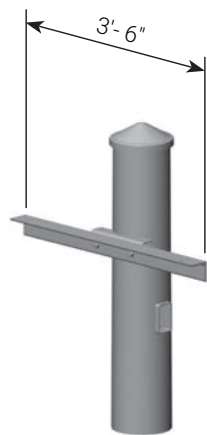

ACR2
(2 Fixtures)

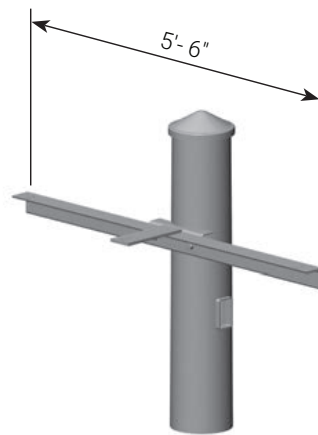

ACR3
(3 Fixtures)

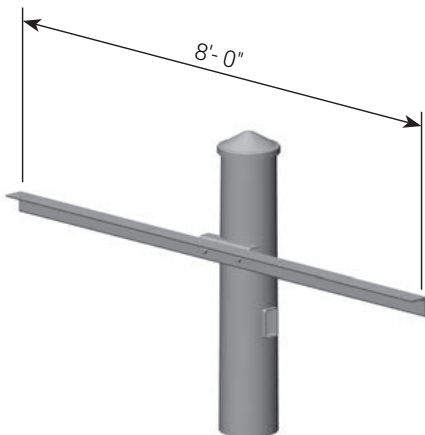

ACR4
(4 Fixtures)

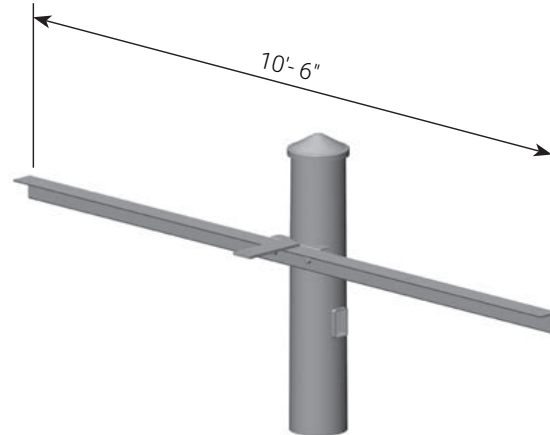

ACR5
(5 Fixtures)

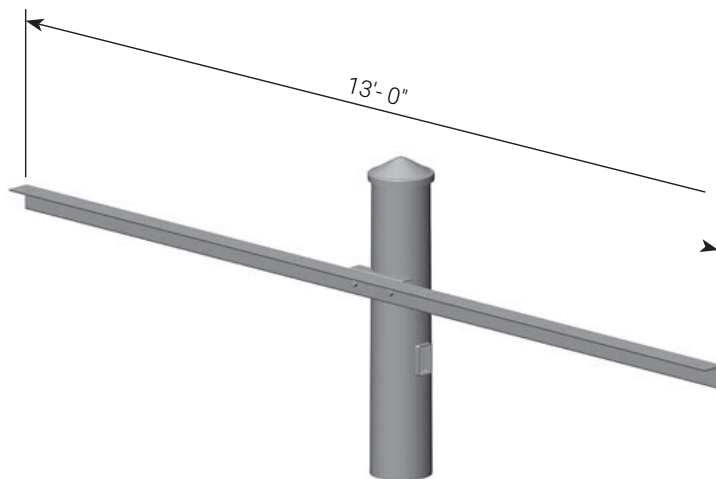

ACR6
(6 Fixtures)

Note: ACR2 Fixture Drillings Spaced 36" on Center
All Others: Fixture Drillings Spaced 30" on Center

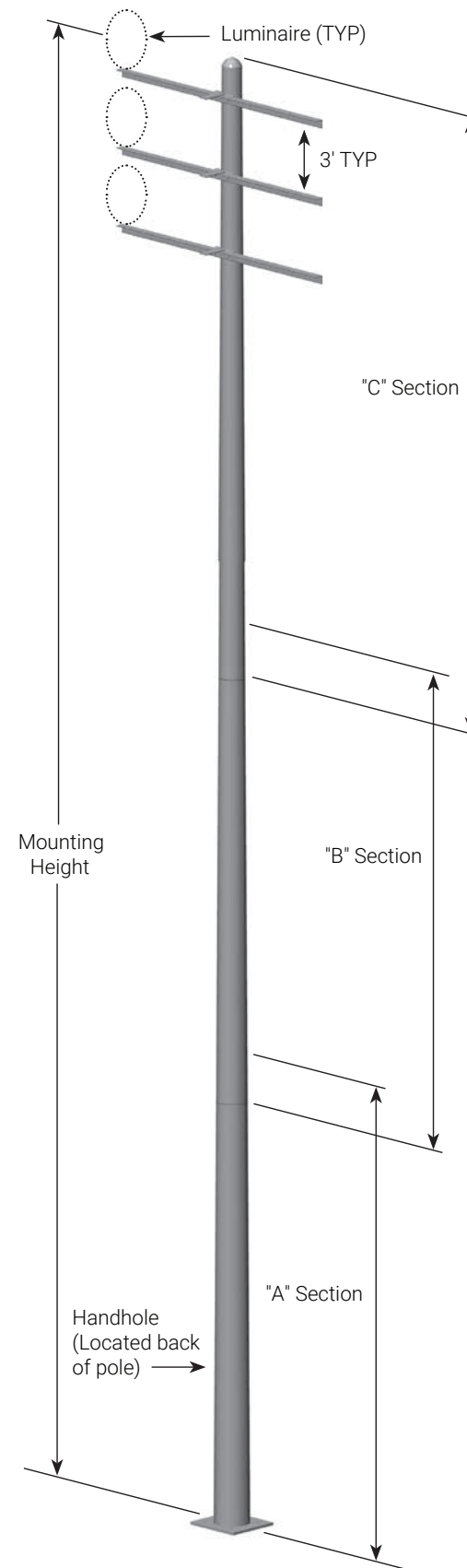

CROSSARM AND POLE

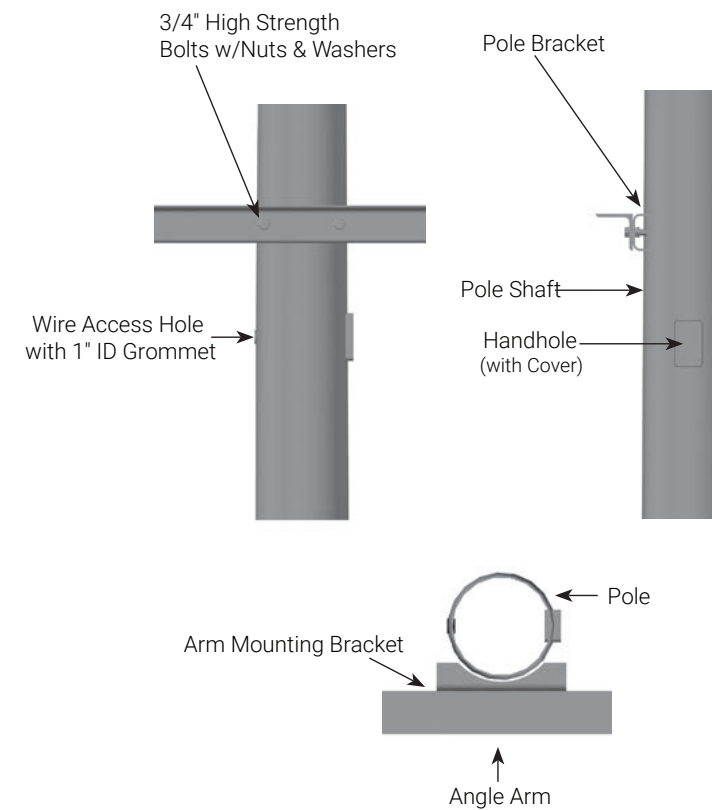

ACR MOUNTING DETAILS

BULLHORN BRACKET DETAIL

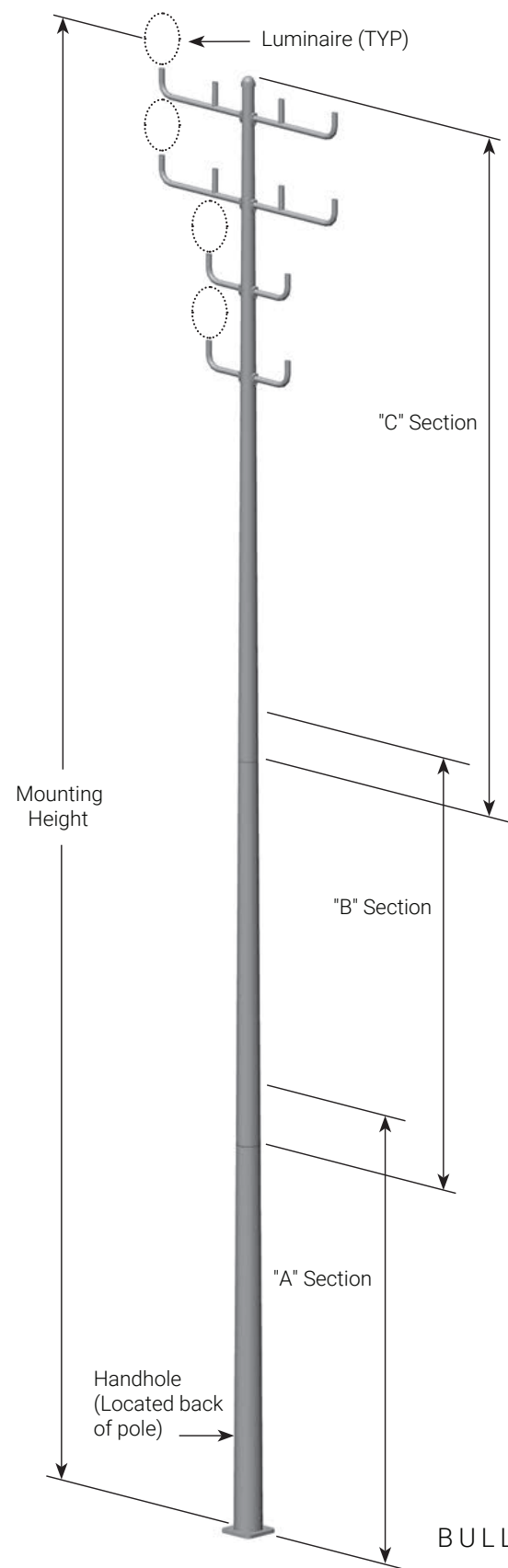

BULLHORNS AND POLE

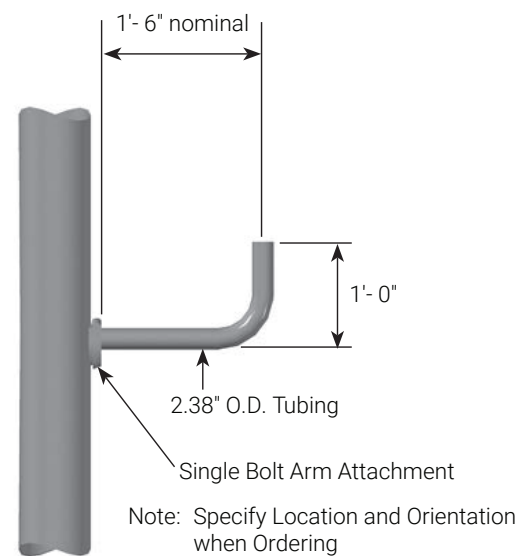

M080 ARM

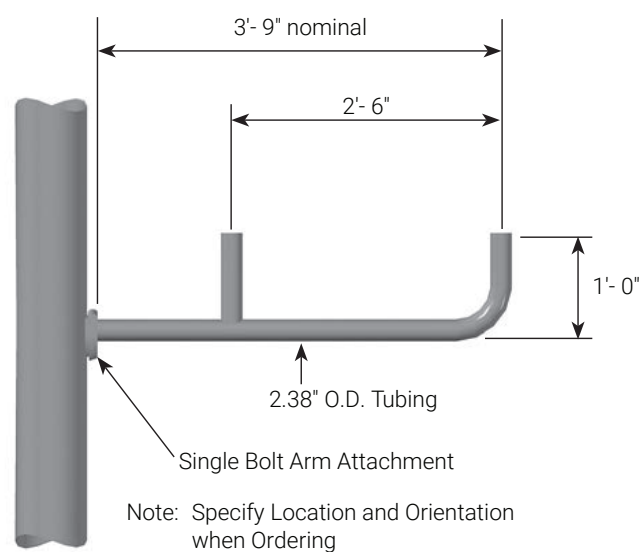

M082 ARM

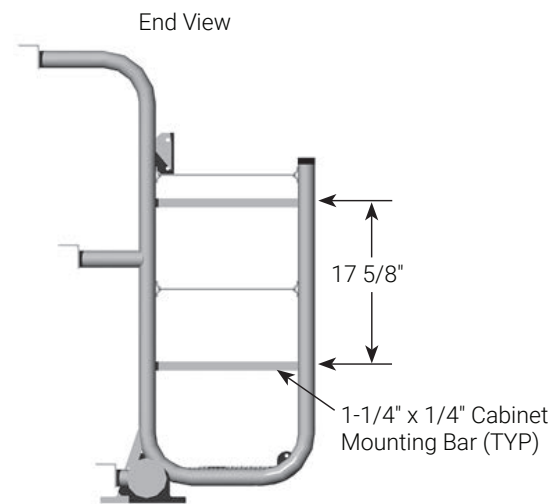

CONTROL PANEL - CAGE MOUNT

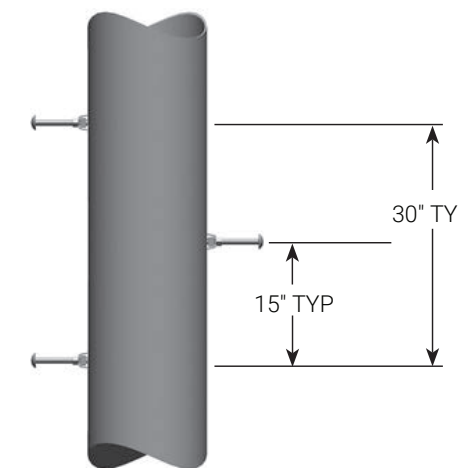
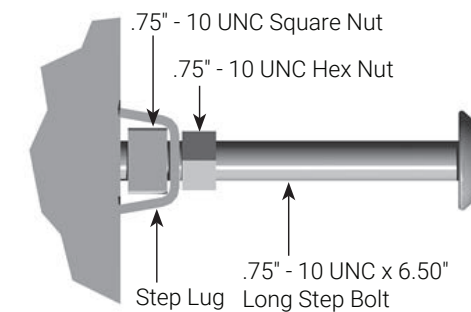

REMOVABLE POLE STEPS

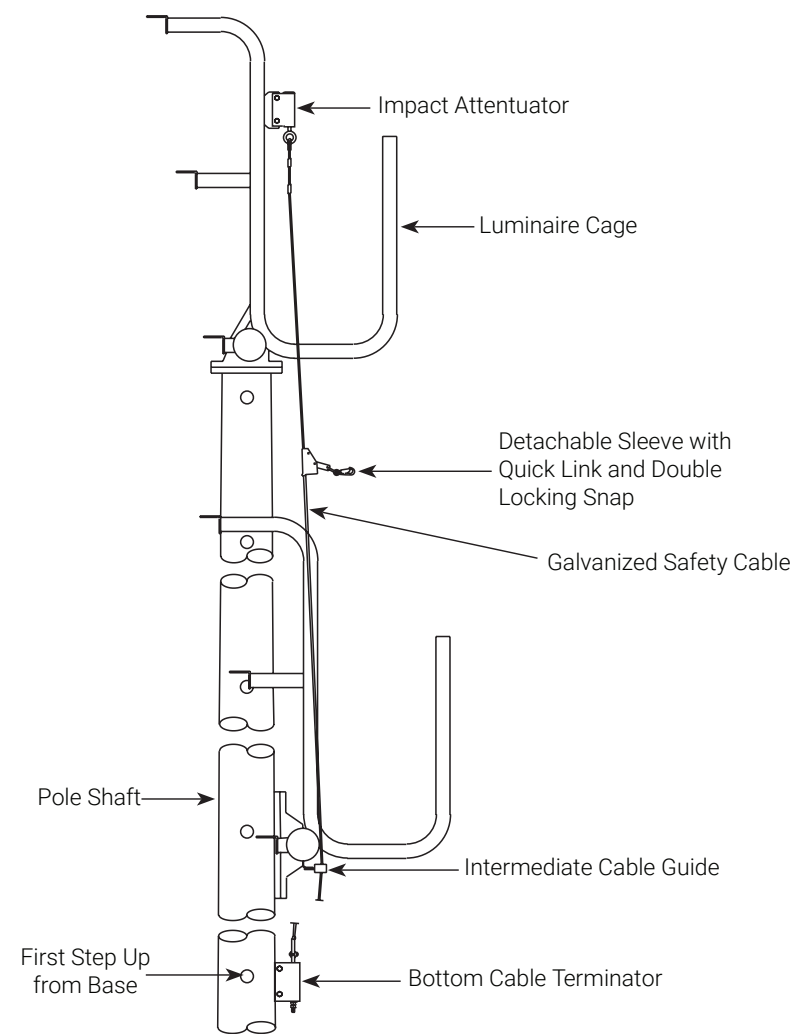

SAFETY CABLE CLIMBING DEVICE

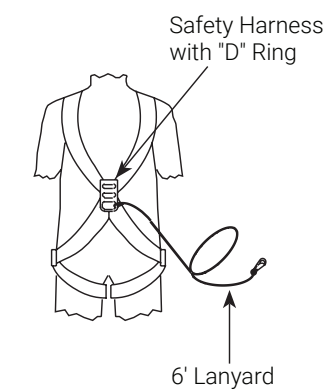

SAFETY HARNESS

SPORTS LIGHTING SPECIFICATIONS

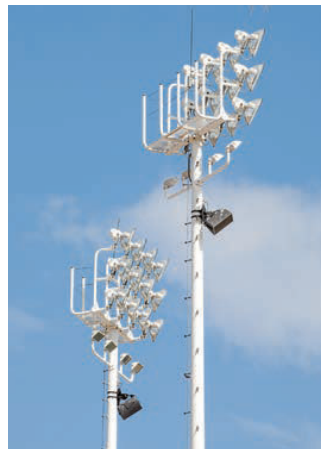

CAGED LUMINAIRE SERVICE PLATFORM

Platforms are made of tubular members to effectively reduce the wind drag. The cage consists of at least one horizontal steel supporting member, a minimum of 5½" O.D. 10-gauge material, and vertical luminaire supports of 2" schedule 40 pipe. All angles conform to ASTM designation A36. The vertical luminaire supports are available with horizontal angle luminaire support with holes to accommodate luminaire adapter plates or pipe tenons to accommodate specific size slipfitters. All pipe and tubing components are 36 KSI minimum yield strength.

The platform is a cage with vertical members, minimum 46" in height with two horizontal 3/16" diameter, 7 x 19 galvanized aircraft cables for enclosure and safety support of maintenance person. The floor is expanded metal grating. The floor incorporates a hinged door allowing for access to the cage and is capable of closing prior to uncoupling of climbing safety device.

The entire basket is capable of internal wiring from the pole shaft to the luminaire mounting supports. The pole top mounting bracket has internal drip shielding for wire entrance.

CROSSARM FOR LUMINAIRES

The crossarms are made of tubular members to effectively reduce wind drag. The crossarm consists of horizontal main members of 3½" O.D. schedule 40 pipe. All angles conform to ASTM designation A36. Horizontal, angle luminaire supports have holes to accommodate luminaire adaptor plates or pipe tenons to accommodate specific size slipfitters. Luminaire mounting angle supports are attached to the main member of 2" schedule 40 pipe. All pipe members and tubing components are 36 KSI minimum yield strength.

The crossarm is bolted to the pole shaft with 2½" x 2½" x ¼" angles. Wire entrance to the pole shaft is (a) standard 1" ID grommeted hole with 3" x 5" handhole, or (b) coupling (specify size) with a 3" x 5" handhole.

POLE SHAFTS

The cross-section is round or 16-sided with a 4" bend radius. Each pole is a constant tapered hollow steel section and is up to 55' in length with a 1½ times diameter slip joint as standard. The pole shaft sections are high strength steel to ASTM A572, ASTM A595, or weathering steel to ASTM A871 or ASTM A595 GR.C. The plate has a single thickness – no laminations.

BASE PLATE

The shaft is supplied with an integrally welded steel base plate. The base plate telescopes the pole shaft and is circumferentially welded top and bottom or has a full penetration butt weld with backing.

ANCHOR BOLTS

Anchor bolts are provided loose with a checking template as standard. Anchor bolts are galvanized to ASTM A153 for a minimum of 8" on the threaded end. If requested, bolts are shipped in rigid cages at extra cost. Each anchor bolt is supplied with one leveling nut, one hold down nut and two flat washers with strength equal to or exceeding the proof load of the bolt.

LOADING

Vertical forces due to pole weight, luminaires, attachments and maintenance device are included in the maximum stress at the base. Wind pressures, adjusted for shape and height, are applied to the centroids of all projected areas. Eccentric moments due to deflection under maximum wind and eccentric loads are considered.

PRE-WIRING

Cages and tubular crossarms are available from the factory pre-wired. Consult with your factory sales representative for more information.

WELDING

All welds are made using welders and procedures qualified in accordance with either the American Welding Society D1.1 Structural Steel Welding Code or the Canadian Welding Bureau as applicable. Additionally, weld inspections are performed in accordance with AWS D1.1.

FINISH

The finish is primed, painted, galvanized, or weathering steel. Prime painted is either spray or flow painted inside and out. Galvanizing on shafts meet all the requirements of ASTM A123, miscellaneous hardware is galvanized to ASTM A153. Galvanizing is done with a maximum pole section length of 55'. Weathering steel is shot blasted to clean the surface of foreign matter and ensure even oxidizing.

TESTING

A full scale vertical test facility is available at the factory to simulate actual full structure loads. Any test required is at customer's expense. Poles can be tested simulating maximum moment due to wind and eccentric forces (loads applied at four points) including, simultaneously, vertical forces.

VIBRATION DISCLAIMER

Although rare, vibrations severe enough to cause damage can occasionally occur in structures of all types. Because they are influenced by many interacting variables, vibrations are generally unpredictable. The user's maintenance program includes observation for excessive vibration and examination for any structural damage or bolt loosening. The factory warranty specifically excludes fatigue failure or similar phenomena resulting from induced vibration, harmonic oscillation or resonance associated with movement of air currents around the product.

SHIPPING

Pole structures are shipped by rail or truck at the option of the factory. All structures are firmly secured and adequately packed to assure protection to the structures and to finish.

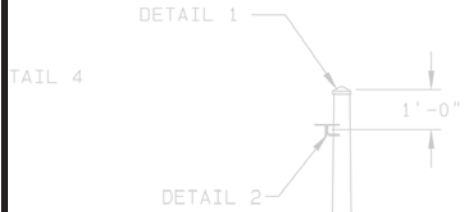

SECTION B



SECTION B



WILLTM | WISCONSIN LIGHTING LAB



SECTION A

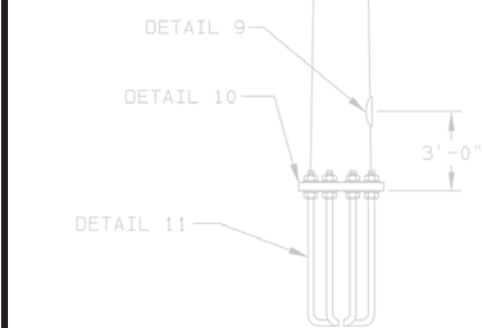

ITEM 1

866.308.9455
quotes@willbrands.com



SECTION A

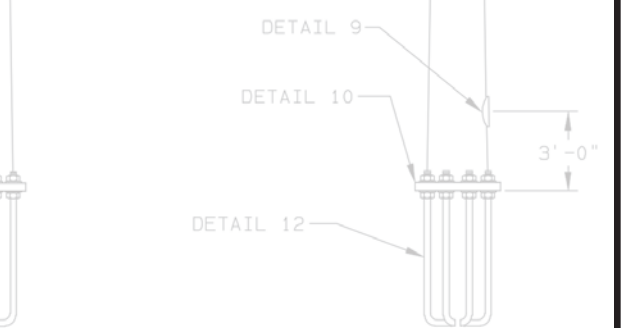

ITEM 2

SOLD TO: